

Artec 526

TWO-WAY VENTED LOUDSPEAKER SYSTEM



- >> Two-way vented loudspeaker system
- >> 2 x 6" cone speaker
- >> 1" exit compression driver with constant directivity horn
- >> 400 W power handling

The D.A.S. Artec 526 is a Two-way vented loudspeaker system designed for applications covering speech reinforcement and program reproduction.

The low end utilizes two high efficiency 6" low frequency speakers with 2" voice coil.

The high end makes use of a 1" exit compression driver with 1.75" titanium diaphragm, coupled to a 80° x 80° horn.

The unit has a robust grille design internally lined with acoustically transparent filter cloth to protect the loudspeaker components. The covering is resistant to wear and tear, provides protection from dust and dirt.

4 integrated rigging points that accept 10M forged steel eyebolts or "U" bracket make suspension in either the horizontal or vertical positions safe and simple.

Technical Specifications

RMS (Average) Power Handling ^R	400 W
Program Power Handling ^P	800 W
Peak Power Handling ^K	1600 W
On-axis Frequency Range	60 Hz - 20 kHz
Nominal Impedance	16 Ohms
Minimum Impedance	LF, 13.4 Ohms @ 200 kHz
On-axis Sensitivity 1W/1m	93 dB SPL
Rated Peak SPL at Full Power	125 dB SPL
Nominal -6dB Beamwidths	80° Horizontal x 80° Vertical
Enclosure Material	Wisa® Birch Plywood
Finish	Isoflex Black Paint
Transducers/Replacement Parts	LF: 2 x 6P / 6P HF: M34 / GM-M-34
Connector	2 paralleled NL4 Speakon, wired to +/-1
Dimensions (H x W x D)	54.5 x 19.4 x 25.5 cm 21.3 x 7.7 x 10 in
Weight	9 kg
Accessories (optional)	ANL-2 TRD-6 + AXC-ZT TRD-2 + AXC-ZT AXU-A526 AXW-1 AXR-A500

Dimensions

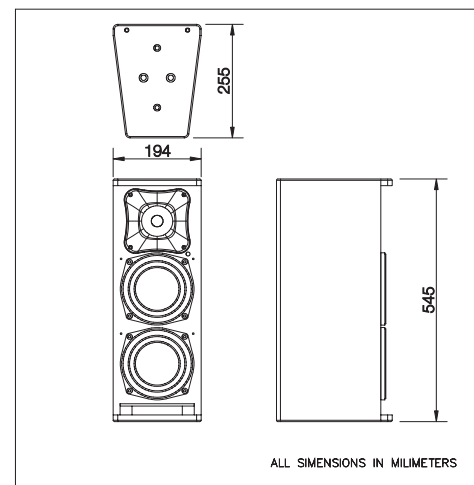

^R Based on a 2 hour test using a 6dB crest factor pink noise signal
^P Conventionally, 3dB higher than the RMS measure
^K Corresponds to the signal crests for the test described in ^R

Frequency Response

Shows the frequency response at 1m of a unit radiating to an anechoic environment (4π) and driven by a 1w (4 V) swept sine signal, and impedance curve. For better detail, only light smoothing (1/12th octave) has been used.

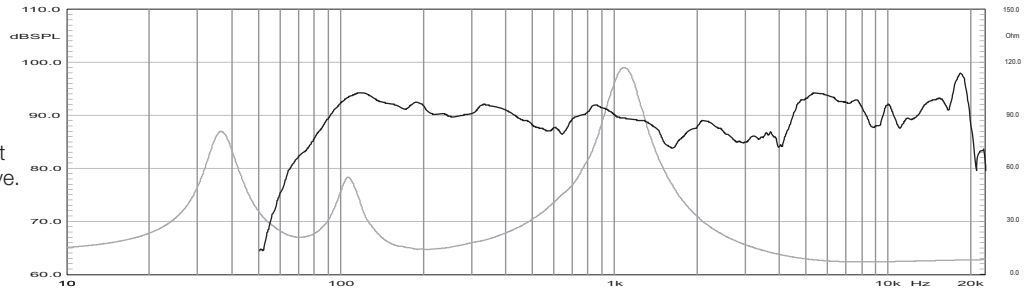

Distortion

Shows the Second Harmonic Distortion (grey) and Third Harmonic Distortion (dotted) curves for a unit driven at 10% of its nominal power rating. Raised 20dB for clarity.

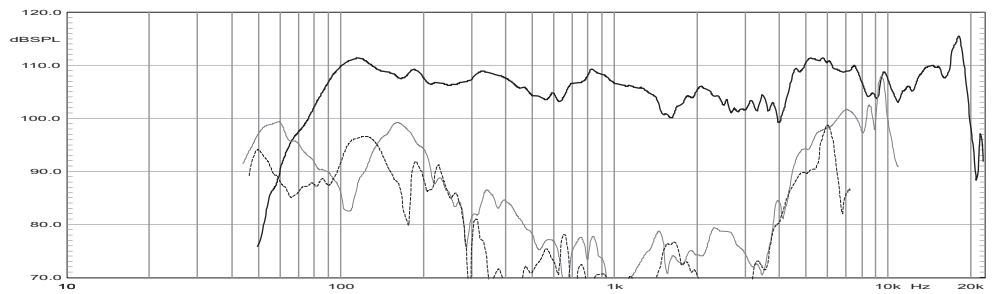

Directivity

Shows normalized horizontal isobar plot

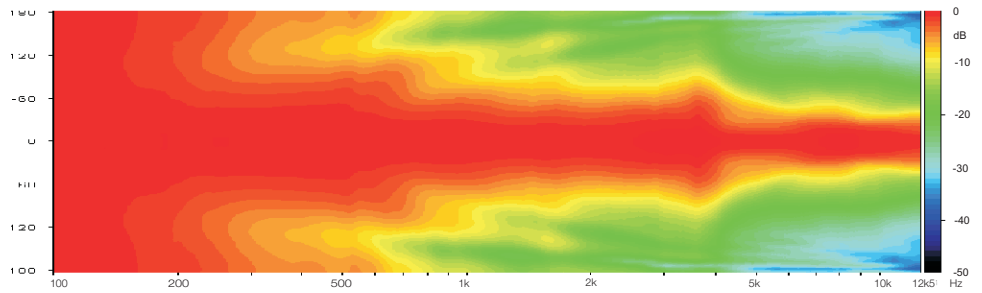

Directivity

Shows normalized vertical isobar plot

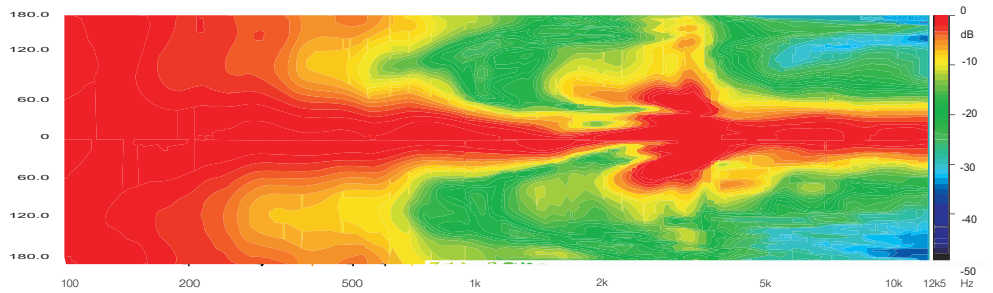

Polar Response

1/3 octave band horizontal (left) and vertical (right) polars for the indicated frequencies. Full scale is 30dB, 6dB per division.

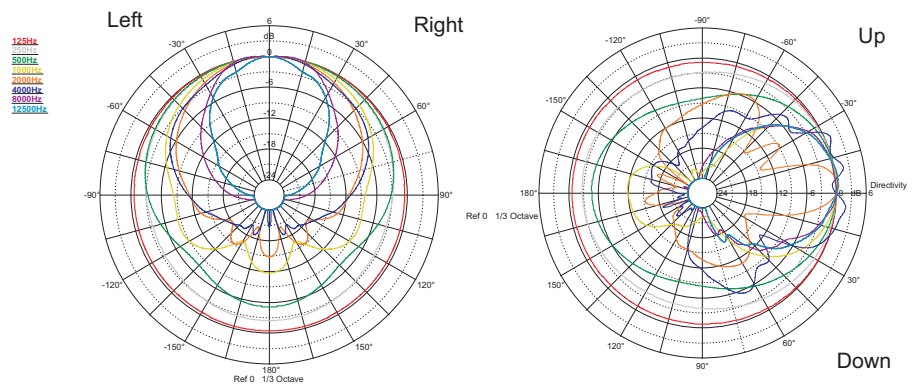

NOTES: Frequency response measured at 4m (13.12ft). For better detail, only light smoothing (1/12th octave) has been used. Polars were acquired by placing the unit on a computer controlled turntable inside a 300 m³ (10594 ft³) anechoic chamber. Measurement distance is 4m (13.12ft).

Product improvement through research and development is a continuous process at D.A.S. Audio. All specifications subject to change without notice.



D.A.S. Audio S.A.
 C/ Islas Baleares, 24
 46988 Fuente del Jarro
 Valencia - SPAIN
 Tel. 961 340 525 - Tel. Intl. +34 961 340 860
 Fax 961 340 607 - Fax Intl. +34 961 340 607

D.A.S. Audio of America Inc.
 Sunset Palmetto Park - 6816 NW 77th Court
 Miami, FL. 33166 U.S.A.
 Tel. 305 436 0521 - Fax. 305 436 0528
 Toll Free: 1 888 DAS 4 USA

D.A.S. Audio Asia Pte. Ltd.
 25 Kaki Bukit Crescent # 01-00/ 02-00
 Kaki Bukit Techpark I - Singapore 416256
 Co. Reg. No. 200704134E
 Tel. +65 6742 0151 - Fax. +65 6742 0157

www.dasaudio.com