

# Audio Presenter HUB

Audio and Presentation System

USER MANUAL

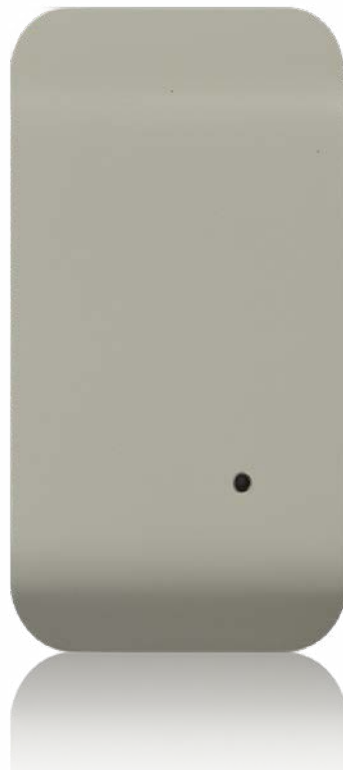

## Table of Contents

---

Safety Warnings and Instructions .....	6
Maintenance and Recycling Instructions .....	7
Overview .....	8
Introduction .....	8
This Manual.....	8
Presentation System.....	8
Save, Print, and Share Images.....	8
Annotation.....	8
Audio.....	10
HD Bluetooth .....	10
Features.....	10
General Installation .....	11
Controller.....	11
Bluetooth Wireless Access Point (B-WAP).....	11
Connecting the Video Source and Outputs .....	12
Connecting Devices .....	12
Power On .....	13
Audio Connections.....	14
Line Level Source (Phoenix style connectors).....	14
Connecting Speakers.....	15
Bluetooth Audio .....	15
Dante Devices.....	15
Controllers/Markers Overview.....	16
Remote Controllers .....	17
App for Phones and Tablets.....	17
From Your Browser .....	18
Toolbar.....	18
Clear All Marking.....	18
Erase Tool .....	18
Drawing Tools .....	18
Line Size.....	18
Line Color .....	18
White Board.....	19
HDMI.....	19
USB Camera.....	19
Streaming Input .....	19
Previous Slide.....	19

Next Slide .....	19
Record .....	19
Menu System .....	19
Overview .....	19
Using the Menu System .....	20
Menu Basics .....	20
Menu Conventions.....	20
Making menu selections.....	21
Setting Default User Settings.....	21
System Information .....	21
System Info .....	21
Scheduling Restarts .....	22
Detecting and Assigning Devices.....	22
Serial Port Settings.....	22
Manual Serial Port Assignment.....	23
Viewing a USB Device Type .....	24
Manually Assigning a USB Device.....	26
Integrating the Audio Presenter HUB with Other Systems.....	26
Setting COMM Port Parameters.....	27
Preparing Video Sources and Outputs .....	27
Setting Video Output.....	27
EDID .....	28
Video Source Options.....	28
Default Video Source.....	29
Picture-In-Picture (PIP) Setup .....	29
Networking (TCP/IP, TFTP, SMB) .....	30
Network Setup.....	30
Configure TFTP Settings .....	31
Configure Windows Share (SMB) Settings .....	32
Security PIN .....	33
Bluetooth Features .....	33
Connecting your Personal Device .....	34
Disconnecting your Personal Device.....	34
Streaming Content .....	34
Airplay from IOS Devices .....	34
Miracast Stream from Android devices (if available).....	34
Miracast Stream from a PC (if available).....	35
Using Chromecast from a Google Chrome Web Browser:.....	35
Streaming to Meeting Software or Screen Sharing Tools .....	35

---

Calibrating and Configuring Touch Screens .....	36
Calibrating Touch Screen Controllers .....	36
Touch Screen Command Areas .....	40
Customizing Markers and Pointers .....	41
Customizing the Color Palette.....	41
Selecting Colors for a Presentation.....	41
Selecting a Brightness Level .....	42
Zap Icon Toggle.....	43
Using Markers.....	43
Overview .....	43
Assigning Marker Colors .....	43
Entering the Marking Mode.....	45
Drawing.....	45
Selecting Pointers.....	45
Creating a Pointer.....	46
Turning the Active Pointer On/Off.....	46
Typing Text Labels .....	47
Displaying the Date/Time .....	47
Clearing All Markers.....	47
Undoing a Marker.....	48
Erasing Markers .....	48
Using The Chalkboard.....	49
Saving and Storing Images.....	49
Overview .....	49
Capture Options.....	50
Freezing Video.....	51
Setting the Destination for Saved Files.....	51
Setting the Verify Option.....	51
Saving Images .....	51
Retrieving Images.....	52
Printing Images.....	53
Printer Setup .....	53
Print an image.....	54
Verifying Saved or Printed Images.....	54
Updating the Audio Presenter HUB.....	54
Adjusting Settings from the Browser.....	55
Streaming Menu.....	55
Audio Menu .....	56
Network Settings .....	57

Printer Settings .....	57
Image File.....	58
Video Menu .....	58
System Settings.....	59
Connecting Personal Devices .....	59
Glossary .....	59
Troubleshooting Guide.....	62
Appendix .....	63
Quick Reference for Keyboard.....	63
Quick Reference for Touch Screens and Whiteboards.....	65
Symbol Font Chart.....	66
Map Font Chart.....	67
RS-232 (COMM Port) Pinout and Commands.....	68
Outside copyright information for software included with the Audio Presenter HUB .....	68
Specifications.....	74
Regulatory Statements.....	74
United States - FCC .....	74
Canada IC.....	74
Japanese Regulatory Standards .....	74
Limited Warranty .....	75

## Safety Warnings and Instructions

---

**WARNING!** TO REDUCE THE RISK OF FIRE OR ELECTRIC SHOCK, DO NOT EXPOSE THIS APPLIANCE TO RAIN OR MOISTURE.

**CAUTION!** TO REDUCE THE RISK OF ELECTRIC SHOCK, DO NOT REMOVE COVER. NO USER-SERVICEABLE PARTS INSIDE. REFER SERVICING TO QUALIFIED SERVICE PERSONNEL.

**POWER CORD NOTICE FOR INTERNATIONAL OPERATION** - Please call Williams AV Customer Service at 800.328.6190 to order the appropriate power cord for the country of use.

**Important Safety Instructions:**

1. Read these instructions
2. Keep these instructions
3. Heed all warnings
4. Follow all instructions
5. Do not use this apparatus near water.
6. Clean only with dry cloth.
7. Do not block any ventilation openings. Install in accordance with the manufacturer's instructions.
8. Do not install near any heat sources such as radiators, heat registers, stoves, or other apparatus (including amplifiers) that produce heat.
9. Do not defeat the safety purpose of the polarized or grounding-type plug. A polarized plug has two blades with one wider than the other. A grounding type plug has two blades and a third grounding prong. The wide blade or the third prong is provided for your safety. If the provided plug does not fit into your outlet, consult an electrician for replacement of the obsolete outlet.
10. Protect the power cord from being walked on or pinched particularly at plugs, convenience receptacles, and the point where they exit from the apparatus.
11. Only use attachments/accessories specified by the manufacturer.
12. Unplug this apparatus during lightning storms or when unused for long periods of time.
13. Refer all servicing to qualified service personnel.
14. The apparatus shall not be exposed to liquids.
15. Carts and Stands - The appliance should be used only with a cart or stand that is recommended by the manufacturer. An appliance and cart combination should be moved with care. Quick stops, excessive force and uneven surfaces may cause the appliance and cart combination to overturn.
16. Power Sources - The appliance should be connected to a power supply only of the type described in the operating instructions or as marked on the appliance.
17. Object and Liquid Entry - Care should be taken so that objects do not fall and liquids are not spilled into the enclosure through the openings.
18. Servicing - The user should not attempt to service the appliance beyond that described in the operating instructions. All other servicing should be referred to qualified service personnel.

**Precautions:**

1. Power – WARNING, BEFORE TURNING ON THE POWER FOR THE FIRST TIME, READ THE FOLLOWING SECTION CAREFULLY. The unit is designed for use only with the line cord of the region in which it will be operated.
2. Voltage Label (Rear Panel) – A label located at the rear panel power connection indicates the DC power input for the unit. The label will read 24VDC. Note: use the Williams AV TFP 059 power supply for this unit.
3. Do Not Plug in the HDMI input, output, Comm 1, Comm 2, Ethernet, or USB connections while the power switch is switched to the ON position.
4. Do Not Touch any part of the Audio Presenter HUB with wet hands. Do not handle any part of system, including the power cord, when your hands are wet or damp. If water or any other liquid enters the Audio Presenter HUB or Audio Presenter HUB 's location, take the device to qualified service personnel for inspection.
5. Place all components of the Audio Presenter HUB in a well ventilated location. Take special care to provide plenty of ventilation on all sides of the system components, especially when it is placed in a small location, such as a rack. If ventilation is blocked, the system may over heat and malfunction.
6. Do not expose the Audio Presenter HUB to direct sun light or heating units as the system's internal components temperature may rise and shorten the life of the components. Avoid damp and dusty places.
7. Care – From time to time you should wipe off the front and side panels and the cabinet with a soft cloth. Do not use rough material, thinners, alcohol or other chemical solvents or cloths since this may damage the finish or remove the panel graphics.

## Maintenance and Recycling Instructions

---



Help Williams AV protect the environment. Please take the time to dispose of your equipment properly.

**Product Recycling:**

Please do NOT dispose of your equipment in the household trash. Take the equipment to a electronics recycling center.

### **Servicing or attempting to service this device will void the warranty**

Refer servicing to qualified personnel. Servicing is required when the system has been damaged in any way: if liquid has been spilled or objects have fallen into the unit, if the unit has been exposed to moisture, if the unit does not operate normally, or if the unit has been dropped.

Do not block any ventilation openings. Install in accordance with manufacturer's instructions.

Do not install near any heat sources such as radiators, heat registers, stoves, or other apparatus that produces heat.

Use only attachments/accessories specified by the manufacturer.

Unplug the transmitter during lightning storms or when unused for long periods of time.

Be advised that different operating voltages require the use of different types of line cord and attachment plugs. Check the voltage in your area and use the correct type.

Use only the power supply provided by Williams AV. Other power supplies may have similar specifications, but may not be equivalent in emissions ratings, in-rush current, etc. Use of an unapproved power supply may leave the device partially or completely inoperable, and will void the warranty.

This apparatus has been designed with class-1 construction and must be connected to a main socket outlet with a protective ground connection (the third grounding prong).

Protect the power cord from being walked on or pinched, particularly at plugs, receptacles, and near the power jack on the transmitter.

The MAINS plug or an appliance coupler is used as the disconnect device, so the disconnect device should remain readily operable.

---

# Overview

---

## Introduction

The Audio Presenter HUB (VP S2) is a professional, hardware-based video processor, designed so that users can display and share content from an smartphone or tablet, as well as from multiple video and computer sources connected directly to the Audio Presenter HUB. This model also has the ability to change settings, switch video sources, and annotate from remote computers, tablets, and smartphones.

## This Manual

This manual provides instructions for configuring your Audio Presenter HUB, using the built in system menu, creating annotations, providing video sources, and connecting and using physical controllers (such as a keyboard or mouse).

For instructions on using Remote Controllers, such as a smartphone or a web browser, please see the **Remote Controllers** section.

For instructions on configuring RS-232 devices to send commands to the Audio Presenter HUB, follow the instructions in this manual for proper wiring and configuration. Once your RS-232 device is properly wired, please see the **RS-232 (COMM Port) Pinout and Commands** section, and reference the Programmer's Guide. The Programmer's Guide has a list of detailed commands that can be sent to the Audio Presenter HUB.

## Presentation System

No matter where your presentation is stored, it is easy to share your presentation with the group.

Whether your presentation is stored on a PC or Mac, Android tablet or phone, iPad or iPhone, you can wirelessly stream the content to the Audio Presenter HUB using Miracast, Airplay, or Googlecast.

**Note:** Miracast is not available in all countries. Please check with your local Distributor.

You can also use an HDMI cable to manually connect to the Audio Presenter HUB. There is even a USB video input for a document camera.

The Audio Presenter HUB offers many control options to create powerful presentations. Control options include an Apple app, an Android app, a browser interface, and a touch screen GUI from the Audio Presenter HUB itself. It is also possible to control Audio Presenter HUB with Crestron, or AMX type room control system. All of the Audio Presenter HUB user interfaces have the same look and feel. Whether you are using your PC, iPhone or other device, using the Audio Presenter HUB is intuitive and familiar. Choose whatever works best for you.

## Save, Print, and Share Images

The Audio Presenter HUB gives the user the ability to save, print, and share annotated images. An annotated image can be saved to a USB storage device, such as a flash drive. Users can also print annotated images to a printer. Images can be shared over a TCP/IP network through Windows Share.

## Annotation

The user has a variety of options for drawing lines and markers during a presentation. The Audio Presenter HUB is compatible with most touch screens, keyboards and mouse devices. An smartphone or tablet can also be used for annotation.



	B	C	D	E	F	G	H	I	J	K	L
1	J	F	M	A	M	J	J	A	S	Total	Projected
2	8.25	26.50	78.75	36.50	23.25	19.75	32.25	0.50	0.00	221.75	544.00
3	29.50	16.00	0.50	27.25	33.25	21.25	0.00	44.75	0.00	172.50	332.00
4	26.75	55.00	12.75	19.50	0.00	2.00	0.50	26.50	0.00	140.00	212.00
5	19.50	8.00	11.00	19.75	26.50	22.75	3.00	20.25	0.00	130.75	303.00
6	2.25	0.50	4.50	1.00	0.50	9.00	4.50	0.00	0.00	22.25	40.00
7	17.50	14.00	2.00	25.00	18.25	10.50	2.50	13.00	0.00	104.25	260.00
8	7.00	0.75	3.00	0.00	23.75	4.75	2.50	5.75	0.00	73.00	62.00
9	0.00	0.00	0.00	0.00	0.00	0.00	0.00	0.00	0.00	1.50	40.00
10	1.00	0.00	2.50	3.00	7.75	5.50	13.00	7.50	0.00	38.25	86.00
11	5.00	10.75	2.75	19.50	13.25	2.50	11.50	4.25	0.00	59.50	80.00
12	33.00	15.75	28.75	14.50	13.75	19.50	56.75	36.00	0.00	218.00	351.00
13	0.00	1.00	0.00	3.25	0.00	11.00	27.25	4.00	0.00	56.50	1.00
14	0.00	0.00	0.00	0.00	0.00	0.00	0.00	2.50	0.00	2.50	1.00
15	1.75	4.50	0.75	4.50	0.75	12.50	1.50	2.75	0.00	29.00	15.00
16	12.00	0.00	3.50	3.00	3.75	3.00	2.50	2.00	0.00	29.75	14.00
17	163.50	157.75	151.50	174.00	163.75	155.50	157.75	175.75	0.00	1299.50	2341.00
18											

#### Marking example over an image of a spreadsheet

Video is annotated using several simple-to-use graphics called markers. There are two types of markers: pointers (such as an arrow) and freehand drawing. Pointers and drawings may be used in combination to annotate. Markers are easily erased either one at a time until the screen is clear, or all at once.

When a keyboard is attached, text, a date/time stamp, and straight line drawing are available. With the various marker selections available, users can choose the best option to increase contrast over the image or video displayed in the monitor.

Users may also display a white background on the screen and use it like a whiteboard on which to “draw out” your point.

## Audio

The unique difference between the Presenter HUB and the Audio Presenter HUB is the ability to integrate advanced sound systems. The Audio Presenter HUB can take input from a variety of audio setups and output to speaker systems. Several hookups are provided on the back of the device to take input from an already-existing audio setup. The Audio Presenter HUB can then add its video source and annotation abilities to create a fully integrated audio and video presentation.

## HD Bluetooth

An excellent Bluetooth connection is made possible with the **Bluetooth Wireless Access Point (B-WAP)**. The B-WAP is a separate device from the Audio Presenter HUB Controller and functions as a transceiver. The B-WAP is installed on the ceiling or convenient location in the conference room, just like any other wireless access point. The B-WAP broadcasts a strong Bluetooth signal where conference attendees are sitting, eliminating any signal interference between the conference area and the Audio Presenter HUB Controller. The B-WAP is connected to the Audio Presenter HUB Controller via a CAT5 or CAT6 cable.

Note: A CAT6 cable is recommended whenever possible.



Figure 3: The Bluetooth Wireless Access Point (B-WAP)

## Features

- Two marking tools.
  - 2 pointers with 8 arrows of various angles, plus 2 dots and 2 cross hairs in a small or large size.
  - Freehand draw in 7 solid line colors, 4 different line thicknesses (with or without drop shadows), plus 3 highlight colors.
- Four additional marking tools with keyboard connected.
  - Straight line drawing mode allows underscoring, mapping or otherwise drawing a straight line.
  - Text can be typed on the video image in one of 6 different fonts, each available in one or more sizes. A text background may be added to further highlight the text on the video image.
  - An active date/time label (sometimes called a date/time stamp) can be placed on the video image to time an event. This label is very useful for record keeping when saving or printing images because it is embedded in the image.
- The ability to position and anchor a combination of several markers and drawings on the screen at once.
- Easily save, print, and share annotated images.
- Options for clearing lines and pointers from an overlay all at once or one at a time, beginning with the most recently anchored marker.
- Ability to assign a unique marker color (up to 7) to each marking device and switch between colors during a presentation.
- 3 highlight colors can be used to create a see-through colored overlay, just like highlighters on paper.
- A drop shadow effect may be selected to further optimize the display of annotated lines over the background.

- Compatibility with HDMI equipment.
- A solid white chalkboard can be selected for drawing when the video image is no longer needed.
- Sync generation allows the Audio Presenter HUB to automatically select the sync if no live video is desired. In the event that sync from a poor video source is lost, the Audio Presenter HUB will automatically switch to chalkboard mode if auto-chalkboard is enabled.
- Keyboard control provides a quick way to select many of the Menu System options without having to go to the Menu System. Instead, function keys provide choices for pointer type, background, marker colors, brightness levels, video source selection, and more.
- Brightness adjustment gives you the opportunity to set the brightness of the markers to coincide with the brightness level of the video signal, so that the markers are displayed optimally for standard video or for professional broadcasting.
- AV programmable so that AV control systems can control the Audio Presenter HUB using programmable commands.
- Two RS-232 ports allow the simultaneous use of two RS-232 communications devices, such as tablets or touchscreens.
- Five USB 3.0 ports allow the simultaneous use USB tablets, USB touch screens, or other USB control devices. The use of USB hubs increases the device limit to more USB control devices.
- Options available to multiple users to designate which RS-232 tablet or touchscreen takes priority over the other when both are drawing.
- Advance or return to slides via Bluetooth connectivity.
- Record the entire presentation as an MP4 to archive or replay.
- Easily switch between content, sources, and presentation materials.
- Annotate regions of interest to focus your audience's attention.
- Display a whiteboard to further explain key or complex thoughts, then return to the presentation seamlessly.
- Shows 4K video, allowing for the most eye catching images and critical details to be clearly examined.

## General Installation

### Controller

The Controller is a rack unit to which speakers and other devices will be connected.

Most wired devices will connect via one of the ports on the back panel. There are numerous ports to connect to, including USB, HDMI, COMM ports and a Phoenix-Style connector.

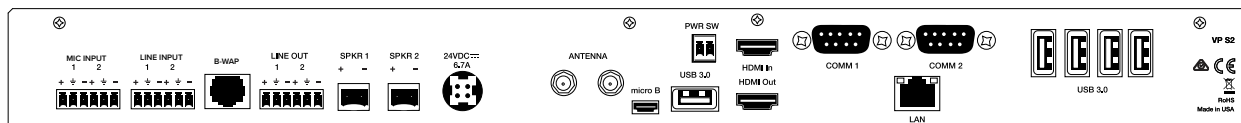

Back Panel Diagram

### Bluetooth Wireless Access Point (B-WAP)

Williams AV recommends that the B-WAP is installed on the ceiling near the center of the room, preferably above where the Audio Presenter HUB will be most frequently used. Other locations may work, such as on a wall. The B-WAP's Bluetooth signal has up to a 50 ft (15.24 m) radius, which should adequately provide coverage for most rooms.

 **Caution:** A 20 CM separation distance must be maintained between the Bluetooth Wireless Access Point's Bluetooth antenna and the user's body at all times. Do not install the B-WAP where this distance is not feasible.

The B-WAP will be connected to the Controller via a CAT6 cable. The maximum efficient length of the CAT6 cable is about 100 ft (31 m), and longer cables may cause a drop in signal or audio quality.

The CAT6 cable should be connected from the RJ45 port on the back of the B-WAP into the B-WAP port on the back of the Controller.

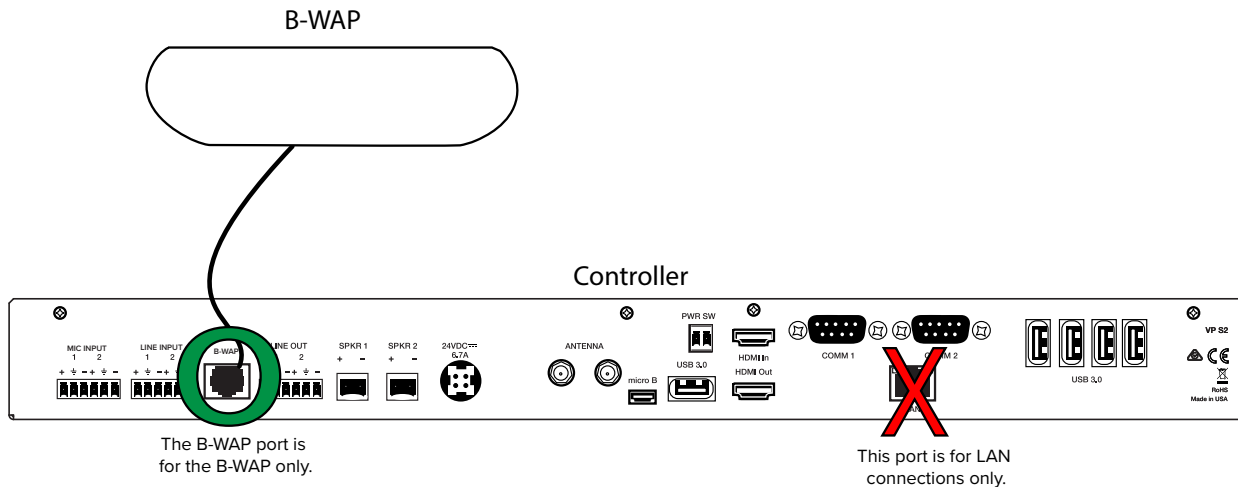

**The B-WAP connects to the Controller via the B-WAP port.**

**Note:** Do not connect the B-WAP to the LAN port on the Controller - only connect it to the B-WAP port.

The B-WAP is powered via the CAT 6 cable and requires no other connections.

## Connecting the Video Source and Outputs

### HDMI Connectors

To connect HDMI video:

**HDMI Input into Audio Presenter HUB:** Using HDMI video cable, connect the cable to the HDMI In port on the back panel of the Audio Presenter HUB.

**HDMI Output from Audio Presenter HUB:** Using HDMI video cable, connect the cable to the HDMI Out port on the back of the Audio Presenter HUB to HDMI In on a HDMI display.

## Connecting Devices

Here are some guidelines for setting up these devices.

**IMPORTANT:** Be sure to power down the Audio Presenter HUB before connecting or disconnecting any controllers. The Audio Presenter HUB will automatically detect installed controllers upon turning the power on. If you change controllers or add a new controller, you need to turn power off, install the new controller(s), then turn the power on.

### Connecting the Keyboard, Tablet or other USB Devices

Connect the device(s) to any USB port on the Audio Presenter HUB. The system supports up to 5 USB 3.0 devices and 1 USB B device.

## Connecting the Phoenix Connector

Connect the wires from your power controller (or other device) to the Audio Presenter HUB's Phoenix-style connector (labeled on the back of the device as PWR SW). When the relay is thrown, the Audio Presenter HUB will power on or off, as a toggle.

## Connecting Touch Screens and Electronic Whiteboards

The Audio Presenter HUB is compatible with many types of touch screens (call Williams AV for compatibility), and each device will have its own method of connection. Use the instructions for your touch screen or whiteboard for help connecting to the Audio Presenter HUB.

Audio Presenter HUB is compatible with HID devices.

## Connecting a 3rd Party Controller - COMM Port Wiring Issues

Customers sometimes encounter issues with the wiring of controllers. The following information may be helpful in resolving any issues.

- COMM ports sometimes use pin 9 to supply power to the RS-232 line drivers. Pin 9 was selected because its specification is seldom used. If you are connecting a device other than a line driver to a COMM port, the voltage may cause unexpected issues with the device.
- COMM 2 is set up as the default control port.
- COMM 1 and COMM 2 have jumpers for power on pin 9, and are set to OFF when shipped from the factory. If you require power from either or both of these COMM ports, please contact technical support.

## Connecting USB Devices

1. Make video connections as indicated earlier in this section, and install the touch screen to the monitor as directed by your touch screen manufacturer.
2. Connect a USB cable and extension to the USB port on the Audio Presenter HUB.

## Power On

To power on the Audio Presenter HUB:

1. Plug the power cord into the back of the Audio Presenter HUB and then into any grounded outlet.
2. Plug the power cords from any video source(s), controller(s), and display(s) into any grounded outlet.
3. Turn on each of the connected units, and then press the power button on the front panel of the Audio Presenter HUB.

**NOTE:** In order for the Audio Presenter HUB to properly sync with the video signals, the sources should be turned on first.

After a moment, a Audio Presenter HUB splash screen will appear, followed by the initializing of the ports, and ending with a copyright message.

After the startup process, the default input source will be shown.

If this process is different for you, recheck your installation and power on again. Call Williams AV for support if it is still unsuccessful.

**NOTE:** To bypass port initialization, press ESC during startup.

## Audio Connections

Audio is the Audio Presenter HUB's speciality. Audio may be provided by many sources, and outputted into many sources, including advanced sound systems.

### Line Level Source (Phoenix style connectors)

The Audio Presenter HUB will accept line level balanced or unbalanced audio inputs. Select the frequency you wish to transmit on and connect your audio source(s) to the appropriate Phoenix style connectors. No adjustment needs to be made for balanced or unbalanced inputs; this is internally detected & managed.

#### UNBALANCED AUDIO

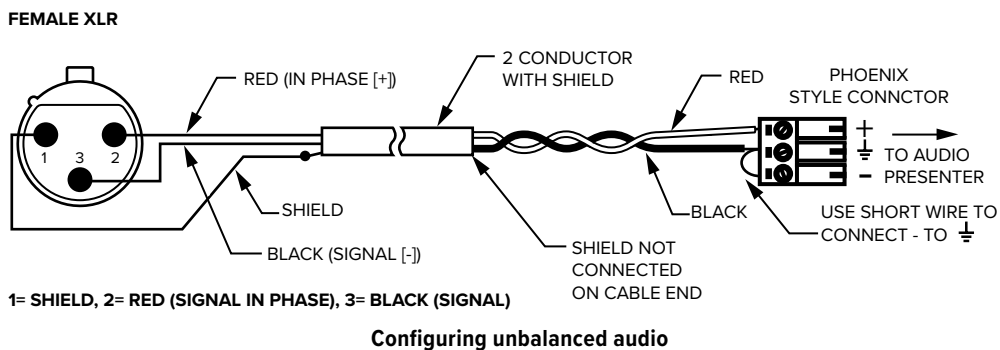

#### BALANCED AUDIO

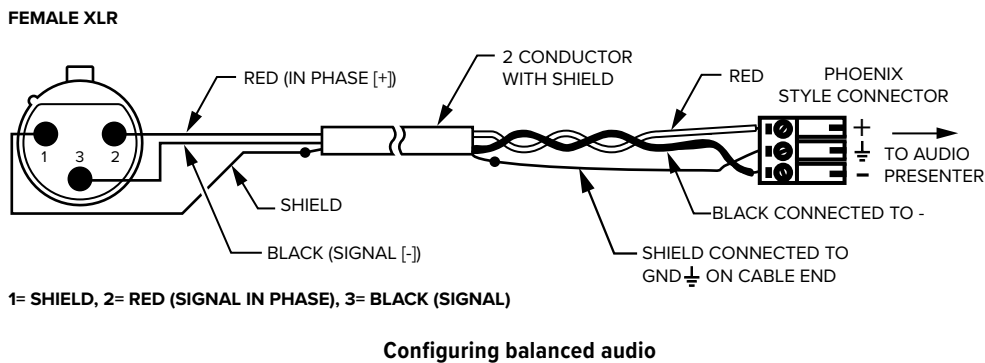

### Summing an unbalanced stereo line-level source to a single mono input

If using a stereo source for an input, the stereo signal will be combined to mono, and heard in mono.

The + and - phoenix terminals are *each tied internally to single differential amplifiers*.

**Proper Wiring:** The L+ cable can be connected directly to the + connector. The R + cables should not be used at all.

When summing for stereo to mono only, the resistors, along with the jumper between - and ground, are necessary to allow the left and right signals to be summed before being preamplified by the *single differential (single-ended) amplifier*.

**Improper Wiring:** If the left and right positive leads from the source were connected to the + and - pins on the Phoenix style connector, and their grounds (shields) were connected to the ground terminal, the result would be the *difference* of the left and right channels. The main part of the audio signal (what is common to both the left and right channels) would be missing, as this is thrown away during *differential amplification*. The difference is *very little*, resulting in a very low input signal. In this case, most of the original audio would not be heard!

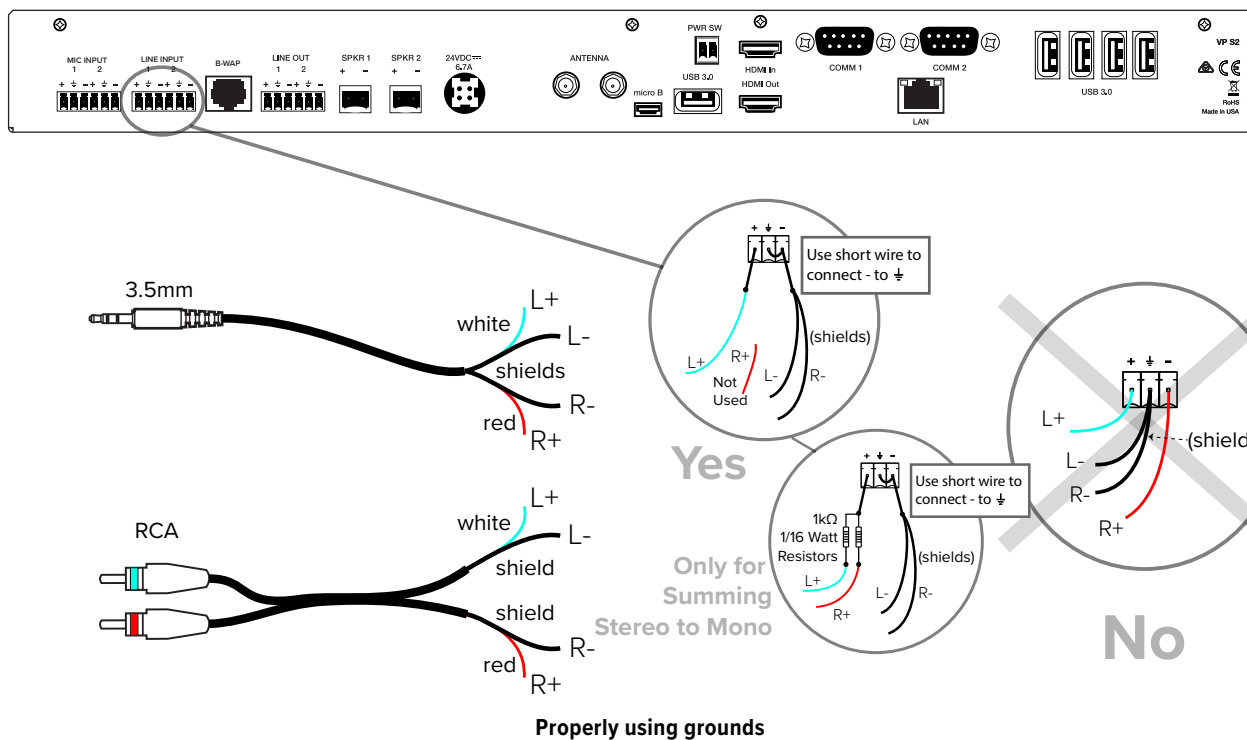

### Connecting Speakers

Speakers for audio output can be connected to the Audio Presenter HUB. Up to two speakers can be connected to the Audio Presenter HUB via the Speaker 1 and Speaker 2 port on the back of the device.

Bluetooth or Wi-Fi capable speakers can also be connected via the Audio Output menu. See the Audio Configuration section for more details.

### Bluetooth Audio

The Audio Presenter HUB can stream professional quality Bluetooth audio. For assistance setting up Bluetooth audio, see “Bluetooth Features” on page 33.

### Dante Devices

Dante devices are not directly compatible with the Audio Presenter HUB; however, a Dante mixer can be attached to the Audio Presenter HUB’s Controller, with any other Dante devices connected to the mixer. The Audio Presenter HUB system will then treat the mixer like any other audio source.

---

## Controllers/Markers Overview

---

The following categories of controllers can be used with the Audio Presenter HUB via cables:

- Touch Screens
- Electronic Whiteboards
- Keyboard
- Mouse devices

The Audio Presenter HUB can be controlled remotely through computers, tablets, or smartphones. See **Remote Controllers** for more information.

The Audio Presenter HUB can support most of the common devices you might use. The Audio Presenter HUB supports up to two RS-232 devices and up to 5 USB devices,. With the addition of a powered USB hub, more devices can be used.

### Keyboard

With a keyboard, you can select, type, position, save, and erase the markers on the overlay. You also use the keyboard to access the menu system and change the appearance of markers. More details on each key's functions can be found in the Appendix under Quick Reference for Keyboard.

#### Keyboard Controller Functions

The keyboard functions can display markers or affect their appearance. The keyboard can also control operations of the unit, such as changing to a different marker overlay or switching to a different video source.

#### Marker and Cursor Movement

When operating the Audio Presenter HUB with the keyboard controller, you can position active markers using the arrow keys. For fine movement, press the CTRL key along with one of the arrow keys.

Within menus, you can move cursors among the options by using the arrow keys.

### Touch Screens and Whiteboards

The Audio Presenter HUB is engineered for use with many touch screens or interactive whiteboards sold by other manufacturers. Contact Williams AV for compatibility information.

In general, you use the touch screen to draw, position arrows and pointers, or make menu selections.

Calibrating the touch screen enhances the intuitive feel of drawing on the display. It's essential to do a calibration the first time you start the unit after connecting the touch screen for accurate control.

#### Function Areas

Function areas are the eight regions on the touch screen that activate a function when tapped. Function areas can be found in the upper center, upper right, center right, lower right, lower center, lower left, center left, and upper left of the touch screen.

Upon initial set-up, the Menu can be accessed from the upper center touch screen function area. Once initial set-up is completed, a user can assign desired functions to the touch screen areas.

If you are drawing and move across one of these areas, the function is not activated. Only tapping will trigger the function area.

Details on touch screen functions can be found in the Appendix under Quick Reference for Touch Screens and Whiteboard.



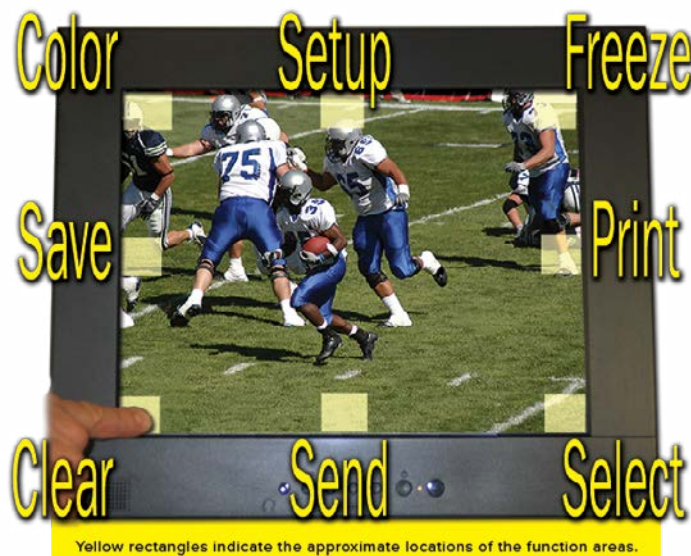

### Touch Screen Function Areas

#### Marker and Cursor Movement

When operating the Audio Presenter HUB with a touch screen, you position arrows or pointers anytime you tap the screen. You cannot reposition an anchored arrow or pointer; however, you can clear or erase a pointer and begin again.

#### Mouse Devices

The Audio Presenter HUB can also be used with a variety of PC-compatible mouse with two buttons.

##### Left Button

The Left Button on a mouse allows you to draw when pressed, or anchor an arrow or pointer when clicked.

##### Right Button

The Right Button on a mouse allows you to undo or clear a marker.

#### Marker and Cursor Movement

When operating the Audio Presenter HUB with a mouse, you can move the cursor or active pointer anywhere on the screen by moving the mouse's positioning. The active pointer or cursor will move respectively.

## Remote Controllers

Not all controllers need to be physically connected to the Audio Presenter HUB. Computers, tablets and smartphones can also be used to remotely control the Audio Presenter HUB once your device is initially set up.

### App for Phones and Tablets

The Audio Presenter HUB can be controlled remotely via a tablet or smartphone through our app: Presenter Control.

Use the app to control the Audio Presenter HUB from your Apple device via Wi-Fi. The app allows you to display, share and annotate content from your Apple or Android tablet or phone, as well as from multiple video and computer sources connected to the Audio Presenter HUB. You can also change settings, switch video sources, and more.

This app can be downloaded from the Apple App Store.

Instructions for the use of the app are available on the Williams AV website, or within the app.

## From Your Browser

To connect to the Audio Presenter HUB from a browser, enter the IP Address of the Audio Presenter HUB into the browser.

The IP address of the Audio Presenter HUB can be found in the System Information (see System Information section) The Audio Presenter HUB must be connected to a network for this to work.

Once connected, a webpage with a stream from the Audio Presenter HUB will be visible. At the bottom of the webpage, a horizontal toolbar is available for quick annotation, video source switching and recording.

To access more advanced settings, add **/settings** to the URL. For example. 127.0.0.1/settings. For full documentation on the browser settings, please see “Adjusting Settings from the Browser” on page 55.

Currently, this feature is only available for Chrome, Firefox, Edge and Opera. It is not available for Safari.

**NOTE:** Browser streaming only works to browsers on desktop computers, and may not work on your mobile device. Please use our app on your mobile device.

## Toolbar

When using the touchscreen, browser or app, a toolbar is available to switch between sources and to quickly annotate. More features are available using the full menu system documented in this manual. There may be additional icons for in app and in browser features that are not listed here, such as using voice assistance, volume adjustment and calibration.



The pencil icon and the color bar.

### Clear All Marking



Clear all of the current annotations. The app will ask you to verify that you want to proceed.

### Erase Tool



Remove specific areas of your annotation

### Drawing Tools



Edit the appearance of your on-screen annotations.

### Line Size



Select small, medium or large

### Line Color

Select the color you want to draw with.



### White Board



Display a white board.

### HDMI



Display the HDMI source.

### USB Camera



Display the USB/Document camera.

### Streaming Input



Display the content streaming from a device, such as a laptop.

### Previous Slide



Display previous presentation slide.

In order for this to work, the Presenter HUB must be connected by Bluetooth to the slide presentation device. Powerpoint, Keynote or Impress presentations may be used. See “Bluetooth Features” on page 33.

### Next Slide



Display next presentation slide.

See *Previous Slide* for more details.

### Record



Record the presentation to a USB flash drive.

## Menu System

---

### Overview

There are two Audio Presenter HUB menus. One is a series of icons that runs along the bottom of the screen with commands a presenter would use frequently, such as changing marker color or video source. This menu is available by activating the hamburger icon at the bottom of the screen. This menu is documented in the App Icon Guide, available on the Williams AV website.

The other menu is a large, hidden main menu system mostly used for setup and configuration. This menu will need to be accessed to get your device connected to the network or calibrated properly. **The main menu system cannot be fully accessed from an App or Browser.**

## Using the Menu System

This section describes how to access the menu system and make selections from it.

### Menu Basics

If the keyboard is installed, it is the only way you can enter the menu system. If the keyboard is not installed, you can access the menu system from one of the other control devices.

The Main Menu appears over the video image.



Main Menu

### Activating the Menu

**Keyboard:** Press Setup Menu (Print Screen) key.

**NOTE:** Press the tip button soon after the barrel button, or the Audio Presenter HUB may interpret the barrel button press as a clear command.

**Touch Screen (or Whiteboard):** Tap upper center function area (or whatever function area you assigned for Menu access). This works only if no keyboard is connected.

### Menu Conventions

Once the menu system is displayed, you can make selections from it to navigate to the option(s) you wish to change. Each menu selection has the appearance of a rounded-corner button.

**Not Selected:** If a button is not selected, it has a black background.

**Selected:** When a button is selected, it changes to a blue background.

**Hovering:** As you move the selection arrow over a button (hovering), it will either

- Display blue behind the button text.
- Turn the text in the menu to white.

**Submenus:** A selection from the Main Menu causes a submenu to appear alongside it. A selection from the submenu sometimes displays a second submenu of choices based on the selection you make.

**Outline Format:** The entire menu system is an outline format that allows you to drill down to the specific option you wish to change. Whenever the Main Menu is visible, you can select directly from it to activate a different branch of submenus.

## Making menu selections

**Keyboard:** Use arrow to move to your selection and press the Enter key.

**Touch Screen, Whiteboard, or App:** Tap the screen over the option you want to select.

**Mouse Devices:** Click Left Button on your selection.

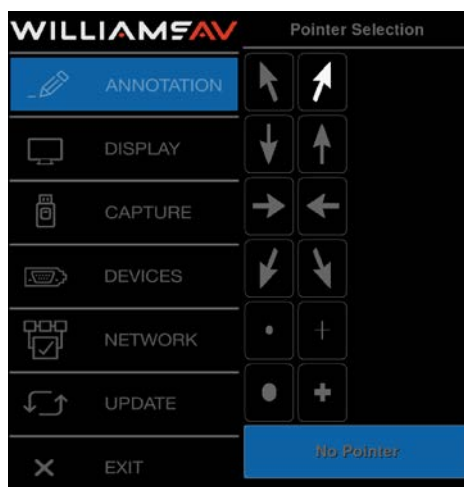

Sample Submenu

## Exiting Menus

Exit a submenu by selecting any option in the Main Menu. Exit the menu system by selecting **Exit**.

## Setting Default User Settings

1. Make your selections for the default settings using the menu system.
2. Re-boot the unit using the **CTRL-ALT-DEL** key command, or use the power switch to turn the device off and on.
3. When you see the Copyright screen during the boot process, press **CTRL-ALT-ENTER** to save your personal defaults. The screen will acknowledge that the settings have been saved.
4. The settings can be recalled at any time by pressing **CTRL-ALT-PgDn**.

## System Information

Certain menu items are used to view and update information about your Audio Presenter HUB.

### System Info

This selection presents a readout of relevant information concerning your unit. This information can be useful in troubleshooting, especially if you are contacting technical support.

1. Activate the menu system. The Main Menu appears.
2. Select **Display**. The Display menu appears.

### 3. Select **System Info**.

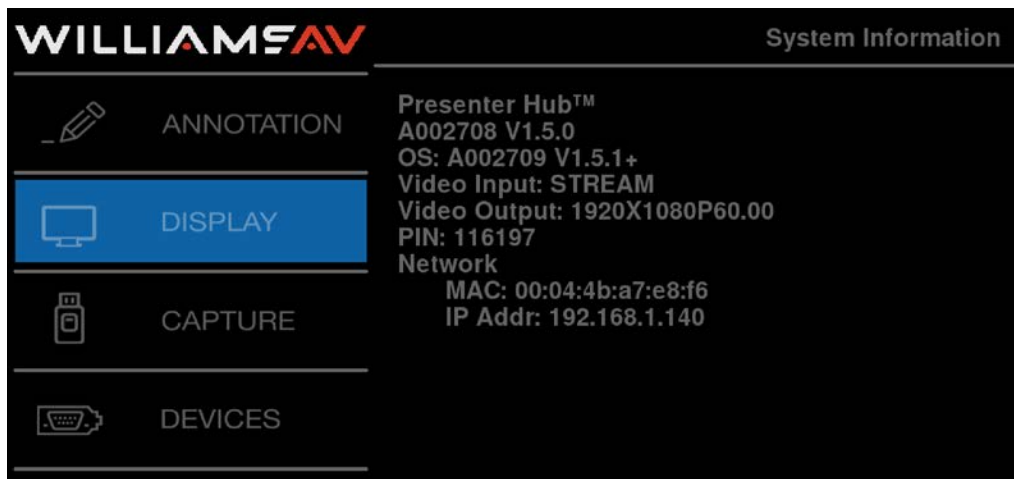

Example of System Information dialog

NOTE: Your numbers will be different than those of the menu above. Please write down all numbers when contacting technical support.

### Scheduling Restarts

The Audio Presenter HUB can be set to cycle the power at a set time of day. This will force the device to re-establish the connection with any controllers or screens connected to it. The time to power cycle can be set from this menu, as well as disabling or enabling the power cycling.

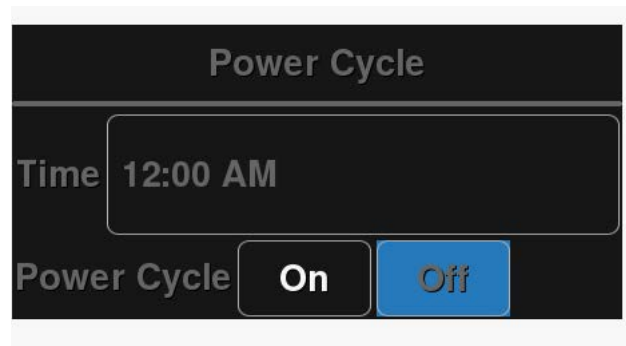

The Power Cycle Menu

## Detecting and Assigning Devices

Devices connected to any ports will often be autodetected by the Audio Presenter HUB. However, sometimes these devices will need to be manually added or need additional configuration.

### Serial Port Settings

Serial ports are used for connecting controller/marker devices and used for connecting to other systems. The Serial Port dialog also allows you to assign a priority system to control users if multiple controller/markers are connected.

### Initialization of Controller/Marker Device Types

Serial ports are initialized when the Audio Presenter HUB is powered on. During this process, the Audio Presenter HUB attempts to determine what device type is connected to each port. This procedure can be lengthy since the Audio Presenter HUB accommodates a wide range of devices, and in its default autodetect mode, it will run through the entire list of possibilities for each port.

**NOTE:** The Audio Presenter HUB can only automatically detect controller/marker device types; other devices will need to be set up manually.

It is possible to limit the initialization process for a designated port by permanently assigning the device type. The Audio Presenter HUB will look for only the permanently assigned device type. This speeds up the initialization process considerably. The next time the Audio Presenter HUB is powered up, the autodetect procedure will skip the permanently assigned port. If the assigned device needs to be initialized at startup, it will be initialized according to the device type listed.

### Viewing a Serial Device Type

1. Activate the menu system. The Main Menu appears.
2. Select **Devices**. The Devices menu appears.
3. Select **Serial Ports**. The Serial Ports menu appears.

**NOTE:** All the serial ports installed on your Audio Presenter HUB are listed by port number, with the device type displayed to the right of each number. If the device type is in blue, it has been assigned through the autodetect procedure at startup.

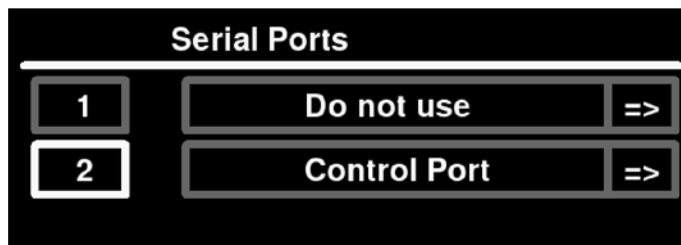

Example of Serial Ports menu

If the device appears to be assigned incorrectly and is not functioning, contact Tech Blue, Williams AV's technical support for assistance in getting your device working.

### Manual Serial Port Assignment

**WARNING:** The following process should only be performed when your Williams AV rep has directed you to do so. Doing so without guidance can corrupt your Audio Presenter HUB system and may require repair.

The Presenter HUB can also attempt to manually assign a device. This depends on the system having the correct driver installed on it; having the wrong driver may corrupt your system. **Do not do this process without the guidance of Tech Blue, Williams AV Tech Support.**

1. Select the device type you wish to have permanently assigned. If the device type can be permanently assigned (some types cannot), the color changes from blue to black.
2. Select the arrow to the right of the device type you wish to change. The Device Select menu appears. This dialog presents a scrolling list of all device types currently supported by the Audio Presenter HUB in alphabetical order. The Page Up and Page Down buttons allow you to quickly scroll through the names until you find the device type you desire.

When you locate and select the name you wish to assign, it will move to the center of the list, where it will be highlighted. The new device type is now assigned.

Device types which cannot be selected are in white.

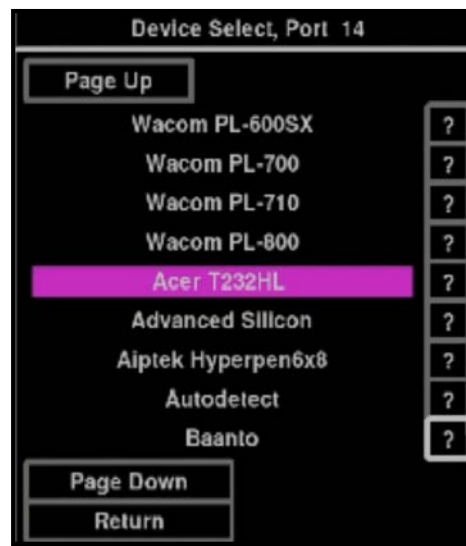

**Device Select menu**

When a ? button is selected, a screen with further information about that device type will be displayed.

If a device type that is used for communicating with other systems is selected, an arrow button will replace the ? button. Selecting that arrow button will activate the control port's submenu.

You can return to the Serial Ports menu to make further changes by selecting the Return button, or by selecting Input Devices and then selecting Serial Ports.

3. (Optional) Select the device type name you wish to change. **This method is only recommended for those with more extensive experience in assigning device types.**

When the device type name, instead of the arrow to its right, is activated, the device type will change without having to display the submenu. Each time the name is selected, it causes a different device type to appear. The list of devices available using this method is an abbreviated version of the list in the Device Select dialog.

A click on the right side of the name moves forward one device. A click on the left side of the name moves backward one device. Keep clicking until the device type you desire is displayed. It will be assigned permanently when the Audio Presenter HUB is rebooted.

If you are using the keyboard to select, it moves backward through the list only.

**NOTE:** If you are designating a port for use with another system, you will need to set COMM Port parameters before exiting the menu system. See the Setting COMM Port Parameters section.

4. Exit the menu system and recycle the power on the Audio Presenter HUB.
5. The Audio Presenter HUB must either be rebooted for the new device type assignments to be made permanent, **or** you can return to the Serial Ports dialog and select the numbered red box next to the new assignment to activate the device immediately.

## Viewing a USB Device Type

1. Activate the menu system. The Main Menu appears.
2. Select **Devices**. The Devices menu appears.



3. Select **USB Ports**. The USB Devices menu appears.

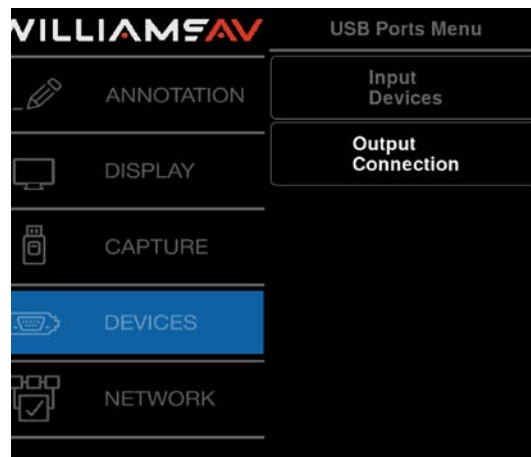

**USB Devices menu**

4. Select **Input Devices**. The USB Devices menu appears. 5 USB devices can be connected, and more could be added through the use of additional hubs.

NOTE: All the USB devices installed on your Audio Presenter HUB are listed by port number, with the device type displayed to the right of each number. If the device type is in blue, it has been assigned through the autodetect procedure at startup.

NOTE: When the ? button is selected, the system displays the vendor and product ID in the Device Select menu.



**Example of USB Devices menu**

If the device appears to be assigned incorrectly and is not functioning, contact Tech Blue, Williams AV's technical support for assistance in getting your device working.

## Manually Assigning a USB Device

**WARNING:** The following process should only be performed when your Williams AV rep has directed you to do so. Doing so without guidance can corrupt your Audio Presenter HUB system and may require repair.

The Audio Presenter HUB can also attempt to manually assign a device. This depends on the system having the correct driver installed on it; having the wrong driver may corrupt your system. **Do not do this process without the guidance of Tech Blue, Williams AV Tech Support.**

1. Select the device type you wish to have permanently assigned. The text color then changes from blue to black. For USB Devices, autodetect immediately detects and recognizes devices, even when their position on the hub changes. You might want to permanently assign a device type to a port if the device was marketed after your Audio Presenter HUB system was manufactured, or if the system misidentifies the device.
2. *(optional)* To manually change the device type, select the arrow to the right of the device type you wish to change. The Device Select menu appears.

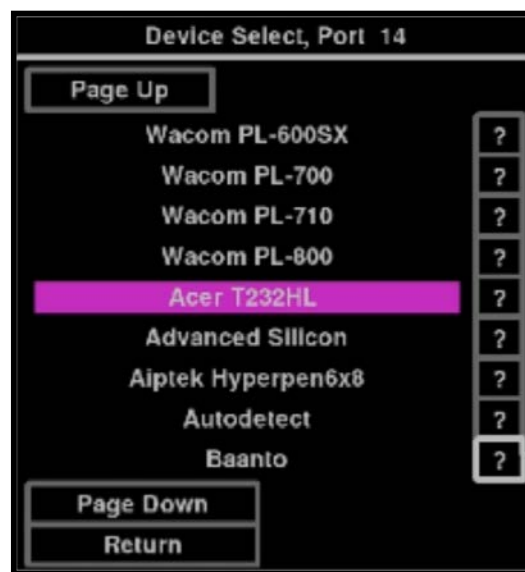

Example of Device Select menu

This menu shows a scrolling list of all device types currently supported by the Audio Presenter HUB in alphabetical order. The Page Up and Page Down buttons allow you to quickly scroll through the names until you find the device type you desire. When you locate and select the name you wish to assign, it will move to the center of the list, where it will be highlighted. The new device type is now assigned.

When a ? button is selected, a screen with further information about that device type will be displayed.

3. Select the **Return** button to view the Device Select dialog.

## Integrating the Audio Presenter HUB with Other Systems

Since only controller/marker device types are able to be recognized during the initialization process, all other devices must be set up manually. The Audio Presenter HUB allows you to manually adjust communication settings for either of its ports. This allows the Audio Presenter HUB to be integrated with

- an AV system as a control command station where it can both control AV devices and mark over any images presented.

- a control system which can send commands to the Audio Presenter HUB, controlling its various functions, like AMX/Crestron device.

## Setting COMM Port Parameters

If you are assigning a port for communicating with another system, you must select either **Control Port** or **PVI to PVI** as your device type. The Audio Presenter HUB supports assigning only one port for each type.

**Control Port:** Choose this option if the Audio Presenter HUB is being used as an AV remote control command station, if it is being controlled remotely using RS-232 commands, or if it is being connected to a PC.

**PVI-to-PVI:** Use this selection if the Audio Presenter HUB is being used in a videoconferencing system.

1. Select the appropriate device type in the Device Select menu for the port where you are connecting the other system. Where a question mark is usually found, you will instead see an arrow.

**NOTE:** Only one of the two COMM ports may be set to Control Port. Either COMM port may be set to Control Port, but only one at a time may be assigned as Control Port. If the device type you desire for connecting to other systems is unavailable, check to see if it is assigned to another port.

2. Activate the arrow next to the device type to set its communication parameters. The corresponding submenu appears. Select the desired baud rate, parity, and stop bits.

**NOTE:** Factory settings are 9600 baud, no parity, 1 stop bit. Data bits, which cannot be manually set, are 8 data bits.

3. Exit the menu system and cycle the power on the Audio Presenter HUB. The Audio Presenter HUB implements the new settings.

## Preparing Video Sources and Outputs

### Setting Video Output

The Audio Presenter HUB gives you a wide range of video parameters for fine tuning your video output.

1. Activate the menu system. The Main Menu appears.
2. Select **Display**. The Display menu appears.
3. Select **Video Output**. The Video Output dialog appears next to the Main Menu.
4. Select an **output ratio**. The associated Video Output Aspect Formats dialog appears next to the Main Menu.

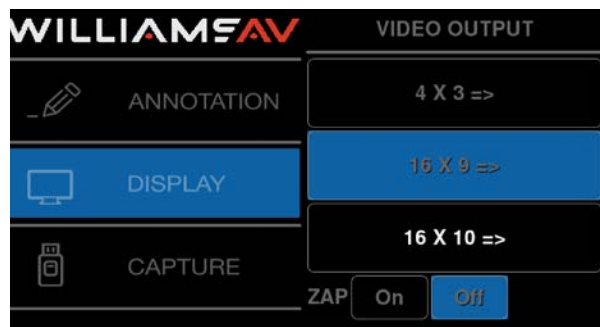

**Video Output Formats Dialog for 16 x 9 Ratio**

5. Select a **format**. The Audio Presenter HUB will immediately switch to the output format selected.
6. Exit the menu system.

## EDID

This dialog allows you to set the Audio Presenter HUB's preferred EDID resolution which tells the video source what resolution to send.

1. Activate the menu system. The Main Menu appears.
2. Select **Display**. The Display menu appears.
3. Select **EDID**. The EDID menu appears.
4. Turn **Force On or Off**. When off, the Audio Presenter HUB will not try to set the incoming source resolution. When on, select your desired resolution and the Audio Presenter HUB will force your device to output the set resolution.
5. Select an **EDID format**. The associated EDID Format submenu appears.

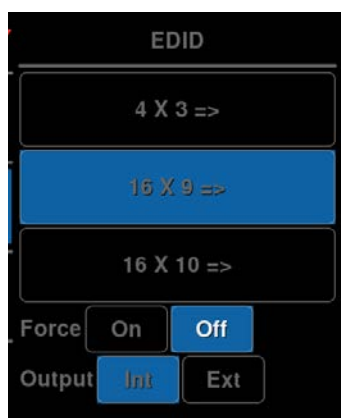

**EDID Submenu**

6. Set Output to Int (for Internal) to broadcast in 1080p video. If the Presenter Hub cannot send a 1080p signal, it will send s 1024 x 768 resolution video instead. Set Output to Ext (For External) to use the optimal resolution for connected, external devices.
7. Select a resolution.
8. Exit the menu system.

## Video Source Options

The Video Source menu allows you to select between your current Source Video or the Chalkboard background.

### From the Touch Screen, Browser or App:

1. Various video sources can be selected from this menu, including the chalkboard, document camera and HDMI video sources. See "Toolbar" on page 18 for more information.



**Video Source menu**

2. Select the option you desire.
3. Exit the menu system.

Alternatively, the video source many also be changed from the main menu.

1. Activate the menu system. The Main Menu appears.

2. Select **Display**. The Display menu appears.
3. Select **Video Source**.

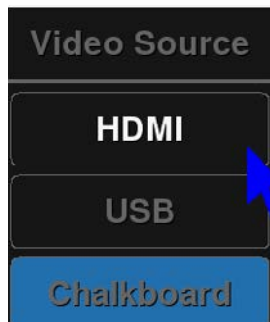

**Video Source Menu**

4. Choose from your desired video source. If streaming, choose the streaming format and input port number.
5. Exit the menu system.

### Default Video Source

Each time the Audio Presenter HUB starts, a specific video source can be selected as the default source to show. If the video source changes often, the last selected source used may be the desired default.

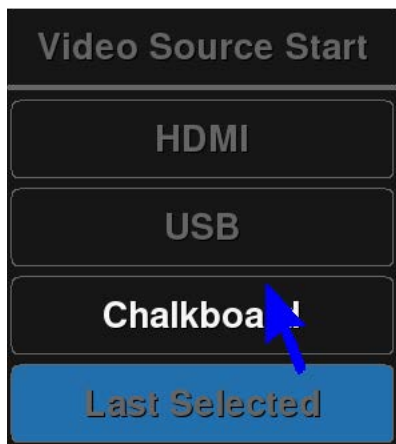

**The Video Source Start menu**

### Picture-In-Picture (PIP) Setup

Picture-in-Picture mode allows two images or videos to be shown at once.

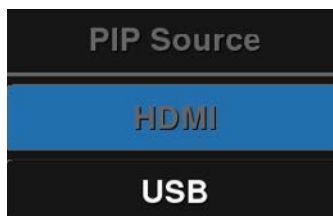

**The PIP Source Menu**

The Picture-in-Picture image or video can be provided via the HDMI or the USB. The chalkboard cannot be used as a source for Picture-in-Picture.

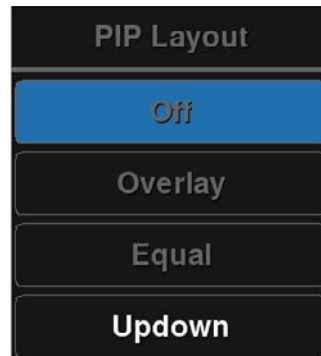

The PIP Layout Menu

The PIP Layout setting selects where the Picture-in-Picture will appear on the screen:

- Overlay will appear in the upper right
- Equal will split the screen, with both images/videos appearing side by side.
- Updown will appear in the top center

## Networking (TCP/IP, TFTP, SMB)

The networking capabilities built into the Audio Presenter HUB support various functions on a TCP/IP network. You can print to a printer, or send remote commands.

### Network Setup

1. Activate the menu system. The Main Menu appears. Select the **Network** option. The Network Menu appears.



Network menu

## 2. Select **Network Setup**.

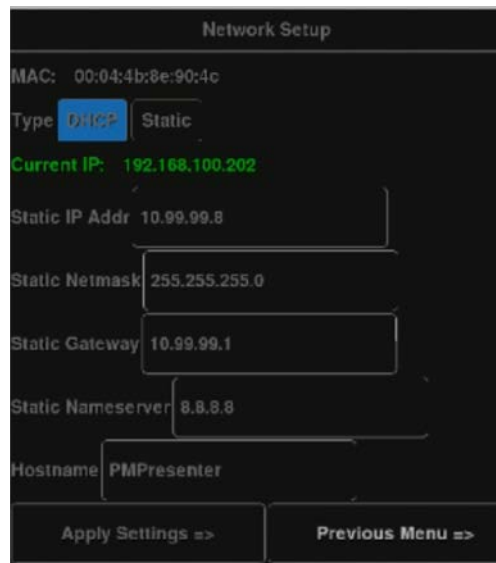

**Example of Network Setup menu**

The Network Setup menu appears. This dialog prepares the Audio Presenter HUB for communicating on your network.

### 3. Select DHCP or STATIC.

- If **DHCP** is selected, IP Address, Netmask, Gateway and Nameserver are assigned automatically.
- If **STATIC** is selected, you must make entries for IP Address, Netmask, Gateway and Nameserver. *(This is the default setting.)*

Consult with your IT administrator if you need help with these entries.

### 4. Select **Apply Settings** to finish the network configuration.

### 5. Exit the menu system.

## Configure TFTP Settings

The TFTP feature gives you the ability to save and retrieve images using the TFTP protocol. To save a file using TFTP, you must first install a TFTP server on the computer which will receive the file(s). You will need the IP address of the computer where TFTP is installed. Make sure your firewall does not block access to your TFTP server.

The following steps are required to allow the Audio Presenter HUB to communicate with the TFTP server.

1. Activate the menu system. The Main Menu appears.
2. Select the **Network** option. The Network Menu appears.

3. Select the **TFTP** option. The TFTP menu appears.

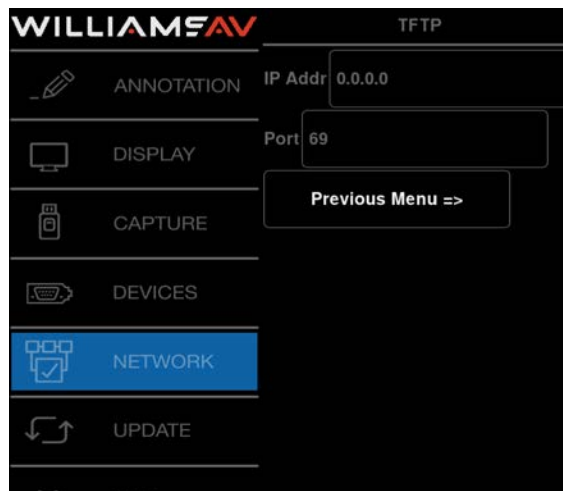

**TFTP menu**

4. Enter the **IP address** of the TFTP server. Check with your IT administrator if you do not know the IP address.
5. Enter the **Port number**. This is usually port 69. Check with your IT administrator if you are unsure.
6. Exit this dialog by selecting Previous Menu.

### Configure Windows Share (SMB) Settings

The Windows Share (SMB) feature gives you the ability to save and retrieve images using the SMB protocol. To save a file using SMB, you must first activate a Share on a server with the SMB protocol running.

The setup dialog requires a Server and Share name. If the Share is password protected, you will need the username and password. Make sure your firewall does not block access to your SMB share.

The following steps are required to allow the Audio Presenter HUB to communicate with SMB share.

1. Activate the menu system. The Main Menu appears.
2. Select the **Network** option. The Network menu appears.
3. Select the **Windows Share** option.

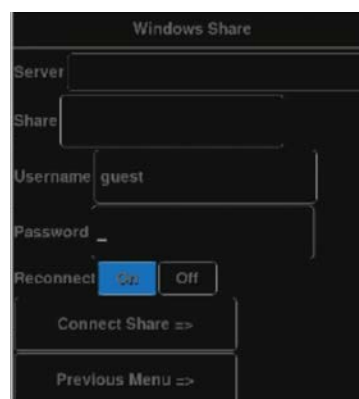

**Example of Windows Share menu**

Enter the **Server name** where your share is located. Check with your IT administrator if you do not know the name.

4. Enter the **Share name**. This is the name assigned to the location on the server. Check with your IT administrator if you do not know the name.



5. Enter the **Username and Password**, if any. Check with your IT administrator if you do not know this information.
6. Select the **Connect Share** button to connect the Audio Presenter HUB to the Windows Share. The Audio Presenter HUB will indicate if it is able to connect to your Share. If it fails, check your settings.
7. Exit this dialog by selecting Previous Menu.

## Security PIN

A 6-digit security number (PIN) can be enabled to prevent users without the PIN from viewing the stream in their browser or app. The PIN is visible on the main information screen of the Presenter HUB before streaming begins.

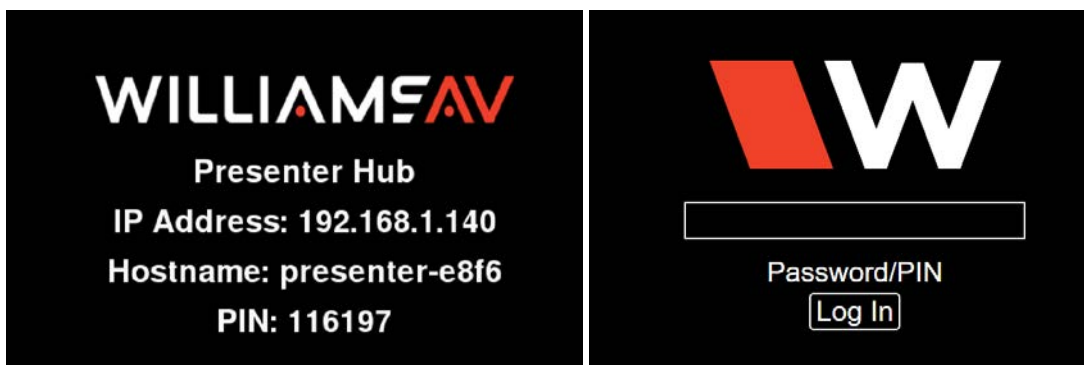

**The PIN is visible at to bottom of the connection information, and can be entered from the browser prompt.**

The PIN is a dynamic number, and will be automatically generated when enabled.

**Note:** When the system is rebooted, the PIN will change.

The PIN can be enabled or disabled from the web browser settings. In the browser settings section, see “System Settings” on page 59 for more information.

When a user views the stream from a web browser or from an app, the user will be prompted for the PIN before they can view or control the stream.

## Bluetooth Features

Bluetooth can be used to stream content and control presentations from your personal device. Slides from a slide show can be advanced or returned to via our app once a bluetooth connection is established.

### Finding the Bluetooth Network

When an Audio Presenter HUB system is set up on the network correctly with the B-WAP properly installed, the Bluetooth connection name will include network information.

1. Use a personal device with Bluetooth functionality to look at the list of available Bluetooth connections.
2. The Bluetooth network will be named similar to **Audio Presenter-[ABCD] [IP Address]**. For example, *Audio Presenter-3AB7 100.62.50.202* may be the connection name displayed.
3. The last section of the connection name is the IP Address. The middle section is the last 4 characters of the Audio Presenter’s MAC address.

*If the information in the connection name appears to be incorrect, you may need to configure your network using the network settings. See “Networking (TCP/IP, TFTP, SMB)” on page 30.*

4. Use the IP address or MAC address to find the device on your network.

## Connecting your Personal Device

To connect your phone or other personal device to the Audio Presenter HUB's Bluetooth network, follow the instructions from your device manufacturer to establish a Bluetooth connection. These instructions will differ per device.

The Audio Presenter HUB will be listed as an available device. Ask your IT administrator the correct name of your Audio Presenter HUB's Bluetooth network connection.

Only one Bluetooth device can be connected to the Audio Presenter HUB at a time. Additional sound sources will need to be connected via hardwired or other networked connections.

## Disconnecting your Personal Device

The Audio Presenter HUB will not remember device connections once an audio broadcast has ended. The next time you use the Audio Presenter HUB again, you will need to reconnect your device.

Phone calls will automatically be disconnected once the call has ended, preventing unwanted and unexpected audio broadcasts from private phone calls or other potential issues.

A timeout can be set up to disconnect all devices after a specified amount of time in silence has passed. This can be adjusted within the system settings.

Streaming music or other audio will not be automatically disconnected unless the timeout it hit.

To manually disconnect devices from the Audio Presenter HUB, follow the instructions for your personal device to shut off a Bluetooth connection.

## Streaming Content

A variety of content streaming services can connect to the Audio Presenter HUB, including Miracast, Chromecast and AirPlay.

If necessary, a WiDi antenna can be connected to the Audio Presenter HUB for streaming (*not included*).

**Note:** Miracast and the WiDi antenna is not available in all countries. Please check with your local Distributor.

Some devices require streaming via wi-fi while other stream over Bluetooth. Please read the instructions for your personal device to determine which connection is required to stream to the Audio Presenter HUB. The Audio Presenter HUB can handle Wi-Fi, WiDi, and Bluetooth connections. See "Bluetooth Features" on page 33 for more information on Bluetooth connections.

The instructions below provide guidelines for starting a stream from your device. These instructions may vary for your specific device.

### Airplay from IOS Devices

Some video players, like YouTube, will let you AirPlay right from the video panel. There'll be an AirPlay button on the bottom right of the video window menu. If that's unavailable, you can AirPlay simply by mirroring your screen from your Apple device:

1. Swipe up from the bottom of the screen to display the Control Center.
2. Tap **Screen Mirroring**.
3. Tap the **device** you'd like to AirPlay from.
4. When finished, repeat this process and tap **Stop Mirroring**.

### Miracast Stream from Android devices (if available)

To Miracast Stream from any Android device:

1. Swipe your finger down from the top of the screen to pull down the notification bar. You may need to slide your finger down twice to see the full details of the notification bar.
2. Tap on the **Smart View** or **Screen Mirror** icon. A list of nearby devices will be displayed.
3. If **Scan for nearby devices** displays, select it. The list of nearby devices will then appear.
4. In the list of nearby devices, you should see the Audio Presenter HUB. **Select it** and your device should begin streaming.

To disconnect the stream:

1. Swipe down from the top of the screen.
2. Tap on the streaming notification.
3. Select **Disconnect**.

### Miracast Stream from a PC (if available)

1. Open the Start Menu on your PC.
2. Click the **Settings** button in the bottom left corner of your screen.
3. The icon looks like a gear.
4. In the window that opens, select **Devices**.
5. Click on **Add Bluetooth or Other Device**.
6. Click **Wireless display or dock**.
7. A list of Miracast-enabled devices will appear. Your Audio Presenter HUB should be one of them.
8. Click on the name of the Audio Presenter HUB to stream your computer's display.

### Using Chromecast from a Google Chrome Web Browser:

1. Open Google Chrome web browser.
2. Click on the **Customize and Control** icon (three dots in a row), on the top right of your browser.
3. Click on **Cast** in the drop-down menu.
4. Click on the **triangle** beside Cast to.
5. Select **Cast tab** to cast only your browser, or **Cast desktop** to cast your desktop.
6. Select the Audio Presenter HUB to begin casting to it.
7. If you'd like to stop casting, click **Stop**.

### Streaming to Meeting Software or Screen Sharing Tools

Some meeting software may not let you stream directly from your personal devices to the meeting participants; however, you can screen share.

If your software allows screen sharing, you can stream the meeting content to the stream being shared.

1. Open up your remote meeting software or screen sharing tool.
2. Start a new meeting.
3. Open a browser.
4. Enter the IP Address of your Audio Presenter Hub (for further details, see "From Your Browser" on page 18).

- Using your meeting software, **share your desktop**.
- Stream any desired content to the Presenter Hub. Meeting attendees remotely viewing the screen sharing tool will be able to view content that appears in the browser window.

## Calibrating and Configuring Touch Screens

---

### Calibrating Touch Screen Controllers

Touch screens need to be calibrated on their first installation. Calibration ensures an intuitive and precise feel to drawing.

Calibrations are automatically saved for each video port. If you have a touch screen display with multiple video inputs, you should calibrate the touch screen for each input.

If you move a touch screen to a different port, run the calibration again.

All calibrations are stored in battery backed-up memory. The most recent calibration will be recalled any time power is cycled off and on.

### Calibration

#### From the Menu System

- Activate the menu system. The Main Menu appears.
- Select **Devices**. The Devices menu appears

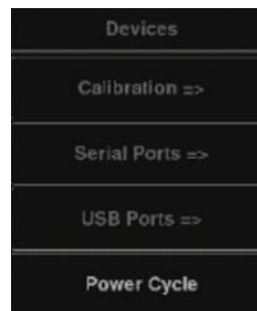

Devices menu

3. Select **Calibration**. The Calibration Menu appears.

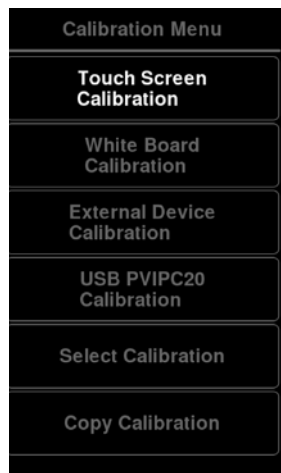

**Calibration Menu**

4. In the Calibration Menu, select the **controller** you want to calibrate. The calibration screen for the selected controller appears.



**Example of calibration screen**

5. Follow the calibration instructions displayed on-screen. As you touch the target, it will disappear and the next target will appear. Repeat until all 12 targets have been calibrated. After you perform final calibration procedures, the Calibration dialog automatically disappears, and you return to the menu system.
6. Exit the menu system. Repeat this process for each video input on your touch screen display.

### From the Browser

The browser will require calibration to draw on the Presenter HUB correctly.

To calibrate from the browser:

1. Log into the Presenter Hub from a browser.

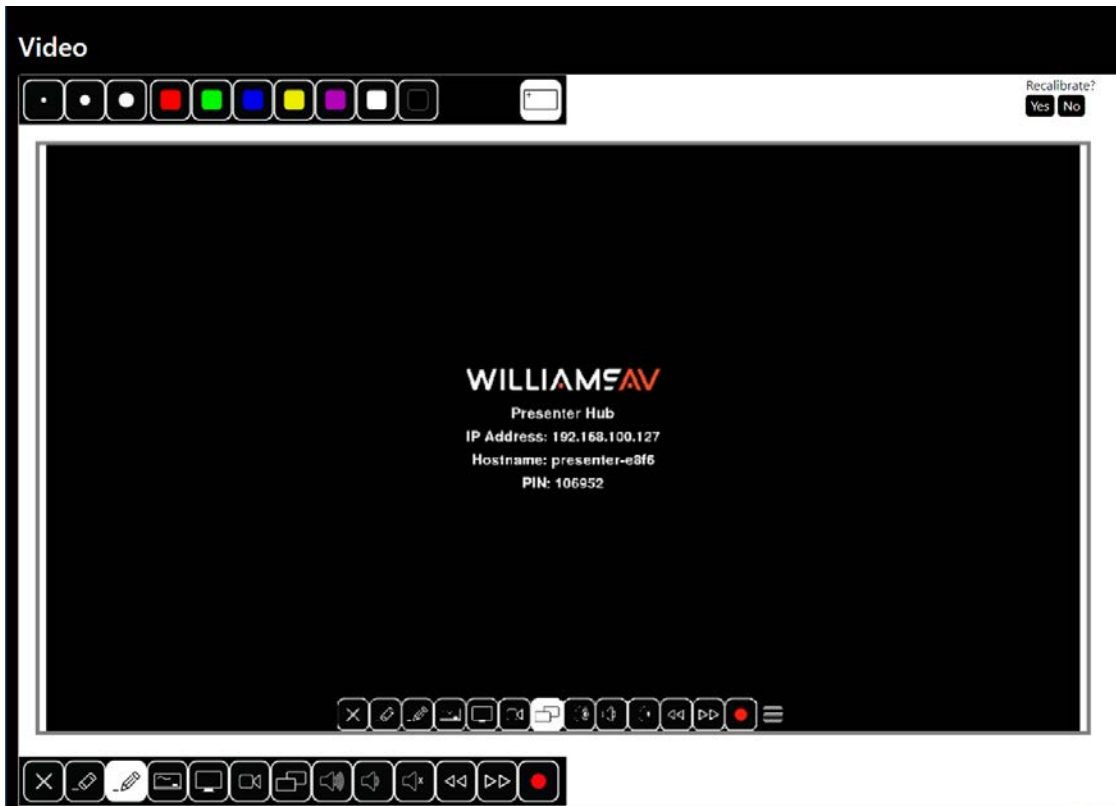

#### Calibration icons in the browser

2. Click the pen or erase tools in the *browser* toolbar. Do not use any toolbar displayed on the Presenter Hub display.
3. On the color or size selection bar at the top of the screen, click the calibration icon at the end of the bar.
4. A 'Recalibrate?' prompt will appear in the far right corner. Click yes.

5. Go through the calibration screen by clicking on the points with your mouse.

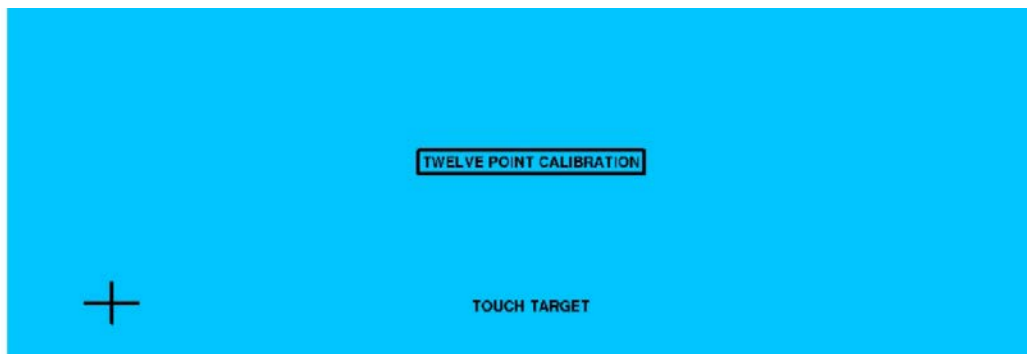

The browser calibration screen.

### Copying (Saving) a Calibration

For each video output, the Audio Presenter HUB has nine memory locations where calibrations can be stored for later recall. They are numbered 1 through 9. If you anticipate changing calibrations on a frequent basis, storing your calibrations in locations 1 through 9 makes it easy to change the active calibration without going through the calibration procedure and having to reboot the Audio Presenter HUB.

1. Activate the menu system. The Main Menu appears.
2. Select **Devices**. The Devices menu appears.
3. Select the **Calibration**. The Calibration Menu appears.
4. Select **Copy Calibration**. The Copy Calibration Menu appears.



Copy Calibration Menu

5. Choose the number under which you want to save the last manual calibration.

NOTE If there was a calibration previously stored in the location/number you select, it will be overwritten.

NOTE: Since the Audio Presenter HUB keeps only the location number, you may want to make a written record of which calibrations you have stored in each location.

6. Exit the menu system.

### Select a Calibration

When you are ready, you can choose to use a calibration you have previously stored.

1. Activate the menu system. The Main Menu appears.
2. Select **Devices**. The Devices menu appears.
3. Select the **Calibration**. The Calibration Menu appears.

4. Select the **Select Calibration**. The Select Calibration Menu appears.

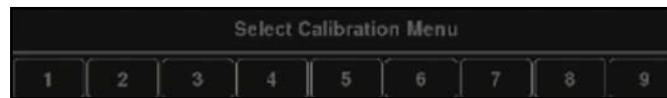

#### Select Calibration Menu

5. Choose the number under which you saved the calibration you desire to use. The calibration stored in that location becomes the active calibration.
6. Exit the menu system.

### Touch Screen Command Areas

This dialog allows you to assign touch screen commands to the various areas of your touch screen. Touching the screen in that area (after exiting the menu) will activate the command. Areas assigned to None are inactive.

1. Activate the menu system. The Main Menu appears.
2. Select **Display**. The Display menu appears.
3. Select **Touch Areas**. The Touch Areas menu appears.
4. Select **Touch Screen Areas**.

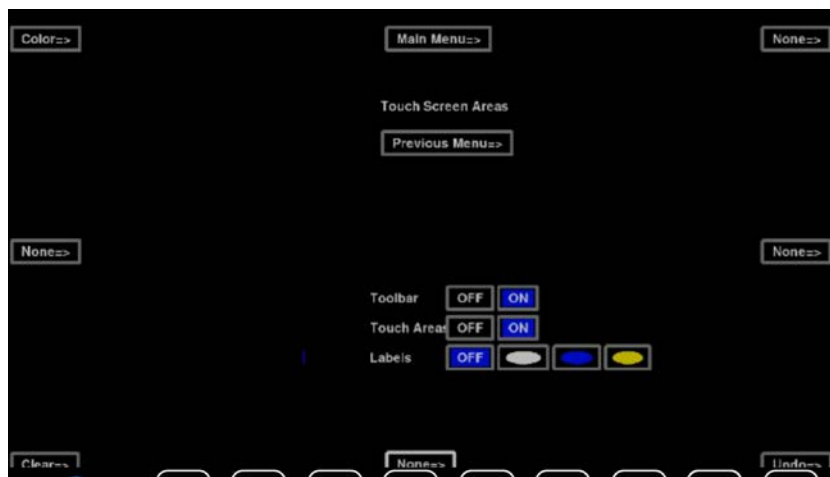

#### Touch Areas menu

5. Select one of the areas. The Touch Screen Area Select menu appears. Select the command you wish to assign.
6. Select **Previous**. The Touch Areas menu reappears
7. Repeat steps 4, 5, and 6 until you are finished assigning touch areas.
8. If you desire, you can turn off touch corner labels, or change their color to contrast with the video image using the menu in the middle of the screen.
9. When finished, select **Previous Menu** and exit the menu system.



## Customizing Markers and Pointers

This section covers the menu system functions that are usually set before making a presentation. Once set, the Audio Presenter HUB will save them in memory, even when powered down. Some of the functions can also be accessed directly through the keyboard.

The options commonly used during a presentation are covered in Using Markers.

### Customizing the Color Palette

During a presentation, all controllers allow you to select a marking color by cycling through each of the seven available colors. To streamline color selection, the Color Palette allows you to pre-select which of the Audio Presenter HUB's seven marking colors you wish to use during a presentation.

When the Color Palette command is activated, the seven colors appear over whatever video input signal is currently selected. This allows you to see how well the colors contrast with the image, making it easy to select colors that work well with the images you are presenting.

### Selecting Colors for a Presentation

#### From the Main Menu

1. Activate the menu system. The Main Menu appears.
2. Select **Annotation**. The Annotation Menu appears.

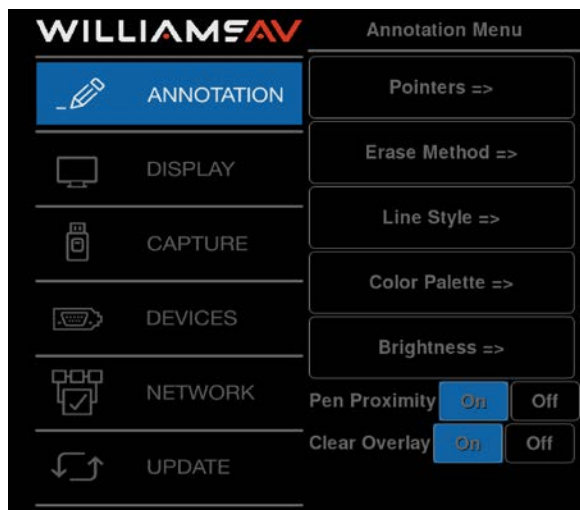

Annotation Menu

3. Select **Color Palette**. The Color Palette Menu next to the Main Menu.

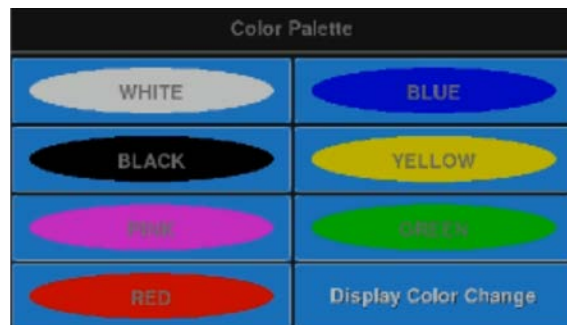

**Color Palette with all colors selected.**

4. Select the color or colors that you would like to have available during the presentation.

**NOTE:** These selections toggle on and off. Selected colors are surrounded by a solid white fill.

You must select a minimum of one color. If you select only one color, you will not be able to deselect that color until you select a second color in the menu.

5. Activate or disable the **Display Color Change** option.

If Activated, during presentations, a small block of color appears briefly in the lower-right of your display each time you activate the Change Color command. Normally, the active pointer will indicate the current color, but if the pointer is turned off, this small color block will show the current color instead.

**NOTE:** When enabled, this option will be surrounded by a white fill. If disabled, no color block will appear when the Change Color command is activated. Broadcasters and certain other presenters may desire this setting.

6. Exit the Color Palette Menu.

#### **From the Touch Screen, Browser or App**

1. Tap the pencil icon.
2. A bar will open at the top of the screen. You may select line thickness and color from here.



**The pencil icon and the color bar.**

### **Selecting a Brightness Level**

You can select a brightness level for all of the markers on an overlay. Adjusting the brightness creates optimum contrast between the Audio Presenter HUB graphics and the video image. The brightness selection is only applied to the current overlay, so there can be a different brightness level for each of the overlays.

Brightness is best controlled from the keyboard, but you can also adjust brightness with other devices using the menu system or the tablet template. Keyboard and tablet settings override any settings made in the menu system.

Be sure to display the overlay before adjusting the brightness so you can see the effects of the change.

#### **From the Tablet**

Activate the Brightness Command by pressing the tip button on the Brightness scale.

Selections to the left decrease brightness, while selections to the right increase brightness.

#### **From the Keyboard**

Repeatedly activate the Change Brightness command (F10) until the markers display the desired brightness level.

**NOTE:** You can move backwards through the brightness levels by activating the reverse toggle command (Shift +

Function Key).

Exit the Brightness mode by selecting any other function.

#### From the Menu System

1. Activate the menu system. The Main Menu appears.
2. Select **Annotation**. The Annotation Menu appears.
3. Select **Brightness**. The Set Brightness dialog appears in place of the Main Menu, featuring a transparent background that allows you to adjust brightness in accordance with your image.

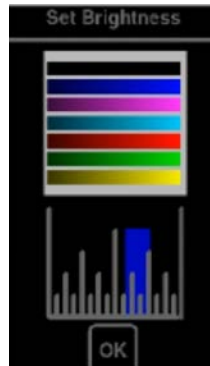

Set Brightness Dialog

4. Select the level of brightness you desire.

**NOTE:** Moving the indicator to the left will decrease brightness of markers and menus. Moving the indicator to the right will increase brightness. If the brightness is set too high for the display, the markers will smear across the image.

5. Click the **OK** button to exit the menu.

### Zap Icon Toggle

This feature is currently disabled on all systems, but may be returning in the future. If your software is displaying this menu option, no changes are occurring based on your choice.

## Using Markers

### Overview

The Audio Presenter HUB features a variety of graphics, called markers, which you place over a video image to draw attention to or explain details of the image. The markers available include freehand drawing and a variety of pointers. With the keyboard installed, you can type text, draw straight lines, and anchor a date/time label. You can place any combination of these markers on the screen, in any combination of available colors. Such a combination of markers is called a marker overlay. With the keyboard installed, you can save and retrieve up to 25 different marker overlays.

This section covers marking procedures to follow while making a presentation. It is assumed that you have made set-up selections sometime before your presentation.

### Assigning Marker Colors

The color that the active marker displays is the color that the marker will be anchored in. You can anchor markers of different colors on a single overlay.

The colors available during a presentation are based on those activated in the Color Palette menu.

If the color of the markers does not change from black, the brightness level is too low and must be increased before selecting the color.

#### From Any Controller

Activate the Change Color command from your control device.

All markers anchored from this point on will appear in the newly selected color.

**NOTE:** If the pointer has been disengaged, and the Display Color Change option in the Color Palette Menu has been activated, a small block of color will briefly appear in the lower right of the screen to help you identify the new marker color.

## Assigning Line Styles

You can change line style directly from the keyboard. You can also change the line style from other devices by accessing the menu system. When the keyboard is installed, you can only access the menu system from the keyboard.

When a line style is selected from a marking device, the Audio Presenter HUB keeps track of the style and the device. The device will draw with that style until a different style is selected. This allows each marking device to have its own line style. You can have drawn lines of different styles on a single overlay. Once you draw the line, or anchor a straight line, you cannot change that line style. However, you can erase or undo the drawing and begin again.

#### From the Keyboard

1. Activate the Line Style command. A small sample of the active line style will appear briefly in the lower-right hand corner of the screen.
2. Repeatedly activate the Line Style command until the desired line style appears in the on screen sample. You can scroll backwards through the line options, by activating the Reverse Toggle command.
3. All lines drawn from this point on will appear in the newly selected line width and style.

#### From the Menu System

1. Activate the menu system. The Main Menu appears.
2. Select the **Annotation** option. The Annotation menu appears.
3. Select the **Line Style** option. The Line Style Menu appears.



Line Style Menu

4. Select the desired **line thickness**, with or without a drop shadow.

**NOTE:** Drop shadows are always black, therefore, black lines do not have drop shadows.

5. Exit the menu system. All lines drawn from this point on will appear in the newly selected line width and style.

### From the Touch Screen, Browser or App

1. Tap the pencil icon.
2. A bar will open at the top of the screen. You may select line thickness and color from here.



The pencil icon and the color bar.

## Entering the Marking Mode

The Audio Presenter HUB is in the marking mode by default. The only time it is not in marking mode is when a menu is displayed. In the Marking mode, the image from the video source is displayed along with any stored markers. An active pointer is also displayed, unless it was disabled during setup.

## Drawing

You can draw on the overlay simply by beginning to draw. The drawing feature allows you to circle important parts of the image, write on the image, or underscore particular parts of text. You can draw freehand curves or straight lines.

To draw, you can use your finger on a touch screen. You can also use other mouse devices to draw. You cannot freehand draw using the keyboard, but you can use it for straight line drawing.

Before drawing, you may change the drawing line color or the width and style of the drawing line.

### Drawing Freehand

1. Position the active pointer (if one is displayed) anywhere on the video image where the drawing is to begin.
2. Activate the Draw command from your particular drawing device.
3. Reposition the active marker (if one is displayed) and repeat the above procedures for another drawn line.

### Straight Line Drawing

NOTE: This feature works only using the keyboard.

1. Activate the Straight Draw command from the keyboard. A cursor appears representing the first endpoint of the straight line.
2. Position the cursor anywhere on the screen where the line is to begin, and anchor it. A second cursor appears, joined by a line to the first endpoint.
3. Position the second cursor where the line is to end and anchor it. The line segment is complete.
4. If desired, draw another straight line by positioning the new active cursor and anchoring it.

## Selecting Pointers

You select a pointer type while the pointer is active, or positionable. After you anchor the pointer, you cannot change that pointer's type. However, you can erase or undo the anchored pointer and begin again.

### From the Keyboard

Repeatedly activate the **Pointers** command until the desired pointer type appears on screen. You can scroll backwards through the pointer options, by activating the Reverse Toggle command. The pointer you selected appears on screen, ready for positioning.

### From the Menu System

1. Activate the menu system. The Main Menu appears.
2. Select the **Annotation** option. The Annotation menu appears.

3. Select the **Pointers** option. The Pointers dialog appears.

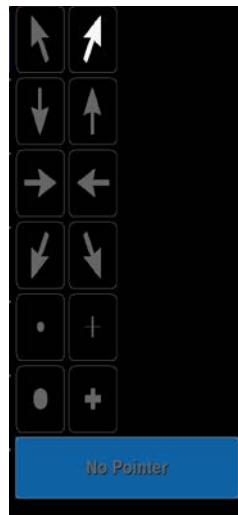

**Pointers dialog**

4. Select a pointer type. The active option displays a white fill. Selecting **No Pointer** turns the pointer off.
5. Exit the menu system.

## Creating a Pointer

You can move the pointer around the screen, using it to direct the viewer's attention without anchoring it. You can also position and anchor several pointers on the overlay, giving you the opportunity to point in a more lasting manner on several areas of the image.

Before using or anchoring a pointer, you may want to select a new pointer type. Or you may change the pointer color.

### From Any Controller

1. Position the pointer anywhere on the video image to direct attention to an image detail.
2. If desired, reposition the same active pointer anywhere on the image to make your second point, and continue as often as desired.
3. If desired, anchor the active pointer. A new active pointer appear on screen, identical to the first.

**NOTE:** Active pointers are not displayed for touch screens, only anchored markers.

4. Repeat any of these steps as often as desired.

## Turning the Active Pointer On/Off

Sometimes a presenter chooses not to have the pointer showing during a presentation. This command allows you to turn the visibility of the pointer off or on. When the active pointer is turned off, you can still anchor pointers.

**NOTE:** Since touch screens and whiteboards do not display active pointers, you do not need to use the Pointer On/Off command with those devices.

### From the Keyboard

Activate the Pointer On/Off command. The pointer disappears.

To make the pointer reappear, repeat the procedure.

**NOTE:** To turn off all active markers, use the keyboard Active Marker On/Off command.

### From the Menu System

Pointers are turned off in the same dialog where they are selected.

### Typing Text Labels

Anytime you press an alphanumeric key on the keyboard, a text label begins. Before you anchor a line of text, you can choose to display it in one of six fonts, each of which offers various sizes. These fonts are: TI Roman (4 sizes); Helvetica (4 sizes); TI Dom Casual (4 sizes); Fargo (3 sizes); Symbol (1 size); and Map (1 size). The Symbol and Map fonts are documented in the Appendices.

1. Position the active marker anywhere on the image.
2. Create a line of text by pressing the desired text keys.

**NOTE:** Do not anchor this line of text yet, since only an active line of text will display the font options.

3. Select the desired font by repeatedly activating the Fonts command until the font appears on screen. You can scroll backwards through the font options, by activating the Reverse Toggle command.
4. Select a font size by repeatedly activating the Font Size command until the correct size appears on screen. You can scroll backwards through the size options, by activating the Reverse Toggle command.
5. Turn the text background on or off by activating the Text Background On/Off command.

**NOTE:** The color of the background is always blue.

6. Position the active label anywhere on the video image, then anchor the label. The line of text is anchored. You can anchor a new line of text immediately below the previously anchored text line by not moving the cursor. Or you can position the second line of text anywhere on the screen.

**NOTE:** To create a paragraph of several lines of text, remember that text does not wrap, so press *Enter* or *Drop* at the end of each line.

7. Exit text typing mode by pressing any other function key.

### Displaying the Date/Time

**NOTE:** This feature works only using the keyboard.

You can place an overlay with the current date and/or time, depending on which display mode you selected in the Set Date/Time Menu.

While active, the date/time is represented by an icon. The numerical date and/or time will appear as soon as you anchor the icon. You can anchor only one Date/Time icon on each overlay.

To reposition an icon, activate the command again. The old icon disappears and the new icon appears, ready for positioning.

1. Activate the **Show Date/Time** command. A date/time icon appears.
2. **Position** the date/time icon anywhere on the video image.
3. To select a solid or transparent label background, activate the **Text Background On/Off** command.
4. Anchor the date/time icon. The current date/time icon appears.
5. A cursor appears on screen, ready for the next action.

### Clearing All Markers

Follow these instructions to clear the entire screen of markers. If you need to temporarily remove the marker overlay, then use the Marker Overlay On/Off command.

### From Other Controllers

Activate the **Clear** command for your particular controller. All markers disappear. An active pointer remains on screen unless the pointer has been disengaged.

## Undoing a Marker

To undo a marker, beginning with the most recently anchored marker or line segment. You can repeat this command as often as needed until the screen is clear of markers.

When you are in Undo Mode, you cannot erase markers.

### From Other Controllers

Activate the Undo command for your particular controller. The most recently anchored marker disappears. An active pointer remains on screen unless the pointer has been disengaged.

## Erasing Markers

Follow these instructions to erase markers from the overlay, wiping them clear like a traditional eraser. You activate Erase mode from the menu system, but you erase the markers using your drawing device.

When you are in Erase mode, you can no longer undo markers.

NOTE: Entering Erase mode clears markers from any overlays that you might have stored.

## Activating Erase Mode

### From the Main Menu

1. Activate the menu system. The Main Menu appears.
2. Select the **Annotation** option. The Annotation menu appears.
3. Select **Erase Method**. The Erase Method menu appears.

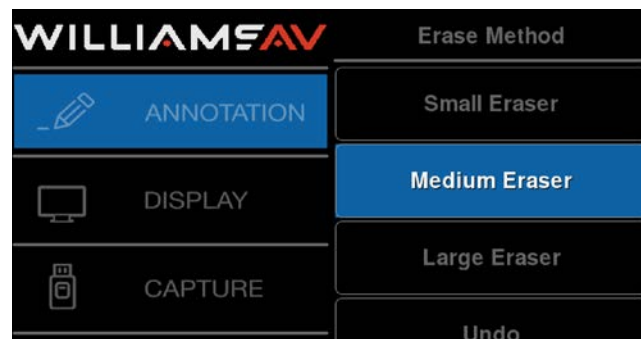

Erase Method Menu

4. Select an **eraser size**: Small, Medium, or Large.

NOTE: The larger the eraser size, the more area you can clear in a single motion. If you do not select an eraser size, the Audio Presenter HUB will default to Medium.

5. Exit the menu system.

### From the Touch Screen, Browser or App

1. Tap the Eraser icon on the bottom bar of the screen



2. Select the size of your eraser from the bar at the top of the screen.



The eraser icon and eraser size selection.

## Erasing

Be sure you are in Erase mode before following these steps. See Activating Erase Mode for instructions.

1. After marking, activate the **Undo/Erase** command for your particular controller. A square eraser appears on screen, ready for positioning.
2. Activate the **Draw** command, and drag the eraser over the markers. The markers disappear as you wipe. When you lift the drawing device, the Audio Presenter HUB closes the eraser function, and enters Marking Mode. If you need to erase again, repeat these steps.

## Using The Chalkboard

You can mark on a solid background, or chalkboard, instead of the video image. When turned on, the chalkboard will continue to be displayed, even when you select a new marker overlay. The chalkboard will remain on screen until you turn it off. The chalkboard is most easily selected from the menu system or keyboard.

### Activating the Chalkboard

Use these procedures to turn on the chalkboard.

#### From the Keyboard

Activate the **Chalkboard On/Off** command. The chalkboard appears, along with any markers you may have already anchored.

To close the chalkboard, press the **Chalkboard On/Off** command again. The video source returns, along with any markers you may have anchored on the chalkboard.

#### From the Menu System

1. Activate the menu system. The Main Menu appears.
2. Select the **Display** option. The display menu appears.
3. Select the **Video Source** option. The Video Source menu appears.
4. Turn the **Chalkboard** option On.
5. Exit the **menu system**. The chalkboard appears, along with any markers you may have already anchored.
6. To exit the Chalkboard, repeat these steps, but turn the Chalkboard option **Off**.
7. The video source returns, along with any markers you may have anchored on the chalkboard.

## Saving and Storing Images

### Overview

The Audio Presenter HUB makes it easy to access annotated or captured images, giving you newfound flexibility in the creation and sharing of your presentations.

It is now easy to capture images, with or without annotations, by either saving or printing them. Previously saved images can be retrieved from the storage device at will. You can also retrieve an image created on computer, as long as it conforms to the file specifications.

## Capture Options

A captured frame or field can be saved as an image to a USB memory device, to a computer running TFTP, or an SMB share. Files are saved in the bitmap format, 24 bit true color, with the extension .bmp. The captured frame will be the size of the screen resolution.

The File Defaults menu selection allows you to set the default settings for how the images are saved. It includes the directory, name and sequence numbering. This allows for fast saving with no dialog boxes involved.

1. Activate the menu system. The Main Menu appears.
2. Select **Capture**. The Capture menu appears.

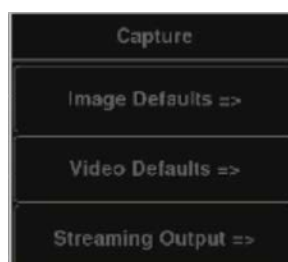

Capture menu

3. Select **Image** or **Video Defaults**. The selected menu appears.



Image File menu and Video File menu

4. In the **Dir** field, enter the directory name where you wish to save the file. It must be 8 alphanumeric characters or less, no spaces and no subdirectories. A default is entered automatically.
5. In the **Prefix** field, enter whatever letters you want each filename to begin with. The prefix must be 5 alphanumeric characters or less, no spaces. The default is entered automatically.
6. In the **Index** field, enter the number to start numbering from. Each time an image is saved, the number will increment. The default is 1. The numbering is remembered by the Audio Presenter HUB, even through cycling of power.

An example filename is img1.bmp. The next images would be img2.bmp, img3.bmp, and so on.

7. Exit by selecting the **Previous Menu** button.
8. Exit the menu system.

## Freezing Video

If video files are being shown as part of a presentation, the Audio Presenter HUB can freeze it at any point so you can draw attention to a particular frame's contents.

1. Activate the Freeze command in one of the following ways:

- **Touch screen:** Touch the **Top-Right** command area.
- **Keyboard:** Type **ALT+F1**.

The current video frame will be frozen on the screen. This command does not actually stop the video from playing. You will need to activate the **Pause or Stop** button on your video playback unit to do that.

2. You can now annotate the frozen image.
3. You can **Save or Print** the image at any time.
4. Activate the **Freeze** command again to toggle the command off. The running video will be displayed again.

## Setting the Destination for Saved Files

After setting up the file defaults for saving images, you will want to select the destination for your saved files. Files can be saved to USB memory devices, a computer running TFTP, or an SMB share.

1. Activate the menu system. The Main Menu appears.
2. Select **Capture**. The Capture menu appears.
3. Select the **Destination** as USB, TFTP or SMB. The Presenter will use your selection whenever you activate the Save command from the touch screen, or keyboard.
4. Exit the menu system.

## Setting the Verify Option

In circumstances where it is important to know that a file has been successfully saved or printed, this setting allows you to verify the end result. If you turn Verify on, a dialog will appear after each save or print command, asking you to verify that the image was successfully saved or printed.

1. Activate the menu system. The Main Menu appears.
2. Select **Capture**. The Capture menu appears.
3. Set **Verify** On or Off.
4. Exit the menu system.

## Saving Images

The Audio Presenter HUB can save displayed images in the following ways:

- moving images can first be frozen and then saved.
- a single frame of a moving image can be captured on-the-fly as it goes by on the screen.
- any still image can be saved.

The image can be saved to a USB memory device or to another computer using TFTP or SMB (Windows Share).

The image is saved based on the settings you've chosen. Files are saved in bitmap format, 24 bit true color with the extension .bmp. The captured frame will be the size of the screen resolution.

The USB memory device must be a single device, like a memory stick. It cannot be connected through a multiple port memory card reader. It must also be formatted as FAT16 or FAT 32.

### To save an image file to a USB device

1. Save the image file in one of the following ways:
  - **Touch Screen:** Touch the **Image Save** command area (center-left).

**NOTE:** Be sure the Capture File Defaults has been set to USB. If you want to use the tablet or touch screen commands, be sure to set the Destination to USB first.

- **Keyboard:** Type **ALT+F2**. The ALT+F2 keyboard command is programmed to save to the USB device. The other two commands are dependent on the Destination setting in the Capture dialog.
2. The image is saved to the USB memory device. A counter appears at the lower-right portion of the screen, indicating the percentage of the image saved to the USB storage device. When the counter reaches 100, it disappears. The system is then ready to save another image. The name of the file is determined by the settings in the File Defaults dialog.

### To save an image file using TFTP

To save a file using TFTP, you must first install a TFTP server on the computer which will receive the file(s). See Configure TFTP Settings.

The name of the file is determined by the settings in the **File Defaults** dialog.

1. Save the image file in one of the following ways. If you want to use the tablet or touch screen commands, be sure to set the Destination to USB first.
  - **Touch Screen:** Touch the **Image Save Command** area (center-left). Be sure that Capture File Defaults has been set to TFTP.
  - **Keyboard:** Type **ALT+F6**. The ALT+F6 keyboard command is programmed to save to the Computer where TFTP is installed. The other two commands are dependent on the Destination setting in the Capture dialog.
2. The image is saved to the computer you have designated. A counter appears at the lower-right portion of the screen, indicating the percentage of the image saved to the TFTP server. When the counter reaches 100, it disappears. The system is then ready to save another image.

**NOTE:** Operation of the Audio Presenter HUB will slow down during the saving process.

### To save an image file using Windows Share (SMB)

To save a file using SMB, you must first install and setup Windows Share on the computer. See **Configure Windows Share (SMB) Settings**.

The name of the file is determined by the settings in the File Defaults dialog.

3. Save the image file in one of the following ways:
  - **Touch Screen:** Touch the **Image Save Command** area (default is center-left). Be sure that Capture File Defaults has been set to SMB.
  - **Keyboard:** Type **ALT+F8**. The image is saved to the computer you have designated. A counter appears at the lower-right portion of the screen, indicating the percentage of the image saved to the computer. When the counter reaches 100, it disappears. The system is then ready to save another image.

**NOTE:** Operation of the Audio Presenter HUB will slow down during the saving process.

## Retrieving Images

### To retrieve an image file from USB

1. Retrieve an image in one of the following ways:
  - **Touch Screen:** Touch the appropriate area if you assigned this command.

- **Keyboard:** Type **ALT+F3**.
2. The **Get Image** dialog appears. Select the image you wish to retrieve from the list that is presented. The image is displayed on the screen.

### To retrieve an image file using TFTP

1. Type **ALT+F7** on your keyboard or touch the area on your touch screen if you assigned this command. The Get Image dialog appears.
2. Enter the image index number for the image you wish to retrieve and select OK.

Only the number is to be entered. The prefix of the file is determined by the settings in the Image File dialog. If you have changed the prefix setting in order to help group files for a particular purpose, make sure the prefix in the Image File dialog matches the prefix of the file you are attempting to retrieve. The file extension must be .bmp.

The image is displayed on the screen.

### To retrieve an image using Windows Share (SMB)

1. Retrieve an image in one of the following ways:
  - **Touch Screen:** Touch the appropriate area if you assigned this command.
  - **Keyboard:** Type **ALT+F3**.

The Get Image dialog appears.

2. Select the image you wish to retrieve from the list that is presented. The image is displayed on the screen.

## Printing Images

The Audio Presenter HUB allows you to print to a printer either directly or over a TCP/IP network. If you print directly, the configuration requires a USB to Centronics cable. To print over a TCP/IP network requires an Ethernet cable and the address of the printer.

### Printer Setup

The Audio Presenter HUB can print to a printer over a TCP/IP network. This section shows you how to set it up.

1. Activate the menu system. The Main Menu appears.
2. Select the **Network** option. The Network Menu appears.
3. Select the **Printer** option. The Network Printer dialog menu.

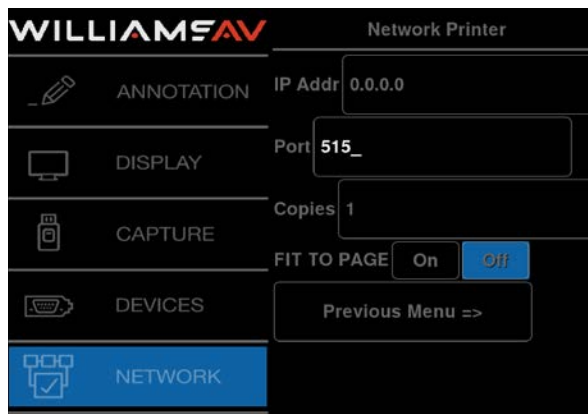

Network Printer menu

4. Enter the **IP address of the printer**. Check with your IT administrator if you don't know this address.

5. Enter the **Port number**. This is usually 515.
6. Enter the **number of copies** to be printed each time you give the Print command.
7. Exit this dialog by selecting **Previous Menu**. The next time you give the Print command, it will use these settings.

## Print an image

1. Print an image in one of the following ways:
  - **Touch Screen:** Touch the appropriate area if you assigned this command.
  - **Keyboard:** Type **ALT+F4**.
2. The image is sent to the printer. A counter appears at the lower-right portion of the screen, indicating the percentage of the image sent to the printer. When the counter reaches 100, it disappears. The system is then ready to print another image.

## Verifying Saved or Printed Images

In circumstances where it is important to know that a file has been successfully saved or printed, you will want to activate the **Verify** setting. Once it is active, each time you print or save a file, a dialog will appear, asking you to verify that the image was successfully saved or printed.

## Updating the Audio Presenter HUB

The Audio Presenter HUB firmware can be updated through USB or TFTP to provide new features, improve functionality or bug fixes.

**NOTE:** The Audio Presenter HUB must be connected to the internet to update, even when updating from a USB device.

Before activating the Update command, the update file must be copied into a directory on the flash drive or TFTP location called **BIUUPG**. Create this directory directly under the main (Root) directory. It cannot be inside any other folder. Ensure there is an internet connection to the Audio Presenter HUB before starting the update.

1. Before activating the Update command, the update file must be copied into a directory on a USB flash drive or in TFTP location named BIUUPG. You must **create the BIUUPG directory in the root directory**.
2. Activate the menu system. The Main Menu appears.
3. Select **Update**. The Update dialog appears.

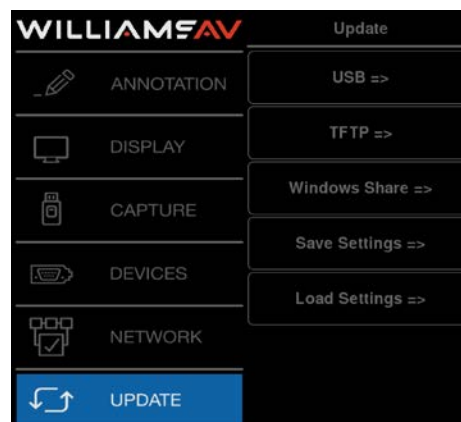

Update dialog

4. Select **USB or TFTP**, depending on where you have placed the update file. The screen will display various information as the update takes place. Then it will request that you cycle the power.

NOTE: Do not shut off the device, remove the update file, or restrict access to the update file until the update is finished.

5. Turn the Audio Presenter HUB off, then turn it back on. The system will start up using the new firmware.

## Adjusting Settings from the Browser

Many settings can also be adjusted from the browser. The Audio Presenter HUB can be accessed from the browser by typing in the IP address of the device followed by /settings. See “From Your Browser” on page 18 for more information.

### Streaming Menu

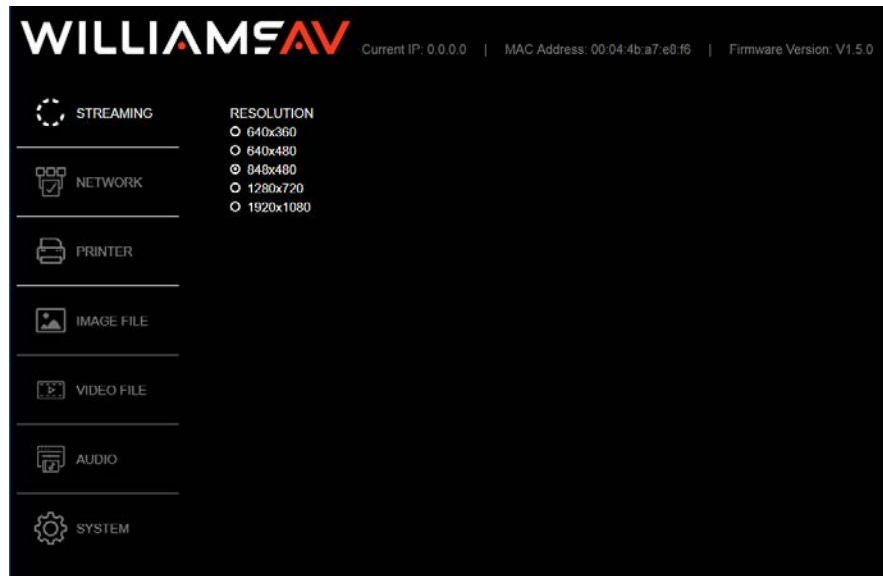

The Streaming Menu

The streaming menu allows for the selection of the resolution of the stream for the browser.

## Audio Menu

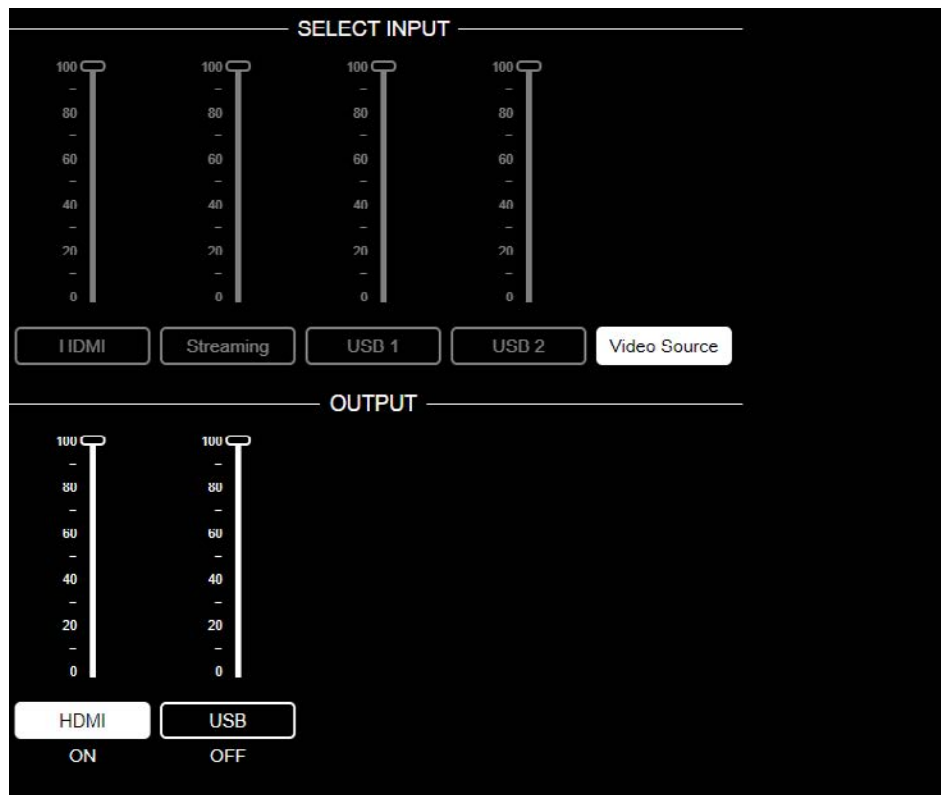

### The audio menu

The audio menu can adjust the source of any incoming stream audio, and also control the output of the audio.

The type of input and the type of output can be selected. The volume level of the audio can be raised or lowered to a more acceptable level.



## Network Settings

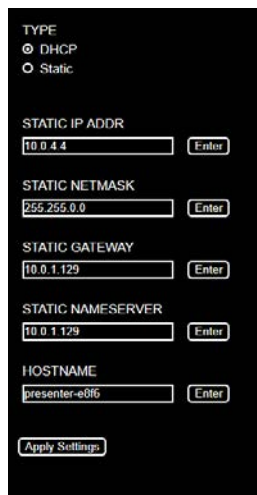

TYPE  
 DHCP  
 Static

STATIC IP ADDR  
10.0.4.4 Enter

STATIC NETMASK  
255.255.0.0 Enter

STATIC GATEWAY  
10.0.1.129 Enter

STATIC NAMESERVER  
10.0.1.129 Enter

HOSTNAME  
presenter-e016 Enter

Apply Settings

**The network settings menu**

The network settings of the device can be adjusted from the browser. Adjusting the network settings from the browser will work similarly to adjusting these settings directly on the Audio Presenter HUB. For assistance adjusting these settings, see “Networking (TCP/IP, TFTP, SMB)” on page 30.

**Note:** Adjusting the IP address of the Audio Presenter HUB may make the website unavailable. Be sure you have proper access to the device to prevent being able to reconnect to the device’s website.

## Printer Settings



IP ADDRESS  
0.0.0.0 Enter

PORT  
515 Enter

COPIES  
1 Enter

FIT TO PAGE  
 On  
 Off

**The printer menu**

The printer can be selected from the browser. Adjusting the printer settings from the browser will work similarly to adjusting these settings from directly on the Audio Presenter HUB. For assistance adjusting these settings, see “Printer Setup” on page 53.

## Image File



The screenshot shows a configuration menu on a black background. It contains the following sections:

- DIRECTORY**: A text input field containing "PVI" and an "Enter" button.
- PREFIX**: A text input field containing "IMG" and an "Enter" button.
- INDEX**: A text input field containing "25" and an "Enter" button.
- DESTINATION**: Three radio button options:  USB,  TFTP, and  SMB.
- VERIFY**: Two radio button options:  On and  Off.

**The Image Menu**

The image menu is used to set where any saved images will be stored. Adjusting the image settings from the browser will work similarly to adjusting these settings directly on the Audio Presenter HUB. For assistance adjusting these settings, see “Saving and Storing Images” on page 49.

## Video Menu

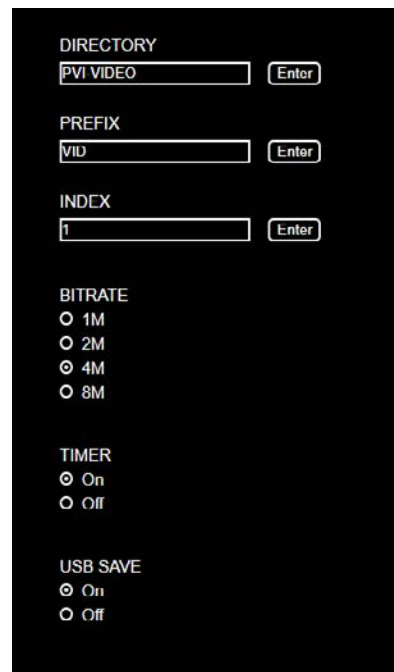

The screenshot shows a configuration menu on a black background. It contains the following sections:

- DIRECTORY**: A text input field containing "PVI VIDEO" and an "Enter" button.
- PREFIX**: A text input field containing "VID" and an "Enter" button.
- INDEX**: A text input field containing "1" and an "Enter" button.
- BITRATE**: Four radio button options:  1M,  2M,  4M, and  8M.
- TIMER**: Two radio button options:  On and  Off.
- USB SAVE**: Two radio button options:  On and  Off.

**The Video Menu**

The video menu selects where video is saved and other video storage settings. This menu does not affect streaming quality. Adjusting the video settings from the browser will work similarly to adjusting these settings directly on the Audio Presenter HUB. For assistance adjusting these settings, see “Saving and Storing Images” on page 49.

## System Settings



The System Menu

The system can be updated from this screen. For more information on system updates, see “Updating the Audio Presenter HUB” on page 54.

The security PIN feature can also be turned on from this screen. See “Security PIN” on page 33 for more information on using the PIN feature.

## Connecting Personal Devices

Personal devices do not require any special set up in order to be used; personal devices only need to make a Bluetooth connection, streaming connection, or wired connection to the Audio Presenter HUB. For further instructions on making connections to the Audio Presenter HUB, see the table of contents to help find instructions for your type of device or connection.

View your device manufacturer’s instructions for how to make Bluetooth or streaming connections from your specific personal device. These instructions will differ per device.

## Glossary

### ACTIVE MARKER

-- the pointer, text label or date/time label which is positionable. Often used as a marker, but also used to position the starting point of a drawing line. When the active marker is anchored, another identical active marker appears on-screen. One active marker is always displayed, unless the marker has been turned off.

### ANCHORED MARKER

-- the opposite of an active marker. An anchored marker has been placed in a fixed position on the overlay and cannot be moved again. However, anchored markers may be erased or cleared.

### BLUETOOTH WIRELESS ACCESS POINT (B-WAP)

-- a transceiver that can sit on the wall or ceiling that broadcasts a 50 ft (15.24 m) radius of bluetooth signal.

### BACKGROUND

-- text background refers to the area immediately surrounding a line of text or a text label. For video background, see **Chalkboard**.

### BLOOM

-- markers or text which enlarge or blur on the monitor due to excessive brightness.

### BUTTON, TABLET

-- the square or rectangular zone on the tablet Menu Strip that represents a Audio Presenter HUB function. When this zone is clicked on with the pen tip, that function is engaged.

**CHALKBOARD**

-- the solid area behind the markers when in the Chalkboard mode. Presenters may choose a source background or a solid background.

**CLEAR**

-- removing all the overlay of all markers at once. A single active marker will remain on-screen unless the marker has been disabled.

**CLICK**

-- quickly depressing and releasing a button on the auxiliary controller, as opposed to a press of the button.

**COLOR PALETTE**

-- a user-defined group of colors which may be attributed to each active marker before anchored. From 1 to 7 colors are available.

**COMM PORT**

-- a serial port used for communications. Serial devices that connect to these ports (such as a mouse or touch screen), send and receive data in single bits of information one after the other, thus the term serial.

**CONNECTOR**

-- hardware installed on cable ends to provide cable attachment to an input or output device. Input and output device ports which mate with this hardware are also called connectors.

**CONTROLLER**

-- a device that controls the selection, positioning, anchoring and clearing of markers on the overlay. Some other compatible controllers are most touch screens and certain mouse devices.

**DRAW**

-- freehand drawing or writing over a video or computer image.

**DROP SHADOW**

-- a shadow on drawing lines, or straight lines for the purpose of creating a line that stands out from the video image. Most colors have a black drop shadow. Black has no drop shadow.

**ERASE**

-- remove markers from the overlay, rather than undo them using an on screen eraser. Erasing has the same effect as erasing with a pencil or chalkboard eraser; only the markers you touch (or parts of them) will erase.

**FONT**

-- a particular style of text such as Helvetica or Times Roman. The fonts installed in the Audio Presenter HUB are available in one or more sizes.

**ICON/BUTTON, TABLET**

-- see button, tablet.

**MARKERS**

-- pointers (arrows, cross hairs, dots), date/time labels, freehand drawings and straight lines which can be placed and anchored on a marker overlay.

**OVERLAY**

-- a combination of one or more markers placed on the screen using the capabilities of the Audio Presenter HUB. These markers overlay a chosen video image. While the markers are visible, the actual overlay is invisible, allowing you to mark directly on top of a video image (or solid background if selected in the menu system).

**POINTERS**

-- the different arrows, cross hairs and dot pointers which may be selected and placed on an overlay, in any number and in combination with other markers. Pointers are considered markers. However, not all markers are pointers.

**PRESS**

-- on the keyboard, the action of pressing then releasing the function key. On auxiliary controllers, a press is often the action of depressing and not releasing a button until the desired effect takes place on the screen (as opposed to a click of the button).

**PROXIMITY**

-- on a tablet, when proximity is activated, the active pointer automatically disappears each time the pen is lifted from the drawing area.

**UNDO**

-- remove anchored markers on an overlay one at a time, beginning with the most recently anchored marker.

**VIDEO SOURCE**

-- a device from which the Audio Presenter HUB receives a video image, incorporates the graphic overlay capabilities, then outputs to the corresponding display. Examples of video sources include DVD players, cameras, VGA computers, standard television sets, teleconference equipment, slide-to-video converters, visual presenters and more. In the Audio Presenter HUB model, the source can be from HDMI or USB.

## Troubleshooting Guide

The following table describes common problems and their solutions. If, after referring to this table, a problem still exists, call Williams AV and ask for technical assistance.

There are no user serviceable parts in the Audio Presenter HUB. Do not open the cabinet.

The Audio Presenter HUB can be soft booted/power cycled by pressing CTRL + ALT + DEL. Factory default settings are restored by pressing CTRL + ALT + END.

**WARNING:** executing a factory reset will erase all user settings including calibrations, COMM port settings, etc.

SYMPTOMS	POSSIBLE SOLUTIONS
The green indicator light on the front of the Audio Presenter HUB does not light up.	Check that the Audio Presenter HUB is plugged into a live outlet.
Monitor does not light up.	Check that the monitor is plugged into a live outlet. Check that the monitor is switched on. Check that the monitor brightness and contrast controls are properly adjusted.
The Audio Presenter HUB markers appear to bloom.	Adjust system parameters on the video output device, monitor, or camera (if in use) such as contrast, gain, brightness, color, light, and intensity. Decrease brightness of the markers or use a different marker color.
Monitor lights up but does not display a picture.	Check that the video source and Audio Presenter HUB are each plugged into a live outlet. Check that the video source and Audio Presenter HUB are both switched on. Check that the proper cables are connected to the proper connectors on the video source, the Audio Presenter HUB, and the monitor. Some sources and monitors have multiple output and input connectors. Consult your video or computer manuals for correct connection information. Bypass the Audio Presenter HUB by connecting the monitor directly to the video source. If the video image still does not appear, have the video source and monitor checked.
Monitor automatically adjusts brightness so that video image is dull while markers are bright.	Monitor is automatically adjusting for the overall brightness level of the markers and the video image. On the Audio Presenter HUB, activate the Change Brightness command. Tone down the brightness level of the markers. The monitor will adjust accordingly.
Monitor displays a scrambled picture.	Check the horizontal hold control on the video monitor for proper adjustment. Check that the Dual Voltage Switch (110V/220V) located on the back panel of the Audio Presenter HUB is properly set. Monitor is not compatible with video source. Use compatible system. Check to be sure that the video in and out connectors are secure.
Mouse device will not operate properly.	Refer to the specific section in this manual that describes installation of your controller.
Touch screen will not operate properly.	For touch screens, you may need to calibrate settings. Refer to Calibrating Touch Screen Controllers in this full user manual.

SYMPTOMS	POSSIBLE SOLUTIONS
PC display scrolls.	<p>You may need to adjust your computer's Display or Monitor Type setting for a video scan rate compatible with the Audio Presenter HUB.</p> <p><b>For display utilities that permit the user to change the horizontal scan rate or vertical refresh rate:</b>  Select a resolution, maximum horizontal scan rate, and a maximum vertical scan rate that are compatible with the computer hardware, the Audio Presenter HUB, and the display monitor/projector. You will need to restart the computer before changes can be activated.</p> <p><b>For Windows 7/8/10 Display Settings that permit a change in monitor type:</b>  If an independent display utility or video driver was not installed, you may want to change the display type by using the settings commands in Windows 7/8/10.</p> <ol style="list-style-type: none"> <li>1. Go to the Display settings for your system.</li> <li>2. In the Display window find the Screen Resolution listing.</li> <li>3. Select the desired resolution.</li> <li>4. With some operating systems you may need to click <b>Apply</b> for the change in resolution to take effect. Some operating systems update automatically.</li> </ol>

## Appendix

### Quick Reference for Keyboard

The commands in these tables are for a keyboard when used with the Audio Presenter HUB.

MARKING COMMAND	KEY
Date/Time Display	F8
Date/Time Setup	CTRL + F8
Font Selection for Text Labels (typed text)	F6
Font Size for Text Labels (typed text)	CTRL + F6
Line Style Selection	F2
Straight Line Draw	F5
Text Labels (typed text)	AlphaNumeric Keys
Text Background On/Off	F7

ACTION (OPS) COMMAND	KEY
Anchor Marker	Insert
Change Brightness	F10
Chalkboard On/Off	F11
Clear All Markers	End
Color Change of Active Marker	F9
Delete a Marker (undo)	Delete
Freeze Video Image	ALT + F1
Get Image	ALT + F3
Next Overlay	Page Down
Overlay of Markers On/Off	F12

<b>ACTION (OPS) COMMAND</b>	<b>KEY</b>
Overlay, Go to #	Scroll Lock
Positioning Marker or Cursor	Arrow Keys
Positioning Marker, Fine Control	CTRL + Arrow Key
Previous Overlay	Page Up
Print Image	ALT + F4
Recall Settings (at copyright screen)	CTRL + ALT + Page Down(on Num Pad)
Reverse Toggle Order	Shift + Function Key
Save Image	ALT + F2
Save Settings (at copyright screen)	CTRL + ALT + Enter(on Num Pad)
Select	Enter
Send Image	ALT + F5
Menu System	Print Screen
Video In Composite	CTRL + F11
Video In Y/C	CTRL + F12



## Quick Reference for Touch Screens and Whiteboards

The commands in this table are for a compatible touch screen or whiteboard, when used with the Audio Presenter HUB. If a function you want is not listed in this table, then you must select that function in the menu system.

MARKING COMMAND	KEY
Anchor a Marker	Quickly tap screen where you want the marker anchored.
Clear Markers	Tap lower left corner. All markers are cleared from the screen.
Color, Change	Tap top left corner. The marker color is changed to the next color activated in the Color Palette.
Draw	Press and drag finger.
Freeze Video	Tap top-right corner. A frame of running video is grabbed and displayed. Tap same spot again to return to video.
Point	Lightly drag finger across the drawable area to position pointer. To keep pointer positionable, do not tap or press.
Print Screen Image	Tap the right-center area on the screen. The current image is sent to the printer.
Save Screen Image	Tap the left-center area on the screen. The current image is saved to the USB storage device.
Send Screen Image	Tap the bottom-center area on the screen. The current image is sent to the printer.
Undo/Erase Marker	Tap upper right corner. Activates either undo or erase command, depending on which mode has been chosen in the menu system.
Menu System, Access	Tap top center area. menu system is activated. (Operational only when keyboard not installed.)

## Symbol Font Chart

→ ← ↑ ↓ ↖ ↗ ↘ ↙ ⇨ ⇩ ⇧ ⇩  
a b c d e f g h i j k l

↩ ↪ ↪ ↩ ↪ ↩ ↪ ↩ ↪ ↩ ↪ ↩ ↪  
m n o p q r s t u v w x

○ ◦ ⇄ ⇄ ⇄ ⇄ ⇄ ⇄ ⇄ ⇄ ⇄ ⇄ ⇄ ⇄  
y z A B C D E F G H I J

⬆ ⬇ ⬇ ⬆ ⬆ ⬆ ⬆ ⬆ ⬆ ⬆ ⬆ ⬆ ⬆  
K L M N O P Q R S T U V

⬆ ⬆ ⬆ ⬆  
W X Y Z

🇺🇸 ① ② ③ ④ ⑤ ⑥ ⑦ ⑧ ⑨ ⑩  
> 1 2 3 4 5 6 7 8 9 0

↶ ↷ ↶ ↷ ↶ ↷ ↶ ↷ ↶ ↷ ↶ ↷  
- = [ ] \ ; ' , . /

⇧ ♂ ☑ ☎ 📄 ✍ ✎ ✉ ✎ ✎  
~ ! @ # \$ % ^ & \* ( )

🇺🇸 🇺🇸 ⬆ ⇨ ⇩ ⇨ ⇩ ♀ ⬆ ⬇  
+ { } | ~ " < > ?

## Map Font Chart

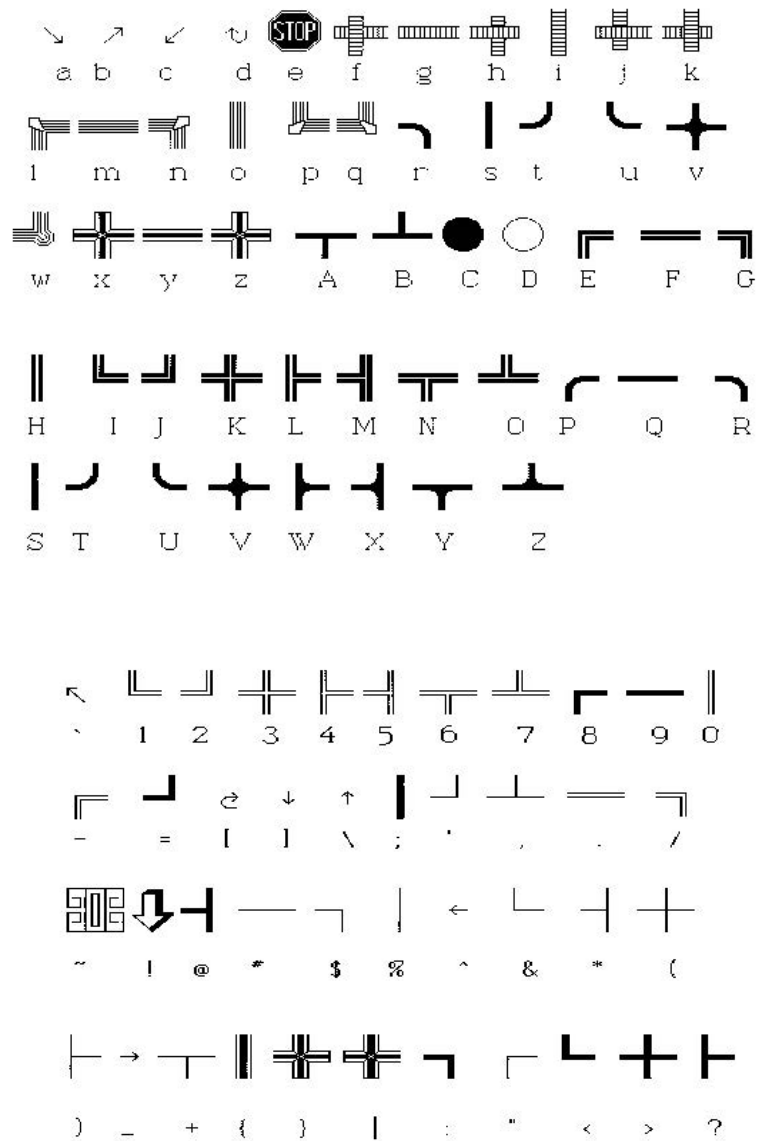

## RS-232 (COMM Port) Pinout and Commands

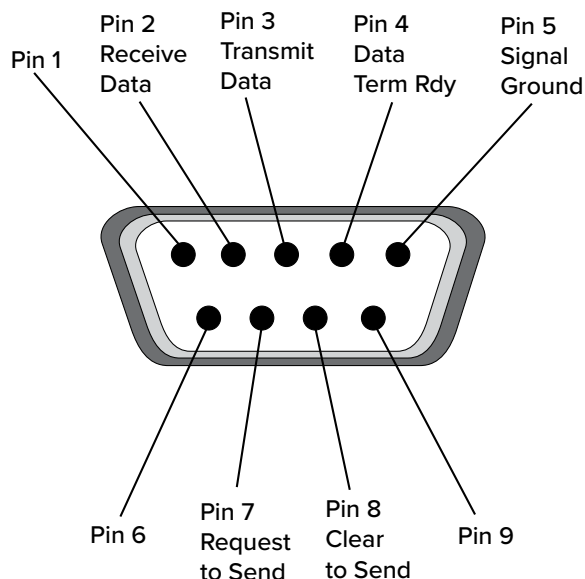

**RS-232 COMM Port Pinout**

Commands from third-party devices are sent via the RS-232 port. For a list of these commands, please read the Programmer's Guide, available on the Williams AV website.

## Outside copyright information for software included with the Audio Presenter HUB

(1) University of California, Berkeley

[1a]

Copyright (c) 1990 The Regents of the University of California.

All rights reserved.

Redistribution and use in source and binary forms are permitted provided that the above copyright notice and this paragraph are duplicated in all such forms and that any documentation, and other materials related to such distribution and use acknowledge that the software was developed by the University of California, Berkeley. The name of the University may not be used to endorse or promote products derived from this software without specific prior written permission.

THIS SOFTWARE IS PROVIDED "AS IS" AND WITHOUT ANY EXPRESS OR IMPLIED WARRANTIES, INCLUDING, WITHOUT LIMITATION, THE IMPLIED WARRANTIES OF MERCHANTABILITY AND FITNESS FOR A PARTICULAR PURPOSE.

[1b]

Copyright (c) 1990 The Regents of the University of California.

All rights reserved.

Redistribution and use in source and binary forms are permitted provided that the above copyright notice and this paragraph are duplicated in all such forms and that any documentation, advertising materials, and other materials related to such distribution and use acknowledge that the software was developed by the University of California, Berkeley. The name of the University may not be used to endorse or promote products derived from this software without specific prior written permission.

THIS SOFTWARE IS PROVIDED "AS IS" AND WITHOUT ANY EXPRESS OR IMPLIED WARRANTIES, INCLUDING, WITHOUT LIMITATION, THE IMPLIED WARRANTIES OF MERCHANTABILITY AND FITNESS FOR A PARTICULAR PURPOSE.

[1c]

Copyright (c) 1981, 1983, 1986, 1988, 1989, 1991, 1992, 1993, 1994

The Regents of the University of California.

All rights reserved.

Redistribution and use in source and binary forms, with or without modification, are permitted provided that the following conditions are met:

1. Redistributions of source code must retain the above copyright notice, this list of conditions and the following disclaimer.
2. Redistributions in binary form must reproduce the above copyright notice, this list of conditions and the following disclaimer in the documentation and/or other materials provided with the distribution.
3. Neither the name of the University nor the names of its contributors may be used to endorse or promote products derived from this software without specific prior written permission.

THIS SOFTWARE IS PROVIDED BY THE REGENTS AND CONTRIBUTORS "AS IS" AND ANY EXPRESS OR IMPLIED WARRANTIES, INCLUDING, BUT NOT LIMITED TO, THE IMPLIED WARRANTIES OF MERCHANTABILITY AND FITNESS FOR A PARTICULAR PURPOSE ARE DISCLAIMED. IN NO EVENT SHALL THE REGENTS OR CONTRIBUTORS BE LIABLE

FOR ANY DIRECT, INDIRECT, INCIDENTAL, SPECIAL, EXEMPLARY, OR CONSEQUENTIAL DAMAGES (INCLUDING, BUT NOT LIMITED TO, PROCUREMENT OF SUBSTITUTE GOODS OR SERVICES; LOSS OF USE, DATA, OR PROFITS; OR BUSINESS INTERRUPTION) HOWEVER CAUSED AND ON ANY THEORY OF LIABILITY, WHETHER IN CONTRACT, STRICT

LIABILITY, OR TORT (INCLUDING NEGLIGENCE OR OTHERWISE) ARISING IN ANY WAY OUT OF THE USE OF THIS SOFTWARE, EVEN IF ADVISED OF THE POSSIBILITY OF SUCH DAMAGE.

[1d]

Copyright (c) 1988, 1990, 1993 Regents of the University of California.

All rights reserved.

Redistribution and use in source and binary forms, with or without modification, are permitted provided that the following conditions are met:

1. Redistributions of source code must retain the above copyright notice, this list of conditions and the following disclaimer.
2. Redistributions in binary form must reproduce the above copyright notice, this list of conditions and the following disclaimer in the documentation and/or other materials provided with the distribution.
3. Neither the name of the University nor the names of its contributors may be used to endorse or promote products derived from this software without specific prior written permission.

THIS SOFTWARE IS PROVIDED BY THE REGENTS AND CONTRIBUTORS "AS IS" AND ANY EXPRESS OR IMPLIED WARRANTIES, INCLUDING, BUT NOT LIMITED TO, THE IMPLIED WARRANTIES OF MERCHANTABILITY AND FITNESS FOR A PARTICULAR PURPOSE ARE DISCLAIMED. IN NO EVENT SHALL THE REGENTS OR CONTRIBUTORS BE LIABLE FOR ANY DIRECT, INDIRECT, INCIDENTAL, SPECIAL, EXEMPLARY, OR CONSEQUENTIAL DAMAGES (INCLUDING, BUT NOT LIMITED TO, PROCUREMENT OF SUBSTITUTE GOODS OR SERVICES; LOSS OF USE, DATA, OR PROFITS; OR BUSINESS INTERRUPTION) HOWEVER CAUSED AND ON ANY THEORY OF LIABILITY, WHETHER IN CONTRACT, STRICT LIABILITY, OR TORT (INCLUDING NEGLIGENCE OR OTHERWISE) ARISING IN ANY WAY OUT OF THE USE OF THIS SOFTWARE, EVEN IF ADVISED OF THE POSSIBILITY OF SUCH DAMAGE.

[1e]

Copyright (c) 1982, 1986, 1989, 1991, 1993, 1994

The Regents of the University of California. All rights reserved.

(c) UNIX System Laboratories, Inc.

All or some portions of this file are derived from material licensed to the University of California by American Telephone and Telegraph Co. or UNIX System Laboratories, Inc. and are reproduced herein with the permission of UNIX System Laboratories, Inc.

Redistribution and use in source and binary forms, with or without modification, are permitted provided that the following conditions are met:

1. Redistributions of source code must retain the above copyright notice, this list of conditions and the following disclaimer.
2. Redistributions in binary form must reproduce the above copyright notice, this list of conditions and the following disclaimer in the documentation and/or other materials provided with the distribution.
3. Neither the name of the University nor the names of its contributors may be used to endorse or promote products derived from this software without specific prior written permission.

THIS SOFTWARE IS PROVIDED BY THE REGENTS AND CONTRIBUTORS "AS IS" AND ANY EXPRESS OR IMPLIED WARRANTIES, INCLUDING, BUT NOT LIMITED TO, THE IMPLIED WARRANTIES OF MERCHANTABILITY AND FITNESS FOR A PARTICULAR PURPOSE ARE DISCLAIMED. IN NO EVENT SHALL THE REGENTS OR CONTRIBUTORS BE LIABLE

FOR ANY DIRECT, INDIRECT, INCIDENTAL, SPECIAL, EXEMPLARY, OR CONSEQUENTIAL DAMAGES (INCLUDING, BUT NOT LIMITED TO, PROCUREMENT OF SUBSTITUTE GOODS OR SERVICES; LOSS OF USE, DATA, OR PROFITS; OR BUSINESS INTERRUPTION) HOWEVER CAUSED AND ON ANY THEORY OF LIABILITY, WHETHER IN CONTRACT, STRICT

LIABILITY, OR TORT (INCLUDING NEGLIGENCE OR OTHERWISE) ARISING IN ANY WAY OUT OF THE USE OF THIS SOFTWARE, EVEN IF ADVISED OF THE POSSIBILITY OF SUCH DAMAGE.

[1f]

Copyright (c) 1987, 1988, 2000 Regents of the University of California.

All rights reserved.

Redistribution and use in source and binary forms are permitted provided that: (1) source distributions retain this entire copyright notice and comment, and (2) distributions including binaries display the following acknowledgement: "This product includes software developed by the University of California, Berkeley and its contributors" in the documentation or other materials provided with the distribution.

Neither the name of the University nor the names of its contributors may be used to endorse or promote products derived from this software without specific prior written permission.

THIS SOFTWARE IS PROVIDED "AS IS" AND WITHOUT ANY EXPRESS OR IMPLIED WARRANTIES, INCLUDING, WITHOUT LIMITATION, THE IMPLIED WARRANTIES OF MERCHANTABILITY AND FITNESS FOR A PARTICULAR PURPOSE.

(3) David M. Gay at AT&T

The author of this software is David M. Gay.

Copyright (c) 1991 by AT&T.

Permission to use, copy, modify, and distribute this software for any purpose without fee is hereby granted, provided that this entire notice is included in all copies of any software which is or includes a copy or modification of this software and in all copies of the supporting documentation for such software.

THIS SOFTWARE IS BEING PROVIDED "AS IS", WITHOUT ANY EXPRESS OR IMPLIED WARRANTY. IN PARTICULAR, NEITHER THE AUTHOR NOR AT&T MAKES ANY REPRESENTATION OR WARRANTY OF ANY KIND CONCERNING THE MERCHANTABILITY OF THIS SOFTWARE OR ITS FITNESS FOR ANY PARTICULAR PURPOSE.

(11) Christopher G. Demetriou

Copyright (c) 2001 Christopher G. Demetriou

All rights reserved.

Redistribution and use in source and binary forms, with or without modification, are permitted provided that the following conditions are met:

1. Redistributions of source code must retain the above copyright notice, this list of conditions and the following disclaimer.
2. Redistributions in binary form must reproduce the above copyright notice, this list of conditions and the following disclaimer in the documentation and/or other materials provided with the distribution.
3. The name of the author may not be used to endorse or promote products derived from this software without specific prior written permission.

THIS SOFTWARE IS PROVIDED BY THE AUTHOR "AS IS" AND ANY EXPRESS OR IMPLIED WARRANTIES, INCLUDING, BUT NOT LIMITED TO, THE IMPLIED WARRANTIES OF MERCHANTABILITY AND FITNESS FOR A PARTICULAR PURPOSE ARE DISCLAIMED. IN NO EVENT SHALL THE AUTHOR BE LIABLE FOR ANY DIRECT, INDIRECT, INCIDENTAL, SPECIAL, EXEMPLARY, OR CONSEQUENTIAL DAMAGES (INCLUDING, BUT NOT LIMITED TO, PROCUREMENT OF SUBSTITUTE GOODS OR SERVICES; LOSS OF USE, DATA, OR PROFITS; OR BUSINESS INTERRUPTION) HOWEVER CAUSED AND ON ANY THEORY OF LIABILITY, WHETHER IN CONTRACT, STRICT LIABILITY, OR TORT (INCLUDING NEGLIGENCE OR OTHERWISE) ARISING IN ANY WAY OUT OF THE USE OF THIS SOFTWARE, EVEN IF ADVISED OF THE POSSIBILITY OF SUCH DAMAGE.

(13) Royal Institute of Technology

Copyright (c) 1999 Kungliga Tekniska Högskolan  
(Royal Institute of Technology, Stockholm, Sweden).

All rights reserved.

Redistribution and use in source and binary forms, with or without modification, are permitted provided that the following conditions are met:

1. Redistributions of source code must retain the above copyright notice, this list of conditions and the following disclaimer.
2. Redistributions in binary form must reproduce the above copyright notice, this list of conditions and the following disclaimer in the documentation and/or other materials provided with the distribution.
3. Neither the name of KTH nor the names of its contributors may be used to endorse or promote products derived from this software without specific prior written permission.

THIS SOFTWARE IS PROVIDED BY KTH AND ITS CONTRIBUTORS "AS IS" AND ANY EXPRESS OR IMPLIED WARRANTIES, INCLUDING, BUT NOT LIMITED TO, THE IMPLIED WARRANTIES OF MERCHANTABILITY AND FITNESS FOR A PARTICULAR

PURPOSE ARE DISCLAIMED. IN NO EVENT SHALL KTH OR ITS CONTRIBUTORS BE LIABLE FOR ANY DIRECT, INDIRECT, INCIDENTAL, SPECIAL, EXEMPLARY, OR CONSEQUENTIAL DAMAGES (INCLUDING, BUT NOT LIMITED TO, PROCUREMENT OF SUBSTITUTE GOODS OR SERVICES; LOSS OF USE, DATA, OR PROFITS; OR BUSINESS INTERRUPTION) HOWEVER CAUSED AND ON ANY THEORY OF LIABILITY, WHETHER IN CONTRACT, STRICT LIABILITY, OR TORT (INCLUDING NEGLIGENCE OR OTHERWISE) ARISING IN ANY WAY OUT OF THE USE OF THIS SOFTWARE, EVEN IF ADVISED OF THE POSSIBILITY OF SUCH DAMAGE.

(14) Alexey Zelkin

Copyright (c) 2000, 2001 Alexey Zelkin <phantom@FreeBSD.org>

All rights reserved.

Redistribution and use in source and binary forms, with or without modification, are permitted provided that the following conditions are met:

1. Redistributions of source code must retain the above copyright notice, this list of conditions and the following disclaimer.
2. Redistributions in binary form must reproduce the above copyright notice, this list of conditions and the following disclaimer in the documentation and/or other materials provided with the distribution.

THIS SOFTWARE IS PROVIDED BY THE AUTHOR AND CONTRIBUTORS "AS IS" AND ANY EXPRESS OR IMPLIED WARRANTIES, INCLUDING, BUT NOT LIMITED TO, THE IMPLIED WARRANTIES OF MERCHANTABILITY AND FITNESS FOR A PARTICULAR PURPOSE ARE DISCLAIMED. IN NO EVENT SHALL THE AUTHOR OR CONTRIBUTORS BE LIABLE FOR ANY DIRECT, INDIRECT, INCIDENTAL, SPECIAL, EXEMPLARY, OR CONSEQUENTIAL DAMAGES (INCLUDING, BUT NOT LIMITED TO, PROCUREMENT OF SUBSTITUTE GOODS OR SERVICES; LOSS OF USE, DATA, OR PROFITS; OR BUSINESS INTERRUPTION) HOWEVER CAUSED AND ON ANY THEORY OF LIABILITY, WHETHER IN CONTRACT, STRICT LIABILITY, OR TORT (INCLUDING NEGLIGENCE OR OTHERWISE) ARISING IN ANY WAY OUT OF THE USE OF THIS SOFTWARE, EVEN IF ADVISED OF THE POSSIBILITY OF SUCH DAMAGE.

(15) Andrey A. Chernov

Copyright (C) 1997 by Andrey A. Chernov, Moscow, Russia.

All rights reserved.

Redistribution and use in source and binary forms, with or without modification, are permitted provided that the following conditions are met:

1. Redistributions of source code must retain the above copyright notice, this list of conditions and the following disclaimer.
2. Redistributions in binary form must reproduce the above copyright notice, this list of conditions and the following disclaimer in the documentation and/or other materials provided with the distribution.

THIS SOFTWARE IS PROVIDED BY THE AUTHOR "AS IS" AND ANY EXPRESS OR IMPLIED WARRANTIES, INCLUDING, BUT NOT LIMITED TO, THE IMPLIED WARRANTIES OF MERCHANTABILITY AND FITNESS FOR A PARTICULAR PURPOSE ARE DISCLAIMED. IN NO EVENT SHALL THE REGENTS OR CONTRIBUTORS BE LIABLE FOR ANY DIRECT, INDIRECT, INCIDENTAL, SPECIAL, EXEMPLARY, OR CONSEQUENTIAL DAMAGES (INCLUDING, BUT NOT LIMITED TO, PROCUREMENT OF SUBSTITUTE GOODS OR SERVICES; LOSS OF USE, DATA, OR PROFITS; OR BUSINESS INTERRUPTION) HOWEVER CAUSED AND ON ANY THEORY OF LIABILITY, WHETHER IN CONTRACT, STRICT LIABILITY, OR TORT (INCLUDING NEGLIGENCE OR OTHERWISE) ARISING IN ANY WAY OUT OF THE USE OF THIS SOFTWARE, EVEN IF ADVISED OF THE POSSIBILITY OF SUCH DAMAGE.

(16) FreeBSD

Copyright (c) 1997-2002 FreeBSD Project.

All rights reserved.

Redistribution and use in source and binary forms, with or without modification, are permitted provided that the following conditions are met:

1. Redistributions of source code must retain the above copyright notice, this list of conditions and the following disclaimer.
2. Redistributions in binary form must reproduce the above copyright notice, this list of conditions and the following disclaimer in the documentation and/or other materials provided with the distribution.

THIS SOFTWARE IS PROVIDED BY THE AUTHOR AND CONTRIBUTORS "AS IS" AND ANY EXPRESS OR IMPLIED WARRANTIES, INCLUDING, BUT NOT LIMITED TO, THE IMPLIED WARRANTIES OF MERCHANTABILITY AND FITNESS FOR A PARTICULAR PURPOSE ARE DISCLAIMED. IN NO EVENT SHALL THE AUTHOR OR CONTRIBUTORS BE LIABLE FOR ANY DIRECT, INDIRECT, INCIDENTAL, SPECIAL, EXEMPLARY, OR CONSEQUENTIAL DAMAGES (INCLUDING, BUT NOT LIMITED TO, PROCUREMENT OF SUBSTITUTE GOODS OR SERVICES; LOSS OF USE, DATA, OR PROFITS; OR BUSINESS INTERRUPTION) HOWEVER CAUSED AND ON ANY THEORY OF LIABILITY, WHETHER IN CONTRACT, STRICT LIABILITY, OR TORT (INCLUDING NEGLIGENCE OR OTHERWISE) ARISING IN ANY WAY OUT OF THE USE OF THIS SOFTWARE, EVEN IF ADVISED OF THE POSSIBILITY OF SUCH DAMAGE.

(17) S. L. Moshier

Author: S. L. Moshier.

Copyright (c) 1984,2000 S.L. Moshier

Permission to use, copy, modify, and distribute this software for any purpose without fee is hereby granted, provided that this entire notice is included in all copies of any software which is or includes a copy or modification of this software and in all copies of the supporting documentation for such software.

THIS SOFTWARE IS BEING PROVIDED "AS IS", WITHOUT ANY EXPRESS OR IMPLIED WARRANTY. IN PARTICULAR, THE AUTHOR MAKES NO REPRESENTATION OR WARRANTY OF ANY KIND CONCERNING THE MERCHANTABILITY OF THIS SOFTWARE OR ITS FITNESS FOR ANY PARTICULAR PURPOSE.

(18) Citrus Project

Copyright (c)1999 Citrus Project,  
All rights reserved.

Redistribution and use in source and binary forms, with or without modification, are permitted provided that the following conditions are met:

1. Redistributions of source code must retain the above copyright notice, this list of conditions and the following disclaimer.
2. Redistributions in binary form must reproduce the above copyright notice, this list of conditions and the following disclaimer in the documentation and/or other materials provided with the distribution.

THIS SOFTWARE IS PROVIDED BY THE AUTHOR AND CONTRIBUTORS "AS IS" AND ANY EXPRESS OR IMPLIED WARRANTIES, INCLUDING, BUT NOT LIMITED TO, THE IMPLIED WARRANTIES OF MERCHANTABILITY AND FITNESS FOR A PARTICULAR PURPOSE ARE DISCLAIMED. IN NO EVENT SHALL THE AUTHOR OR CONTRIBUTORS BE LIABLE

FOR ANY DIRECT, INDIRECT, INCIDENTAL, SPECIAL, EXEMPLARY, OR CONSEQUENTIAL DAMAGES (INCLUDING, BUT NOT LIMITED TO, PROCUREMENT OF SUBSTITUTE GOODS OR SERVICES; LOSS OF USE, DATA, OR PROFITS; OR BUSINESS INTERRUPTION) HOWEVER CAUSED AND ON ANY THEORY OF LIABILITY, WHETHER IN CONTRACT, STRICT

LIABILITY, OR TORT (INCLUDING NEGLIGENCE OR OTHERWISE) ARISING IN ANY WAY OUT OF THE USE OF THIS SOFTWARE, EVEN IF ADVISED OF THE POSSIBILITY OF SUCH DAMAGE.

(19) Todd C. Miller

Copyright (c) 1998 Todd C. Miller <Todd.Miller@courtesan.com>  
All rights reserved.

Redistribution and use in source and binary forms, with or without modification, are permitted provided that the following conditions are met:

1. Redistributions of source code must retain the above copyright notice, this list of conditions and the following disclaimer.
2. Redistributions in binary form must reproduce the above copyright notice, this list of conditions and the following disclaimer in the documentation and/or other materials provided with the distribution.
3. The name of the author may not be used to endorse or promote products derived from this software without specific prior written permission.

THIS SOFTWARE IS PROVIDED "AS IS" AND ANY EXPRESS OR IMPLIED WARRANTIES, INCLUDING, BUT NOT LIMITED TO, THE IMPLIED WARRANTIES OF MERCHANTABILITY AND FITNESS FOR A PARTICULAR PURPOSE ARE DISCLAIMED. IN NO EVENT SHALL THE AUTHOR BE LIABLE FOR ANY DIRECT, INDIRECT, INCIDENTAL, SPECIAL, EXEMPLARY, OR CONSEQUENTIAL DAMAGES (INCLUDING, BUT NOT LIMITED TO, PROCUREMENT OF SUBSTITUTE GOODS OR SERVICES; LOSS OF USE, DATA, OR PROFITS; OR BUSINESS INTERRUPTION) HOWEVER CAUSED AND ON ANY THEORY OF LIABILITY, WHETHER IN CONTRACT, STRICT LIABILITY, OR TORT (INCLUDING NEGLIGENCE OR OTHERWISE) ARISING IN ANY WAY OUT OF THE USE OF THIS SOFTWARE, EVEN IF ADVISED OF THE POSSIBILITY OF SUCH DAMAGE.

(26) Mike Barcroft

Copyright (c) 2001 Mike Barcroft <mike@FreeBSD.org>  
All rights reserved.

Redistribution and use in source and binary forms, with or without modification, are permitted provided that the following conditions are met:

1. Redistributions of source code must retain the above copyright notice, this list of conditions and the following disclaimer.



2. Redistributions in binary form must reproduce the above copyright notice, this list of conditions and the following disclaimer in the documentation and/or other materials provided with the distribution.

THIS SOFTWARE IS PROVIDED BY THE AUTHOR AND CONTRIBUTORS "AS IS" AND ANY EXPRESS OR IMPLIED WARRANTIES, INCLUDING, BUT NOT LIMITED TO, THE IMPLIED WARRANTIES OF MERCHANTABILITY AND FITNESS FOR A PARTICULAR PURPOSE ARE DISCLAIMED. IN NO EVENT SHALL THE AUTHOR OR CONTRIBUTORS BE LIABLE FOR ANY DIRECT, INDIRECT, INCIDENTAL, SPECIAL, EXEMPLARY, OR CONSEQUENTIAL DAMAGES (INCLUDING, BUT NOT LIMITED TO, PROCUREMENT OF SUBSTITUTE GOODS OR SERVICES; LOSS OF USE, DATA, OR PROFITS; OR BUSINESS INTERRUPTION) HOWEVER CAUSED AND ON ANY THEORY OF LIABILITY, WHETHER IN CONTRACT, STRICT LIABILITY, OR TORT (INCLUDING NEGLIGENCE OR OTHERWISE) ARISING IN ANY WAY OUT OF THE USE OF THIS SOFTWARE, EVEN IF ADVISED OF THE POSSIBILITY OF SUCH DAMAGE.

(28) Red Hat Incorporated

Unless otherwise stated in each remaining newlib file, the remaining files in the newlib subdirectory default to the following copyright. It should be noted that Red Hat Incorporated now owns copyrights belonging to Cygnus Solutions and Cygnus Support.

Copyright (c) 1994, 1997, 2001, 2002, 2003, 2004 Red Hat Incorporated.

All rights reserved.

Redistribution and use in source and binary forms, with or without modification, are permitted provided that the following conditions are met:

Redistributions of source code must retain the above copyright notice, this list of conditions and the following disclaimer.

Redistributions in binary form must reproduce the above copyright notice, this list of conditions and the following disclaimer in the documentation and/or other materials provided with the distribution.

The name of Red Hat Incorporated may not be used to endorse or promote products derived from this software without specific prior written permission.

THIS SOFTWARE IS PROVIDED BY THE COPYRIGHT HOLDERS AND CONTRIBUTORS "AS IS" AND ANY EXPRESS OR IMPLIED WARRANTIES, INCLUDING, BUT NOT LIMITED TO, THE IMPLIED WARRANTIES OF MERCHANTABILITY AND FITNESS FOR A PARTICULAR PURPOSE ARE DISCLAIMED. IN NO EVENT SHALL RED HAT INCORPORATED BE LIABLE FOR ANY DIRECT, INDIRECT, INCIDENTAL, SPECIAL, EXEMPLARY, OR CONSEQUENTIAL DAMAGES (INCLUDING, BUT NOT LIMITED TO, PROCUREMENT OF SUBSTITUTE GOODS OR SERVICES; LOSS OF USE, DATA, OR PROFITS; OR BUSINESS INTERRUPTION) HOWEVER CAUSED AND ON ANY THEORY OF LIABILITY, WHETHER IN CONTRACT, STRICT LIABILITY, OR TORT (INCLUDING NEGLIGENCE OR OTHERWISE) ARISING IN ANY WAY OUT OF THE USE OF THIS SOFTWARE, EVEN IF ADVISED OF THE POSSIBILITY OF SUCH DAMAGE.

Copyright (c) 2001, 2002 Swedish Institute of Computer Science.

All rights reserved.

Redistribution and use in source and binary forms, with or without modification, are permitted provided that the following conditions are met:

1. Redistributions of source code must retain the above copyright notice, this list of conditions and the following disclaimer.

2. Redistributions in binary form must reproduce the above copyright notice, this list of conditions and the following disclaimer in the documentation and/or other materials provided with the distribution.

3. The name of the author may not be used to endorse or promote products derived from this software without specific prior written permission.

THIS SOFTWARE IS PROVIDED BY THE AUTHOR "AS IS" AND ANY EXPRESS OR IMPLIED WARRANTIES, INCLUDING, BUT NOT LIMITED TO, THE IMPLIED WARRANTIES OF MERCHANTABILITY AND FITNESS FOR A PARTICULAR PURPOSE ARE DISCLAIMED. IN NO EVENT SHALL THE AUTHOR BE LIABLE FOR ANY DIRECT, INDIRECT, INCIDENTAL, SPECIAL, EXEMPLARY, OR CONSEQUENTIAL DAMAGES (INCLUDING, BUT NOT LIMITED TO, PROCUREMENT OF SUBSTITUTE GOODS OR SERVICES; LOSS OF USE, DATA, OR PROFITS; OR BUSINESS INTERRUPTION) HOWEVER CAUSED AND ON ANY THEORY OF LIABILITY, WHETHER IN CONTRACT, STRICT LIABILITY, OR TORT (INCLUDING NEGLIGENCE OR OTHERWISE) ARISING IN ANY WAY OUT OF THE USE OF THIS SOFTWARE, EVEN IF ADVISED OF THE POSSIBILITY OF SUCH DAMAGE.

This file is part of the lwIP TCP/IP stack.

Author: Adam Dunkels <adam@sics.se>

## Specifications

### Audio Presenter HUB

<b>Dimensions</b>	1 RU - 19" (W) x 1.75" (H) x 7.625" (D) (48.26 cm x 4.45 cm x 19.37 cm)
<b>Weight</b>	5.4 lbs. (2.45 kg)
<b>Power Supply</b>	TFP 059 – 100-240VAC 50/60Hz Input
<b>Power Source</b>	24VDC, 6.7A, Center Positive
<b>Power Indicator</b>	Green LED
<b>Network</b>	LAN port for printing/saving still images and third-party remote control. Audio/Video streaming in and out. H.264 and H.265 compatible.
<b>USB</b>	(5) USB 3.0 ports, plus (1) USB B-Micro port
<b>Operating Temperature</b>	32°F to 122°F (0°C to 50°C)
<b>Comm Ports</b>	2
<b>Approvals</b>	CE, FCC, Industry Canada, WEEE, RoHS, CB Scheme, RCM, PSE

## Regulatory Statements



Caution: Unauthorized modifications or changes not expressly approved by Williams AV could void compliance with regulatory rules, and thereby your authority to use this equipment.



Caution: A 20 CM separation distance must be maintained between the Bluetooth Wireless Access Point's Bluetooth antenna and the user's body at all times.

### United States - FCC

*This device complies with Part 15 of the FCC Rules. Operation is subject to the following two conditions: (1) this device may not cause harmful interference, and (2) this device must accept any interference received, including interference that may cause undesired operation.*

### Canada IC

*This device complies with Industry Canada license-exempt RSS standard(s). Operation is subject to the following two conditions: (1) this device may not cause harmful interference, and (2) this device must accept any interference received, including interference that may cause undesired operation.*

*Le présent appareil est conforme aux CNR d'Industrie Canada applicables aux appareils radio exempts de licence. L'exploitation est autorisée aux deux conditions suivantes: (1) l'appareil ne doit pas produire de brouillage, et (2) l'utilisateur de l'appareil doit accepter tout brouillage radioélectrique subi, même si le brouillage est susceptible d'en compromettre le fonctionnement.*

## Japanese Regulatory Standards



この装置は、クラスA機器です。この装置を住宅環境で使用すると電波妨害を引き起こすことがあります。この場合には使用者が適切な対策を講ずるよう要求されることがあります。VCCI-A

This is a Class A equipment. Operation of this equipment in a residential environment could cause radio interference. In such a case, the user may be required to take corrective actions. VCCI-A



**R** 007-AG0141 **R** 006-000353

## Limited Warranty

---

Williams AV products are engineered, designed, and manufactured under carefully controlled conditions to provide many years of reliable service. Williams AV warrants the Audio Presenter HUB against defects in materials and workmanship for two (2) years. During the first two years from the purchase date, we will promptly repair or replace the Audio Presenter HUB system.

Microphones, earphones, headphones, batteries, chargers, cables, carry cases, and all other accessory products carry a 90-day warranty.

WILLIAMS AV HAS NO CONTROL OVER THE CONDITIONS UNDER WHICH THIS PRODUCT IS USED. WILLIAMS AV, THEREFORE, DISCLAIMS ALL WARRANTIES NOT SET FORTH ABOVE, BOTH EXPRESS AND IMPLIED, WITH RESPECT TO THE AUDIO PRESENTER HUB SYSTEM, INCLUDING BUT NOT LIMITED TO, ANY IMPLIED WARRANTY OF MERCHANTABILITY OR FITNESS FOR A PARTICULAR PURPOSE. WILLIAMS AV SHALL NOT BE LIABLE TO ANY PERSON OR ENTITY FOR ANY MEDICAL EXPENSES OR ANY DIRECT, INCIDENTAL OR CONSEQUENTIAL DAMAGES CAUSED BY ANY USE, DEFECT, FAILURE OR MALFUNCTIONING OF THE PRODUCT, WHETHER A CLAIM FOR SUCH DAMAGES IS BASED UPON WARRANTY, CONTRACT, TORT OR OTHERWISE, THE SOLE REMEDY FOR ANY DEFECT, FAILURE OR MALFUNCTION OF THE PRODUCTS REPLACEMENT OF THE PRODUCT. NO PERSON HAS ANY AUTHORITY TO BIND WILLIAMS AV TO ANY REPRESENTATION OR WARRANTY WITH RESPECT TO THE AUDIO PRESENTER HUB SYSTEM. UNAUTHORIZED REPAIRS OR MODIFICATIONS WILL VOID THE WARRANTY.

The exclusions and limitations set out above are not intended to, and should not be construed so as to contravene mandatory provisions of applicable law. If any part or term of this Disclaimer of Warranty is held to be illegal, unenforceable, or in conflict with applicable law by a court of competent jurisdiction, the validity of the remaining portions of this Disclaimer of Warranty shall not be affected, and all rights and obligations shall be construed and enforced as if this Limited Warranty did not contain the particular part or term held to be invalid.

If you experience difficulty with your system, call toll-free for customer assistance: **1-800-843-3544 (U.S.A.) or +1 952 943 2252** (outside the U.S.A.)

If it is necessary to return the system for service, your Customer Service Representative will give you a Return Authorization Number (RA) and shipping instructions.

Pack the system carefully and send it to:

**Williams AV**

**Attn: Repair Dept.**

**10300 Valley View Road**

**Eden Prairie, MN 55344 USA**

Your warranty becomes effective the date you purchase your system. If your sales receipt is not available, the date code on the product will determine your warranty status.

**WILLIAMS AV**

[info@williamsav.com](mailto:info@williamsav.com) / [www.williamsav.com](http://www.williamsav.com)  
800-843-3544 / INTL: +1-952-943-2252