

# 7<sup>TM</sup> FLURRY L



Blizzard Lighting, LLC  
<http://www.blizzardpro.com>  
Waukesha, WI USA  
Copyright (c) 2019

# TABLE OF CONTENTS

Flurry™ Z	1
<b>1. Getting Started</b>	<b>3</b>
What's In The Box?	3
Getting It Out Of The Box	3
Powering Up!	3
Getting A Hold Of Us	3
Safety Instructions (Don't Stick Your Hand In The Toaster!)	4
<b>2. Meet The Flurry™ Z</b>	<b>5</b>
Main Features	5
DMX Quick Reference	5
The Flurry™ Z Pin-up Picture	6
<b>3. Setup</b>	<b>7</b>
Fuse Replacement	7
Connecting A Bunch Of Flurry™ Z Fixtures	7
Data/DMX Cables	7
Cable Connectors	8
3-pin??? 5-Pin??? Huh?	8
Take It To The Next Level: Setting up DMX Control	8
Fixture Linking (Master/Slave Mode)	9
Clamp Mounting	9
Securing the Fixture	9
Mounting Points	10
<b>4. Operating Adjustments</b>	<b>12</b>
The Control Panel	12
Control Panel Menu Structure	12
DMX Mode	12
Select the DMX Starting Address	12
Select the Channel Mode	12
Select the DMX Run Mode	12
Master/Slave Mode Settings	12
Auto and Sound Active Modes	12
DMX Channel Values In-Depth	13
<b>5. Appendix</b>	<b>14</b>
Keeping Your Flurry™ Z As Good As New	14
Returns (Gasp!)	14
Shipping Issues	14
Dimensional Drawings	14
Tech Specs	15

# 1. GETTING STARTED

## What's In The Box?

- Flurry™ Z
- An Ever-So-Handy Power Cord
- A Set of Mounting Brackets
- This Lovely User Manual

## Getting It Out Of The Box

Congratulations on purchasing the Flurry™ Z moving head fixture! Now that you've got your Flurry™ Z, you should carefully unpack the box and check the contents to ensure that all parts are present and in good condition. If anything looks as if it has been damaged in transit, notify the shipper immediately and keep the packing material for inspection. Again, please save the carton and all packing materials. If a fixture must be returned to the factory, it is important that the fixture be returned in the original factory box and packing.

## Powering Up!

All fixtures must be powered directly off a switched circuit and **cannot be run off a rheostat (variable resistor) or dimmer circuit, even if the rheostat or dimmer channel is used solely for a 0% to 100% switch.**

*AC Voltage Switch* - Not all fixtures have a voltage select switch, so please verify that the fixture you receive is suitable for your local power supply. See the label on the fixture or refer to the fixture's specifications chart for more information. A fixture's listed current rating is its average current draw under normal conditions. Check the fixture or device carefully to make sure that if a voltage selection switch exists that it is set to the correct line voltage you will use.

**Warning! Verify that the voltage select switch on your unit matches the line voltage applied. Damage to your fixture may result if the line voltage applied does not match the voltage indicated on the voltage selector switch. All fixtures must be connected to circuits with a suitable Ground (Earthing).**

## Getting A Hold Of Us

**If something happens goes wrong, please visit [www.blizzardpro.com/support](http://www.blizzardpro.com/support) and open a support ticket. We'll be happy to help, honest.**

**Disclaimer:** The information and specifications contained in this document are subject to change without notice. Blizzard Lighting™ assumes no responsibility or liability for any errors or omissions that may appear in this user manual. Blizzard Lighting™ reserves the right to update the existing document or to create a new document to correct any errors or omissions at any time. You can download the latest version of this document from [www.blizzardpro.com](http://www.blizzardpro.com).

Author:	Date:	Last Edited:	Date:
J. Thomas	11/11/2019	J. Thomas	12/10/2019

# SAFETY INSTRUCTIONS



Please read these instructions carefully. They include important information about the installation, usage and maintenance of this product.

- Please keep this User Guide for future use. If you sell the unit to someone else, be sure that they also receive this User Guide.
- ALWAYS make sure that you are connecting to the proper voltage, and that the line voltage you are connecting to is not higher than that stated on the decal or rear panel of the fixture.
- This product is intended for indoor use only.
- To prevent risk of fire or shock, do not expose fixture to rain or moisture.
- Make sure there are no flammable materials close to the unit while operating.
- The unit must be installed in a location with adequate ventilation, at least 20in (50cm) from adjacent surfaces. Be sure that no ventilation slots are blocked.
- ALWAYS disconnect from the power source before servicing or replacing fuse and be sure to replace with same fuse size and type.
- ALWAYS secure fixture using a safety chain. NEVER carry the fixture by its head. Use its carrying handles.
- DO NOT operate at ambient temperatures higher than 104°F (40°C).
- In the event of a serious operating problem, stop using the unit immediately. NEVER try to repair the unit by yourself. Repairs carried out by unskilled people can lead to damage or malfunction. Please contact the nearest authorized technical assistance center. Always use the same type spare parts.
- NEVER connect the device to a dimmer pack.
- Make sure the power cord is never crimped or damaged.
- Never disconnect the power cord by pulling or tugging on the cord.
- Avoid direct eye exposure to the light source while it is on.

**Caution!** There are no user serviceable parts inside the unit. Do not open the housing or attempt any repairs yourself. In the unlikely event your unit may require service, please open a support ticket at [www.blizzardpro.com/support](http://www.blizzardpro.com/support).

# 2. MEET THE FLURRY™ Z

## MAIN FEATURES

- 19\* 15W ultra-bright 4-in-1 RGBW LEDs
- Pan: 540°/ Tilt: 280° (8-16 Bit Resolution)
- 3-zone LED ring effects + 5 to 50-degree motorized zoom
- 16 static color presets, 10 built-in color chase macros
- 0% - 100% electronic dimming
- Fast pan/tilt + optional invert for contrasting movements
- Built-in auto and sound active programs
- Fast fade & smooth fade dimming profiles
- Internal fan cooling system
- PowerCON® compatible power input/output connections
- Dual omega brackets with 1/4-turn fasteners

## CONTROL

- Protocol: USITT DMX-512
- DMX channels: 8/15/23-channel modes
- Easy-to-use 4-button control panel with LCD display
- Operating modes: DMX512, master/slave, auto, sound active

### DMX Quick Reference (8/15/23-Channel Modes)

8CH	15CH	23CH	What It Does
1	1	1	Pan
--	2	2	Fine Pan (16-bit)
2	3	3	Tilt
--	4	4	Fine Tilt (16-bit)
--	5	5	Pan/Tilt Speed (fast <-> slow)
3	6	6	Zoom (wide <-> narrow)
4	7	7	Dimmer
--	8	8	Strobe (slow <-> fast)
--	9	9	Color Macros
--	10	10	Color Macro Speed (fast <-> slow)
5	11	--	Red Intensity
6	12	--	Green Intensity
7	13	--	Blue Intensity
8	14	--	White Intensity
--	--	11	Inside Red
--	--	12	Inside Green
--	--	13	Inside Blue
--	--	14	Inside White
--	--	15	Middle Red
--	--	16	Middle Green
--	--	17	Middle Blue
--	--	18	Middle White
--	--	19	Outside Red
--	--	20	Outside Green
--	--	21	Outside Blue
--	--	22	Outside White
--	15	23	Reset

**Figure 1: The Flurry™ Z Pin-Up Picture**



**Figure 2: The Rear Connections**

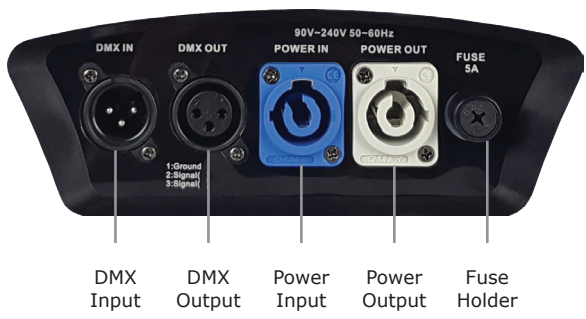

### 3. SETUP



Before replacing the fuse, disconnect the power cord.  
ALWAYS replace it with the same type and rating.

#### **Fuse Replacement**

Disconnect the power and remove the unit's power cord. Once the cord has been removed locate the fuse holder that is located next to the power input/output connections. Using a phillips head screwdriver, unscrew the fuse holder. Remove the bad fuse and replace with a new one, then screw the fuse holder back into place.

#### **Connecting A Bunch of Flurry™ Z Fixtures**

You will need a serial data link to run light shows using a DMX-512 controller or to run shows on two or more fixtures set to sync in master/slave operating mode. The combined number of channels required by all the fixtures on a serial data link determines the number of fixtures the data link can support.

Fixtures on a serial data link must be daisy chained in one single line. Also, connecting more than 32 fixtures on one serial data link without the use of a DMX optically-isolated splitter may result in deterioration of the digital DMX signal.

The maximum recommended cable-run distance is 500 meters (1640 ft). The maximum recommended number of fixtures on a serial data link is 32 fixtures.

#### **Data/DMX Cabling**

To link fixtures together you'll need data cables.

You should use data-grade cables that can carry a high quality signal and are less prone to electromagnetic interference.

For instance, Belden© 9841 meets the specifications for EIA RS-485 applications. Standard microphone cables will "probably" be OK, but note that they cannot transmit DMX data as reliably over long distances. In any event, the cable should have the following characteristics:

- 2-conductor twisted pair plus a shield
- Maximum capacitance between conductors – 30 pF/ft.
- Maximum capacitance between conductor & shield – 55 pF/ft.
- Maximum resistance of 20 ohms / 1000 ft.
- Nominal impedance 100 – 140 ohms

For longer cable runs, it is a good idea to have a DMX terminator plug inserted into the female XLR (DMX output) connector of the last unit. This will properly terminate the data signal, greatly decreasing the possibility of erratic behavior.

## Cable Connectors

Cables must have a male XLR connector on one end and a female XLR connector on the other end. (Duh!)

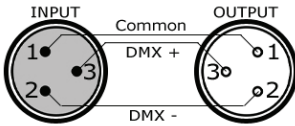

**A Word on Termination:** DMX is a resilient communication protocol, however errors still occasionally occur. Termination reduces signal errors, and therefore best practices include use of a terminator in all circumstances. If you are experiencing problems with erratic fixture behavior, especially over long signal cable runs, a terminator may help improve performance.

**To build your own DMX Terminator:**  
Obtain a 120-ohm, 1/4-watt resistor, and wire it between pins 2 & 3 of the last fixture. They are also readily available from specialty retailers.

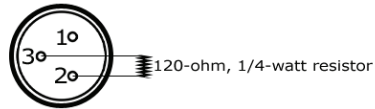

**CAUTION:** Do not allow contact between the common and the fixture's chassis ground. Grounding the common can cause a ground loop, and your fixture may perform erratically. Test cables with an ohm meter to verify correct polarity and to make sure the pins are not grounded or shorted to the shield or each other.

### 3-pin??? 5-Pin??? Huh?!?

If you use a controller with only a 5-pin DMX output connector, you will need to use a 5-pin to 3-pin adapter. They are widely available over the internet and from specialty retailers. If you'd like to build your own, the chart below details a proper cable conversion:

Conductor	3-pin Female (Output)	5-Pin Male (Input)
Ground/Shield	Pin 1	Pin 1
Data 1- (Primary Data Link)	Pin 2	Pin 2
Data 1+ (Primary Data Link)	Pin 3	Pin 3
Data 2- (Optional Secondary Data Link)	n/c	n/c
Data 2+ (Optional Secondary Data Link)	n/c	n/c

## Take It To The Next Level: Setting Up DMX Control

**Step 1:** Connect the male connector of the DMX cable to the female connector (output) of the controller.

**Step 2:** Connect the female connector of the DMX cable to the first fixture's male connector (input). *Note:* It doesn't matter which fixture address is the first one connected. We recommend connecting the fixtures in terms of their proximity to the controller, rather than connecting the lowest fixture number first, and so on.

**Step 3:** Connect other fixtures in the chain from output to input as above. Place a DMX terminator on the output of the final fixture to ensure best communication.

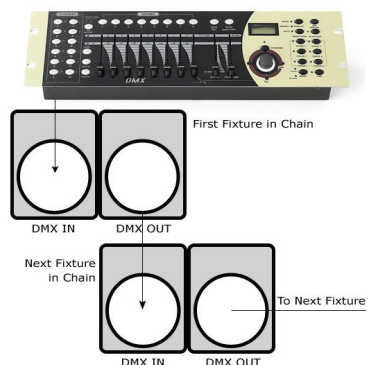



## Fixture Linking (Master/Slave Mode)

1. Connect the (male) 3-pin connector side of the DMX cable to the output (female) 3-pin connector of the first fixture.
2. Connect the end of the cable coming from the first fixture which will have a (female) 3-pin connector to the input connector of the next fixture consisting of a (male) 3-pin connector. Then, proceed to connect from the output as stated above to the input of the following fixture and so on.

## Clamp Mounting

This fixture provides a mounting bracket assembly that secures the bottom of the base, the "Omega Brackets," and the safety cable rigging point together. When mounting this fixture to truss, be sure to secure an appropriately rated clamp to the omega bracket.

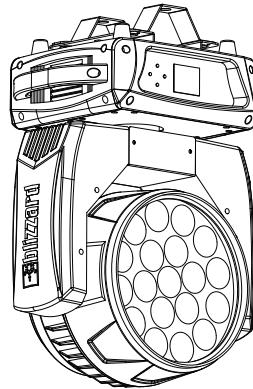
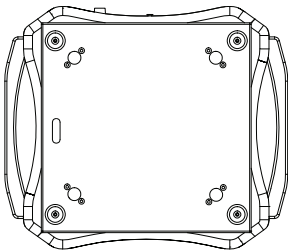

- 1.) Clamp
- 2.) Omega Bracket
- 3.) 1/4 Turn Quick Lock Fasteners

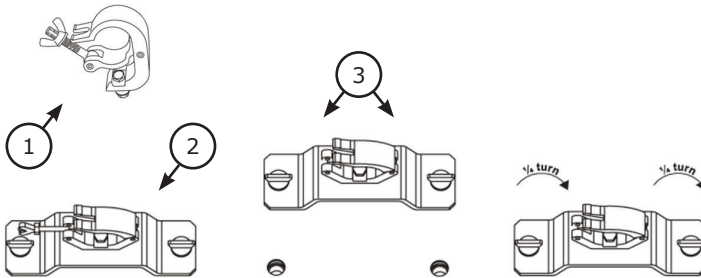

## Securing the Fixture

Regardless of the rigging option you choose for your fixtures always be sure to secure your fixture with a safety cable. Be sure to only use the designated rigging point found on the underside of the base assembly for the safety cable. Never secure a safety cable to a carrying handle.

## Mounting Points

Overhead mounting requires extensive experience, which includes calculating working load limits, knowledge of the installation material being used, and periodic safety inspection of all installation material and the fixture. If you lack these qualifications, do not attempt the installation yourself. Improper installation can result in bodily injury.

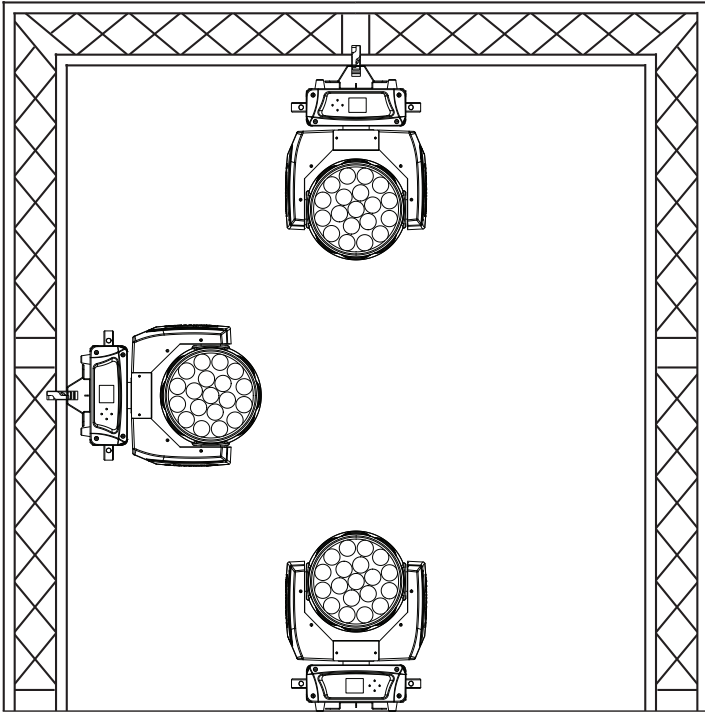

### Caution!

Please be aware, you should have a qualified electrician performing all of your electrical connection needs.

Be sure to complete all rigging and installation procedures before connecting the main power cord to the appropriate wall outlet.

# 4. OPERATING ADJUSTMENTS

## The Control Panel

All the goodies and different modes possible with the Flurry™ Z are accessed by using the control panel on the front of the fixture. There are 4 control buttons to the right of the LCD display which allow you to navigate through the various control panel menus.

### <MENU>

Is used to navigate to the previous higher-level menu item.

### <ENTER>

Is used to select and confirm/store the current selection.

### <UP>

Scrolls through menu items and numbers in ascending order.

### <DOWN>

Scrolls through menu items and numbers in descending order.

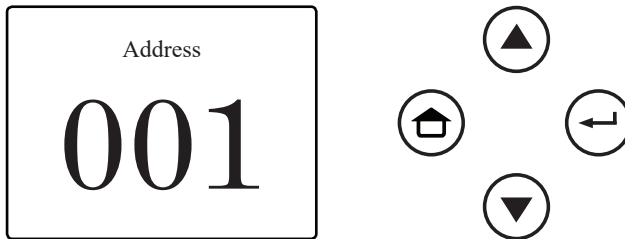

The control panel display shows the menu items you select from the menu map on page #12. When a menu function is selected, the display will show immediately the first available option for the selected menu function. To select a menu item, press <ENTER>.

Use the <UP> and <DOWN> buttons to navigate the menu options. Press the <ENTER> button to select the menu function currently displayed, or to enable a menu option. To return to the previous option or menu without changing the value, press the <MENU> button.

## Control Panel Menu Structure

<b>Addr</b>	Address	Set the starting address (001-512)	
<b>CH Mode</b>	Channels	8 Channels	
		15 Channels	
		23 Channels	
<b>Dim</b>	Dimmer Profiles	Fast fade	
		Smooth dimming	
<b>Input</b>	Main Menu	Display Invert	Yes
			No
		Run Mode	DMX512
			Auto
		Sound	
	Slave Mode	Slave 1 (normal)	
		Slave 2 (contrast movement)	
	Sound Sensitivity	Sound Sensitivity (001-100)	
	DMX Fail	Blackout	(default action upon loss of signal)
		Hold (last signal)	
Backlight	On		
	Off		
Version	Software version information		
<b>Inv Pan</b>	Invert Pan	Yes	
		No	
<b>Inv Til</b>	Invert Tilt	Yes	
		No	

## DMX Mode

Allows the unit to be controlled by any universal DMX controller.

### Select the Starting DMX Address

- 1.) Navigate the main menu to reach **Addr**, press **<ENTER>**.
- 2.) Use the **<UP/DOWN>** buttons to choose a starting DMX address ranging from 001-512, press **<ENTER>** to confirm, or **<MENU>** to exit.

### Select the DMX Channel Mode

- 1.) Navigate the main menu to reach **CH Mode**, press **<ENTER>**.
- 2.) Use the **<UP/DOWN>** buttons to highlight your choice, and press **<ENTER>**.

### Select the DMX Run Mode

- 1.) Navigate to **Input > Run Mode**, then **DMX512**, and press **<ENTER>**.

### Master/Slave Mode Settings

- 1.) Daisy chain fixtures together via DMX input/output connections.
- 2.) On slave units, navigate to **Input > Slave Mode**, then **Slave 1** or **Slave 2**.
- 3.) **Slave 1** fixtures will follow the master exactly, and **Slave 2** fixtures will have contrasting movements to the master fixture.

### Auto and Sound Active Modes

Allows a single or Master/Slaved units to run factory installed programs.

- 1.) Navigate to **Input > Run Mode**, then **DMX512**, and press **<ENTER>**.
- 2.) Highlight **Auto** or **Sound** and press, and press **<ENTER>**.
- 3.) To adjust the mic sensitivity level for use during sound active mode, navigate to **Input > Sound Sensitivity**, and press **<ENTER>**.
- 4.) Use the **<UP/DOWN>** buttons to choose a sensitivity level ranging from **001-100**, then press **<ENTER>** to confirm.

## DMX Values In-Depth (8/15/23-Channel Modes)

8CH	15CH	23CH	Value	What It Does
1	1	1	000 <-> 255	Pan
--	2	2	000 <-> 255	Fine Pan (16-bit)
2	3	3	000 <-> 255	Tilt
--	4	4	000 <-> 255	Fine Tilt (16-bit)
--	5	5	000 <-> 255	Pan/Tilt Speed (fast <-> slow)
3	6	6	000 <-> 255	Zoom (wide <-> narrow)
4	7	7	000 <-> 255	Dimmer (0% <-> 100%)
--	8	8	000 <-> 255	Strobe (slow <-> fast)
--	9	9	000 <-> 009	<b>Color Macros</b> No function
				<i>Static Colors:</i>
			010 <-> 019	Red
			020 <-> 029	Green
			030 <-> 039	Blue
			040 <-> 049	White
			050 <-> 059	Yellow
			060 <-> 069	Purple
			070 <-> 079	Teal
			080 <-> 089	Lt Lavender
			090 <-> 099	Blue - Green - Red
			100 <-> 109	Red - White
			110 <-> 119	White - Yellow
			120 <-> 129	Blue - White - Blue
			130 <-> 139	Purple - White
			140 <-> 149	White - Red
			150 <-> 159	Blue - Purple - Yellow
			160 <-> 169	Purple - White - Purple
				<i>Color Chases:</i>
			170 <-> 179	Solid Colors
			180 <-> 189	Ring Chase (in <-> out)
			190 <-> 199	Color Fill (in <-> out)
			200 <-> 205	RGB (in <-> out)
			206 <-> 214	Random colors
			215 <-> 223	Fading Rings
			224 <-> 232	Pulse RGB (up <-> down)
			233 <-> 241	Pulse Solid Colors (up <-> down)
			242 <-> 250	In+Out / Mid Fade RGB
			251 <-> 255	Bounce Fade RGB (in <-> out)
--	10	10	000 <-> 255	Color Macro Speed (fast <-> slow)
5	11	--	000 <-> 255	Red Intensity
6	12	--	000 <-> 255	Green Intensity
7	13	--	000 <-> 255	Blue Intensity
8	14	--	000 <-> 255	White Intensity
--	--	11	000 <-> 255	Inside Red
--	--	12	000 <-> 255	Inside Green
--	--	13	000 <-> 255	Inside Blue
--	--	14	000 <-> 255	Inside White
--	--	15	000 <-> 255	Middle Red
--	--	16	000 <-> 255	Middle Green
--	--	17	000 <-> 255	Middle Blue
--	--	18	000 <-> 255	Middle White
--	--	19	000 <-> 255	Outside Red
--	--	20	000 <-> 255	Outside Green
--	--	21	000 <-> 255	Outside Blue
--	--	22	000 <-> 255	Outside White
--	15	23	000 <-> 255	Reset

# 5. APPENDIX

## Keeping Your Flurry™ Z As Good As New

Cleaning the optics routinely with a suitable glass cleaner will greatly improve the quality of light output. Keeping the fans free of dust and debris will keep the fixture running cool and prevent damage from overheating.

In transit, keep the fixtures in cases. You wouldn't throw a prized guitar, drumset, or other piece of expensive gear into a gear trailer without a case, and similarly, you shouldn't even think about doing it with your shiny new light fixtures.

## Returns (Gasp!)

We've taken a lot of precautions to make sure you never even have to worry about sending a defective unit back, or sending a unit in for service. But, like any complex piece of equipment designed and built by humans, once in a while, something doesn't go as planned. If you find yourself with a fixture that isn't behaving like a good little fixture should, you'll need to obtain a Return Authorization (RA).

Don't worry, this is easy. Just visit [www.blizzardpro.com/support](http://www.blizzardpro.com/support) and open a support ticket, and we'll issue you an RA. Then, you'll need to send the unit to us using a trackable, pre-paid freight method. We suggest using USPS Priority or UPS. Make sure you carefully pack the fixture for transit, and whenever possible, use the original box & packing for shipping.

When returning your fixture for service, be sure to include the following:

- 1.) Your contact information (Name, Address, Phone Number, Email address).
- 2.) The RA# issued to you
- 3.) A brief description of the problem/symptoms.

We will, at our discretion, repair or replace the fixture. Please remember that any shipping damage which occurs in transit to us is the customer's responsibility, so pack it well!

## Shipping Issues

Damage incurred in shipping is the responsibility of the shipper, and must be reported to the carrier immediately upon receipt of the items. Claims must be made within seven (7) days of receipt.

## Dimensional Drawings

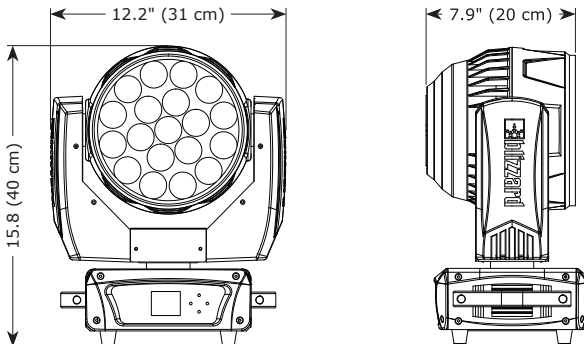

## Tech Specs!

<b>Weight &amp; Dimensions</b>	
Width	12.2 inches (310 mm)
Depth	7.9 inches (200 mm)
Height	15.8 inches (400 mm)
Weight	17.5 lbs. (7.9 kg)
<b>Power</b>	
Operating Voltage	90-240VAC, 50-60Hz
Power Consumption	230W, 2.94A, PF: .68
Fuse	5A/250V
<b>Light Source</b>	
LED	19* 15W 4-in-1 RGBW LEDs
Beam Angle	5°-50° motorized zoom
<b>Movement Range</b>	
Pan	540 degree pan
Tilt	280 degree tilt
<b>Thermal</b>	
Max. Operating Temp.	104 degrees F (40 degrees C) ambient
<b>Control</b>	
Protocol	USITT DMX-512
DMX Channels	8/15/23-channel modes
Input/Output	3-pin XLR Male/Female
Operating Modes	DMX512, Master/Slave, Auto, & Sound Active
<b>Warranty</b>	
2-year limited warranty, does not cover malfunction caused by damage to LEDs	

## Photometric Data

### 5° Beam Diameter:

- 1.) 2.5m: 8.9 inches (22.5 cm)
- 2.) 5m: 1.5 feet (45 cm)
- 3.) 7.5m: 2.3 feet (67.5 cm)
- 4.) 10m: 3.0 feet (90 cm)

### 50° Beam Diameter:

- 1.) 2.5m: 7.4 feet (225 cm)
- 2.) 5m: 14.8 feet (450 cm)
- 3.) 7.5m: 22.2 feet (675 cm)
- 4.) 10m: 29.6 feet (900 cm)

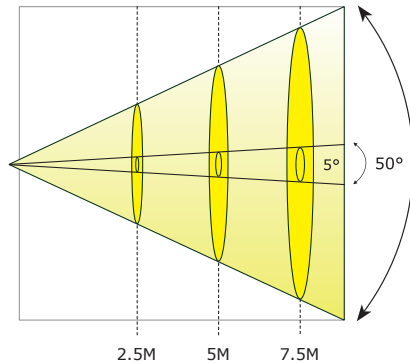

### Luminous Intensity:

Beam	2.5m lux	2.5m fc	5m lux	5m fc	7.5m lux	7.5m fc	10m lux	10m fc
50°	2,166	201.2	512	47.6	276	25.6	182	16.9
5°	25,288	2,349.4	5,986	556.1	2,758	256.3	1,599	148.6

### DISCLAIMER:

The power connector fitted to the fixture and fixture cord are designed for compatibility with products manufactured by Neutrik AG, Neutrik USA and their related entities, however they are not manufactured by, affiliated with or endorsed by Neutrik AG, Neutrik USA, or any related entity. Neutrik® and power-CON® are registered trademarks of Neutrik AG.



**Enjoy your product!  
Our sincerest thanks for your purchase!  
--The team @ Blizzard Lighting**