

SB9600

Tripod Studio Boom

MICROPHONE STANDS

FEATURES AND BENEFITS

Our most affordable and most stable studio boom combines a tripod base, two straight booms and a 7" mini boom extension into one mean microphone support machine. The boom shafts can be attached for professional studios with ample space. Or remove the front half of the boom and use the back boom for project studios where space is a concern. With this fold-and-go convenience and steel tubing, this is a great item for any budget!

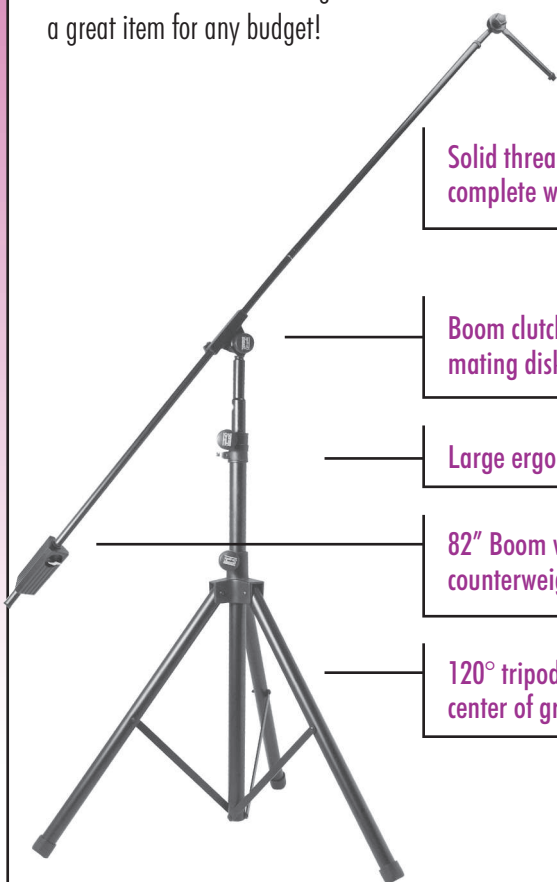

Solid threaded boom ends complete with washers.

Boom clutch assembly features 2" mating disks w/ 40 locking teeth.

Large ergonomic locking knobs.

82" Boom with 7 lb. sliding counterweight that locks in place.

120° tripod leg design and low center of gravity for added stability.

Ask about our microphone stand accessories ...

MY-410

Studio Mic Shock Mount
Fits most large diaphragm condenser mics. Die-cast steel adapter with 5/8"-27 threads.

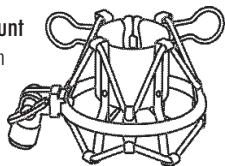

MY-110

Unbreakable Wireless Rubber Mic Clip
Straight style, 5/8"-27 female threads. Black finish.



COLOR Packaging



Our award-winning packaging is eye-catching and supplies all of the product features!

PRODUCT SPECIFICATIONS

- > **Applications:** Professional, project and home recording studios, live performances, equipment rentals and field audio/video and TV production.
- > **Height Adj.:** 44"-80"
- > **Base Spread:** 32"-48"
- > **Boom Length:** 82"
- > **Color:** Black Powder Coat Finish

Model#: **SB9600**
List Price: **\$179.00**

Call The Music People today to place your order

1-800-289-8889

Visit us on the web @ www.musicpeopleinc.com or www.onstagestands.com

On-Stage Stands® is a registered trademark of The Music People Inc. Prices and Specifications subject to change.

On-Stage Stands®