

# Professional UHF Wireless Systems

## ATW-BH1 Antenna Bulkhead Connector Kit

### Installation and Operation



The Audio-Technica ATW-BH1 is an antenna bulkhead connector kit.

The ATW-BH1 allows you to mount antennas away from the receiver. When wireless receivers are installed in metal equipment racks or other enclosures, it may be necessary to locate the antennas on the outside of the enclosure or on a separate rack panel in the enclosure in order to improve RF performance.

#### Kit Contents:

Each ATW-BH1 Antenna Bulkhead Connector Kit contains two BNC bulkhead connectors with mounting hardware and two 3' RG-58 BNC – BNC cable assemblies. (Note: this kit does not contain antennas, drill bits or "D" punches.)

#### Installing and Using the ATW-BH1:

**First**, determine the locations for each of the BNC bulkhead connectors. Possible locations include the top of an equipment rack, the sides of the rack, or a blank panel mounted to the front or rear of the rack. If the kit is being used to remotely mount the receiver's standard antennas, please observe the following recommendations:

1. The BNC connectors must be mounted to a metal surface at least 8" W x 8" L to maintain the proper ground plane requirements for the antenna. The metal surface must be no thicker than 0.217" (5.5 mm).
2. Each pair of antennas should be spaced at least 8" apart.

3. There must be sufficient clearance behind the BNC bulkhead connector to accommodate the BNC cable and its connector.

**Second**, punch or drill a mounting hole in the desired location for each BNC bulkhead connector.

Maximum panel thickness: 0.217" (5.5 mm).

Recommended dimensions of the mounting hole (see diagram): 0.476" (12.10 mm) high; 0.512" (13.00 mm) wide.

**Third**, mount each BNC bulkhead connector using the included hardware. Place the toothed lock-washer between the panel and rear nut (see diagram below). Tighten the rear nut securely to ensure a good ground connection. **Note:** If the panel surface is painted, make certain that a solid metal-to-metal contact is made between the bulkhead connector and panel.

**Fourth**, attach one end of each included BNC cable to each BNC bulkhead connector; attach the other end of each included BNC cable to the wireless receiver's or antenna distribution amplifier's antenna input connection.

**Finally**, mount the receiver's antennas to each of the BNC bulkhead connectors.

BNC bulkhead connector  
with mounting hardware

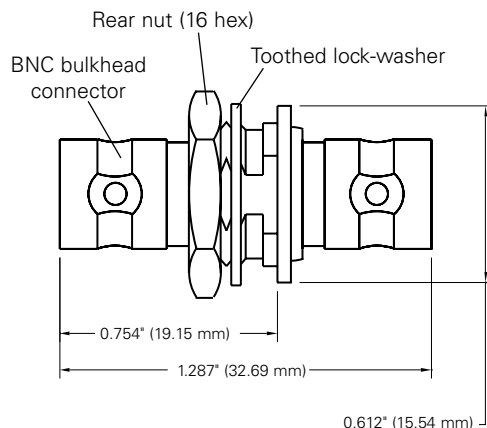

Note: Place the toothed lock-washer between the panel and rear nut.

Recommended mounting hole

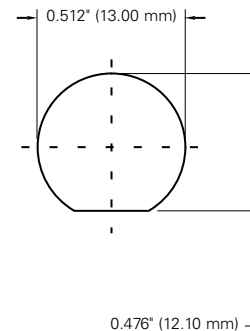

Note: Maximum panel thickness: 0.217" (5.5 mm).

To reduce the environmental impact of a multi-language printed document, product information is available online at [www.audio-technica.com](http://www.audio-technica.com) in a selection of languages.

Afin de réduire l'impact sur l'environnement de l'impression de plusieurs, les informations concernant les produits sont disponibles sur le site [www.audio-technica.com](http://www.audio-technica.com) dans une large sélection de langue.

Para reducir el impacto al medioambiente, y reducir la producción de documentos en varios leguajes, información de nuestros productos están disponibles en nuestra página del Internet: [www.audio-technica.com](http://www.audio-technica.com).

Para reduzir o impacto ecológico de um documento impresso de várias linguas, a Audio-Technica providência as informações dos seus produtos em diversas linguas na [www.audio-technica.com](http://www.audio-technica.com).

Per evitare l'impatto ambientale che la stampa di questo documento determinerebbe, le informazioni sui prodotti sono disponibili online in diverse lingue sul sito [www.audio-technica.com](http://www.audio-technica.com).

Der Umwelt zuliebe finden Sie die Produktinformationen in deutscher Sprache und weiteren Sprachen auf unserer Homepage: [www.audio-technica.com](http://www.audio-technica.com).

Om de gevolgen van een gedrukte meertalige handleiding op het milieu te verkleinen, is productinformatie in verschillende talen "on-line" beschikbaar op: [www.audio-technica.com](http://www.audio-technica.com).

本公司基於環保理由將減少多語言文件印刷，陸續產品訊息可在 [www.audio-technica.com](http://www.audio-technica.com) 的官方網頁上選擇語言與瀏覽。

本公司基于环保理由将减少多语言文件印刷，陆续产品信息可在 [www.audio-technica.com](http://www.audio-technica.com) 的官方网页上选择语言与浏览。

자원절약, 환경보호를 위해 국문 사용 설명서는 인쇄하지 않았습니다.  
제품정보는 [www.audio-technica.com](http://www.audio-technica.com) 에서 원하는 언어 선택 후에 다운로드 받으실 수 있습니다.



**Audio-Technica U.S., Inc.**, 1221 Commerce Drive, Stow, Ohio 44224 330/686-2600 [www.audio-technica.com](http://www.audio-technica.com)  
**Audio-Technica Limited**, Old Lane, Leeds LS11 8AG England 0113 277 1441 [www.audio-technica.co.uk](http://www.audio-technica.co.uk)