



Scan for full manual

KT-107-INWB Quick Start Guide

This guide helps you install and use your **KT-107-INWB** for the first time.

Go to www.kramerav.com/downloads/KT-107-INWB to download the latest user manual and check if firmware upgrades are available.

Step 1: Check what's in the box

- ✓ KT-107-INWB In-Wall Box for KT-107 Touch Panel
- ✓ 1 Quick start guide
- ✓ 4 M3x8 screws with washers

Step 2: Get to know your KT-107-INWB

KT-107-INWB is used for installing a touch panel in a concrete wall.

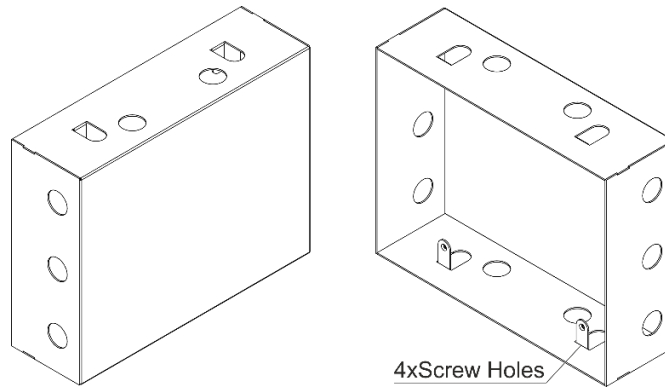

Step 3: Install the KT-107-INWB

For concrete or block wall surfaces:

- i** Use the Kramer **KT-107-INWB** In-Wall Box for KT-107 Touch Panel for concrete installations.
 1. Make sure that the prepared opening in the concrete fits the dimensions of the in-wall junction box.
 2. Insert the **KT-107-INWB** into the opening.
 3. Carry out Touch Panel installation instructions as described in **KT-107-INWL** Quick Start: www.kramerav.com/downloads/KT-107-INWL
- i** Make sure to place the **KT-107-INWB** flush with the plaster surface.

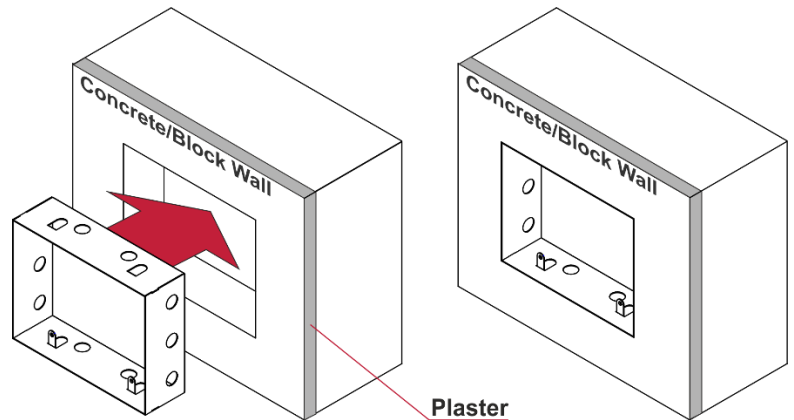

Technical Specifications

Environmental Conditions	Operating Temperature	0° to +40°C (32° to 104°F)
	Storage Temperature	-40° to +70°C (-40° to 158°F)
	Humidity	10% to 90%, RHL non-condensing
Regulatory Compliance	Safety	CE
	Environmental	RoHs, WEEE
	Type	Steel
General	Net Dimensions (W, D, H)	20cm x 6cm x 15.5cm (7.9" x 2.4" x 6.1")
	Shipping Dimensions (W, D, H)	34.4cm x 6.8cm x 21 cm (13.5" x 2.7" x 8.3")
	Net Weight	0.6kg (1.3lbs) approx.
	Shipping Weight	0.8kg (1.8lbs) approx.
Accessories	Included	4 M3x8 screws with spring washers 4 flat washers