

THE 450 DUAL ZONE PRIORITY MIXER satisfies the requirements for paging mic and mono/stereo line mixing in clubs, restaurants, hotels, conference facilities, houses of worship or anywhere multiple audio inputs must be combined and distributed. The compact one rack space mixer accepts two mono mic/line inputs (with +48V phantom power and low frequency filters) and four stereo line inputs.

Each input may be assigned to a stereo output zone, a mono output zone or both. A unique hierarchical priority structure permits both mic/line inputs and the first stereo line input to have priority over the other inputs assigned to the same zone. For example, in a typical configuration, a paging microphone assigned to the stereo zone will have priority over a background music (connected to line input 5-6) in that zone. A jukebox (connected to line input 3-4) in the same zone will have priority over the background music, but the paging signal will retain ultimate priority and

force muting of both the jukebox and the background music whenever the page mic is used.

As a result of its inherent flexibility the 450 is a perfect low cost solution for many small system requirements. By accepting audio inputs from virtually any type of audio source and selectively routing to either the mono or stereo output zone the 450 can save you time and money in the design and installation of your next project. •

APPLICATIONS

- Restaurants, Pubs, Bars
-
- Conference Rooms
-
- Multi Zone Paging
-
- Church and School Public Address
-
- Hotel Convention Facilities
-

FEATURES

- Separate stereo and mono output zones
-
- Four stereo inputs (may be used as mono)
-
- Two mic/line inputs with +48v phantom power
-
- Three inputs have priority override capability
-
- Remote volume control capability
-
- Uncompromising sound quality
-

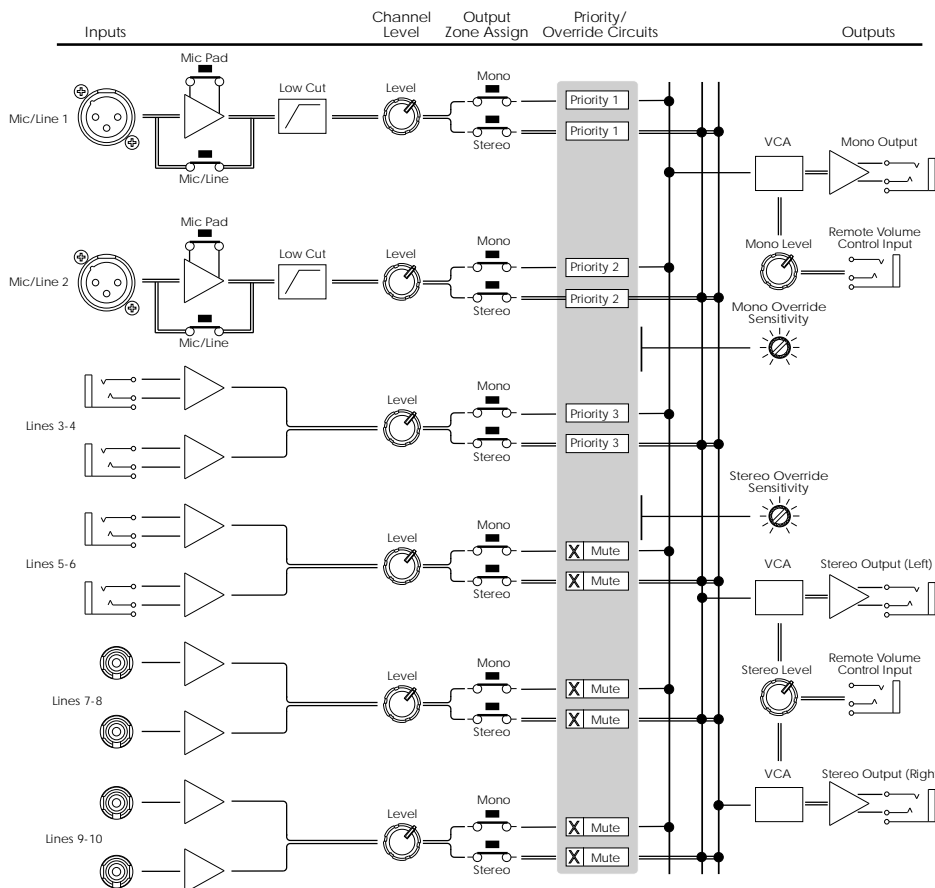

450

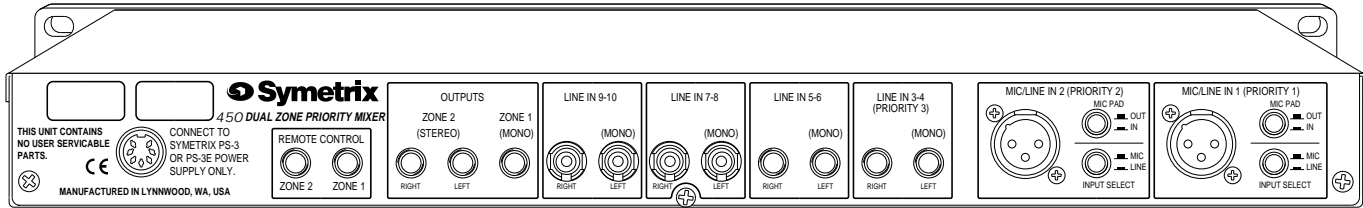

SPECIFICATIONS

Specifications subject to change without notice.

Audio		Physical	
Microphone Inputs	Two, Low Impedance, Balanced	Size (hwd)	1.72 x 19 x 6.5 inches, 4.37 x 48.26 x 16.51 centimeters
Mic Common Mode Rejection @ 1 kHz, 1V RMS	>85 dB	Weight	8 lbs (3.64kg) net
Phantom Power	+48V (10ma per input max)	Electrical	
Line Inputs	Four, Stereo	Power requirements	117V nominal, 95 to 130V AC, 50 to 60 Hz, 15 watts 230V nominal, 165 to 255V AC, 50 Hz, 15 watts
Line Input Impedance	>10k Ohms, Balanced		
Line Input Common Mode Rejection @ 1 kHz, 1V RMS	>40 dB		
Maximum Line Input Level	+24 dBu Balanced, +18 dBu Unbalanced		
Frequency Response, Any Input to Any Output	±1 dB, 20 Hz to 20 kHz		
Connections			
Microphone Inputs	XLR Female (pin 2 high)		
Line Inputs	¼" TRS (tip is high), RCA-phono (Unbalanced)		
Line Outputs	¼" TRS (tip is high)		
Remote Volume Control Inputs	¼" TRS		

450 ARCHITECTS AND ENGINEERS SPECIFICATIONS

The audio microphone and line mixer shall be a high performance unit occupying a single rack space (1U).

The unit shall have two low impedance, balanced microphone/line inputs with connection via female XLR. Each microphone/line input shall have a rear panel push-button which shall bypass the mic preamp circuitry. Each input shall also have a switch to reduce the gain of the mic input by 20dB. Associated with each microphone input shall also be a front panel level control potentiometer whose purpose is to establish the level of the microphone channel as it is mixed to either a mono output zone, a stereo output

zone, or both simultaneously. Each microphone input shall also have a first order low cut filter with a 100 Hz roll-off frequency.

The mic/line mixer shall have four stereo, line level inputs. Each input shall be assignable to either a monaural output zone, a stereo output zone, or both. Associated with each line input shall be a level control potentiometer whose purpose is to establish the level of the line level input signal as it is mixed to either a mono output zone, a stereo output zone, or both simultaneously.

The 450 shall incorporate a four level priority muting system as follows. High

priority inputs shall mute or duck all lower priority inputs that are assigned to it's output zone when audio is present at it's (the higher priority) input. There shall be a threshold control in each zone master section which determines the minimum level of audio that will trigger the muting/ducking function. Priority shall be assigned as follows: Input 1 - priority 3 (top priority), input 2 - priority 2, stereo input 3/4 - priority 1, stereo inputs 5-10 - no priority.

Independent master output level controls shall be provided for both the monaural output zone and the stereo output zone. LED peak meters shall indicate the actual

output level regardless the nature of the load.

Independent means shall be provided to remotely control the output level of the mono output zone and the stereo output zone. Rear panel jacks shall be provided to accept connections from standard 50K linear potentiometers for this purpose. When wired for remote control, the front panel output zone controls shall be disabled.

The mic/line mixer shall be a Symetrix, Inc. model 450 Dual Zone Priority Mixer.

450