

# REALiS

Canon's LCOS Projectors:  
Exceptional Color. Intricate Detail.



**Canon**  
image*ANYWARE*



# The Difference is in The Details

Canon's REALiS brand projectors feature LCOS (liquid crystal on silicon) technology, recently described by a leading trade magazine as "sort of a 'best of breed' combination of LCD and DLP technologies." LCOS technology produces lattice-free seamless images, and unlike LCD has no "screen door effect" to mute color and detail. LCOS technology has been highly coveted for providing extremely crisp images, intricate details,

easy-to-read type (as small as 7 pt.) and "HD images that jump out at the viewer in breathtaking quality," making it the ideal projector for demanding uses and applications. These include medical image presentations, display of CAD engineering drawings and blueprints, faithful color reproduction of professional photography, as well as countless uses for business, higher education and government.

## REALiS LCOS Projectors vs. Transmissive LCD Projectors

The surface area of each pixel in Transmissive LCD projectors is small, creating an overall grid-like lattice effect ("screen door effect"), which results in muted colors and text that appears faint and uneven. REALiS LCOS projectors have minimal gaps between the pixels, creating color-rich, detailed images, and text that appears dark and crisp. The advantages are easy to see:

### LCOS vs. DLP

LCOS Technology displays even subtle color gradation and tones of black and grey, which enhance visual accuracy, while DLP has a limited grey scale.

### Display of Fine Lines

Display of fine lines: CAD images, blueprints, and fine lines are reproduced smoothly and accurately with REALiS high-resolution projectors.



### Display of Color and Detail

REALiS SXGA+ models can be presented with exceptional color and intricate detail.

### Display of Small Text

By using more pixels for each letter, REALiS projectors can display easy-to-read type, as small as 7 pt. often illegible on LCD-based XGA projectors.

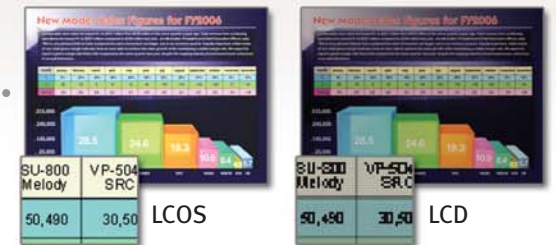

### Display of Fine Grained Objects

REALiS lattice-free images ensures smooth, crisp displays of fine grained objects, including metallic surfaces, typically dulled by LCD projectors.

# Canon's LCOS Projectors: What's Behind "Color So Real?"

## The Secret is AISYS-Enhanced LCOS Technology

Canon's proprietary AISYS optical system enhances LCOS technology to achieve crisp, color-rich, intricately-detailed images by efficiently utilizing and equalizing light from the projector lamp. This unique technology effectively boosts the performance functions of brightness and contrast to optimize image quality, in a more compact housing that maximizes affordability. New Optical elements were incorpo-

rated into the illumination optical system to enhance uniformity of light. The Polarizing Beam Splitters (PBS) in the color separation and recombination system were redesigned for more precise light control (SX6, SX60 and X600 models) resulting in a new standard in bright, beautiful, high-contrast projected images.

### Advantages of the AISYS Optical System

- Seamless image
- High Contrast
- Compact Size
- High Definition
- Accurate Color Reproduction
- Brightness

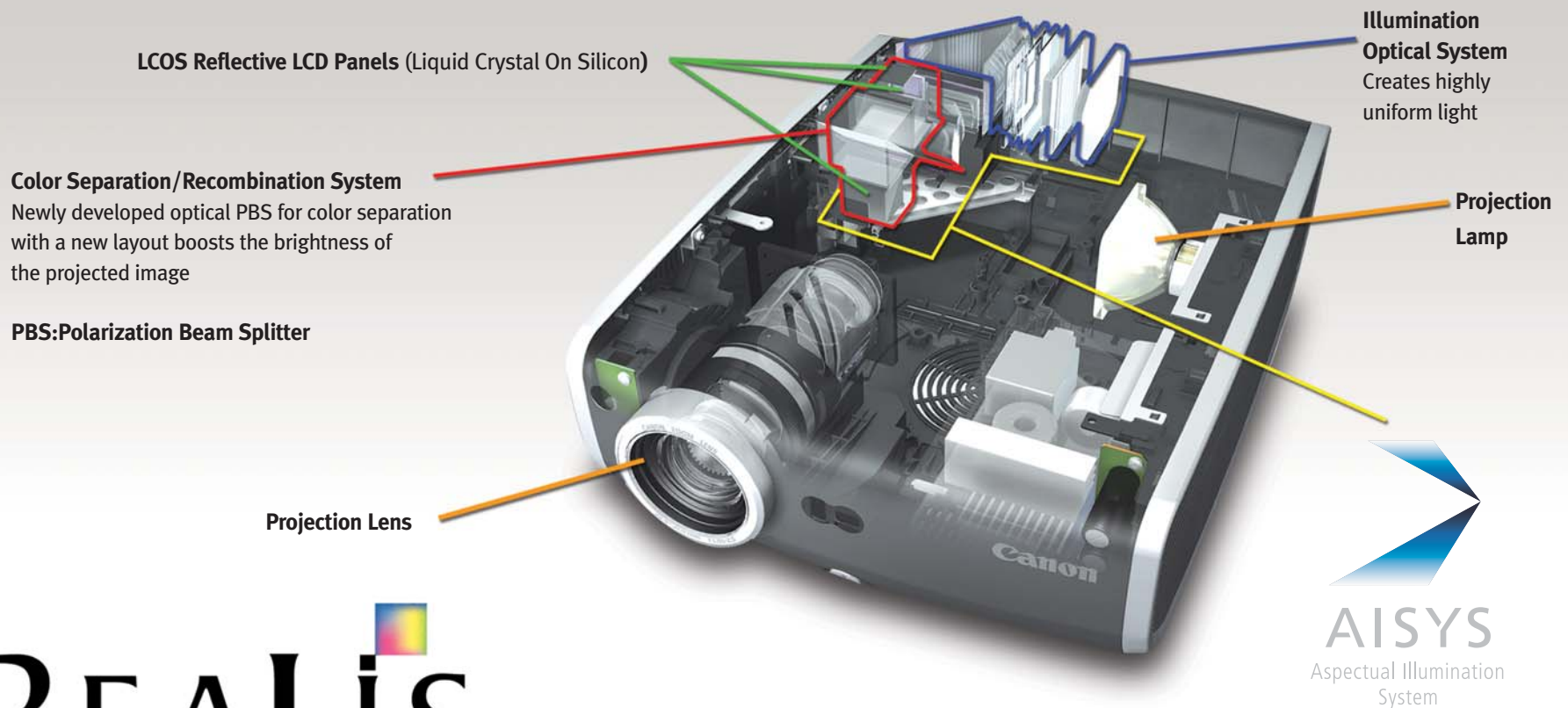

# REALiS



## Professional Photography



## Medical Imaging

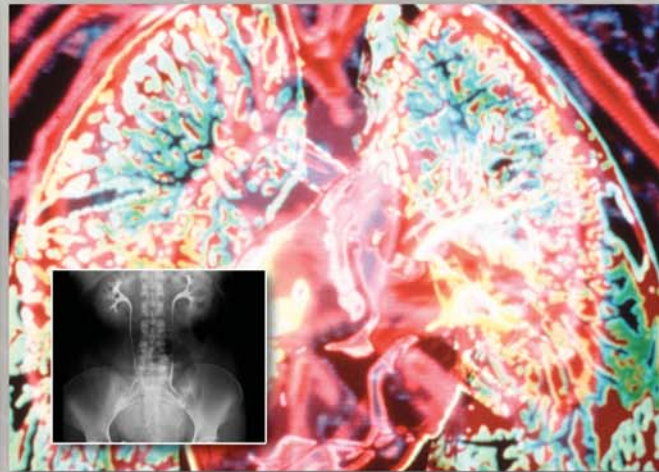

## Engineering Design



SX6



SX60

### REALiS SX6

**HD  
ready**

- SXGA+ (1400x1050)
- LCOS and AISYS Improved
- 1.7x Powered Zoom Lens
- 3500 ANSI Lumens
- 1000:1 Contrast Ratio
- Adobe RGB Color Match System
- Auto Set-up
- HDCP Compliant

### REALiS SX60

**HD  
ready**

- SXGA+ (1400x1050)
- LCOS and AISYS Improved
- 1.7x Powered Zoom Lens
- 2500 ANSI Lumens
- 1000:1/2000:1 Contrast Ratio
- Home Cinema Mode
- Auto Set-up
- HDCP Compliant





# The REALiS Advantage

Canon's three new LCOS Multimedia Projectors, the REALiS SX6, REALiS SX60, and REALiS X600 join the award-winning REALiS SX50 to create an impressive line-up of high and super-high (SXGA+) resolution projectors. Whether it's medical and engineering professionals displaying intricately-detailed, color-rich images; professional photographers or graphic artists needing to precisely match Adobe RGB color; business people or educators presenting charts and images in stunning detail; government or security users requiring exacting imagery; or even discerning home theatre enthusiasts, Canon's new REALiS Multimedia Projector line provides the features and performance to meet their needs.

## Auto Set-up



Press Auto Set, and within seconds your input source is connected, distortion corrected, focus sharpened and color balanced.



## Auto Keystone

Automatically calculates the angle of the projector and corrects for image distortion. Vertical ( $\pm 20^\circ$ ).



## Auto Focus

An infrared sensor on the front of the unit measures the distance to the screen and adjusts the focus in as quickly as one second.

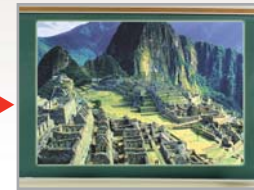

## Auto Screen Color

Automatically adjusts the color balance according to the projection surface's color.

Input Signal	Digital PC	Terminal	DVI-I
	Digital Video		DVI-I
	Analog PC		DVI-I, Mini D-sub 15
	Component		Mini D-sub 15
	SCART		Mini D-sub 15
	Video		RCA signal
S-Video	Mini DIN4		

## Auto Input

Automatically detects the image signal from the input terminal, identifies it as the input signal and selects it for display.

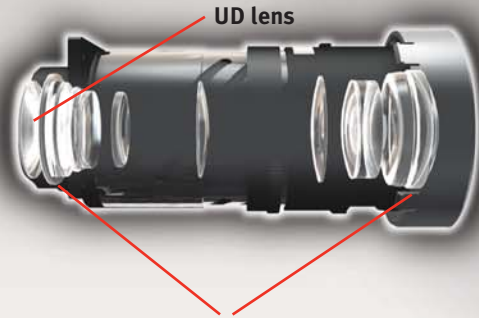

## Genuine Canon Optics 1.7x Power Zoom Lens

Canon's SX6, SX60 and X600 are equipped with a 1.7X Powered Zoom Lens. The lens configuration is a six-group assembly with 12 elements and four moving groups, featuring one UD lens and two high-precision double-sided aspherical lenses.

Two high-precision double-sided aspherical lenses

## Throw Distance

The 1.7x Ultra-Wide Powered Zoom Lens has the widest zoom range of any of Canon's projector lenses, giving you a diagonal screen size range of 40" (at a very short distance of 3.9') to 100" at 9.8' and up to 300" maximum. (See chart page 11.)

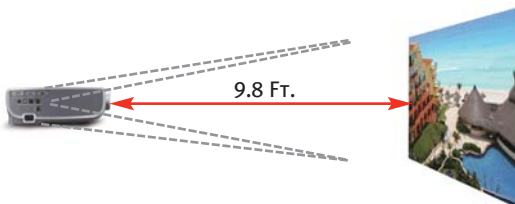

Placement for projection on a 100-inch screen.

## Off and Go

The SX6, SX60, and X600 models are equipped with an internal charging system to run the fan. This makes it possible to unplug the projector right after using it, while the internal charging system keeps the fan running.



Internal charging system for cooling fan.



When presentation is finished, the unit can be unplugged immediately.

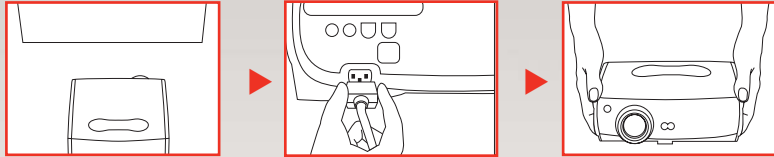

## Direct Power ON

The SX6, SX60 and X600 can be switched on and off from a central control terminal without actually pressing the buttons on the main unit, permitting remote operation when the projector is mounted overhead. It is also possible to control the power supply by simply connecting or disconnecting the power cable.

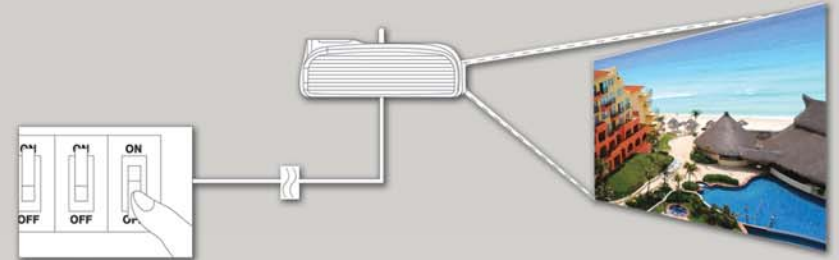

When Direct Power setting is 'On', the projector starts up automatically when power is supplied and is ready to display images in approx. 20 seconds.

# Feature-Rich Technology Engineered For Excellence.

Compatible with a variety of image input signals, including HDTV.

The SX6, SX60, and X600 models feature DVI-I and analog component HD input interfaces. In addition to SD signals from DVD players, these projectors can display high-definition digital video signals as large as 1080i.

- HDCP Compliant DVI-I terminal, Motion Adaptive IP conversion, and Film Mode (2-3 Pull down)



## Image Modes

Select the image mode to suit the characteristics of the content: "Presentation" mode for briefings and conferences, "Adobe RGB" or "sRGB" when color reproduction is critical, etc.

- Standard:** Prioritizes reproduction of white, closely matching the image characteristics of the original
- Presentation:** Produces a bright, high-contrast display for ease of viewing text and numerical data
- Movie/Cinema:** Suitable for displaying theatrical content; image quality emphasizes gradations in dark areas
- Movie & Photo:** For display of video and digital camera images; clearly defines gradations and improves color reproduction
- Adobe RGB/sRGB:** Reproduces colors in the appropriate color space for accurate projection of content produced in specific standardized formats
- Home Cinema:** Controls brightness while enhancing contrast to a ratio of 2000:1; for display of theatrical content in pitch-dark rooms

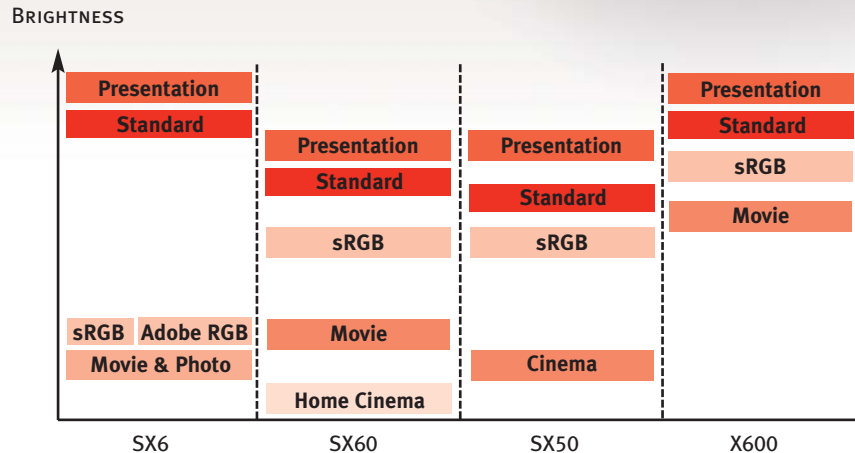

## More Faithful Color: Special Color Filters for Adobe RGB and Home Cinema achieve Expanded Color Space

Sophisticated Canon color management technology, initially developed for digital cameras and printers, has been adapted for the new line of multimedia projectors. Proprietary color filters incorporated in the AISYS optical system expand the color space that can be displayed. The SX6 is fitted with a special RGB color filter that enables 100% support of sRGB and virtually accurate reproduction of Adobe RGB. The SX60 Cinema filter makes it possible to display the original colors of the film before conversion to a video signal.

## Adobe RGB Color Match System

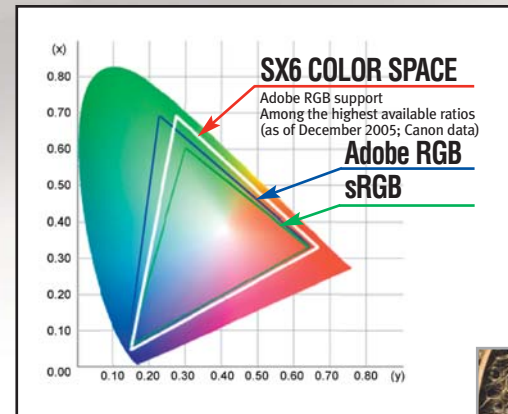

A special RGB color filter on the SX6 enables virtually accurate Adobe RGB color as well as sRGB, which is ideal for professional photography, design, publishing and printing. (SX6 only)

REALiS projectors produce scanless, grid-free images for realistic reproduction of colors and textures in photos.





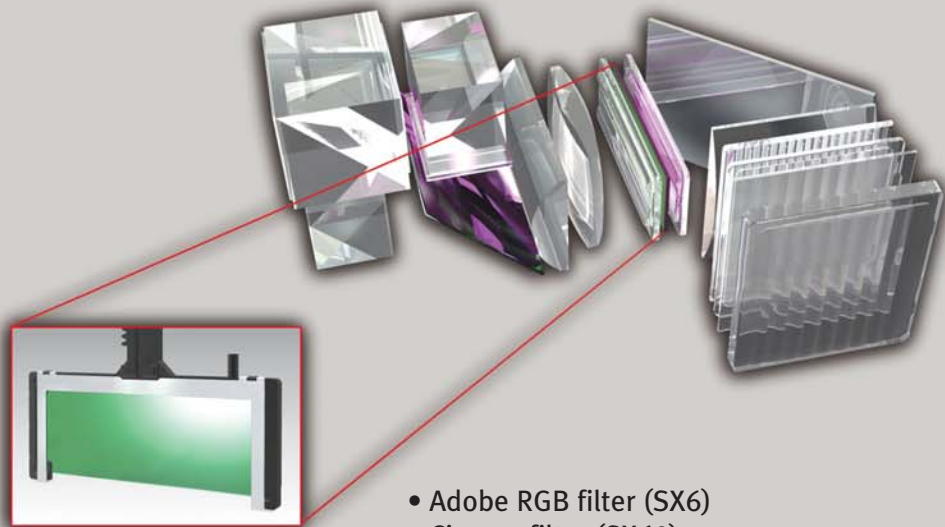

- Adobe RGB filter (SX6)
- Cinema filter (SX60)

## Home Cinema Mode

The SX60 multimedia projector is equipped with a home cinema filter making it ideal for this application.



## Crisp Blacks Create Rich Shadow Detail

Precise control prevents excess light leakage, producing rich, detailed gradation even in shadowed portions of projected images. And the crisp blacks produced by the LCOS reflective panels create images with realistic depth and dimension.



Conventional Home Use Projector

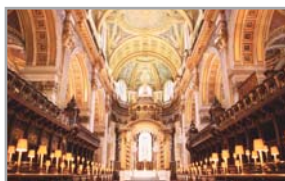

SX60

## 6-Axis Color Adjustments

A 6-Axis Color Adjustment function has been incorporated to meet the demands of professionals with demanding color requirements. Both hue and saturation can be adjusted on independent RGB and CMYK color axes.

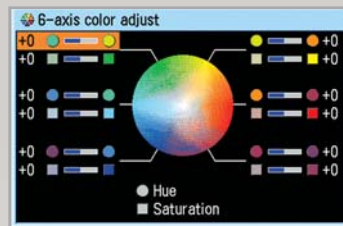

More orange in the sunset



A bluer sky



## Dynamic Gamma

When dynamic gamma is 'on' gamma is automatically adjusted to optimum values. When projecting moving images with rapid shifts in brightness, each frame is displayed with optimum contrast balance to prevent washed-out whites and blocked-up blacks.

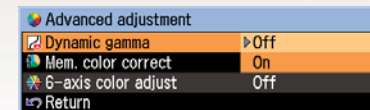

In bright scenes, gamma is adjusted according to the brightness, automatically compensating for washed-out areas and reproducing gradation in the bright sections.

In scenes containing dark areas, gamma is adjusted for the entire image, including dark sections, minimizing blocked-up shadows.



## Quiet Operation

In a projector, heat is generated by its projection lamp and power-supply circuits. The cooling system required to dissipate this heat is one of the main reasons why projectors tend to be noisy. In the new SX6, SX60 and X600, ventilation vents, cooling fan, and layout of the optical array have been engineered with noise prevention in mind, resulting in exceptionally quiet operation.

- ▶ Vents designed for efficient cooling
- ▶ In-line layout for unobstructed ventilation
- ▶ Large fan operates at lower speed

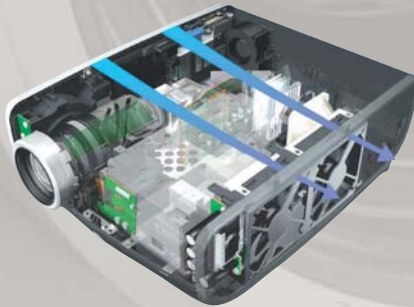

## LED Illumination

LEDs on the SX6, SX60 and X600 indicate the projector's connections and operational status at a glance. When several image input devices are connected, a LED indicates which image signal is selected as the input. The LED illumination on the operation panel flashes to indicate start-up, end of presentation, and other user commands.

Input terminals



LED indicates connector responding to image signal.

Operations panel



LEDs flash to indicate/confirm specific operations.

## Convenient Remote Control functions for sophisticated presentations

### Digital Zoom

Enlarges a selected single area of the screen, such as specific data in a graph; images can be enlarged a maximum of 12x\*.

\* Resolution of the enlarged section is reduced.

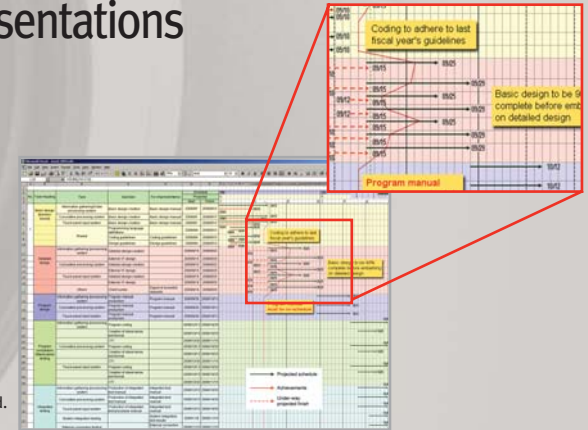

### Spot

Highlights a portion of the image on the screen; the spotlight can be made larger or smaller and moved anywhere on the screen.



### Freeze

Freeze-frame function lets you freeze the on-screen display for pauses in the presentation, such as changing PC connections or checking the subsequent image file.



## Super-High (SXGA+) Resolution

SXGA+ can project 3.1 times the display area of SVGA and 1.9 times the area of XGA to clearly display large amounts of detailed information, such as simultaneous projection of multiple PC windows (SX6, SX60, SX50 only).

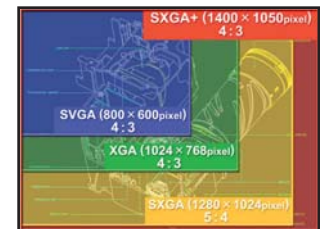



## Guide Functions

The SX6, SX60 and X600 display guide messages in an on-screen window, providing feedback on invalid operations and set-up tips. The same window also introduces auto set-up and Off & Go functions when power is switched on or off.

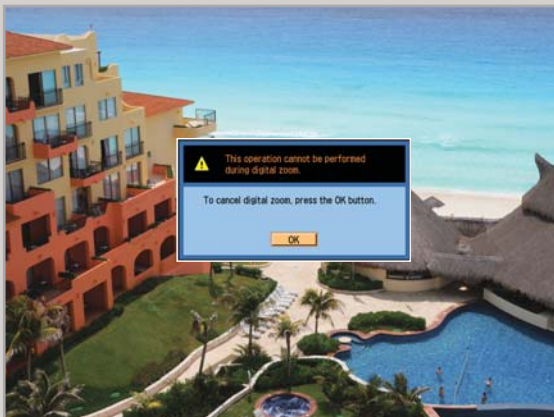

## Canon Throw Distance Chart

### 4:3 Aspect Ratio

SX6, SX60, X600						
Projector Screen Size	40"	80"	100"	150"	200"	300"
Screen Size – horizontally	2'8"	5'4"	6'8"	10'0"	13'4"	20'0"
Projection distance (shortest to longest)	3'11" – 6'5"	7'9" – 12'11"	9'8" – 16'2"	14'7" – 24'4"	19'6" – 29'6"	29'4" – 29'6"
SX50						
Projector Screen Size	40"	80"	100"	150"	200"	300"
Screen Size – horizontally	2'8"	5'4"	6'8"	10'0"	13'4"	20'0"
Projection distance (shortest to longest)	3'11" – 6'6"	7'10" – 13'1"	9'10" – 16'4"	14'10" – 24'7"	19'10" – 29'10"	29'9" – 29'10"

### 16:9 Aspect Ratio

SX6, SX60, X600						
Projector Screen Size	40"	80"	100"	150"	200"	300"
Screen Size – horizontally	2'11"	5'10"	7'3"	10'11"	14'6"	N/A
Projection distance (shortest to longest)	4'2" – 7'0"	8'5" – 14'1"	10'7" – 17'8"	15'11" – 26'6"	21'3" – 29'6"	N/A
SX50						
Projector Screen Size	40"	80"	100"	150"	200"	300"
Screen Size – horizontally	2'11"	5'10"	7'3"	10'11"	14'6"	N/A
Projection distance (shortest to longest)	4'3" – 7'1"	8'7" – 14'3"	10'9" – 17'10"	16'2" – 26'10"	21'7" – 29'10"	N/A

## Select the Projector Right for Your Application

	SX6	SX60	SX50	X600		
Markets	Business	█	█	█	█	
	Government	█	█	█	█	
	Education	█	█	█	█	
	Exhibits	█	█	█	█	
	Trade Shows	█	█	█	█	
	Hotels	█	█	█	█	
	Retail	█	█	█	█	
	Malls	█	█	█	█	
	Publishing	█	█	█	█	
	Design	█	█	█	█	
	Photography	█	█	█	█	
	Medical	█	█	█	█	
	CAD Engineering	█	█	█	█	
	Structural Design	█	█	█	█	
	Architecture	█	█	█	█	
	Applications	Presentations	█	█	█	█
		Seminars	█	█	█	█
Displays		█	█	█	█	
Lectures		█	█	█	█	
Documentation		█	█	█	█	
Information		█	█	█	█	
Visual Artwork		█	█	█	█	
Color Matching		█	█	█	█	
Entertainment		█	█	█	█	
Home Cinema		█	█	█	█	

## Kit Contents

Remote Control



Soft Case



Computer Cable (DVI-VGA)



USB Cable



Component Video Adapter Cable



Power Cord



# Product Specifications

## Product

REALiS SX6

REALiS SX60

REALiS SX50

REALiS X600

Product		REALiS SX6	REALiS SX60	REALiS SX50	REALiS X600	
Basics	Imaging Device	0.7" Reflective LCD panels (LCoS) x 3				
	Aspect ratio	4:3				
	Native Resolution	SXGA+	SXGA+	SXGA+	XGA	
	Brightness	3500 ANSI Lumens	2500 ANSI Lumens	2500 ANSI Lumens	3500 ANSI Lumens	
Optics	Uniformity	88%	88%	85%	88%	
	Contrast	1000:1	1000:1	1000:1	1000:1	
	Keystone	Vertical	+/- 20 degrees (Auto/Manual)		+/- 20 degrees(Manual)	+/- 20 degrees (Auto/Manual)
		Horizontal	+/- 20 degrees(Manual)			
Image Adjustments	Projection lens	F1.85 - 2.5 , f=21.7 - 35.8 mm		F1.85 - 2.5 f=22.0 - 37.0 mm	F1.85 - 2.5 f=21.7 - 35.8 mm	
	Lens shift	9:1, Fixed				
	Zoom	1.7x Powered , 12x Digital		1.7x Manual, 12x Digital	1.7x Powered , 12x Digital	
	Focus	Powered (Auto/Manual)		Manual	Powered (Auto/Manual)	
	Screen size	40" - 300"				
	Projection distance coverage	3.9 - 29.5ft (1.2 - 9m) / 100": 9.8 - 16.1ft (3.0 - 4.9m)				
	Throw Ratio	1.46 – 2.43:1		1.48 – 2.45:1	1.46 – 2.43:1	
Input Signals	Color Mode	Adobe RGB, sRGB, Presentation, Standard, Movie & Photo	sRGB, Presentation, Standard, Movie, Home Cinema	sRGB, Presentation, Standard, Cinema	sRGB, Presentation, Standard, Movie	
	Color Adjust	Dynamic Gamma, 6-axis (RGBCMY) Color Adjustment				
	Wall Correction	Auto/Manual		Manual	Auto/Manual	
	Mounting	Ceiling/Rear/Ceiling and Rear				
	Tilt Angle	Adjusting feet up to 10 degrees				
Terminals	Analog PC input	UXGA/SXGA+WXGA/SXGA/XGA/SVGA/VGA		UXGA/SXGA+ /SXGA/XGA/ SVGA/VGA	UXGA/SXGA+WXGA/SXGA XGA/ SVGA/VGA	
	Digital PC input	SXGA+ /SXGA/WXGA/XGA SVGA/VGA		SXGA+ /SXGA/XGA SVGA/VGA	XGA/SVGA/VGA	
	Scanning frequency	H:15 - 100 kHz , V: 50 - 100 Hz, Dot clock: 170 MHz		H:15 - 80 kHz , V: 50 - 100 Hz, Dot clock: 170 MHz	H:15 - 100 kHz , V: 50 - 100 Hz, Dot clock: 170 MHz	
	Video/S-video input	NTSC/PAL/SECAM/NTSC4.43/PAL-M/PAL-N				
	Component input	1080i/1035i/720p/575p/480p/575i/480i				
	Digital video input	1080i/1035i/720p/575p/480p				
Build-in Speaker	Input	Digital PC input/Analog PC input/Digital Video input				
	Output	Analog PC input /Component input/SCART input				
		Video input				
		S-Video input				
Control Terminal	Stereo audio input					
Network	Analog PC output					
Lamp	Type	270W NSH	180W NSH	200W NSH	270W NSH	
	Lamp Life (Quiet/Normal)	2000/1500 Hours	4000/2500 Hours	2000/1500 Hours	2000/1500 Hours	
Remote Control	Sensor	Wireless Infrared, Front/Back		Wireless Infrared, Front	Wireless Infrared, Front/Back	
	Mouse Control	USB				
Ratings	Fan Noise (Normal/Quiet)	35/31 dB	30/27 dB	37dB/34 dB	35/31 dB	
	Power	Consumption (Normal/Stand-by)	355W/290W/7W	250W/225W/7W	290W/240W/6W	355W/290W/7W
		Voltage	AC 100 to 240V , 50/60Hz			
	Temperature	Operating	41 to 95 F (5 to 35 C)			
		Storage	-22 to 140 F (-30 to 60 C), 5%RH-90%RH			
Dimensions ( W x D x H )	8.9 x 13.2 x 4.5 in. (226 x 336 x 114 mm)		11.2 x 3.8 x 11.3 in. (284 x 96 x 286 mm)	8.9 x 13.2 x 4.5 in. (226 x 336 x 114 mm)		
Weight	10 .4 lbs (4.7 kg)		10 .1 lbs (4.6 kg)	8.6 lbs (3.9 Kg)		

## Optional Accessories



Replacement Lamp  
RS-LP02 (SX6, X600)  
RS-LP03 (SX60)  
RS-LP01 (SX50)



Ceiling Mount  
RS-CL01 (SX50)  
RS-CL06 (SX60, SX6,X600)



Ceiling Plate  
RS-CL02



Ceiling Pipe  
RS-CL03 (14.17 in.)  
RS-CL04 (21.65 in.)  
RS-CL05 (29.92 in.)



Network Adapter  
RS-NA01

RS-232C Cable RS-CA01

**1-800-OK-CANON**  
**WWW.CANONPROJECTORS.COM**

Canon U.S.A., Inc.  
One Canon Plaza  
Lake Success, NY 11042, U.S.A.

Canon Canada Inc.  
6390 Dixie Road, Mississauga  
Ontario L5T 1P7 Canada

Canon Mexicana, S. DE R.L. DE C.V.  
Blvd. M. A. Camacho No. 138, Piso PB  
15, 16 y 17, Col. Lomas de Chapultepec,  
C.P. 11000 México, D.F. México

Canon Latin America, Inc.  
703 Waterford Way, Suite 400  
Miami, FL 33126, U.S.A.

\*Systems Contractor News, October 2005 in Realis SX50 review.  
Errors and omissions excepted. Weight and dimensions are approximate. Specifications subject to change without notice. Projected images simulated.

**Canon**  
**image*ANYWARE***

© 2006 Canon U.S.A., Inc. All rights reserved.  
Canon is a registered trademark of Canon Inc.  
in the United States and may also be a registered  
trademark in other countries. IMAGE*ANYWARE*  
is a trademark of Canon.