

USER MANUAL

MODEL:

VS-622DT

6x2 HDMI/HDBT Audio Matrix Switcher

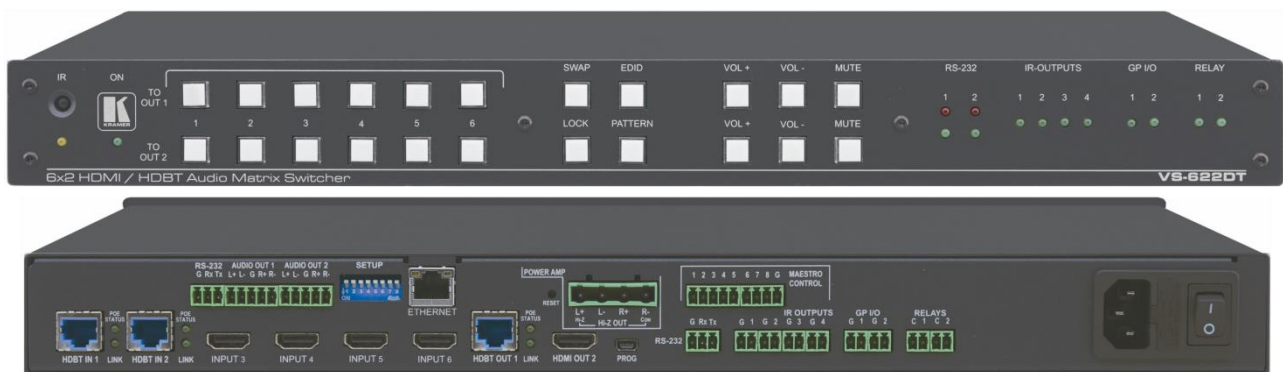

Contents

Introduction	1
Getting Started	1
Overview	2
Typical Applications	3
Controlling your VS-622DT	4
Defining VS-622DT	5
Installing in a Rack	7
Connecting VS-622DT	8
Connecting the Audio Outputs	10
Connecting to VS-622DT via RS-232	10
Connecting VS-622DT via the Ethernet Port	11
Operating VS-622DT via Front Panel Buttons	14
Capturing the EDID	14
Using the Web Pages	15
Switching and Setting Ports	17
Managing EDID	23
Copying EDID from an Output to an Input	23
Copying EDID from an Input to an Input	26
Copying EDID from the Default EDID to an input	28
Loading a Customized EDID from a File	28
Changing the Device Settings	29
Saving and Loading Settings	29
Resetting to Factory Default Parameters	30
Managing Ethernet Settings	30
Setting the Date and Time	34
Upgrading the Firmware	35
Setting Authentication	37
Managing IO Gateway Settings	40
Configuring RS-232 Signal Tunneling	40
Setting GPI/O Parameters	42
Setting Relays	47
Configuring Room Automation	48
Viewing General Information	49
Technical Specifications	50
Default Parameters	51
Protocol 3000	52
Understanding Protocol 3000	53
Kramer Protocol 3000 Syntax	54
Protocol 3000 Commands	55

Introduction

Welcome to Kramer Electronics! Since 1981, Kramer Electronics has been providing a world of unique, creative, and affordable solutions to the vast range of problems that confront the video, audio, presentation, and broadcasting professional on a daily basis. In recent years, we have redesigned and upgraded most of our line, making the best even better!

Our 1,000-plus different models now appear in 15 groups that are clearly defined by function: GROUP 1: Distribution Amplifiers; GROUP 2: Switchers and Routers; GROUP 3: Control Systems; GROUP 4: Format & Standards Converters; GROUP 5: Range Extenders & Repeaters; GROUP 6: Specialty AV Products; GROUP 7: Scalars; GROUP 8: Cables and Connectors; GROUP 9: Room Connectivity; GROUP 10: Mounting and Rack Adapters; GROUP 11: Sierra Video; GROUP 12: Digital Signage; GROUP 13: Audio; GROUP 14: Collaboration; and GROUP 15: KM & KVM Switches.

Getting Started

We recommend that you:

- Unpack the equipment carefully and save the original box and packaging materials for possible future shipment.
- Review the contents of this user manual.



Go to www.kramerav.com/downloads/VS-622DT to check for up-to-date user manuals, application programs, and to check if firmware upgrades are available (where appropriate).

Achieving the Best Performance

- Use only good quality connection cables (we recommend Kramer high-performance, high-resolution cables) to avoid interference, deterioration in signal quality due to poor matching, and elevated noise levels (often associated with low quality cables).
- Do not secure the cables in tight bundles or roll the slack into tight coils.
- Avoid interference from neighboring electrical appliances that may adversely influence signal quality.
- Position your Kramer **VS-622DT** away from moisture, excessive sunlight and dust.



This equipment is to be used only inside a building. It may only be connected to other equipment that is installed inside a building.

Safety Instructions



Caution: There are no operator serviceable parts inside the unit.

Warning: Use only the power cord that is supplied with the unit.

Warning: Do not open the unit. High voltages can cause electrical shock! Servicing by qualified personnel only.

Warning: Disconnect the power and unplug the unit from the wall before installing.

Recycling Kramer Products

The Waste Electrical and Electronic Equipment (WEEE) Directive 2002/96/EC aims to reduce the amount of WEEE sent for disposal to landfill or incineration by requiring it to be collected and recycled. To comply with the WEEE Directive, Kramer Electronics has made arrangements with the European Advanced Recycling Network (EARN) and will cover any costs of treatment, recycling and recovery of waste Kramer Electronics branded equipment on arrival at the EARN facility. For details of Kramer's recycling arrangements in your particular country go to our recycling pages at www.kramerav.com/support/recycling.

Overview

Congratulations on purchasing your Kramer **VS-622DT 6x2 HDMI/HDBT Audio Matrix Switcher**. **VS-622DT** is an all-in-one 4K@60Hz (4:2:0) presentation system with 6x2 HDMI™/HDBaseT® matrix switching, control gateway, PoE, power amplifier, and Maestro room automation.

The unit reclocks and equalizes the signals and can route any input to the HDMI or the HDBaseT output or to both outputs simultaneously. It supports resolutions up to 4K@60Hz (4:2:0).

VS-622DT is also a control gateway that can send control signals over the Ethernet or HDBT LINE with control ports that include: RS-232, four IR, two GPI/O, and two relays to control a wide variety of AV devices. The unit provides power to PoE compatible devices.

VS-622DT provides exceptional quality, advanced and user-friendly operation, and flexible control.

Exceptional Quality

- Max. Data Rate – 10.2Gbps (3.4Gbps per graphics channel).
- Max. Resolution – 4K@60Hz (4:2:0).
- Provides Power (PoE) on all HDBaseT ports to compatible devices.
- HDBaseT Data Tunneling – Supports Ethernet tunneling, as well as bidirectional tunneling for RS-232 and IR control.
- HDBaseT Extension Reach – Up to 100m at 4K @60Hz (4:2:0), up to 130m (430ft) at full HD (1080p @60Hz 36bpp), up to 180m (590ft) at ultra-mode and full HD (1080p @60Hz 24bpp). For optimum range and performance, use recommended Kramer cables.
- HDCP compliant.
- HDMI Support – 3D, Deep Color, x.v.Color™, Lip Sync, Dolby® TrueHD, Dolby Digital Plus, DTS-HD®, and 7.1 PCM.
- EDID Capture – Copies and stores the EDID from a display device to non-volatile EDID storage.
- True video clock detection.

- Kramer ReKlocking™ & Equalization Technology – Rebuilds the digital signal to travel longer distances.
- Static or dynamic DHCP IP addressing.

Advanced and User-friendly Operation

- Simple and Powerful Maestro 1.5 Room Automation – Intuitive user interface enables you to fully automate your meeting room elements. Configure lights, shades, devices and more to be activated by an extensive range of triggers, including scheduling, input/output connectivity, routing, and button pressing. By minimizing user intervention, Maestro room automation saves meeting prep time and minimizes human error before presentations.
- Advanced Auto AV Switching – Optional independent (breakaway) audio routing of embedded HDMI to two balanced audio ports.
- Audio Extraction (De-embedding) – Select the audio signals from 2 of the 6 inputs (2 HDBaseT + 4 HDMI) to be extracted. The extracted signals are output through the two balanced analog audio outputs. In addition, one of the extracted audio signals can be output to the power amplifier
- Programmable Step-In over HDMI Functionality – When used in conjunction with compatible step-in devices, such as the **SID-X3N** and **DIP-31** (using an HDMI cable that supports HEC, the HDMI Ethernet Channel).
- Lock Button – Prevents unwanted tampering with the front panel.
- Internal pattern generator.
- Embedded Web Pages – Provide remote configuration and operation.
- Flexible Control Options – Front panel buttons, IR remote (included), RS-232, Ethernet, embedded web pages, Kramer protocol 3000 support.
- USB Port – For upgrading firmware.

Flexible Connectivity

- 2 HDBT and 4 HDMI inputs.
- 1 HDBT and 1 HDMI output.
- 2 stereo balanced audio outputs.
- Built-in Power Amplifier – 1x120W @70V/100V & 2x60W @4/8Ω.
- Control gateway with RS-232, IR, GPI/O and relay ports.

Typical Applications

VS-622DT is ideal for the following typical applications:

- Small to mid-sized boardrooms, meeting rooms and executive meeting spaces.
- Houses of worship.
- Lecture halls and classrooms.

- Any application where high quality conversion and switching of multiple and different video signals to graphical data signals is required for display or projection purposes.

Controlling your VS-622DT

Control your VS-622DT directly via the front panel buttons (see [Operating VS-622DT via Front Panel Buttons](#) on page [14](#)), or:

- By RS-232 serial commands transmitted by a touch screen system, PC, or other serial controller (see [Connecting to VS-622DT via RS-232](#) on page [10](#)).
- Remotely, using the infrared remote-control transmitter.
- Via the Ethernet using built-in user-friendly Web pages (see [Using the Web Pages](#) on page [15](#)).

Defining VS-622DT

This section defines VS-622DT.

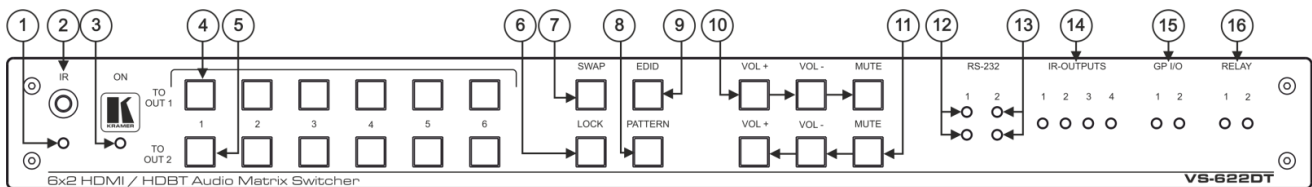

Figure 1: VS-622DT 6x2 HDMI/HDBT Audio Matrix Switcher Front Panel

#	Feature	Function
①	IR LED	Lights yellow when the unit accepts IR remote commands.
②	IR Receiver	Receives signals from the remote-control transmitter.
③	ON LED	Lights when the unit is powered.
④	TO OUT 1	Press to select an input to switch to OUT 1 (from 1 to 6).
⑤	TO OUT 2	Press to select an input to switch to OUT 2 (from 1 to 6).
⑥	LOCK Button	Press and hold for about 2 seconds to lock/unlock the front panel to prevent unintentional operation.
⑦	SWAP Button	Press to swap between audio outputs.
⑧	PATTERN Button	Press to activate the test pattern generator. When the generator is active, press one of the input buttons to select a test pattern.
⑨	EDID Button	Press to capture the EDID.
⑩	Output 1 Audio Buttons	VOL +: Increase output 1 volume. VOL -: Decrease output 1 volume. MUTE: Mute output 1 audio signal.
⑪	Output 2 Audio Buttons	VOL +: Increase output 2 volume. VOL -: Decrease output 2 volume. MUTE: Mute output 2 audio signal.
⑫	HDBT RS-232 LEDs	Indicates data transmission between a controller and a device connected to the transmitter via HDBT OUT 1: TX 1: Lights green when data is transmitted via HDBT OUT 1. RX 1: Lights red when data is received on HDBT OUT 1.
⑬	External (Controller) LEDs	Indicates data transmission via the RS-232 port (item 29) to the VS-622DT: TX 2: Lights green when data is transmitted on the RS-232 port. RX 2: Lights red when data is received on the RS-232 port.
⑭	IR OUTPUT LEDs (1 to 4)	Lights green when the relevant IR port transmits data.
⑮	GPI/O LEDs (1 to 2)	Lights green when the port is triggered.
⑯	RELAY LEDs (1 to 2)	Lights green when the relay is closed.

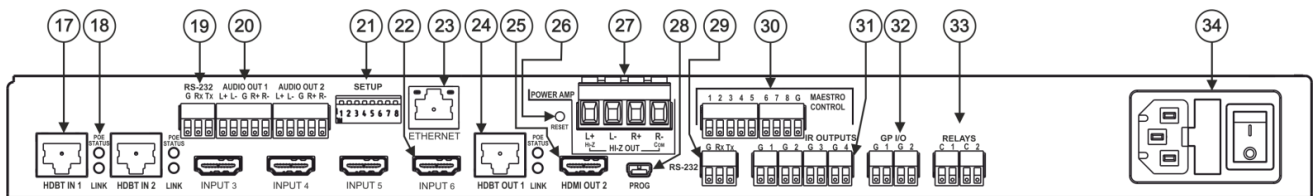

Figure 2: VS-622DT 6x2 HDMI/HDBT Audio Matrix Switcher Rear Panel

#	Feature	Function
17	HDBT IN 1 RJ-45 Connectors (1 to 2)	Connect to an HDBT transmitter (for example, TP-580Txr).
18	POE STATUS and LINK LEDs	Light when PoE is available and an HDBaseT link is established (HDBT IN 1, HDBT IN 2 and HDBT OUT 1).
19	Control RS-232 3-pin Terminal Block	Connect to the serial controller to control the device.
20	AUDIO OUT Balanced Stereo Audio 5-pin Terminal Block Connectors (1 to 2)	Connect to an analog audio acceptor.
21	SETUP DIP-switches	Use to set the device behavior.
22	INPUT HDMI™ Connectors (3 to 6)	Connect to HDMI sources.
23	ETHERNET RJ-45 Connector	Connect to a remote network controller via a LAN.
24	HDBT OUT1 RJ-45 Connector	Connect to an HDBT receiver (for example, TP-580Rxr).
25	HDMI OUT 2 Connector	Connect to an HDMI acceptor.
26	RESET Switch	Press and hold while powering on the device to reset to factory default parameters.
27	Hi-Z OUT Terminal Block Connectors	Lo-Z – connect stereo output to Lo-Z speakers: L+ and L- to the left speaker; R+ and R- to the right speaker. Hi-Z (70V or 100V) – connect Hi-Z and COM to mono Hi-Z speakers.
28	PROG Mini USB Connector	Connect to a PC to perform a firmware upgrade.
29	RS-232 (G, Rx, Tx) Terminal Block Connector	Connect to an RS-232 controlled device.
30	MAESTRO CONTROL 9-pin Terminal Block Connectors	Connect to configurable buttons (configured via the Automation page), such as the RC-21TB .
31	IR OUTPUT 2-pin Terminal Block Connectors (1 to 4)	Connect to IR blasters/emitters.
32	GPI/O 2-pin Terminal Block Connectors (1 to 2)	Connect to controllable sensors or devices (for example, motion sensors). This port can be configured as a digital input, digital output, or analog input.
33	RELAY 2-pin Terminal Block Connectors (1 to 2)	Connect to a relay controllable device (for example, a motorized projection screen).
34	Mains Power Connector, Fuse, and Switch	Connect to the mains supply.

Installing in a Rack

This section provides instructions for rack mounting **VS-622DT**. Before installing in a rack, verify that the environment is within the recommended range:

- Operation temperature – 0° to 40°C (32 to 104°F).
- Storage temperature – -40° to +70°C (-40 to +158°F).
- Humidity – 10% to 90%, RHL non-condensing.



When installing on a 19" rack, avoid hazards by taking care that:

- It is located within recommended environmental conditions. Operating ambient temperature of a closed or multi-unit rack assembly may exceed ambient room temperature.
- Once rack mounted, enough air will still flow around **VS-622DT**.
- **VS-622DT** is placed upright in the correct horizontal position.
- You do not overload the circuit(s). When connecting **VS-622DT** to the supply circuit, overloading the circuits may have a detrimental effect on overcurrent protection and supply wiring. Refer to the appropriate nameplate ratings for information. For example, for fuse replacement, see the value printed on the product label.
- **VS-622DT** is earthed (grounded) and connected only to an electricity socket with grounding. Pay particular attention when electricity is supplied indirectly (for example, when the power cord is not plugged directly into the wall socket but to an extension cable or power strip). Use only the supplied power cord.

To rack-mount VS-622DT:

1. Attach both rack ears to **VS-622DT**:
Remove the screws from each side of **VS-622DT** (3 on each side), and replace them through the rack ears.
2. Place the rack ears of **VS-622DT** against the rack rails and insert the appropriate screws (not provided) through each of the four holes in the rack ears.

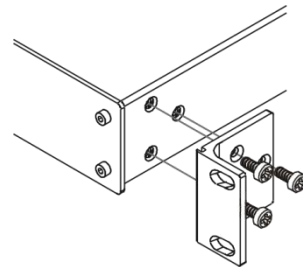

Connecting VS-622DT



Always switch off the power to each device before connecting it to your VS-622DT. After connecting your VS-622DT, connect its power and then switch on the power to each device.



Note that not all the ports are connected in the following example.

To connect the VS-622DT Matrix as illustrated in the example in [Figure 3](#):

1. Connect the HDMI and HDBT sources:
 - An HDMI source (for example, a Blu-ray player) to the HDMI INPUT 6 connector (3 to 6) (22).
 - A transmitter (for example, the Kramer TP-580Txr) to the HDBT IN 1 RJ-45 port (1 to 2) (17).
2. Connect the HDBT and HDMI outputs:
 - The HDBT OUT 1 RJ-45 port (24) to a receiver (for example, the Kramer TP-580Rxr).
 - The HDMI OUT 2 connector (25), to an HDMI acceptor (for example, a display).
3. Connect the audio outputs:
 - The AUDIO OUT 1 terminal block connector (1 to 2) (20) to a balanced audio acceptor (for example, active speakers).
 - The POWER AMP OUT terminal block connector (27) to either Lo-Z or Hi-Z loudspeakers:
 - Lo-Z (4 to 8 ohm):** connect the stereo output to Lo-Z speakers by connecting the left loudspeaker to the “L+” and the “L-” terminal block connectors, and the right loudspeaker to the “R+” and the “R-” terminal block connectors.
 - Hi-Z (70V or 100V):** connect Hi-Z and COM to mono Hi-Z speakers.



Do not ground the loudspeakers.

4. Connect RS-232 3-pin terminal blocks:
 - RS-232 Data (29) – connect directly to control the HDMI output acceptor (for example, a display).
Alternatively, connect to a laptop to control peripheral devices that are connected to transmitters/receivers that connect to the HDBT OUT ports.
 - RS-232 Control (19) – Connect to a laptop to control VS-622DT.

- Connect ETHERNET port (23) to a laptop or network to control **VS-622DT**.



Since **VS-622DT** incorporates an embedded Layer 2 Ethernet switch. We recommend that you only connect this port to the network.

Peripheral devices that are connected to **VS-622DT** via HDBT ports and have Ethernet ports as well, should not be connected to the network and can be used for Ethernet IP clients.

Connecting the Ethernet port of the HDBT transmitters/receivers to the network switch port in conjunction with Ethernet port network connection on the **VS-622DT**, will cause network loops that may cause Ethernet switch network breakdown.

- Connect IR OUT 4 2-pin terminal blocks (1 to 4) (31) to an IR emitter and attach the emitter to a controlled device (for example, a Blu-ray player).
- Connect the GPI/O 2-pin terminal block connector (1 to 2) (32) to an input/output device (for example, a sensor).
- Connect the RELAY 2-pin terminal block connector (1 to 2) (33) to a relay port (for example, a controlled screen).
- Connect the Maestro terminal block connectors (1 to 8) (30) to configurable buttons (for example, the Kramer **RC-21TB**).
- Connect the power cord (34).

We recommend that you use only the power cord that is supplied with this machine.

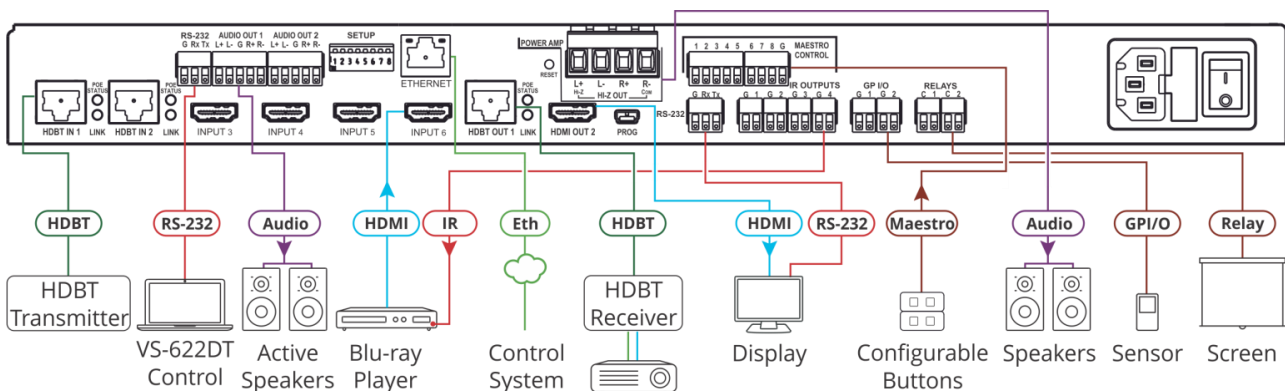
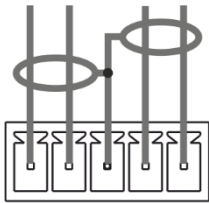

Figure 3: Connecting to the VS-622DT Rear Panel

Connecting the Audio Outputs

The following are the pinouts for connecting the audio outputs (20) to balanced or unbalanced stereo audio acceptors:



L+ L- G R+ R-

Figure 4: Connecting the Output to a Balanced Stereo Audio Acceptor

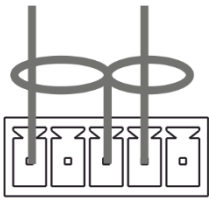

L+ L- G R+ R-

Figure 5: Connecting the Output to an Unbalanced Stereo Audio Acceptor

Connecting to VS-622DT via RS-232

You can connect to the VS-622DT via an RS-232 connection to the Control RS-232 port (19) using, for example, a PC; and connect the second Control RS-232 port (29) to an RS-232 controlled device.

Connect the RS-232 terminal block on the rear panel of the VS-622DT to a PC/controller, as follows (see [Figure 6](#)):

- TX pin to Pin 2.
- RX pin to Pin 3.
- GND pin to Pin 5.

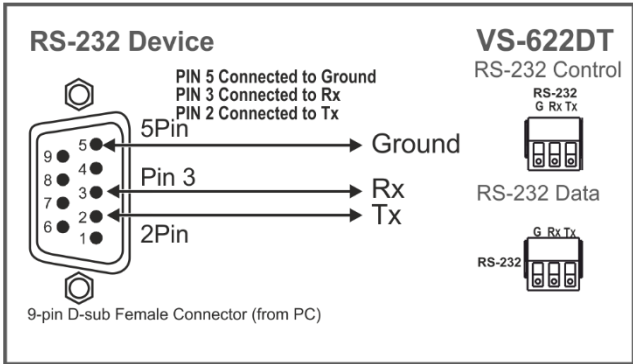

Figure 6: RS-232 Connection

Connecting VS-622DT via the Ethernet Port

You can connect to the VS-622DT via Ethernet using either of the following methods:

- Directly to the PC using a crossover cable (see [Connecting the Ethernet Port Directly to a PC](#) on page 11).
- Via a network hub, switch, or router, using a straight-through cable (see [Connecting the Ethernet Port via a Network Hub or Switch](#) on page 13).



If you want to connect via a router and your IT system is based on IPv6, speak to your IT department for specific installation instructions.

Connecting the Ethernet Port Directly to a PC

You can connect the Ethernet port of the VS-622DT directly to the Ethernet port on your PC using a crossover cable with RJ-45 connectors.



This type of connection is recommended for identifying the VS-622DT with the factory configured default IP address.

After connecting the VS-622DT to the Ethernet port, configure your PC as follows:

1. Click **Start > Control Panel > Network and Sharing Center**.
2. Click **Change Adapter Settings**.
3. Highlight the network adapter you want to use to connect to the device and click **Change settings of this connection**.

The Local Area Connection Properties window for the selected network adapter appears as shown in [Figure 7](#).

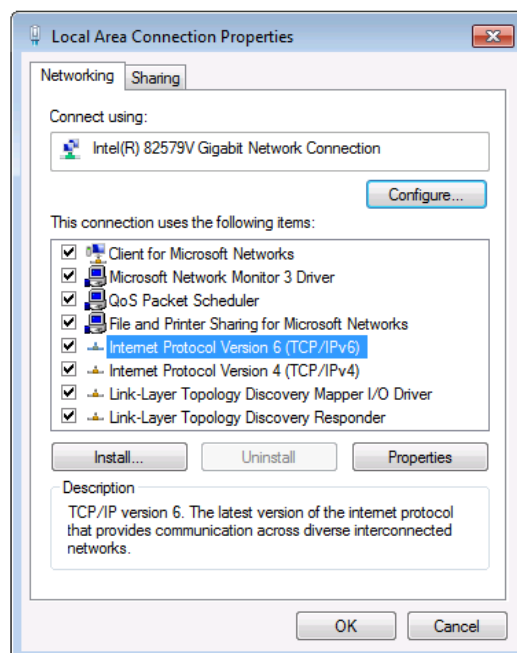

Figure 7: Local Area Connection Properties Window

4. Highlight either **Internet Protocol Version 6 (TCP/IPv6)** or **Internet Protocol Version 4 (TCP/IPv4)** depending on the requirements of your IT system.
5. Click **Properties**.
The Internet Protocol Properties window relevant to your IT system appears as shown in [Figure 8](#) or [Figure 9](#).

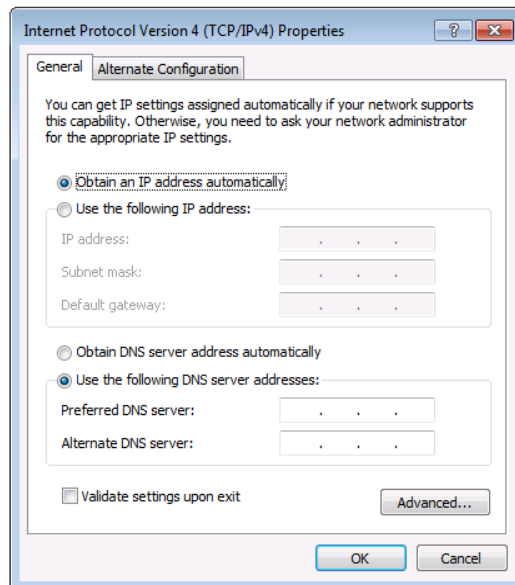

Figure 8: Internet Protocol Version 4 Properties Window

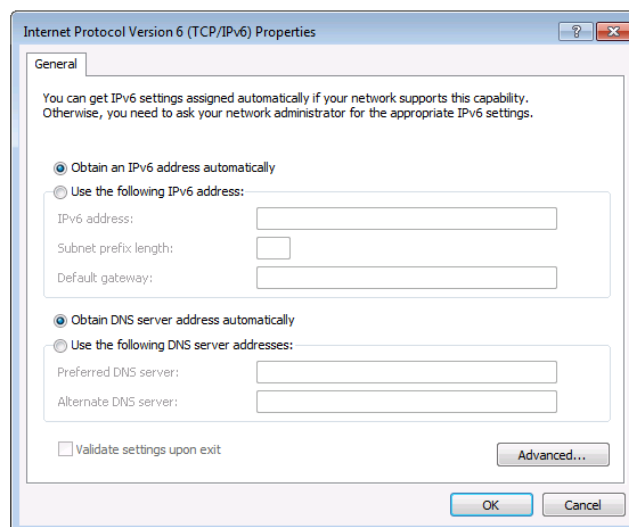

Figure 9: Internet Protocol Version 6 Properties Window

6. Select **Use the following IP Address** for static IP addressing and fill in the details as shown in [Figure 10](#).
For TCP/IPv4 you can use any IP address in the range 192.168.1.1 to 192.168.1.255 (excluding 192.168.1.39) that is provided by your IT department.

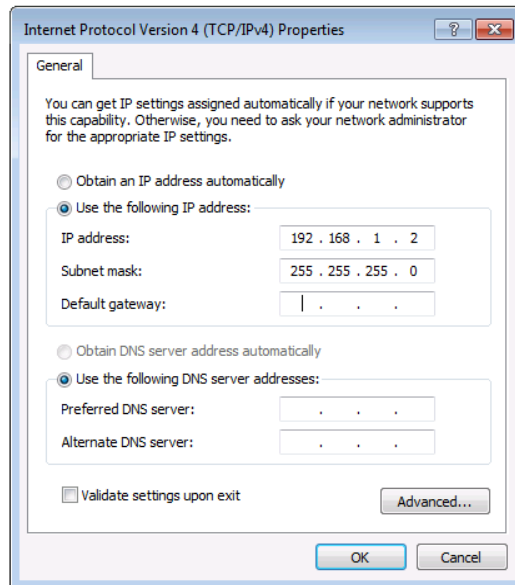

Figure 10: Internet Protocol Properties Window

7. Click **OK**.
8. Click **Close**.

Connecting the Ethernet Port via a Network Hub or Switch

You can connect the Ethernet port of the **VS-622DT** to the Ethernet port on a network hub or using a straight-through cable with RJ-45 connectors.



Since **VS-622DT** incorporates an embedded Layer 2 Ethernet switch, we recommend that this port only is connected to the network.

Peripheral devices that are connected to **VS-622DT** via HDBT ports and have Ethernet ports as well, should not be connected to the network and can be used for Ethernet IP clients.

Connecting the Ethernet port of the HDBT transmitters/receivers to the network switch port in conjunction with Ethernet port network connection on the **VS-622DT**, will cause network loops that may cause Ethernet switch network breakdown.

Control Configuration via the Ethernet Port

To control several units via Ethernet, connect the Master unit (Device 1) via the Ethernet port to the Ethernet port of your PC. Use your PC provide initial configuration of the settings (see [Connecting VS-622DT via the Ethernet Port](#) on page 11).

Operating VS-622DT via Front Panel Buttons

VS-622DT front panel includes the following front panel buttons:

- 12 INPUT selector buttons: 6 buttons to switch inputs to OUT 1 (4) and another 6 to switch inputs to OUT 2 (5).
- LOCK (6), SWAP (7) and PATTERN (8) buttons.
- An EDID (9) button, see [Capturing the EDID](#) on page 14.
- OUT 1 audio level and mute buttons (10).
- OUT 2 audio level and mute buttons (11).

Capturing the EDID

You can acquire the EDID from OUT 1 or OUT 2 and copy it to any or all of the six inputs to be stored in non-volatile memory. You can also reset any or all of the inputs to the default EDID.

To copy the EDID from an output to one or more inputs:

1. Press **EDID**. The device enters the EDID setting mode and the EDID button lights.



If there is no button activity for 10 seconds, the device automatically exits the EDID setting mode to normal operation, the EDID button no longer lights and any changes made are lost.

2. From the To OUT 1 (top) row, press each of the inputs to which you want to copy the EDID from output 1. Each selected input LED lights.
3. From the To OUT 2 (bottom) row, press each of the Inputs into which you want to copy the EDID from output 2. Each selected input LED lights.
4. Press **EDID**.

The EDID changes are saved and the button no longer lights.

To copy the default EDID to one or more inputs:

1. Press **EDID**. The device enters the EDID setting mode and the EDID button lights.
2. For each input to which you want to copy the default EDID, press both the To OUT 1 and To OUT 2 buttons simultaneously. Both top row and bottom row input LEDs light.
3. Press **EDID**.

The EDID changes are saved and the button no longer lights.

Using the Web Pages

The web pages enable you to control the VS-622DT via the Ethernet and perform the following:

- [Switching and Setting Ports](#) on page [17](#).
- [Managing EDID](#) on page [23](#).
- [Changing the Device Settings](#) on page [29](#).
- [Managing IO Gateway Settings](#) on page [40](#).
- [Configuring Room Automation](#) on page [48](#).
- [Viewing General Information](#) on page [49](#).

Before attempting to connect:

- Perform the procedures in [Connecting VS-622DT via the Ethernet Port](#) on page [11](#).
- Ensure that your browser is supported.

The following operating systems and Web browsers are supported:

OS	Version	Browser
Windows	7	IE
		Firefox
		Chrome
		Safari
	10	IE
		Edge
		Firefox
		Chrome
Mac	10.11	Safari
iOS	10.3.2	Safari
Android	N/A	N/A

To browse the VS-622DT Web pages:

1. Open your Internet browser.
2. Type the IP address of the device in the address bar of your browser. For example, the default IP address:



Figure 11: Using the Embedded Web pages – Default IP Address

If the web pages are password protected, the Authentication window appears:

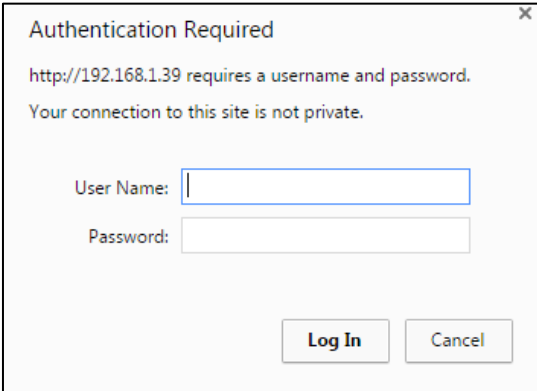

Figure 12: Using the Embedded Web Pages – Authentication Window

- 3. Enter the **User Name** and **Password** (Admin, Admin by-default) and click **OK**. The Routing page appears.

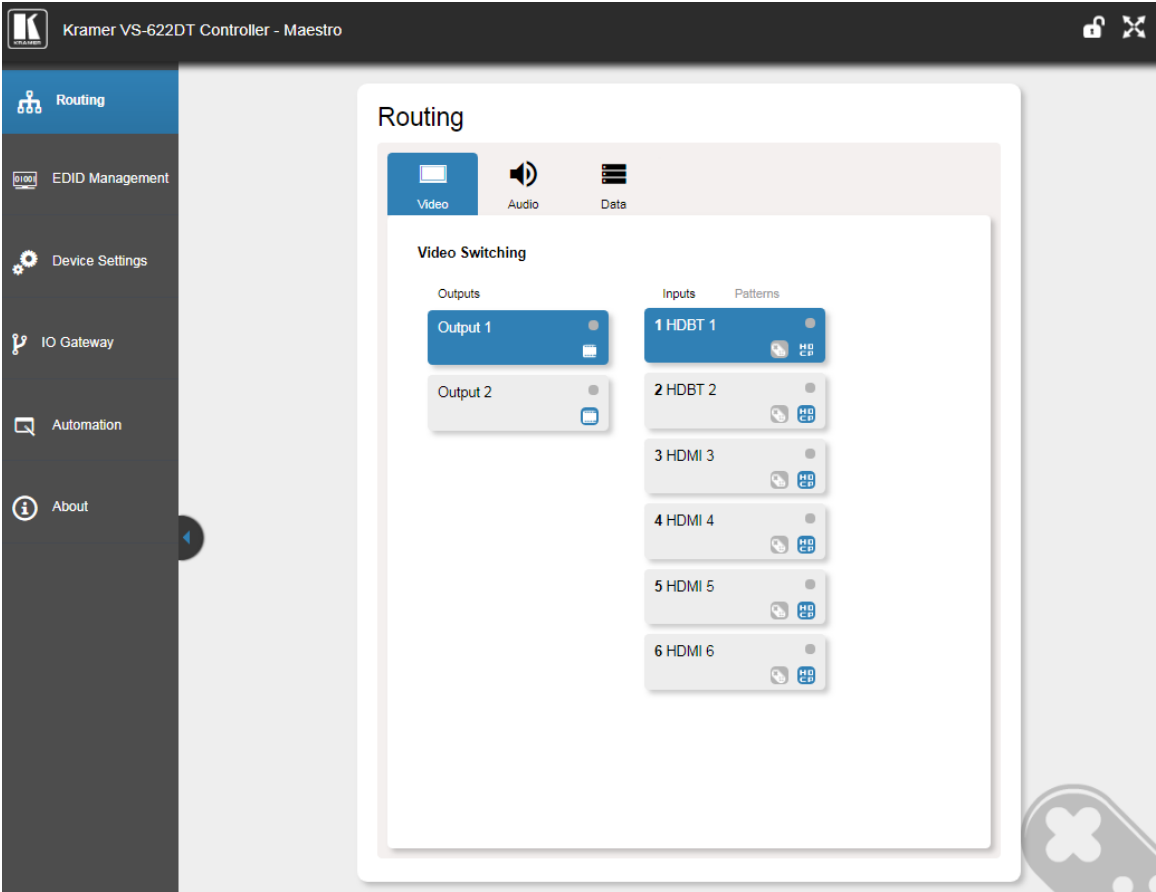

Figure 13: Routing Page with Navigation List on Left

4. Click the desired web page or click the arrow to hide the navigation list.

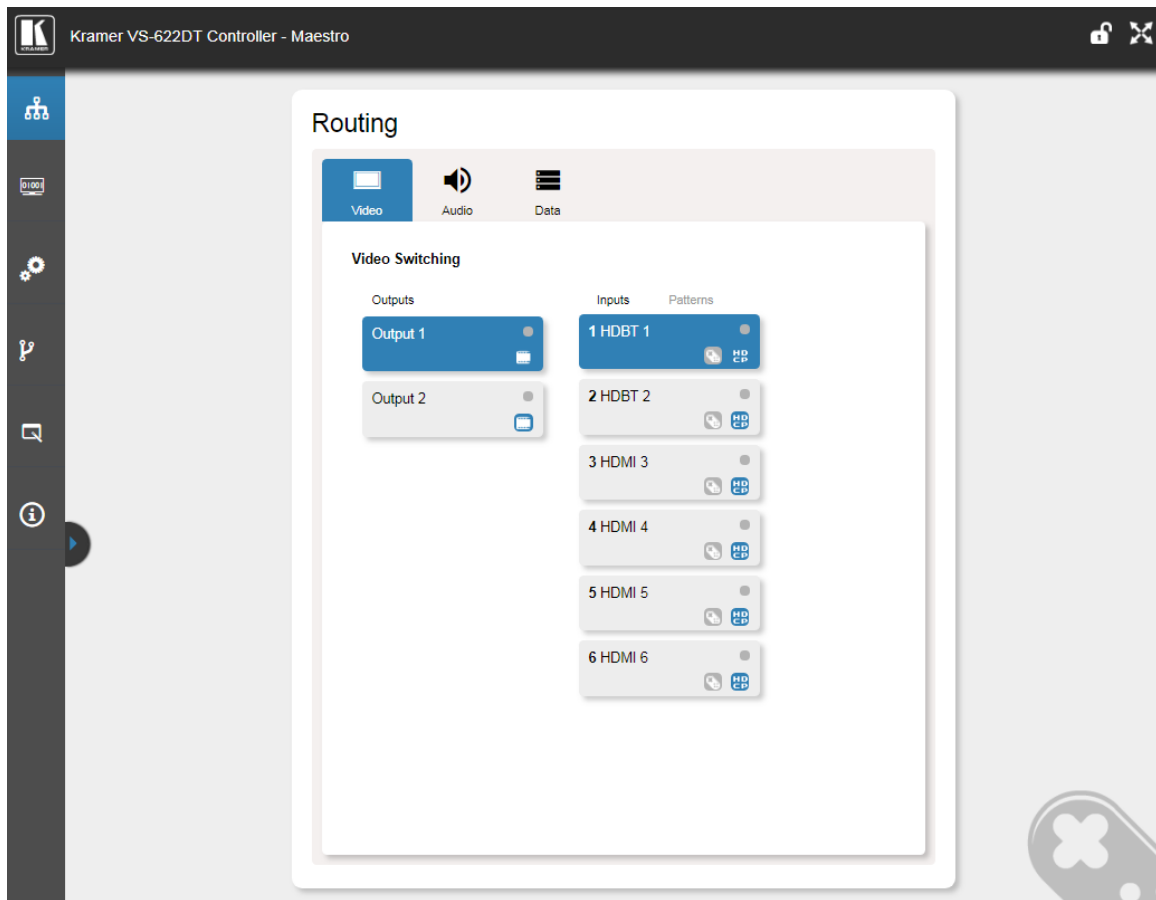

Figure 14: Routing Page – Navigation List Hidden

Switching and Setting Ports

The Routing page enables performing the following functions:

- [Routing Video Inputs](#) on page [18](#).
- [Switching a Pattern to the Outputs](#) on page [20](#).
- [Adjusting Audio Settings](#) on page [21](#).
- [Switching Data](#) on page [22](#).

Routing Video Inputs

Use the Routing page to switch the video inputs to the outputs.

To switch an input to an output:

1. In the Navigation pane, click  **Routing**. The Routing page appears.
2. Click **Video**. The Video tab appears:

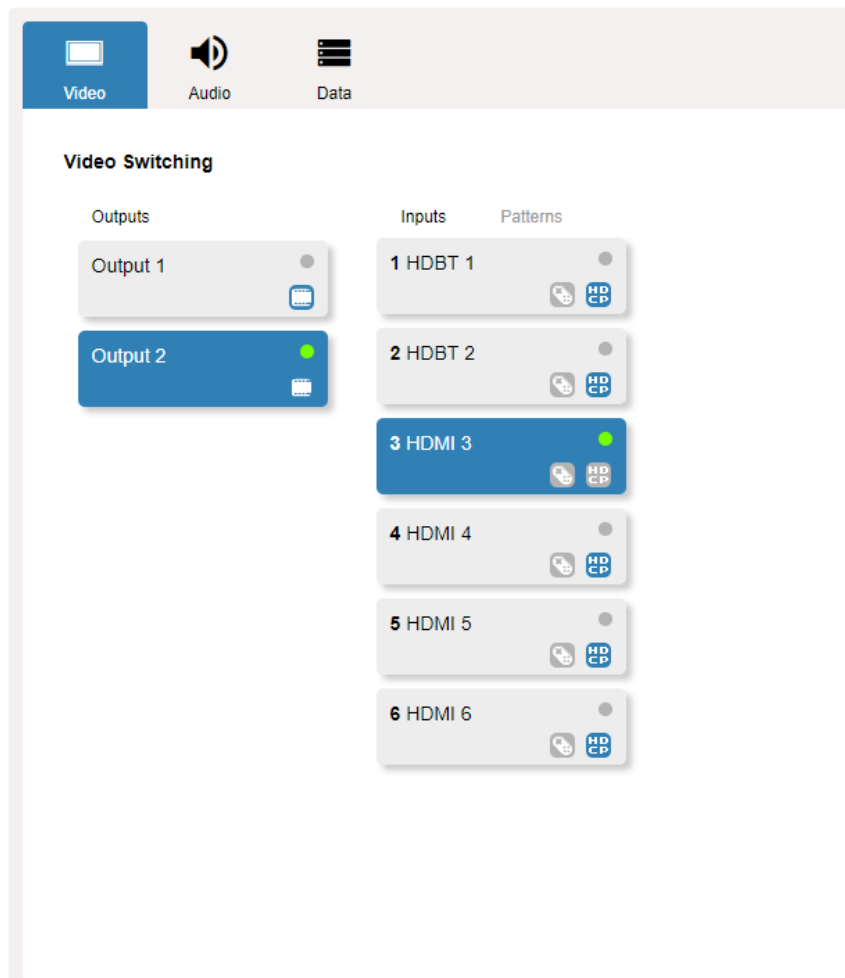





Figure 15: Routing Page – Video Tab

3. Click an Output button (Output 1 or Output 2).
The selected Output button turns blue.
The green dot indicates that an acceptor is connected to the output.
4. Click the Input button to switch to the selected Output. The selected Input button turns blue. That input is switched to the output.
The green dot indicates that a source is connected to the input.

You can:

- Click  on an output button to mute the video output.
- Click  /  on an input button to disable/enable HDCP support.
- Click  on an input button to configure remote device buttons, see [Setting Remote Devices](#) on page 19.

Setting Remote Devices

When the HDMI/HDBT output of a step-in device (for example, the **SID-X3N**, **DIP-30**, **DIP-31** For HDMI inputs and **DIP-20** for HDBT inputs) is connected to an input on the **VS-622DT**, you can program the step-in buttons via automation (see [Configuring Room Automation](#) on page 48) so that when a step-in is carried out (either by pressing the step-in button on the device or by switching to the input on **VS-622DT** that is connected to the step-in device, other actions are executed (such as lights, screen and so on) via the **VS-622DT**.

 When connecting a step-in device (for example, the **DIP-20**) to an HDBT input on the **VS-622DT**, generally you need to set Data switching to **Direct Control** (see [Switching Data](#) on page 22).

Some step-in devices can function even if Data Switching is set to **Follow Video**.

Setting data switching to Direct Control disables RS-232 data routing via the HDBT ports.

To configure remote device buttons:

1. In the Navigation pane, click  **Routing**. The Routing page appears.
2. Click  on an input button.

If a Step-in device is not connected to that input, you can configure the remote button features for when that input is connected in the future.

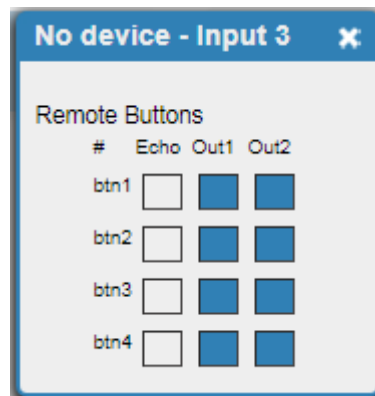

If an Step-in device is connected (for example, the **DIP-30**), The Step-in buttons appear and you can configure the button(s).

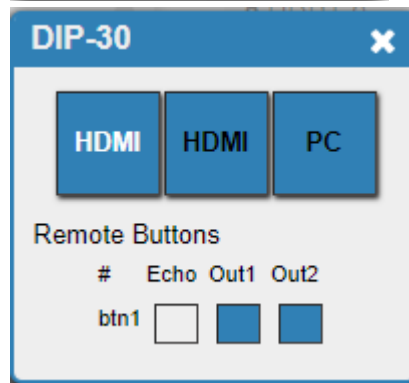

3. You can do the following:
 - Select one of the inputs on the step-in device (visible only when a device is connected) to be switched to the output of that device and routed to the **VS-622DT** input.
 - Check **Echo** to send the ~BTN command to all the control ports. This allows a connected controller to perform a variety of tasks triggered by the user buttons, such as room control (lights, screen, and so on).

- Check **Out1** and/or **Out2** to set the current input to route to OUT 1, OUT 2 or both outputs.



These settings are per input and remain valid even if a remote **DIP-30** is exchanged for another **DIP-30**.

For each button you can activate Echo, Out 1 and Out 2 simultaneously.

Switching a Pattern to the Outputs

You can switch a selected pattern to the outputs.

To switch a selected pattern to the outputs:

1. In the Navigation pane, click **Routing**. The Routing page appears.
2. Click the **Video** tab. Verify that **Patterns** (and not **Inputs**) is selected. The list of patterns appears.
3. Click a pattern.
The selected pattern is switched to both output/s (for example, pattern 1 is switched to outputs 1 and 2).

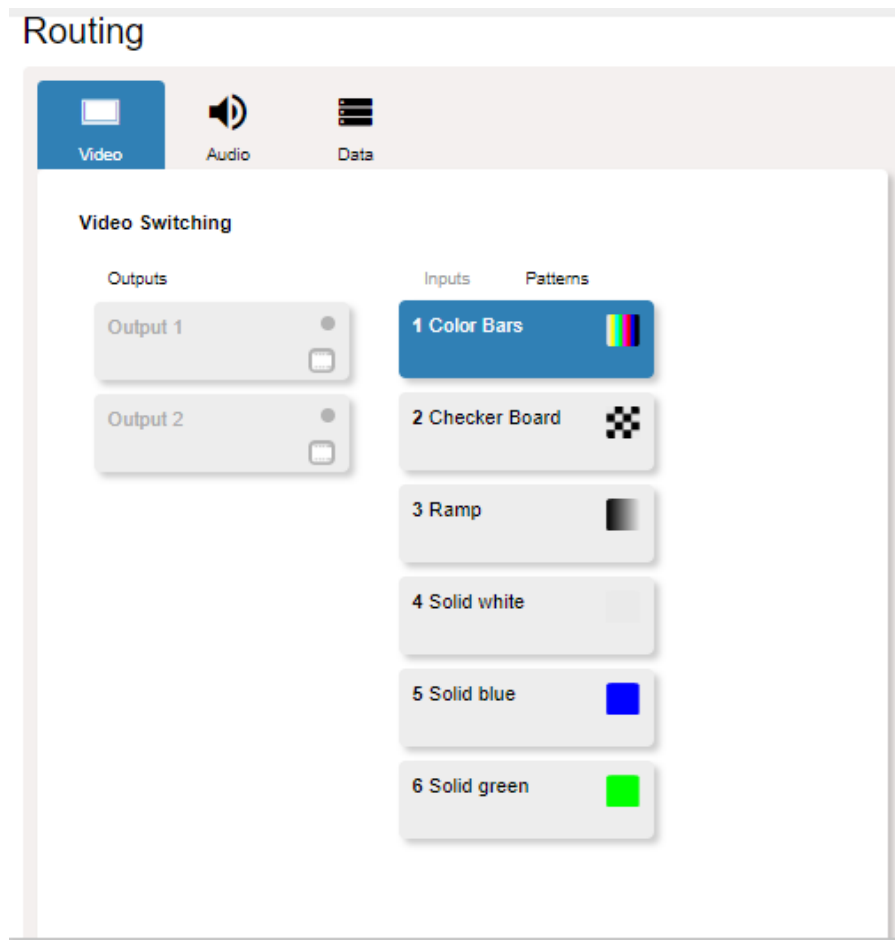



Figure 16: Routing Page – Switching a Pattern to the Outputs

Adjusting Audio Settings

Use the Routing page to adjust the audio settings and swap the audio line out outputs.

To adjust audio settings:

1. In the Navigation pane, click  **Routing**. The Routing page appears.
2. Click **Audio**. The Audio tab appears:

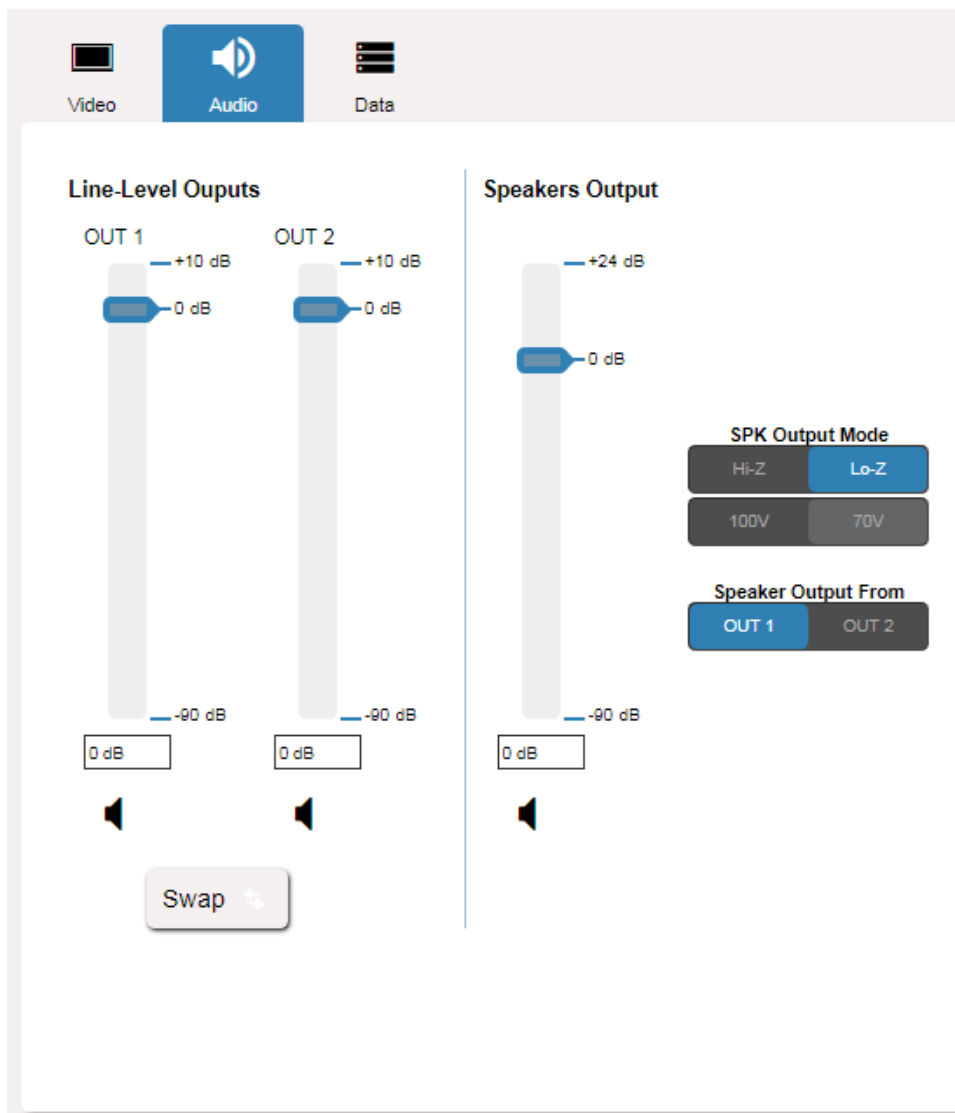



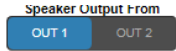

Figure 17: Routing Page – Changing the Output Label

In the **Line-Level Outputs** area, you can:

- Slide the **OUT 1** and **OUT 2** sliders to set the audio level on each output (or type the value below the slider and then click anywhere outside that text box).
- Click **Swap** to swap the audio outputs.
- Click  to mute an output and  to unmute an output.



In the **Speakers Output** area, you can:

- Slide the Speakers Output slider to set the audio level on the speakers (or type the value below the slider and then click anywhere outside the text box).
- Click  to mute the speakers output and  to unmute it.
- Set the output mode to Lo-Z (to connect to stereo Lo-Z speakers) or Hi-Z (to connect to mono Hi-Z speakers – and then select 70V or 100V).
- Click  to take the speaker output audio signal from OUT 1 or OUT 2.

Switching Data

Use the Routing page to set data switching.

To select the HDBT out data source:

1. In the Navigation pane, click  **Routing**. The Routing page appears.
2. Click  **Data**. The Data Switching tab appears:

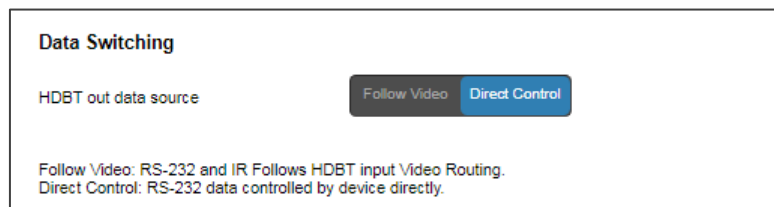

Figure 18: Routing Page – Data Switching

You can:

- Click **Follow Video** for IR and RS-232 to follow the input video routing.
- Click **Direct Control** to let the **VS-622DT** control the RS-232 data.



When connecting a step-in device (for example, the **DIP-20**) to an HDBT input on the **VS-622DT** (see [Setting Remote Devices](#) on page 19), generally you need to set Data switching to **Direct Control**.

Some step-in devices can function even if Data Switching is set to **Follow Video**.

Setting data switching to **Direct Control** disables RS-232 data routing between the HDBT inputs and the HDBT output.

Managing EDID

Use the Managing EDID page to load a customized EDID file from your PC, or to read the EDID from:

- Any of the outputs.
- Any of the inputs.
- The default EDID.

The selected EDID can be copied to selected input/s.



Click **Bytemap** on the right side to view the currently selected EDID source Bytemap.

Copying EDID from an Output to an Input

You can copy the EDID from a selected output to any or all the inputs.

To copy an EDID from an output to an input:

1. In the Navigation pane, click **EDID Management**. The EDID Management page appears.

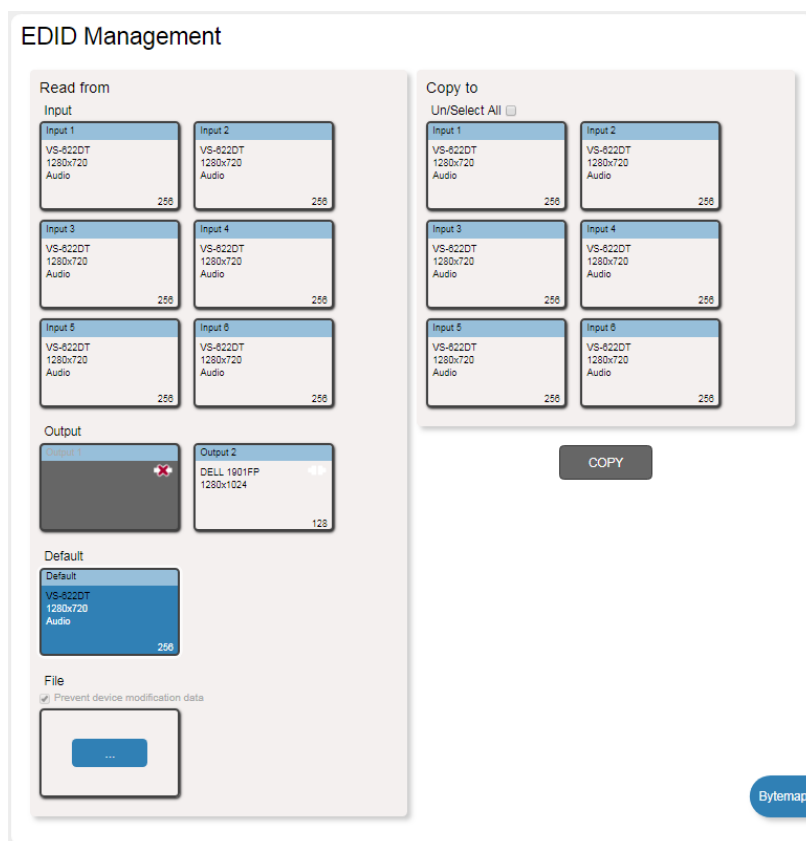

Figure 19: EDID Management Page

2. Click the EDID source (for example, Output 2).

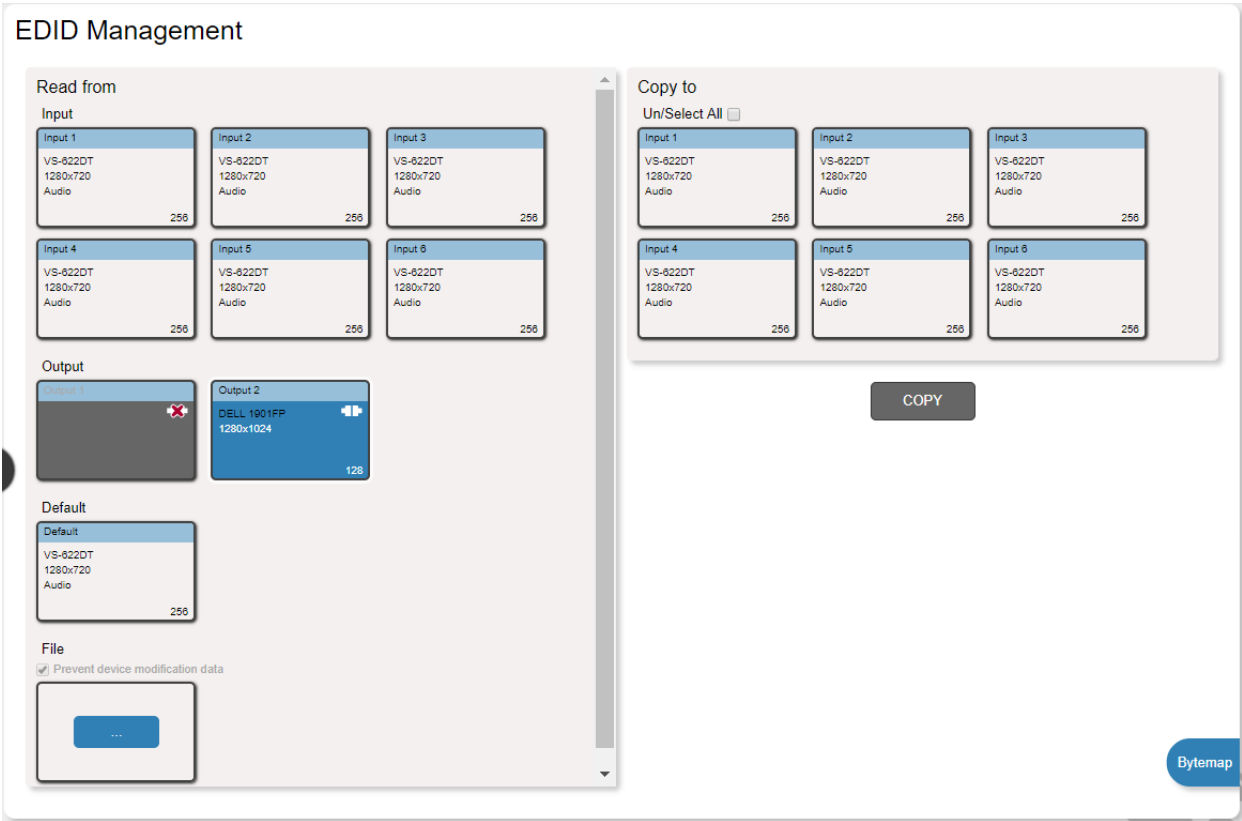
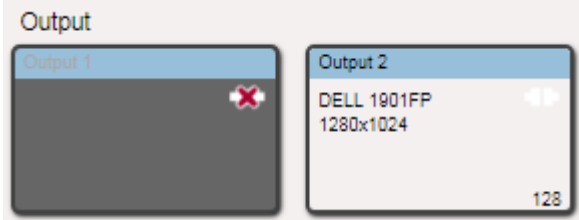

Figure 20: EDID Management Page – Select an EDID Output (Read From)



If you are reading EDID from an output, make sure that that output is connected to an acceptor.

For example, Output 1 is disconnected and Output 2 is connected to an acceptor:



- 3. Select the input/s (or all the inputs) to which the EDID is copied (Inputs 1, 2 and 3 in this example).

EDID Management

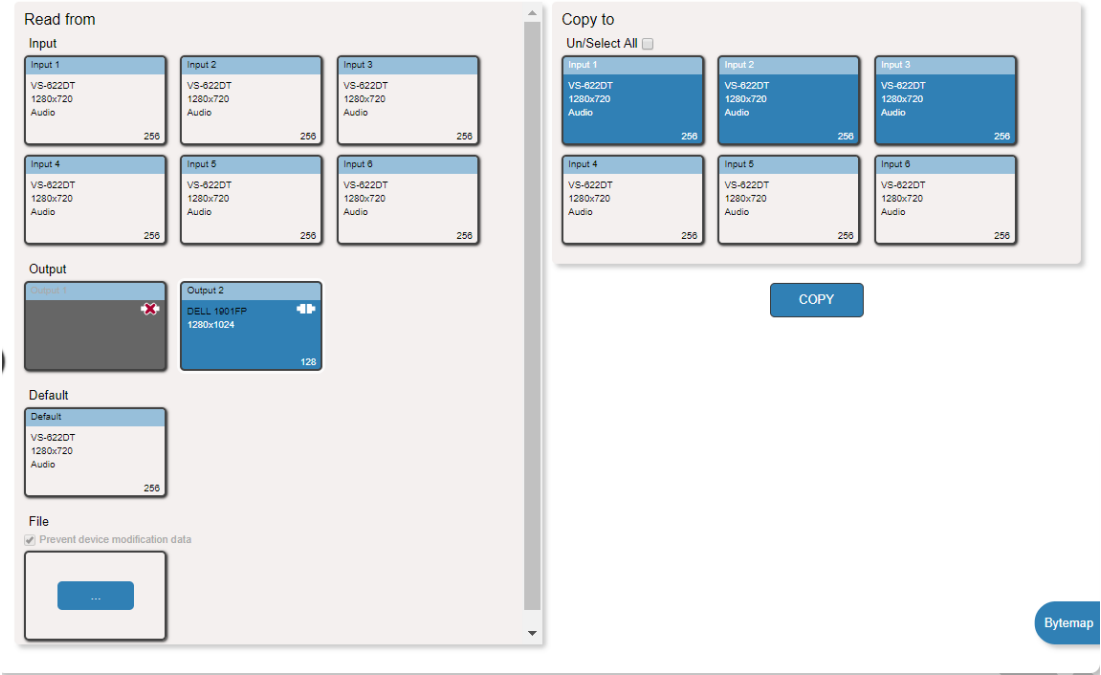

Figure 21: EDID Management Page – Select the Inputs (Copy to)

- 4. Click **COPY**.
The Output 2 EDID is copied to the selected inputs.

EDID Management

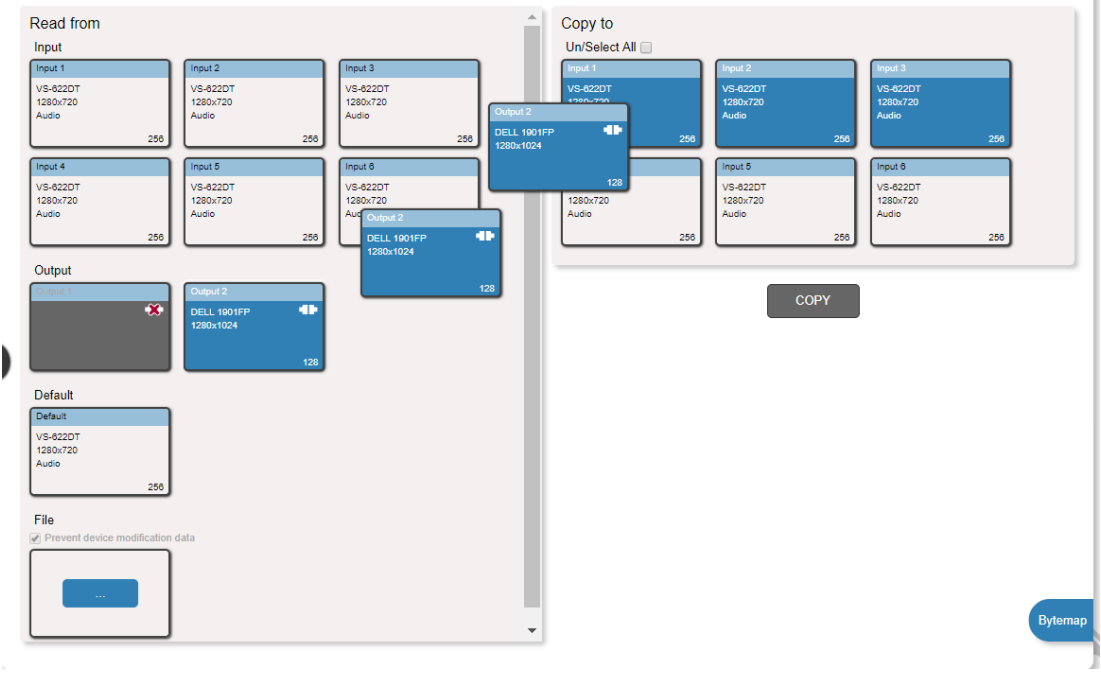

Figure 22: EDID Management Page – EDID Copied

The EDID copy success message appears:

- 5. Click **OK**.

Copying EDID from an Input to an Input

You can copy the EDID from a selected input to any or all the inputs.

To copy an EDID from an input to an input:

- 1. In the Navigation pane, click **EDID Management**. The EDID Management page appears (see [Figure 19](#)).
- 2. Select the EDID source (for example, Input 2).

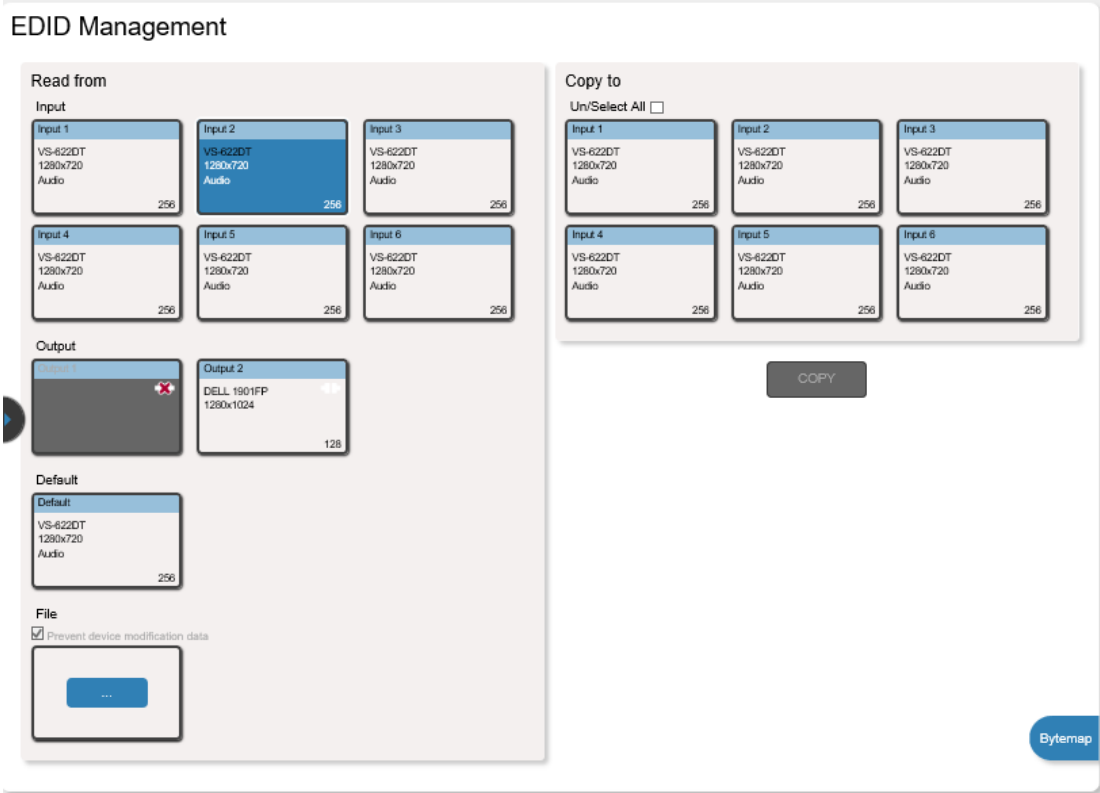

Figure 23: EDID Management Page – Select an EDID Input (Read From)

3. Select the input/s (or all the inputs) to which the EDID is copied (Inputs 2 and 5 in this example).

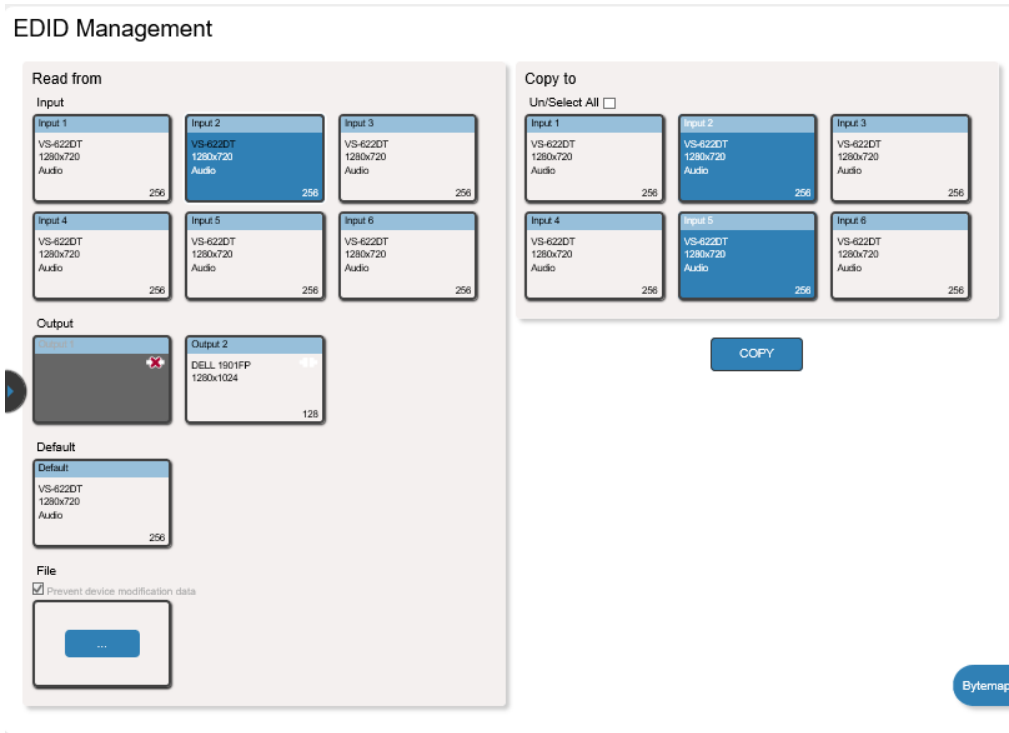

Figure 24: EDID Management Page – Select the Inputs (Copy to)

4. Click **COPY**.
The Input 2 EDID is copied to the selected inputs.

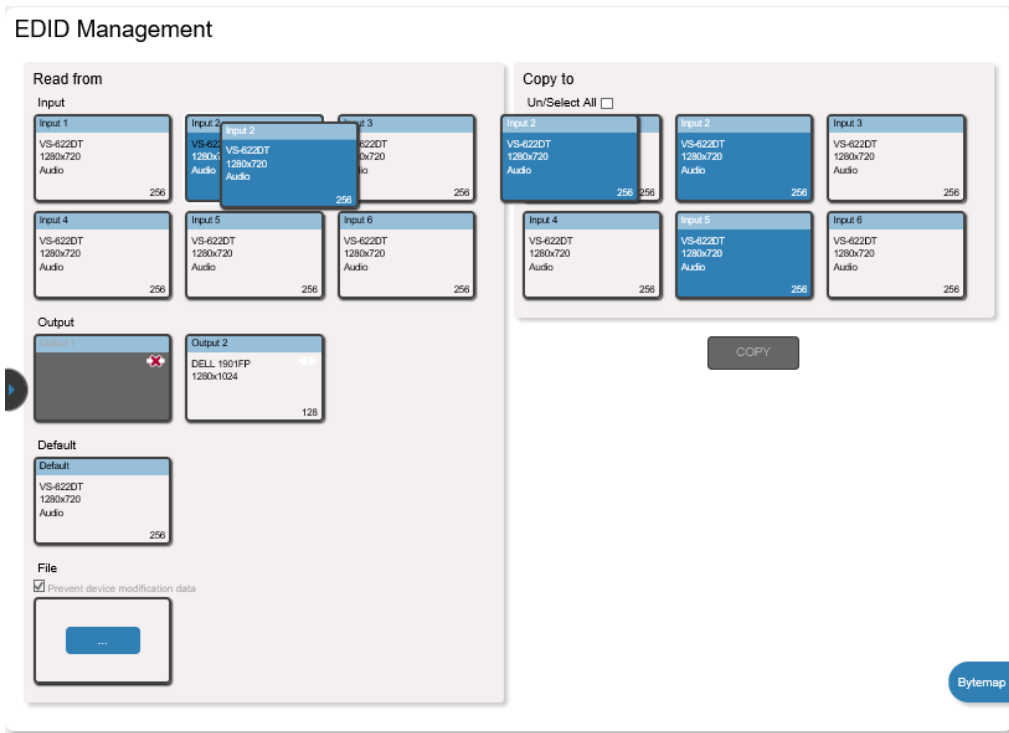

Figure 25: EDID Management Page – EDID Copied

The EDID copy success message appears.

5. Click **OK**.

Copying EDID from the Default EDID to an input

You can copy the default EDID to any or all the inputs.

To copy the EDID from the default EDID:

1. In the Navigation pane, click **EDID**. The EDID Management page appears (see [Figure 19](#)).
2. Click **Default**.
3. Select the input/s (or all the inputs) to which the default EDID is copied.
4. Click **Copy** and follow the instructions on-screen.

Loading a Customized EDID from a File

You can Load a customized EDID from a selected file to any or all the inputs.

To load a customized EDID file:

1. In the Navigation pane, click **EDID**. The EDID Management page appears (see [Figure 19](#)).



Keep the **Prevent device modification data** checked if you wish to prevent any modification of the EDID that the device reads.

2. In the **File** area click "...".
3. Select the EDID file.
4. Select the input/s (or all the inputs) to which the EDID is copied.
5. Click **Copy** and follow the instructions on-screen.

Changing the Device Settings

The Device Settings web page shows the device details such as name, serial number and firmware version and also enables performing the following functions:

- Changing the **Unit Name** (in the General Settings tab) by typing the new name and saving it.
- [Saving and Loading Settings](#) on page 29.
- [Resetting to Factory Default Parameters](#) on page 30.
- [Managing Ethernet Settings](#) on page 30.
- [Setting the Date and Time](#) on page 34.
- [Upgrading the Firmware](#) on page 35.
- [Setting Authentication](#) on page 37.

Saving and Loading Settings

You can save and load the device configuration settings, including automation settings (e.g., ports, actions, scripts and triggers).

To save the current configuration:

1. In the Navigation pane, click **Device Settings**. The General tab in the Device Settings page appears:

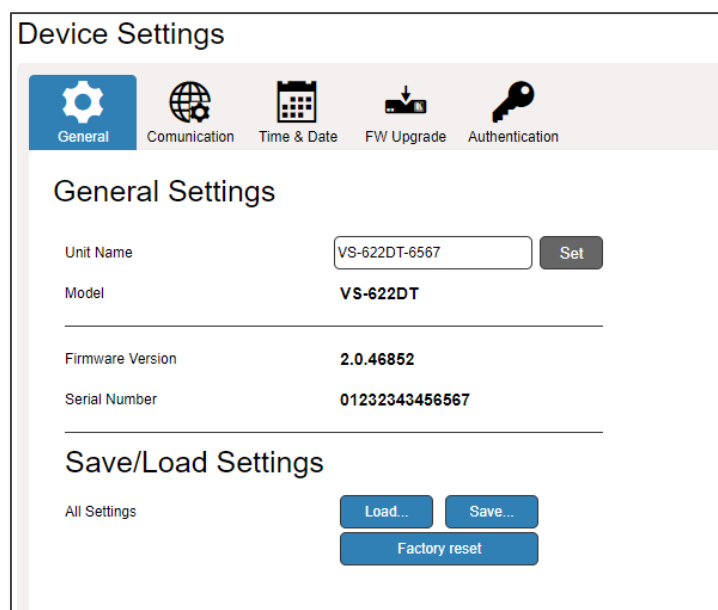

Figure 26: Device Settings Page – General Tab

2. Click **Save**. A progress message appears. When complete, the following message appears:

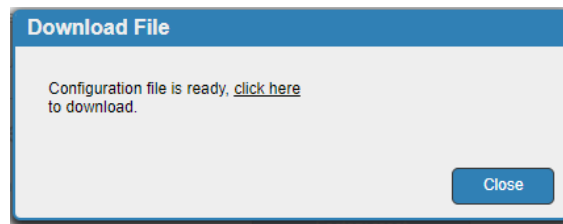

Figure 27: Device Settings Page – Downloading the File

3. Click **click here**.

The file (for example, VS_622DTConfigurationFile.kcd) is downloaded and saved to the Downloads folder.

To load a configuration:

1. In the Navigation pane, click **Device Settings**. The General tab in the Device Settings page appears (see [Figure 26](#)).
2. Click **Load**.
A progress message appears. When the configuration is uploaded to the device, a success message appears.
3. Click **OK**.

The configuration is uploaded to the device.

Resetting to Factory Default Parameters

To reset the device to its default parameters:

1. In the Navigation pane, click **Device Settings**. The Device Settings page appears.
2. In the Save/Load Settings area, click **Factory reset**. A confirmation message is displayed.
3. Click **OK**.

The device resets to its default parameters. The current web session is disconnected and a new session opens with the default IP address.

Managing Ethernet Settings

The Communication tab enables performing the following functions:

- [Changing Ethernet Settings when DHCP is Off](#) on page [31](#).
- [Changing Ethernet Settings when DHCP is On](#) on page [32](#).
- [Setting DHCP to Off](#) on page [33](#).

Changing Ethernet Settings when DHCP is Off

 After changing the **Mask address**, you need to power cycle the **VS-622DT**.

To change the Ethernet settings:

1. In the Navigation pane, click **Device Settings**. The Device Settings page appears.
2. Click the **Communication** tab:

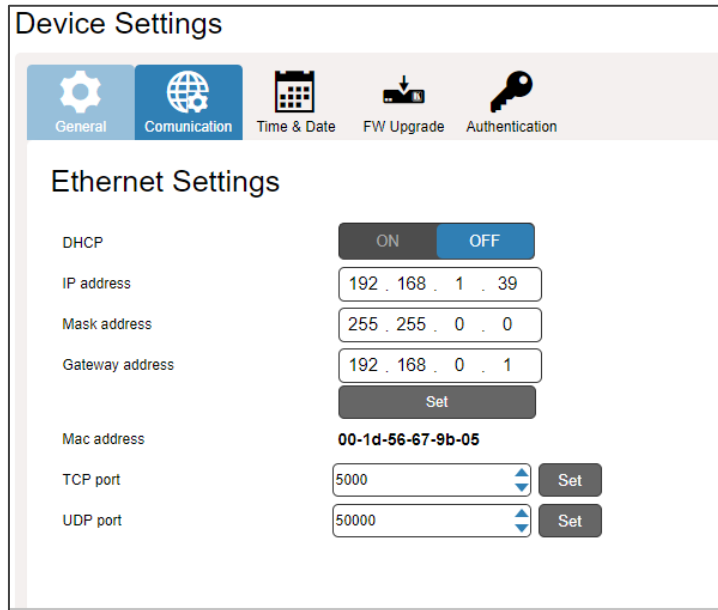

The screenshot shows the 'Device Settings' page with the 'Communication' tab selected. Under 'Ethernet Settings', the 'DHCP' toggle is set to 'OFF'. The 'IP address' field contains '192 . 168 . 1 . 39', the 'Mask address' field contains '255 . 255 . 0 . 0', and the 'Gateway address' field contains '192 . 168 . 0 . 1'. Below these fields is a 'Set' button. The 'Mac address' field displays '00-1d-56-67-9b-05'. The 'TCP port' field has a dropdown menu set to '5000' and a 'Set' button. The 'UDP port' field has a dropdown menu set to '50000' and a 'Set' button.

Figure 28: Device Settings Page – Communication Tab

3. If DHCP is OFF, change any of the parameters (IP Address, Netmask and/or Gateway).
4. Click **Set**.

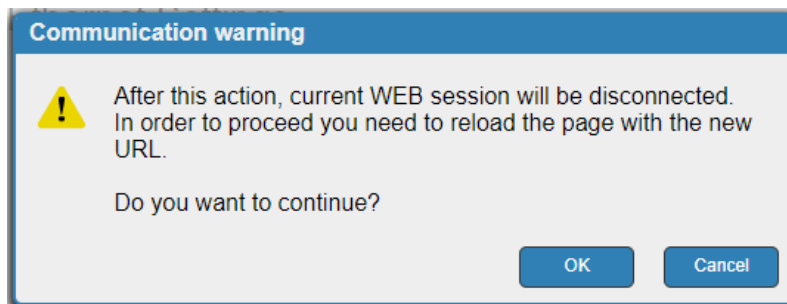

Figure 29: Device Settings Page – Communication Warning

5. Click **OK**.
The page with the new settings is reloaded.
6. If required, change the TCP/UDP port number.
7. Click **Set**.

The port number has changed.

Changing Ethernet Settings when DHCP is On

When DHCP is set to ON, the device IP address is selected automatically by the system.

To set parameters when DHCP is set to ON:

1. In the Navigation pane, click **Device Settings**. The Device Settings page appears.
2. Take note of the Device Name (required for step 6).
3. Click the **Communication** tab (see [Figure 28](#)).
4. Click **DHCP ON**. The following message appears:

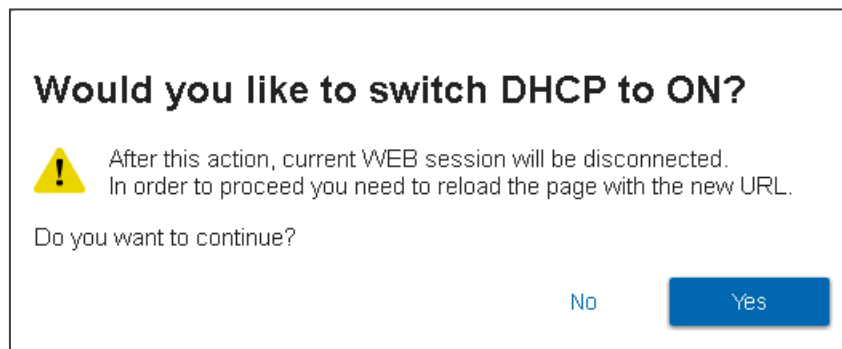

Figure 30: Network Settings Page

5. Click **Yes**.
6. Type the device name in the address bar of your browser to reload the page.
You can read the new IP address from the Network Settings page.

DHCP is ON.

Setting DHCP to Off

When setting DHCP to off, you need to enter the IP address manually.

To turn OFF DHCP settings:

1. In the Navigation pane, click **Device Settings**. The Device Settings page appears.
2. Click the **Communication** tab (see [Figure 28](#)).
3. Click DHCP **OFF**. The DHCP OFF message appears:



DHCP OFF

Set a new IP address.
Following this you will lose your connection to the device.
To reconnect, enter the new IP address in your Web browser.

Custom IP 192 . 168 . 1 . 40

Default IP 192.168.1.39

Cancel Apply

Figure 31: Device Settings Page – DHCP ON Message

4. Check **Custom IP** and enter an IP address or Check **Default IP**.
5. Click **Apply**.

The web page reloads with the new IP address.

Setting the Date and Time

Set the date and time in one of the following methods:

- [Setting the Date and Time Manually](#) on page 34.
- [Setting the Date and Time from a Server](#) on page 35.

Setting the Date and Time Manually

To manually set the date and time:

1. In the Navigation pane, click **Device Settings**. The Device Settings page appears.
2. Click the Time and Date tab.

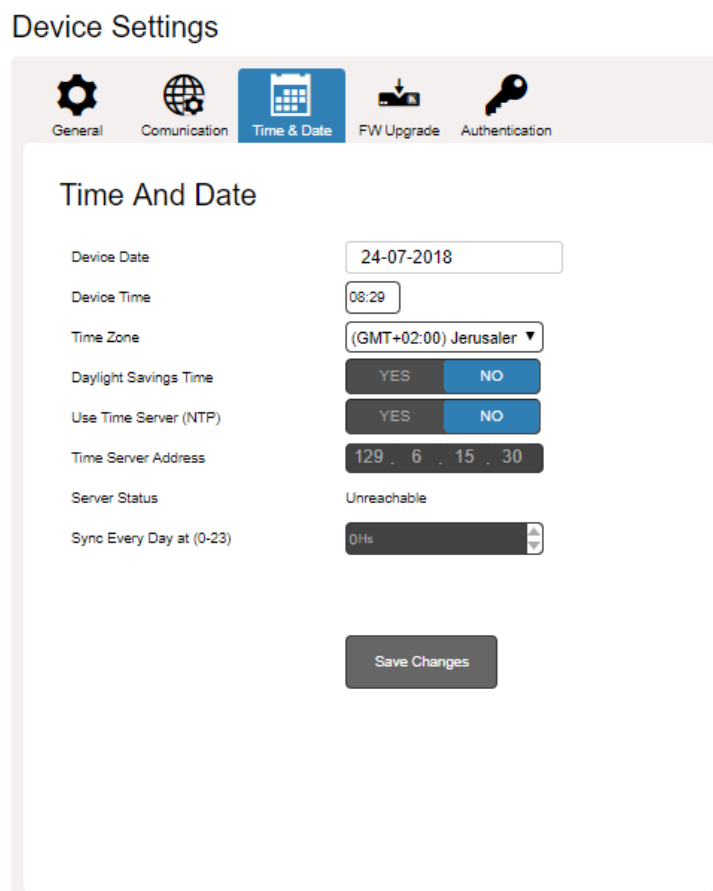

Figure 32: Device Settings Page – Date & Time Tab

3. Update the date and time as necessary:
 - Click the **Device Date** text box and change the date.
 - Click the **Device Time** text box and change the time.
 - Select the **Time Zone**.
 - Click **YES** to set to **Daylight Savings Time**.

The date and time are set.

Setting the Date and Time from a Server

You can set the date and time from a time server.

To use a time server to set the date and time:

1. In the Navigation pane, click **Device Settings**. The Device Settings page appears.
2. Click the Time and Date tab.
3. Click **YES** next to **Use Time Server (NTP)**.
4. Enter the **Time Server Address**.
5. Set the time for the device to sync to the server (**Sync every day at (0-23)**).

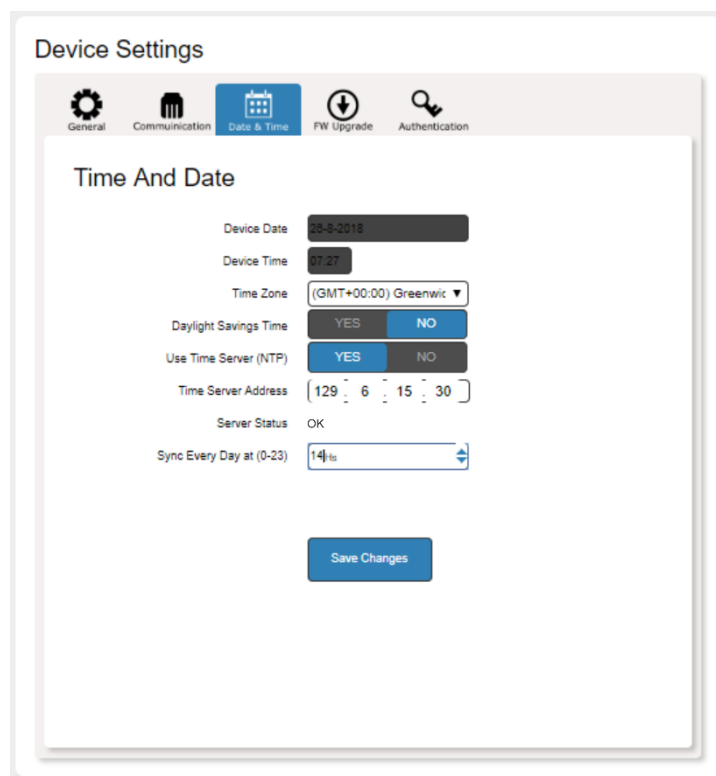

Figure 33: Device Settings Page – Using a Time Server

6. Click **Save Changes**.

The date and time are set.

Upgrading the Firmware

To perform firmware upgrade:

1. In the Navigation pane, click **Device Settings**. The Device Settings page appears.
2. Select the FW Upgrade tab.
3. Click **Update**.

4. Select the new firmware and click **Open**. The following Warning appears:

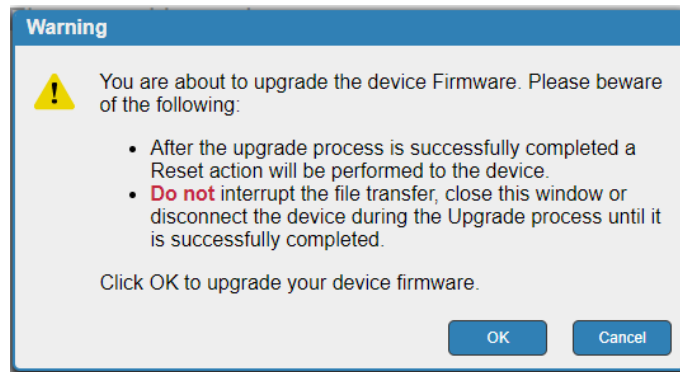

Figure 34: Device Settings Page – Firmware Upgrade Warning

5. Click **OK**. Wait for completion of the upgrade process:

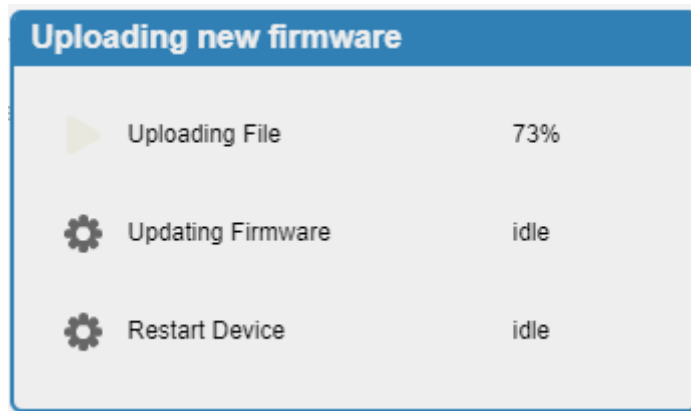

Figure 35: Device Settings Page – Firmware Upgrade Process

6. Wait for the device to restart.



Figure 36: Device Settings Page – Uploading New Firmware

The firmware is upgraded and the web pages reload.

Setting Authentication

The **VS-622DT** enables activating security and defining logon authentication details. When device security is enabled, Web page access requires authentication. To define access to the Web pages (locked or unlocked), in the Navigation pane click **Device Settings** and select the Authentication tab.



By default, the Web pages are not secured (user name and password are both: **Admin**).

The current authentication status is indicated by the locked (🔒) or unlocked (🔓) lock icon on the top right side of the web page.

To access Web pages using the password:

1. In the Navigation pane, click **Device Settings** and select the **Authentication** tab. The Authentication page appears:

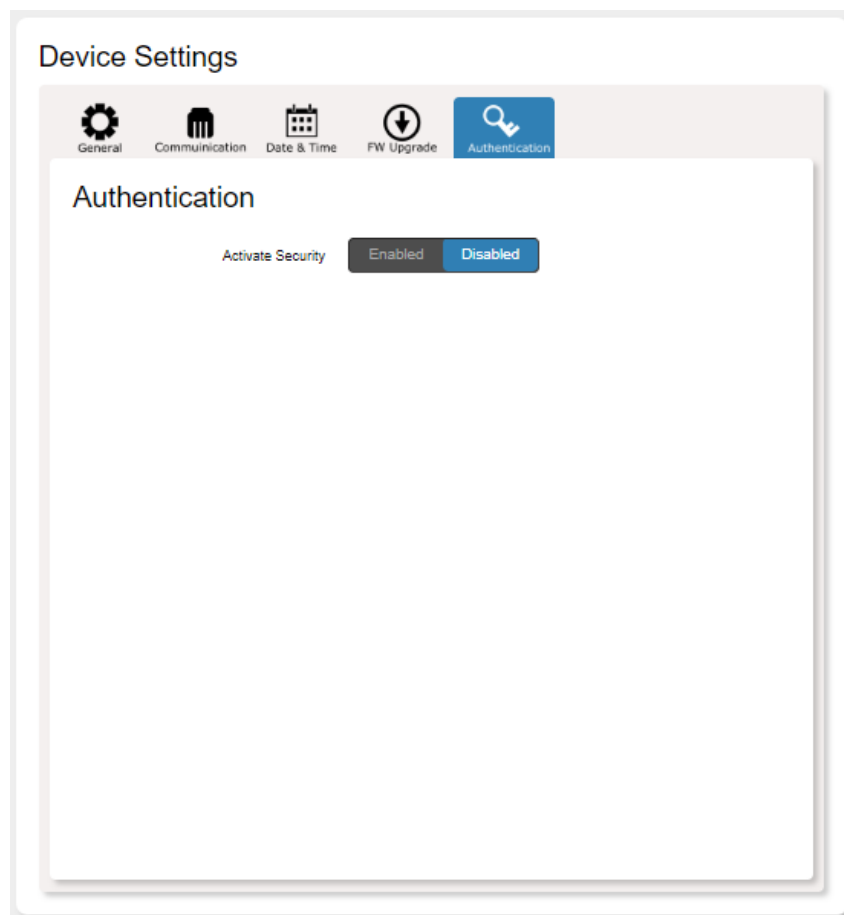
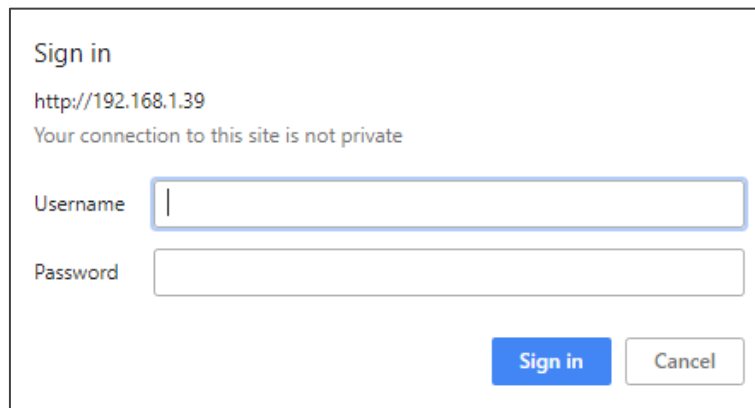

Figure 37: Authentication Page – Security Disabled

2. Click **Enabled**. A confirmation page appears.

3. Click **OK**. The Sign in page appears:



Sign in

http://192.168.1.39

Your connection to this site is not private

Username

Password

Sign in Cancel

Figure 38: Authentication Page – Security Activation Message

4. Enter the default username and password (Admin, Admin) and click **Sign in**. The Web page reloads.
5. In the Navigation pane, click **Device Settings** and select the **Authentication** tab. The Authentication page appears:

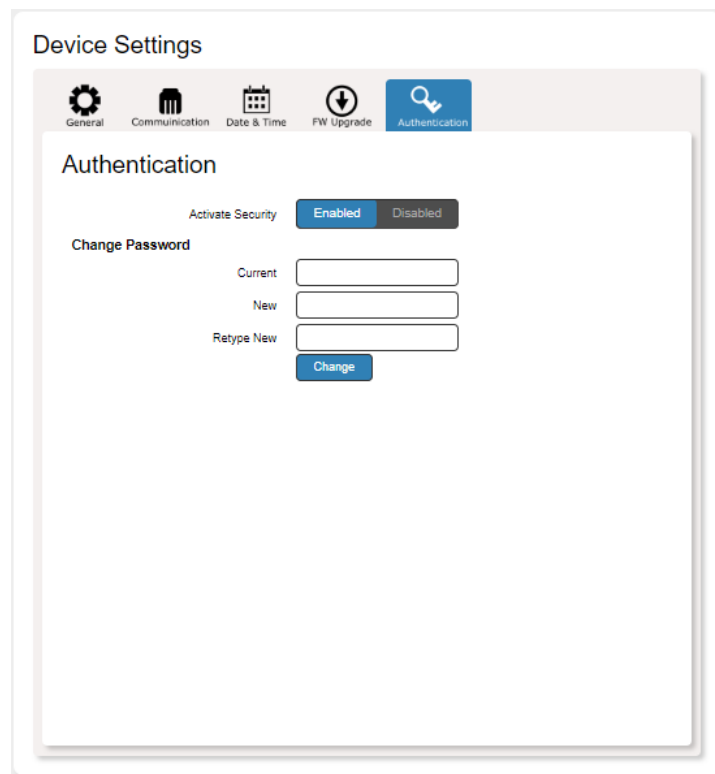

Device Settings

General Communication Date & Time FW Upgrade **Authentication**

Authentication

Activate Security **Enabled** Disabled

Change Password

Current

New

Retype New

Change

Figure 39: Authentication page – Security Enabled

6. Change the password as instructed and click **Change**. A confirmation message appears.
7. Click **OK**. A success message appears.
8. Click **OK**.

The web page reloads, security is enabled, and access is password restricted.

To access Web pages without using the password:

1. In the Navigation pane, click **Device Settings** and select the **Authentication** tab. The Authentication page appears (see [Figure 39](#)).
2. Click **Disabled**. The Confirmation message appears:

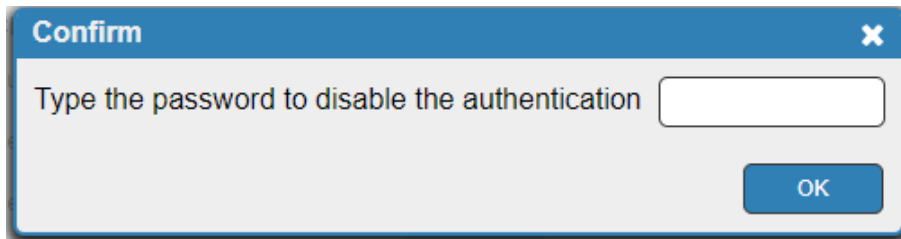

Figure 40: Authentication Page – Disabling Authentication

3. Type the current password and click **OK**.

Security is disabled.

Managing IO Gateway Settings

The IO Gateway page enables performing the following functions:

- [Configuring RS-232 Signal Tunneling](#) on page [40](#).
- [Setting GPI/O](#) Parameters on page [42](#).
- [Setting Relays](#) on page [47](#).

Configuring RS-232 Signal Tunneling

Use the Tunneling tab to route RS-232 via the RS-232 port (29) or the HDBT OUT 1 port (24).

To configure port tunneling:

1. In the Navigation pane, click **IO Gateway**. The IO Gateway page appears displaying the Tunneling tab.

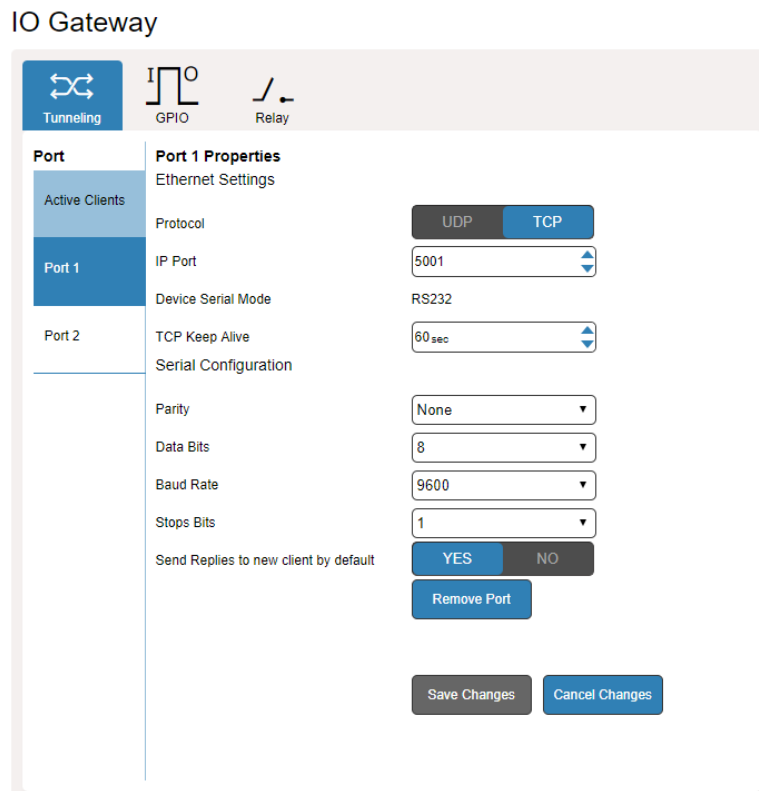

Figure 41: IO Gateway Page – Tunneling Settings

2. Select **Port 1** (the RS-232 port) or **Port 2** (the HDBT OUT 1 port).
3. Optionally, configure the following:
 - Set the protocol to UDP or TCP.
 - Enter the port number.
 - Set the TCP Keep Alive time (duration between two transmissions to prevent the link to be broken).

- Set the serial configuration of the port (Parity, Data Bits, Baud Rate, Stop Bits).
- Click **YES** to enable sending replies to new clients by default or **NO** to disable.
- Remove the Port to exit tunneling
- **Save Changes** or **Cancel Changes**.

Port tunneling is configured.

Viewing Active Clients

To view active clients:

1. In the Navigation pane, click **IO Gateway**. The IO Gateway page appears displaying the Tunneling tab.
2. Click **Active Clients** and view the following.
 - **IP** – Client IP address.
 - **To** – The port to which it is connected on the **VS-622DT**.
 - **Through** – Method of connection (UDP or TCP).
 - **S/R** (Send Replies) – enabled/disabled for the port (see [Figure 41](#)).

IO Gateway

IP	To	Through	S/R
172.31.111.1	Port 2	TCP Wired Ethernet	Yes
172.31.111.4	Port 1	TCP Wired Ethernet	Yes

Figure 42: IO Gateway Page – Active Clients Data

Setting GPI/O Parameters

Use the GPIO setting tab to configure the following GPI/O ports:

- [Configuring the Digital Input Trigger Type](#) on page [42](#).
- [Configuring the Digital Output Trigger Type](#) on page [44](#).
- [Configuring the Analog Input Trigger Type](#) on page [45](#).



GPI/O ports can be incorporated into automation only when they are set as inputs (see [Configuring Room Automation](#) on page [48](#)).

Configuring the Digital Input Trigger Type

Digital Input trigger mode reads the digital input of an external sensor device that is connected to the GPIO port and can detect a:

- High state voltage – when the connected sensor passes the maximum threshold from the low state.
- Low State voltage – when the connected sensor passes the minimum threshold from the high state.

The minimum and maximum threshold levels are defined in the GPIO web page.

To configure the digital input trigger type:

1. In the Navigation pane, click **IO Gateway**. The IO Gateway page appears (see [Figure 41](#)).
2. Click **GPIO**. The GPIO tab appears.

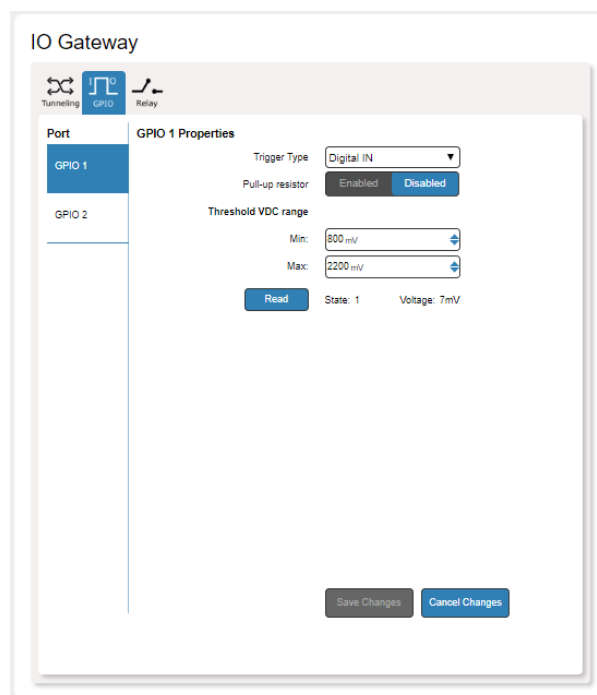

Figure 43: IO Gateway Page – GPIO Tab

3. Select **GPIO 1** or **GPIO 2**.
4. Set **Trigger Type** to **Digital IN**.

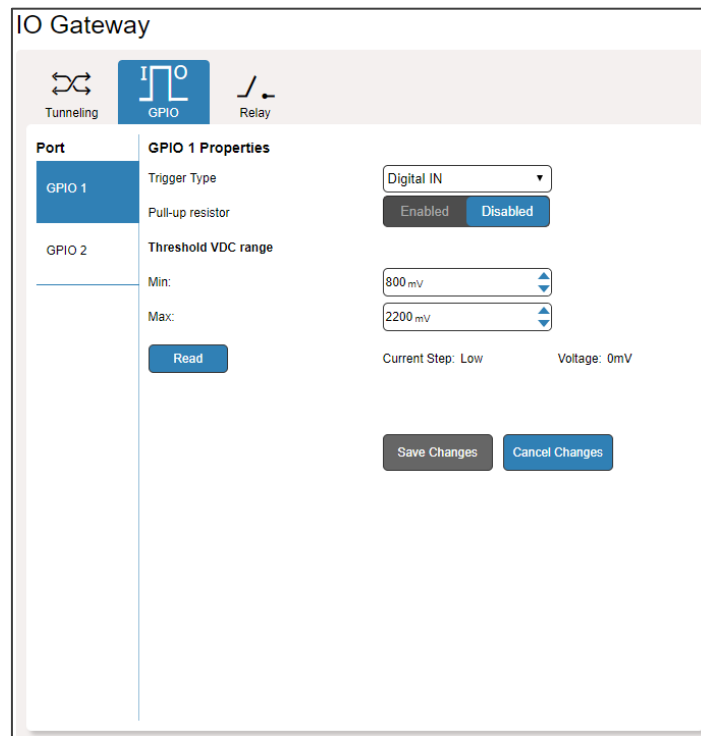

Figure 44: IO Gateway Page – Digital IN GPIO Type

5. Enable/Disable **Pull-up resistor**:

- When enabled, an open circuit is detected as high and a short circuit is detected as low.
For example, enable the pull-up resistor when connecting to a push button switch (one terminal of the switch to ground, and the other to the input) or when connecting to an alarm sensor where a closed circuit triggers a series of actions.
When the pull-up is enabled, the port state is high and to be triggered it must be pulled low by the externally connected sensor.
- When disabled, the port state is low and to be triggered it must be pulled high by the externally connected sensor.
Use this setup, for example, for a high temperature alarm that exceeds the maximum voltage threshold.



You need to set the threshold voltage at which the port changes state.

6. Set the minimum and maximum threshold voltages.
7. Once connected, click **Read** to view the current state (High or Low) and voltage of the port.
8. Click **Save Changes**.
The Digital IN GPIO port is configured.



The default parameter settings change depending on which trigger type is selected.

Configuring the Digital Output Trigger Type

The digital output mode function is defined by the pull-up resistor setup:

- When enabled, the external source device determines the voltage output; the maximum voltage is 30V DC and the maximum current is 100mA.

The port state is high. For the state to be low, set Current Status to **Low**.

Use this setup to control external devices such as room or light switches.



Make sure that the current in this configuration does not exceed 100mA!

- When disabled, the voltage output is TTL positive logic: open: ~ 3.5V; closed: ~ 0.3V. The port state is low and to set it to high, you must click **High** in Current Status.
- Use this setup to control devices that accept a TTL signal such as LED powering. Set the trigger type to Digital OUT. With this selection, the external device, (for example, an electric blind) is controlled by the **VS-622DT**.

To configure the digital output trigger type:

1. In the Navigation pane, click **IO Gateway**. The IO Gateway page appears (see [Figure 41](#)).
2. Click **GPIO**. The GPIO tab appears (see [Figure 43](#)).
3. Select **GPIO 1** or **GPIO 2**.
4. Set **Trigger Type** to **Digital OUT**. The following warning appears:

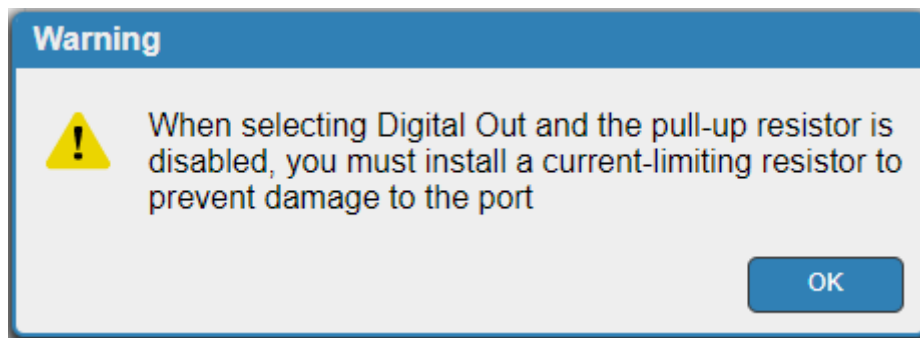

Figure 45: Digital Out Selection Warning Popup

5. Click **OK**.

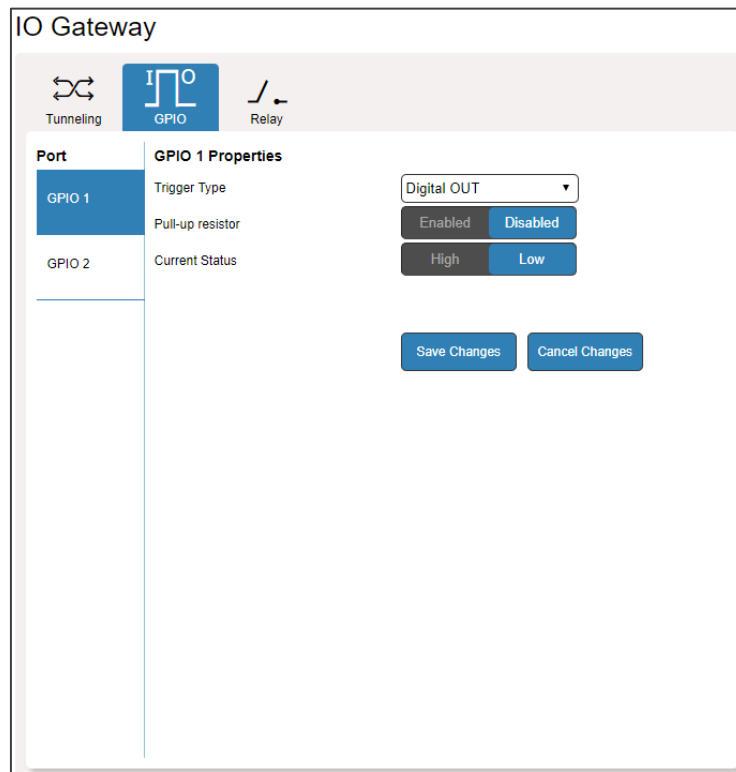

Figure 46: IO Gateway Page – GPIO Digital OUT

6. **Enable/Disable** Pull-up resistor.
7. Set Current Status to **High/Low**.
8. Click **Save Changes**.

The Digital OUT GPIO port is configured.

Configuring the Analog Input Trigger Type

In the Analog In trigger type, the port is triggered by an analog external device, such as, a volume control device that changes gradually. The trigger is activated once when the detected voltage is within 0 to 30V DC voltage range.

- You can select the number of steps the analog input signal will be divided into, starting with step 1 to a maximum of 100.
The voltage of each step is dependent on the number of steps selected:
The individual step voltage equals 30V divided by the number of steps.

To configure the analog input trigger type:

1. In the Navigation pane, click **IO Gateway**. The IO Gateway page appears (see [Figure 41](#)).
2. Click **GPIO**. The GPIO tab appears (see [Figure 43](#)).
3. Select **GPIO 1** or **GPIO 2**.

4. Set **Trigger Type** to **Analog IN**.

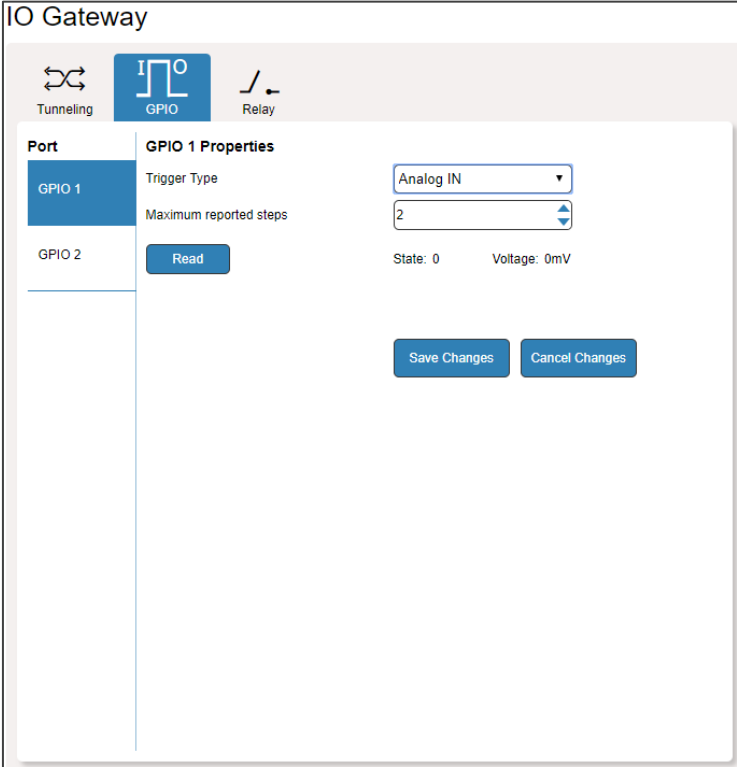

Figure 47: IO Gateway Page – GPIO Analog IN Settings

- 5. Set the number of steps.
- 6. Once connected, click **Read** to view the step number and the voltage.
- 7. Click **Save Changes**.

The Analog IN GPIO port is configured.

Setting Relays

Use the Relay tab to open or close a relay. By default, the relay is set to Open.

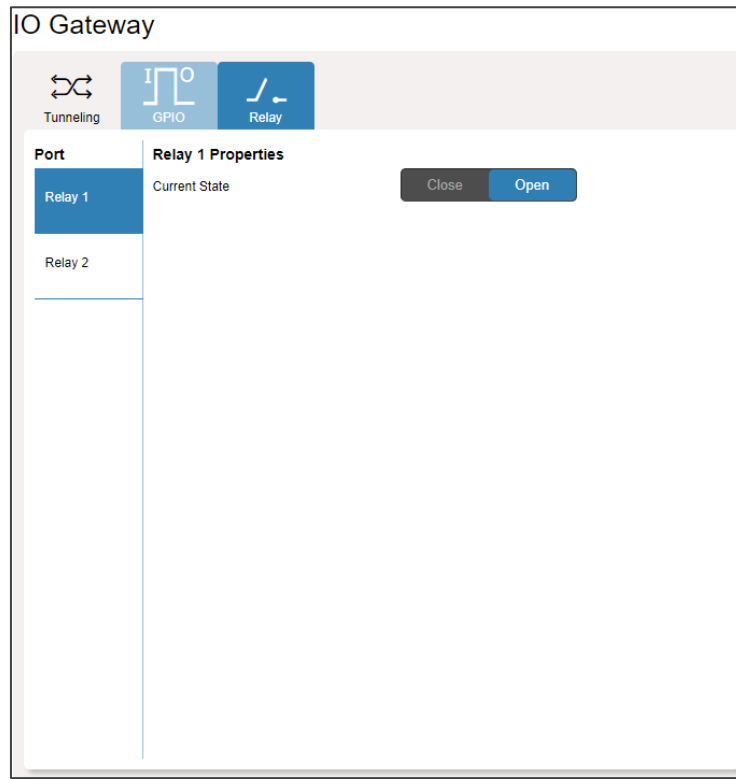

Figure 48: IO-Gateway Page – Relay Settings Tab

The relay ports have the following characteristics:

- Rated at 30V DC and 1A.
- Default state of normally open.
- A non-latching relay function, that is, the contact is left open when unpowered or on power up state. This means that if a relay is closed and power is lost, the relay returns to its default state. To return it to its pre-power loss state, the setting must be changed using either the Web pages or a P3000 command.

To close a relay:

1. In the Navigation pane, click **IO Gateway**. The IO Gateway page appears.
2. Click **Relay**. The Relay tab appears.
3. Click **Close**.

The relay closes.

Configuring Room Automation

Use the Automation page to access Kramer Maestro V1.5 room automation. Maestro is a powerful tool that enables you to configure single-trigger room element automation scenarios without the need for complicated programming. To use room automation, you need to define triggers that, upon an event, will execute scripts which include a sequence of actions (commands, which can appear in different scenarios) that will be carried out via any defined ports.

To access room automation:

1. In the Navigation pane, click **Automation**. The Maestro page appears.

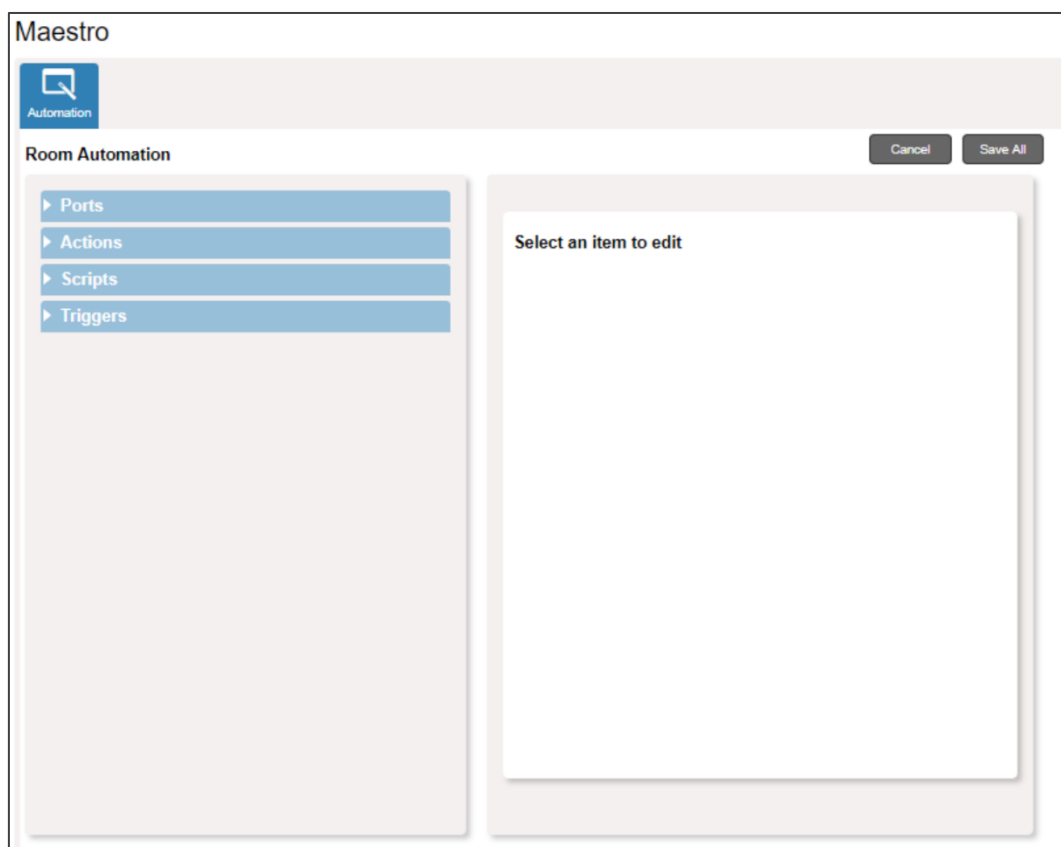

Figure 49: Automation – Maestro Page

For further details on how to use room automation, refer to the *Kramer Maestro User Manual*, available at www.kramerav.com/downloads/VS-622DT.

Viewing General Information

The VS-622DT About page lets you view the web page version and Kramer Electronics Ltd details.



Figure 50: About Page

Technical Specifications

Inputs	2 HDBT with PoE	On female RJ-45 connectors
	4 HDMI	On female HDMI connectors
Outputs	1 HDBT with PoE	On a female RJ-45 Connector
	1 HDMI	On a female HDMI connector
	2 Stereo Balanced Audio	On 5-pin terminal block connectors
	1 Power Amplifier for Stereo or 1 Mono Speaker	On a 4-pin large terminal block
Ports	1 Ethernet	On an RJ-45 female connector
	2 RS-232	On 3-pin terminal blocks
	1 USB (PROG)	On a mini USB connector, for firmware upgrade
	4 IR	On 2-pin terminal block connectors
	2 GPI/O	On 2-pin terminal block connectors
	2 Relays	On 2-pin terminal block connectors
Video	Max. Data Rate	10.2Gbps (3.4Gbps per graphics channel)
	Max. Resolution	Up to 4K@60Hz (4:2:0)
	Compliance	HDMI 2.0 and HDCP 1.4
Power Amplifier	Stereo	2x60W @4/8Ω
	Mono	1x120W @70V/100V
Extension Line	4K@60Hz (4:2:0)	Up to 100m (330ft)
	Full HD (1080p @60Hz 36bpp)	Up to 130m (430ft)
	HDBaseT Ultra Mode and Full HD (1080p @60Hz 24bpp)	Up to 180m (590ft)
User Interface	Controls	Input selection buttons, swap, EDID, lock and audio control buttons
	Indicators	Power, RS-232, IR, GPI/O and relay LEDs
	Remote	RS-232, Ethernet, Web pages, IR remote control transmitter, Programmable Maestro buttons interface
Supported Web Browsers	Windows 7	Internet Explorer, Firefox, Chrome, Safari
	Windows 10	Internet Explorer, Edge, Firefox, Chrome
	MAC 10.11	Safari
	iOS 10.3.2	Safari
	Android	N/A
Power	Consumption	250VA max.
	Source	100-240V AC

Environmental Conditions	Operating Temperature	0° to +40°C (32° to 104°F)
	Storage Temperature	-40° to +70°C (-40° to 158°F)
	Humidity	10% to 90%, RHL non-condensing
Regulatory Compliance	Safety	CE
	Environmental	RoHs, WEEE
Enclosure	Size	19", 1U
	Type	Aluminum
	Cooling	Fan ventilation
General	Net Dimensions (W, D, H)	43.6cm x 23.7cm x 4.4cm (17.2" x 9.3" x 1.7")
	Shipping Dimensions (W, D, H)	52.5cm x 33cm x 10.7cm (20.7" x 13" x 4.2")
	Net Weight	2.6kg (5.7lbs) approx.
	Shipping Weight	3.7kg (8.2lbs) approx.
Accessories	Included	Power Cord
Specifications are subject to change without notice at www.kramerav.com		

Default Parameters

RS-232			
Baud Rate:	115,200		
Data Bits:	8		
Stop Bits:	1		
Parity:	None		
Command Format:	ASCII Protocol 3000		
Example (Route input 1 to output 1):	#ROUTE 1,1,1<cr>		
Ethernet			
IP Address:	192.168.1.39	Default UDP Port #:	50000
Subnet mask:	255.255.0.0	Default TCP Port #:	5000
Default gateway:	192.168.0.1	Max. UDP ports:	70
		Max. TCP ports:	10
Full Factory Reset			
Front panel buttons:	Power off the device, press and hold the RESET button for 3 seconds while powering the device, and then release.		
Protocol 3000:	"#FACTORY" command followed by #RESET command.		
Web Pages:	In the Device Settings page, General tab, click Factory reset.		
Amplifier Values			
Amplifier output mode:	Lo-Z		
Speaker output from:	OUT 1		
Web pages Authentication			
User name:	Admin	Password:	Admin

Protocol 3000

The **VS-622DT 6x2 HDMI/HDBT Audio Matrix Switcher** can be operated using the Kramer Protocol 3000 serial commands. The command framing varies according to how you interface with the **VS-622DT**.

Generally, a basic video input switching command that routes a layer 1 video signal to HDMI out 1 from HDMI input 2 (ROUTE 1,1,2), is entered as follows:

- Terminal communication software, such as Hercules:

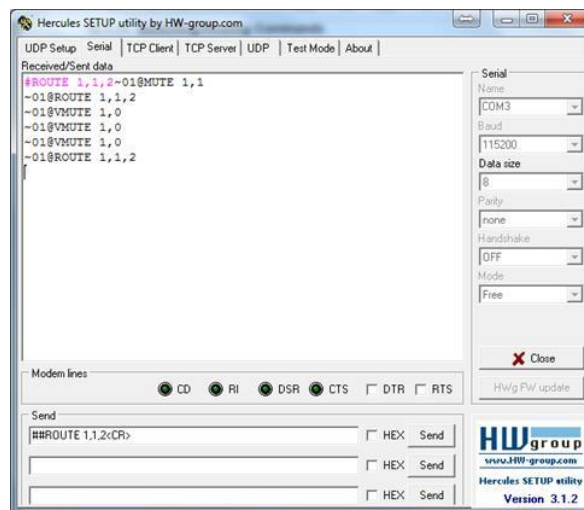

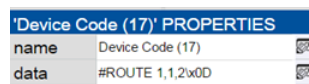

 The framing of the command varies according to the terminal communication software.

- K-Touch Builder (Kramer software):

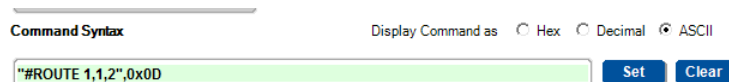

- K-Config (Kramer configuration software):



 All the examples provided in this section are based on using the K-Config software.

You can enter commands directly using terminal communication software (e.g., Hercules) by connecting a PC to the serial or Ethernet port on the **VS-622DT**. To enter `CR` press the Enter key (`LF` is also sent but is ignored by the command parser).

Commands sent from various non-Kramer controllers (e.g., Crestron) may require special coding for some characters (such as, `/X##`). For more information, refer to your controller's documentation.

For more information about Protocol 3000 commands, see:

- [Understanding Protocol 3000](#) on page [53](#).
- [Kramer Protocol 3000 Syntax](#) on page [54](#).
- [Protocol 3000 Commands](#) on page [55](#).

Understanding Protocol 3000

Protocol 3000 commands are structured according to the following:

- **Command** – A sequence of ASCII letters (A–Z, a–z and -). A command and its parameters must be separated by at least one space.
- **Parameters** – A sequence of alphanumeric ASCII characters (0–9, A–Z, a–z and some special characters for specific commands). Parameters are separated by commas.
- **Message string** – Every command entered as part of a message string begins with a message starting character and ends with a message closing character.



A string can contain more than one command. Commands are separated by a pipe (|) character.

- **Message starting character:**
 - # – For host command/query
 - ~ – For device response
- **Device address** – K-NET Device ID followed by @ (optional, K-NET only)
- **Query sign** – ? follows some commands to define a query request
- **Message closing character:**
 - CR – Carriage return for host messages (ASCII 13)
 - CR LF – Carriage return for device messages (ASCII 13) and line-feed (ASCII 10)
- **Command chain separator character** – Multiple commands can be chained in the same string. Each command is delimited by a pipe character (|). When chaining commands, enter the message starting character and the message closing character only at the beginning and end of the string.



Spaces between parameters or command terms are ignored. Commands in the string do not execute until the closing character is entered. A separate response is sent for every command in the chain.

Kramer Protocol 3000 Syntax

The Kramer Protocol 3000 syntax uses the following delimiters:

- **CR** = Carriage return (ASCII 13 = 0x0D)
- **LF** = Line feed (ASCII 10 = 0x0A)
- **SP** = Space (ASCII 32 = 0x20)

Some commands have short name syntax in addition to long name syntax to enable faster typing. The response is always in long syntax.

The Protocol 3000 syntax is in the following format:

- **Host Message Format:**

Start	Address (optional)	Body	Delimiter
#	<i>Device_id@</i>	Message	CR

- **Simple Command** – Command string with only one command without addressing:

Start	Body	Delimiter
#	Command SP <i>Parameter_1,Parameter_2,...</i>	CR

- **Command String** – Formal syntax with command concatenation and addressing:

Start	Address	Body	Delimiter
#	<i>Device_id@</i>	Command_1 <i>Parameter1_1,Parameter1_2,... </i> Command_2 <i>Parameter2_1,Parameter2_2,... </i> Command_3 <i>Parameter3_1,Parameter3_2,... ...</i>	CR

- **Device Message Format:**

Start	Address (optional)	Body	Delimiter
~	<i>Device_id@</i>	Message	CR LF

- **Device Long Response** – Echoing command:

Start	Address (optional)	Body	Delimiter
~	<i>Device_id@</i>	Command SP [<i>Param1 ,Param2 ...</i>] result	CR LF

Protocol 3000 Commands

This section includes the following commands:

- [System Commands](#) on page [55](#).
- [EDID Handling Commands](#) on page [68](#).
- [Switching/Routing Commands](#) on page [69](#).
- [Audio Commands](#) on page [73](#).
- [Communication Commands](#) on page [75](#).
- [I/O Gateway Commands](#) on page [81](#).
- [Step-in Commands](#) on page [87](#).

System Commands

Command	Description
#	Protocol handshaking
BUILD-DATE	Get device build date
FACTORY	Reset to factory default configuration
HELP	Get command list
MODEL	Get device model
PROT-VER	Get device protocol version
RESET	Reset device
SN	Get device serial number
VERSION	Get device firmware version
DISPLAY	Get output HPD status
HDCP-MOD	Set/get HDCP mode
HDCP-STAT	Get HDCP signal status
LOCK-FP	Get front panel lock state
NAME	Set/get machine (DNS) name
NAME-RST	Reset machine (DNS) name to factory default
SIGNAL?	Get input signal status
TIME	Set/get device time and date
TIME-LOC	Set/get local time offset from UTC/GMT
AV-SW-MODE	Get auto switch mode
BAUD	Set/get protocol serial baud rate
DPSW-STATUS	Get the DIP-switch status
FEATURE-LIST	Get feature state according to feature ID
PRI0	Get input priority

#

Functions		Permission	Transparency
Set:	#	End User	Public
Get:	-	-	-
Description		Syntax	
Set:	Protocol handshaking	# <code>CR</code>	
Get:	-	-	
Response			
~ <code>nn</code> @ <code>SP</code> <code>OK</code> <code>CR</code> <code>LF</code>			
Notes			
Validates the Protocol 3000 connection and gets the machine number. Step-in master products use this command to identify the availability of a device.			
K-Config Example			
"#", 0x0D			

BUILD-DATE

Functions		Permission	Transparency
Set:	-	-	-
Get:	BUILD-DATE?	End User	Public
Description		Syntax	
Set:	-	-	
Get:	Get device build date	# BUILD-DATE? <code>CR</code>	
Response			
~ <code>nn</code> @ BUILD-DATE <code>SP</code> <code>date</code> <code>SP</code> <code>time</code> <code>CR</code> <code>LF</code>			
Parameters			
<i>date</i> – Format: YYYY/MM/DD where YYYY = Year, MM = Month, DD = Day			
<i>time</i> – Format: hh:mm:ss where hh = hours, mm = minutes, ss = seconds			
K-Config Example			
"#BUILD-DATE?", 0x0D			

FACTORY

Functions		Permission	Transparency
Set:	FACTORY	End User	Public
Get:	-	-	-
Description		Syntax	
Set:	Reset device to factory default configuration	# FACTORY <code>CR</code>	
Get:	-	-	
Response			
~ <code>nn</code> @ FACTORY <code>SP</code> <code>OK</code> <code>CR</code> <code>LF</code>			
Notes			
This command deletes all user data from the device. The deletion can take some time. Your device may require powering off and powering on for the changes to take effect.			
K-Config Example			
"#FACTORY", 0x0D			

HELP

Functions		Permission	Transparency
Set:	-	-	-
Get:	HELP	End User	Public
Description		Syntax	
Set:	-	-	
Get:	Get command list or help for specific command	# HELP <code>CR</code>	
Response			
Multi-line: ~ <code>nn</code> @Device available protocol 3000 commands: <code>CR</code> <i>LF</i> <code>command</code> , <code>SP</code> <code>command</code> .. <code>CR LF</code>			
Parameters			
<i>COMMAND_NAME</i> – name of a specific command			
Notes			
To get help for a specific command use: HELP <code>SP</code> <i>COMMAND_NAME</i> <code>CR LF</code>			
K-Config Example			
`#HELP", 0x0D			

MODEL

Functions		Permission	Transparency
Set:	-	-	-
Get:	MODEL?	End User	Public
Description		Syntax	
Set:	-	-	
Get:	Get device model	# MODEL? <code>CR</code>	
Response			
~ <code>nn</code> @ MODEL <code>SP</code> <i>model_name</i> <code>CR LF</code>			
Parameters			
<i>model_name</i> – String of up to 19 printable ASCII chars			
Notes			
This command identifies equipment connected to Step-in master products and notifies of identity changes to the connected equipment. The Matrix saves this data in memory to answer REMOTE-INFO requests.			
K-Config Example			
`#MODEL?", 0x0D			

PROT-VER

Functions		Permission	Transparency
Set:	-	-	-
Get:	PROT-VER?	End User	Public
Description		Syntax	
Set:	-	-	
Get:	Get device protocol version	# PROT-VER? <input type="checkbox"/> CR	
Response			
~ <input type="checkbox"/> <input type="checkbox"/> @ PROT-VER <input type="checkbox"/> SP3000:version <input type="checkbox"/> CR LF			
Parameters			
version - XX.XX where X is a decimal digit			
K-Config Example			
`#PROT-VER?`, 0x0D			

RESET

Functions		Permission	Transparency
Set:	RESET	Administrator	Public
Get:	-	-	-
Description		Syntax	
Set:	Reset device	# RESET <input type="checkbox"/> CR	
Get:	-	-	
Response			
~ <input type="checkbox"/> <input type="checkbox"/> @ RESET <input type="checkbox"/> SPOK <input type="checkbox"/> CR LF			
Notes			
To reset the device, first send the #FACTORY command and then send #RESET. To avoid locking the port due to a USB bug in Windows, disconnect USB connections immediately after running this command. If the port was locked, disconnect and reconnect the cable to reopen the port.			
K-Config Example			
`#RESET`, 0x0D			

SN

Functions		Permission	Transparency
Set:	-	-	-
Get:	SN?	End User	Public
Description		Syntax	
Set:	-	-	
Get:	Get device serial number	# SN? <code>CR</code>	
Response			
~ <code>nn</code> @ SN <code>SP</code> <i>serial_number</i> <code>CR LF</code>			
Parameters			
<i>serial_number</i> – 11 decimal digits, factory assigned			
Notes			
This device has a 14-digit serial number, only the last 11 digits are displayed.			
K-Config Example			
"#SN?", 0x0D			

VERSION

Functions		Permission	Transparency
Set:	-	-	-
Get:	VERSION?	End User	Public
Description		Syntax	
Set:	-	-	
Get:	Get firmware version number	# VERSION? <code>CR</code>	
Response			
~ <code>nn</code> @ VERSION <code>SP</code> <i>firmware_version</i> <code>CR LF</code>			
Parameters			
<i>firmware_version</i> – XX.XX.XXXX where the digit groups are: major.minor.build version			
K-Config Example			
"#VERSION?", 0x0D			

DISPLAY

Functions		Permission	Transparency
Set:	-	-	-
Get	DISPLAY?	End User	Public
Description		Syntax	
Set:	-	-	
Get:	Get output HPD status	# DISPLAY? [SP] <i>out_id</i> [CR]	
Response			
~ <i>nn</i> @ DISPLAY [SP] <i>out_id,status</i> [CR LF]			
Parameters			
<i>out_id</i> – 1 (Output 1), 2 (Output 2)			
<i>status</i> – HPD status according to signal validation: 0 (Off), 1 (On), 2 (On and all parameters are stable and valid)			
Response Triggers			
A response is sent to the com port from which the Get was received, after command execution and:			
After every change in output HPD status from On to Off (0)			
After every change in output HPD status from Off to On (1)			
After every change in output HPD status form Off to On and all parameters (new EDID, etc.) are stable and valid (2)			
K-Config Example			
Get the output HPD status of Output 1:			
"#DISPLAY? 1",0x0D			

HDCP-MOD

Functions		Permission	Transparency
Set:	HDCP-MOD	Administrator	Public
Get	HDCP-MOD?	End User	Public
Description		Syntax	
Set:	Set HDCP mode	#HDCP-MOD[SP]inp_id,mode[CR]	
Get:	Get HDCP mode	#HDCP-MOD?[SP]inp_id[CR]	
Response			
Set/get: ~nn@HDCP-MOD[SP]inp_id,mode[CR LF]			
Parameters			
<i>inp_id</i> – input number: 1 (IN 1), 2 (IN 2), 3 (IN 3), 4 (IN 4), 5 (IN 5), 6 (IN 6)			
<i>mode</i> – HDCP mode: 0 (HDCP Off), 1 (HDCP On)			
Response Triggers			
Response is sent to the com port from which the Set (before execution) / Get command was received.			
Response is sent to all com ports after execution if HDCP-MOD was set by any other external control device (button press, device menu and similar) or HDCP mode changed.			
Notes			
Set HDCP working mode on the device input: HDCP supported – HDCP_ON (default) HDCP not supported – HDCP OFF HDCP supports changes following a detected sink - MIRROR OUTPUT			
K-Config Example			
Set the input HDCP-MODE of IN 1 to Off: "#HDCP-MOD 1,0",0x0D			

HDCP-STAT

Functions		Permission	Transparency
Set:	-	-	-
Get	HDCP-STAT?	End User	Public
Description		Syntax	
Set:	-	-	
Get:	Get HDCP signal status	# HDCP-STAT? [SP] <i>stage,stage_id</i> [CR]	
Response			
~ <i>nn</i> @ HDCP-STAT [SP] <i>stage,stage_id,status</i> [CR LF]			
Parameters			
<i>stage</i> – 0 (input), 1 (output)			
<i>stage_id</i> – for input stage: 1 (IN 1), 2 (IN 2), 3 (IN 3), 4 (IN 4), 5 (IN 5), 6 (IN 6); for output stage 1 (OUT 1), 2 (OUT 2)			
<i>status</i> – signal encryption On/Off status: 0 (HDCP Off), 1 (HDCP On)			
Response Triggers			
Response is sent to the com port from which the Set (before execution) / Get command was received			
Response is sent to all com ports after execution if HDCP-STAT was set by any other external control device (button press, device menu and similar) or HDCP mode changed.			
Notes			
On output – sink status.			
On input – signal status.			
K-Config Example			
Get the output HDCP-STATUS of IN 1: "#HDCP-STAT? 0,1",0x0D			

LOCK-FP

Functions		Permission	Transparency
Set:	LOCK-FP	End User	Public
Get	LOCK-FP?	End User	Public
Description		Syntax	
Set:	Lock front panel	# LOCK-FP [SP] <i>lock_mode</i> [CR]	
Get:	Get front panel lock state	# LOCK-FP?	
Response			
~ <i>nn</i> @ LOCK-FP [SP] <i>lock_mode</i> [SP]OK[CR LF]			
Parameters			
<i>lock_mode</i> – 0 (Off, unlock the front panel buttons), 1 (On, lock the front panel buttons)			
K-Config Example			
Unlock front panel: "#LOCK-FP 0",0x0D			

NAME

Functions		Permission	Transparency
Set:	NAME	Administrator	Public
Get:	NAME?	End User	Public
Description		Syntax	
Set:	Set machine (DNS) name	#NAME SP machine_name CR	
Get:	Get machine (DNS) name	#NAME? CR	
Response			
Set:	~nn@NAME SP machine_name CR LF		
Get:	~nn@NAME SP machine_name CR LF		
Parameters			
<i>machine_name</i> – String of up to 14 alpha-numeric characters (can include hyphens but not at the beginning or end)			
Notes			
The machine name is not the same as the model name. The machine name is used to identify a specific machine or a network in use (with DNS feature on).			
K-Config Example			
Set the DNS name of the device to “room-442”: "#NAME room-442",0x0D			

NAME-RST

Functions		Permission	Transparency
Set:	NAME-RST	Administrator	Public
Get:	-	-	-
Description		Syntax	
Set:	Reset machine (DNS) name to factory default	#NAME-RST CR	
Get:	-	-	
Response			
~nn@NAME-RST SP OK CR LF			
Notes			
Factory default of machine (DNS) name is “KRAMER_” + 4 last digits of device serial number			
K-Config Example			
Reset the machine name (S/N last digits are 0102): "#NAME-RST KRAMER_0102",0x0D			

SIGNAL

Functions		Permission	Transparency
Set:	-	-	-
Get	SIGNAL?	End User	Public
Description		Syntax	
Set:	-	-	
Get:	Get input signal lock status	# SIGNAL? [SP] <i>inp_id</i> [CR]	
Response			
~nn@ SIGNAL [SP] <i>inp_id,status</i> [CR LF]			
Parameters			
<i>inp_id</i> – input number: 1 (Input)			
<i>status</i> – signal status according to signal validation: 0 (Off), 1 (On)			
Response Triggers			
After execution, a response is sent to the com port from which the Get was received A response is sent after every change in input signal status from On to Off or from Off to On			
K-Config Example			
Get the input signal lock status of IN 1: `# SIGNAL? 1",0x0D			

TIME

Command Name		Permission	Transparency
Set:	TIME	Administrator	Public
Get:	TIME?	End User	Public
Description		Syntax	
Set:	Set device time and date	# TIME [SP] <i>day_of_week,date,time</i> [CR]	
Get:	Get device time and date	# TIME? [CR]	
Response			
~nn@ TIME [SP] <i>day_of_week, date,time</i> [CR LF]			
Parameters			
<i>day_of_week</i> – one of {SUN, MON, TUE, WED, THU, FRI, SAT}			
<i>date</i> – format: DD-MM-YYYY.			
<i>time</i> – format: hh:mm:ss			
Notes			
The year must be 4 digits. The device does not validate the day of week from the date. Time format – 24 hours Date format – Day, Month, Year			
K-Config Example			
Set device time and date to December 5, 2018 at 2:30pm: `# TIME MON 05-12-2018,14:30:00",0x0D			

TIME-LOC

Command Name		Permission	Transparency
Set:	TIME-LOC	End User	Public
Get:	TIME-LOC?	End User	Public
Description		Syntax	
Set:	Set local time offset from UTC/GMT	# TIME-LOC [SP] <i>UTC_off,DayLight</i> [CR]	
Get:	Get local time offset from UTC/GMT	# TIME-LOC? [CR]	
Response			
~nn@ TIME-LOC [SP] <i>UTC_off,DayLight</i> [CR LF]			
Parameters			
<i>UTC_off</i> – offset of device time from UTC/GMT (without daylight time correction)			
<i>DayLight</i> – 0 (no daylight-saving time), 1 (daylight saving time)			
Notes			
If the time server is configured, device time calculates by adding <i>UTC_off</i> to UTC time (that it got from the time server) + 1 hour if daylight savings time is in effect TIME command sets the device time without considering these settings			
K-Config Example			
Set local time offset to 3 with no daylight-saving time: "#TIME-LOC 3,0",0x0D			

AV-SW-MODE

Command Name		Permission	Transparency
Set:	-	-	-
Get:	AV-SW-MODE?	End user	Public
Description		Syntax	
Set:	-	-	
Get:	Get input auto switch mode (per output)	# AV-SW-MODE? [SP] <i>layer,output_id</i> [CR]	
Response			
~nn@ AV-SW-MODE [SP] <i>layer,output_id,mode</i> [CR LF]			
Parameters			
<i>layer</i> – 1 (video)			
<i>output_id</i> – for video layer: 0 (HDBT Out 1) 1 (HDMI Out 2)			
<i>mode</i> – 0 (Manual), 1 (Priority switch), 2 (Last connected switch)			
K-Config Example			
Get the input audio switch mode for HDMI Out: "#AV-SW-MODE? 1,1",0x0D			

BAUD

Functions		Permission	Transparency
Set:	BAUD	Administrator	Public
Get:	BAUD?	Administrator	Public
Description		Syntax	
Set:	Set protocol serial port baud rate	#BAUD SP baud_rate CR	
Get:	Get protocol serial port baud rate (for current baud rate)	#BAUD? CR	
Response			
~nn@BAUD SP baud_rate CR LF			
~nn@BAUD SP current_baud_rate CR LF			
Parameters			
baud_rate – 9600, 115200, else (new baud rate to set)			
current_baud_rate – 9600, 115200, else (current protocol serial port baud rate)			
Notes			
The new defined baud rate is stored in the EEPROM and used when powering up Default baud rate is 115200 (on factory reset). Only works with devices supporting this command (if ERR 002 is returned, the default baud rate is used).			
K-Config Example			
Set the baud rate to 9600: "#BAUD 9600", 0x0D			

DPSW-STATUS

Command Name		Permission	Transparency
Set:	-	-	-
Get:	DPSW-STATUS?	End User	Public
Description		Syntax	
Set:	-	-	
Get :	Get the DIP-switch state	#DPSW-STATUS? SP dp_sw_id CR	
Response			
~nn@DPSW-STATUS? SP dp_sw_id, status CR LF			
Parameters			
dp_sw_id – 1 to 8 (num of DIP switches)			
status – 0 (up), 1 (down)			
K-Config Example			
get the DIP-switch 2 status: "#DPSW-STATUS? 2", 0x0D			

FEATURE-LIST

Functions		Permission	Transparency
Set:	-	-	-
Get:	FEATURE-LIST?	End User	Public
Description		Syntax	
Set:	-	-	
Get:	Get feature state according to the feature ID	# FEATURE-LIST? [SP] <i>id</i> [CR]	
Response			
~ [nn] @ FEATURE-LIST [SP] <i>id,enable</i> [CR LF]			
Parameters			
<i>id</i> - 1 (Maestro), 2 (Room controller)			
<i>enable</i> - 0 (Disable), 1 (Enable)			
Notes			
This command is designed to be used by machines and not by users.			
K-Config Example			
Get the room controller feature state (for the room controller): "#FEATURE-LIST? 2",0x0D			

PRIO

Command Name		Permission	Transparency
Set:	-	-	-
Get	PRIO?	End User	Public
Description		Syntax	
Set:	-	-	
Get:	Get input priority	# PRIO? [SP] <i>input_id</i> [CR]	
Response			
~ [nn] @ PRIO [SP] <i>input_id,prio</i> [CR LF]			
Parameters			
<i>input_id</i> - 1 (HDBT IN 1) to 6 (INPUT 6)			
<i>prio</i> - assigned priority: 1 (Highest priority) to 6 (Lowest priority)			
Response Triggers			
After execution, response is sent to the com port from which the Set/Get was received After execution, response is sent to all com ports if PRIO was set by any other external control device (button press, device menu and similar)			
Notes			
The PRIO max value may vary for different devices			
K-Config Example			
Get INPUT 3 assigned priority: "#FEATURE-LIST? 3",0x0D			

EDID Handling Commands

Additional EDID data functions can be performed via the **VS-622DT** web pages or a compatible EDID management application, such as Kramer EDID Designer (see www.kramerav.com/product/EDID%20Designer).

Command	Description
CPEDID	Copy EDID data from the output to the input EEPROM

CPEDID

Functions	Permission	Transparency
Set: CPEDID	End User	Public
Get: -	-	-
Description	Syntax	
Set: Copy EDID data from the output to the input EEPROM	#CPEDID [SP]src_type,src_id,dst_type,dest_bitmap[CR]	
Get: -	-	
Response		
	~nn@CPEDID[SP]src_type,src_id,dst_type,dest_bitmap[CR LF]	
Parameters		
<p><i>src_type</i> – EDID source type (usually output): 0 (Input) , 1 (Output), 2 (Default EDID)</p> <p><i>src_id</i> – for input source: 1 (Input), for output source: 0 (Default EDID source), 1 (Output 1), 2 (Output 2)</p> <p><i>dst_type</i> – EDID destination type (usually input): 0 (input)</p> <p><i>dest_bitmap</i> – bitmap representing destination IDs. Format: xxxx...x, where x is hex digit. The binary form of every hex digit represents corresponding destinations. Setting '1' indicates that EDID data is copied to this destination. Setting '0' indicates that EDID data is not copied to this destination.</p>		
Response Triggers		
Response is sent to the com port from which the Set was received (before execution)		
Notes		
<p>Destination bitmap size depends on device properties (for 64 inputs it is a 64-bit word)</p> <p>Example: bitmap 0x0013 means inputs 1, 2 and 5 are loaded with the new EDID.</p> <p>In this device, if the destination type is input (0), the bitmap size is 8 bit, for example bitmap 0x81 means the inputs 1 and 8 are loaded with the new EDID.</p>		
K-Config Example		
Copy the EDID data from the Output 1 (EDID source) to the Input:		
`#CPEDID 1,1,0,0x1",0x0D`		
Copy the EDID data from the default EDID source to the Input:		
`#CPEDID 2,0,0,0x1",0x0D`		

Switching/Routing Commands

Command	Description
MTX-MODE	Get auto-switch mode
ROUTE	Set/get layer routing
REMOTE-INFO	Get connected Step-in module information
VID	Set/get video switch state

MTX-MODE

Command Name		Permission	Transparency
Set:	-	-	-
Get:	MTX-MODE?	End User	Public
Description		Syntax	
Set:	-	-	
Get :	Get auto-switch mode	# MTX-MODE? <input type="checkbox"/> <i>output_id</i> <input type="checkbox"/>	
Response			
~ <input type="checkbox"/> @ MTX-MODE <input type="checkbox"/> <i>output_id,mode</i> <input type="checkbox"/>			
Parameters			
<i>output_id</i> - 1 (HDBT OUT 1), 2 (HDMI OUT 2)			
<i>mode</i> - 0 (Manual), 1 (Auto priority), 2 (Auto last connected)			
Response Triggers			
After execution, a response is sent to the comm port from which the Set/Get was received			
After execution, a response is sent to all comm ports if MTX-MODE was set by any other external control device (button press, WEB, device menu and similar)			
Notes			
Not recommended for new devices			
K-Config Example			
Get the auto switch mode of HDMI Out: `#MTX-MODE? 1", 0x0D`			

ROUTE

Command Name		Permission	Transparency
Set:	ROUTE	End User	Public
Get:	ROUTE?	End User	Public
Description		Syntax	
Set:	Set layer routing	#ROUTE[SP]layer,dest,src[CR]	
Get:	Get layer routing	#ROUTE?[SP]layer,dest[CR]	
Response			
~nn@ROUTE[SP]layer,dest,src[CR LF]			
Parameters			
<i>layer</i> – 1 (Video) <i>dest</i> – 1 (HDBT OUT 1), 2 (HDMI OUT 2), * (All), x (Disconnect) <i>src</i> – Source ID: 1 (Input 1) to 6 (Input 6)			
Notes			
This command replaces all other routing commands			
K-Config Example			
Set the remote input switching of video to HDBT OUT 1 from HDMI In 2: "#ROUTE 1,1,2",0x0D			

REMOTE-INFO

Command Name	Permission	Transparency
Set:		
Get:	REMOTE-INFO?	End User Public
Description	Syntax	
Set:		
Get:	Get connected Step-in module info	# REMOTE-INFO? [SP] <i>stage,stage_id</i> [CR]
Response		
Get:	~nn@ REMOTE-INFO [SP] <i>stage,stage_id,connected,model_name,curr_input,capabilities,num_of_inputs,num_of_ctl_btn,type1,type2...typeN</i> [CR LF]	
Parameters		
<i>stage</i> – 0 (input), <i>stage_id</i> – for inputs: 1 (Input 1), 2 (Input 2), 3 (Input 3), 4 (Input 4), 5 (Input 5), 6 (Input 6) <i>connected</i> – 0 (Disconnected), 1 (Connected) <i>model_name</i> – model name string <i>curr_input</i> – 1 to 6 (Input, currently chosen on step-in module) <i>capabilities</i> – 1 (Supports Step-in), 0 (Does not support Step-in) <i>num_of_inputs</i> – number of inputs on step-in module <i>num_of_ctl_btn</i> – number of control buttons on step-in module <i>type1, type2... typeN</i> – input type (on step-in module): 0 (Undefined), 1 (DVI), 2 (HDMI), 3 (DisplayPort), 4 (HDBaseT), 5 (SDI), 6 (VGA), 7 (DGKat)		
Notes		
<p>The GET command identifies input switching on Step-in clients</p> <p>The SET command is for remote input switching on Step-in clients (essentially via by the Web)</p> <p>This is a legacy command. New Step-in modules support the ROUTE command</p>		
K-Config Example		
<p>Get the remote info of the step-in device (DIP-30) that is connected to input 3:</p> <pre>"#REMOTE-INFO 0,3",0x0D</pre>		

VID

Command Name		Permission	Transparency
Set:	VID	End User	Public
Get:	VID?	End User	Public
Description		Syntax	
Set:	Set video switch state	#VID[SP]in>out[CR]	
Get:	Get video switch state	#VID?[SP]out[CR]	
Response			
Set:	~nn@VID[SP]in>out[CR LF]		
Get:	~nn@VID[SP]out[CR LF]		
Parameters			
<i>in</i> - 1 (Input 1) 1 (Input 1), 2 (Input 2), 3 (Input 3), 4 (Input 4), 5 (Input 5), 6 (Input 6) or 0 (Disconnect output) > - connection character between in and out parameters <i>out</i> - 1 (HDBT OUT 1), 2 (HDMI OUT 2), * (for all outputs)			
Notes			
The GET command identifies input switching on Step-in clients The SET command is for remote input switching on Step-in clients (essentially via by the Web) This is a legacy command. New Step-in modules support the ROUTE command			
K-Config Example			
Set the video switch state of INPUT 1 to HDBT OUT 1: "#VID 1>1",0x0D			

Audio Commands

Command	Description
AUD-LVL	Set/get volume level
AUD-SWAP	Set/get audio output swap
MUTE	Set/get audio mute
AUD-HI-Z	Get Hi-Z status

AUD-LVL

Functions		Permission	Transparency
Set:	AUD-LVL	End User	Public
Get:	AUD-LVL?	End User	Public
Description		Syntax	
Set:	Set volume level	#AUD-LVL[SP]stage,channel,volume[CR]	
Get:	Get volume level	#AUD-LVL?[SP]stage,channel[CR]	
Response			
~nn@AUD-LVL[SP]stage,channel,volume[CR LF]			
Parameters			
stage – 1 (For output processing)			
channel – 1 (AUDIO OUT 1), 2 (AUDIO OUT 2), 3 (Power amp)			
volume – volume level -80db to 10dB			
K-Config Example			
Set AUDIO OUT 1 level to -50dB: "#AUD-LVL 1,2,-50",0x0D			

AUD-SWAP

Command Name		Permission	Transparency
Set:	AUD-SWAP	End User	Public
Get:	AUD-SWAP?	End User	Public
Description		Syntax	
Set:	Set audio output swap	#AUD-SWAP[SP]swap_mode[CR]	
Get:	Get audio output swap status	#AUD-SWAP?[CR]	
Response			
~nn@AUD-SWAP[SP]swap_mode[CR LF]			
Parameters			
swap_mode – 0 (OFF), 1 (ON)			
K-Config Example			
Swap outputs: "#AUD-SWAP 1",0x0D			

MUTE

Command Name		Permission	Transparency
Set:	MUTE	End User	Public
Get:	MUTE?	End User	Public
Description		Syntax	
Set:	Set mute ON/OFF for audio output.	#MUTE[SP]channel,mute_mode[CR]	
Get:	Get mute ON/OFF state for audio output.	#MUTE?[SP]channel[CRF]	
Response			
Get: ~[nn]@MUTE[SP]channel,mute_mode[CR LF]			
Parameters			
channel – 1 (HDBT OUT 1), 2 (HDMI OUT 2)			
mute_mode – mute the output: 0 (Off, unmute), 1 (On, mute)			
Response Triggers			
Response is sent to the com port from which the Set (before execution) / Get command was received			
After execution, response is sent to all com ports if CMD-NAME was set any other external control device (button press, device menu and similar) or genlock status was changed.			
Notes			
Mutes the audio output.			
K-Config Example			
Mute the HDBT OUT 1 audio output: "#MUTE 1,1",0x0D			

AUD-HI-Z

Functions		Permission	Transparency
Set:	AUD-HI-Z	End User	Public
Get:	AUD-HI-Z?	End User	Public
Description		Syntax	
Set:	Set High Z state	#AUD-HI-Z [CR]Channel[SP]HiZState,HiZVolt[CR]	
Get:	Get High Z status	#AUD-HI-Z? 3[CR]	
Response			
~[nn]@AUD-HI-Z[SP]Channel,HiZState,HiZVolt[CR LF]			
Parameters			
Channel – 3 (Power amp)			
HiZState – 1 (Hi-Z state high), 0 (Hi-Z state low)			
HiZVolt – Hi-Z volt level: 0 (70 Volt), 1 (100 Volt), 0xff (Ignore). Optional, active only in high state			
Notes			
Active only when state is high. Ignore everything else.			
K-Config Example			
Set the line level output to Hi-Z and 70V: "#AUD-HI-Z 2,1,0",0x0D			

Communication Commands

Command	Description
BEACON-INFO	Get beacon information
ETH-PORT	Set/get Ethernet port protocol
NET-CONFIG	Set/get a network configuration.
NET-DHCP	Set/get DHCP mode
NET-GATE	Set/get gateway IP
NET-IP	Set/get IP address
NET-MAC	Get MAC address
NET-MASK	Set/get subnet mask
TIME-SRV	Set/get time server settings
UART	Set/get com port configuration

BEACON-INFO

Functions	Permission	Transparency
Set: –	–	–
Get: BEACON-INFO?	End User	Public
Description	Syntax	
Set: –	–	
Get: Get beacon information, including IP address, UDP control port, TCP control port, MAC address, model, name	# BEACON-INFO? [SP] <i>port_id</i> [CR]	
Response		
~[nn]@BEACON-INFO[SP] <i>port_id,ip_string,udp_port,tcp_port,mac_address,model,name</i> [CR LF]		
Parameters		
<i>port_id</i> – ID of the Ethernet port, 0 (wired Ethernet connection). 1 and higher (for future use).		
<i>ip_string</i> – dot-separated representation of the IP address		
<i>udp_port</i> – UDP control port		
<i>tcp_port</i> – TCP control port		
<i>mac_address</i> – dash-separated MAC address		
<i>model</i> – device model		
<i>name</i> – device name		
Response Triggers		
After execution, notification is sent containing beacon information.		
Notes		
There is no Set command.		
The <i>port_id</i> parameter is not necessary and can be omitted.		
Example		
Get beacon information: #BEACON-INFO?<CR>		

ETH-PORT

Functions		Permission	Transparency
Set:	ETH-PORT	Administrator	Public
Get:	ETH-PORT?	End User	Public
Description		Syntax	
Set:	Set Ethernet port protocol	# ETH-PORT [SP] <i>portType</i> , <i>ETHPort</i> [CR]	
Get:	Get Ethernet port protocol	# ETH-PORT? [SP] <i>portType</i> [CR]	
Response			
~nn@ ETH-PORT [SP] <i>portType</i> , <i>ETHPort</i> [CR LF]			
Parameters			
<i>portType</i> – string of 3 letters indicating the port type: TCP, UDP			
<i>ETHPort</i> – TCP / UDP port number: 0-65565			
Notes			
If the port number you enter is already in use, an error is returned.			
The port number must be within the following range: 0-(2 ¹⁶ -1).			
K-Config Example			
Set the Ethernet port protocol for TCP to port 12457: "#ETH-PORT TCP,12457",0x0D			

NET-CONFIG

Functions		Permission	Transparency
Set:	NET-CONFIG	End User	Public
Get:	NET-CONFIG?	End User	Public
Description		Syntax	
Set:	Set a network configuration.	# NET-CONFIG [SP] <i>id</i> , <i>ip</i> , <i>net_mask</i> , <i>gateway</i> [CR LF]	
Get:	Get a network configuration.	# NET-CONFIG? [SP] <i>id</i> [CR LF]	
Response			
Get: ~nn@ NET-CONFIG [SP] <i>id</i> , <i>ip</i> , <i>net_mask</i> , <i>gateway</i> [CR LF]			
Parameters			
<i>id</i> – Ethernet connection ID number: 0			
<i>ip</i> – network IP address, in the following format: xxx.xxx.xxx.xxx			
<i>net_mask</i> – network mask, in the following format: xxx.xxx.xxx.xxx			
<i>gateway</i> – network gateway, in the following format: xxx.xxx.xxx.xxx			
Example			
Set the device network parameters to IP address 192.168.113.10, net mask 255.255.0.0, and gateway 192.168.0.1: #NET-CONFIG 0,192.168.113.10,255.255.0.0,192.168.0.1<CR>			

NET-DHCP

Functions		Permission	Transparency
Set:	NET-DHCP	Administrator	Public
Get:	NET-DHCP?	End User	Public
Description		Syntax	
Set:	Set DHCP mode	# NET-DHCP [SP] <i>mode</i> [CR]	
Get:	Get DHCP mode	# NET-DHCP? [CR]	
Response			
~nn@ NET-DHCP [SP] <i>mode</i> [CR LF]			
Parameters			
<i>mode</i> – 0 (do not use DHCP. Use the IP address set by the factory or the NET-IP command), 1 (try to use DHCP. If unavailable, use the IP address set by the factory or the NET-IP command)			
Notes			
Connecting Ethernet to devices with DHCP may take more time in some networks. To connect with a randomly assigned IP by DHCP, specify the device DNS name (if available) using the NAME command. You can also get an assigned IP by direct connection to RS-232 protocol port, if available. Consult your network administrator for correct settings.			
K-Config Example			
Enable DHCP mode, if available: `#NET-DHCP 1",0x0D			

NET-GATE

Functions		Permission	Transparency
Set:	NET-GATE	Administrator	Public
Get:	NET-GATE?	End User	Public
Description		Syntax	
Set:	Set gateway IP	# NET-GATE [SP] <i>ip_address</i> [CR]	
Get:	Get gateway IP	# NET-GATE? [CR]	
Response			
~nn@ NET-GATE [SP] <i>ip_address</i> [CR LF]			
Parameters			
<i>ip_address</i> – gateway IP address, in the following format: xxx.xxx.xxx.xxx			
Notes			
A network gateway connects the device via another network, possibly over the Internet. Be careful of security problems. Consult your network administrator for correct settings.			
K-Config Example			
Set the gateway IP address to 192.168.0.1: `#NET-GATE 192.168.000.001",0x0D			

NET-IP

Functions		Permission	Transparency
Set:	NET-IP	Administrator	Public
Get:	NET-IP?	End User	Public
Description		Syntax	
Set:	Set IP address	# NET-IP <input type="text" value="ip_address"/> <input type="text" value="CR"/>	
Get:	Get IP address	# NET-IP? <input type="text" value="CR"/>	
Response			
~ <input type="text" value="nn"/> @ NET-IP <input type="text" value="ip_address"/> <input type="text" value="CR LF"/>			
Parameters			
<i>ip_address</i> – IP address, in the following format: xxx.xxx.xxx.xxx			
Notes			
Consult your network administrator for correct settings.			
K-Config Example			
Set the IP address to 192.168.1.39: "#NET-IP 192.168.001.039",0x0D			

NET-MAC

Functions		Permission	Transparency
Set:	-	-	-
Get:	NET-MAC?	End User	Public
Description		Syntax	
Set:	-	-	
Get:	Get MAC address	# NET-MAC? <input type="text" value="CR"/>	
Response			
~ <input type="text" value="nn"/> @ NET-MAC <input type="text" value="mac_address"/> <input type="text" value="CR LF"/>			
Parameters			
<i>mac_address</i> – unique MAC address. Format: XX-XX-XX-XX-XX-XX where X is hex digit			
K-Config Example			
"#NET-MAC?",0x0D			

NET-MASK

Functions		Permission	Transparency
Set:	NET-MASK	Administrator	Public
Get:	NET-MASK?	End User	Public
Description		Syntax	
Set:	Set subnet mask	# NET-MASK <i>net_mask</i> CR	
Get:	Get subnet mask	# NET-MASK? CR	
Response			
~nn@ NET-MASK <i>net_mask</i> CR LF			
Parameters			
<i>net_mask</i> – format: xxx.xxx.xxx.xxx			
Response Triggers			
The subnet mask limits the Ethernet connection within the local network. Consult your network administrator for correct settings.			
K-Config Example			
Set the subnet mask to 255.255.0.0: "#NET-MASK 255.255.000.000",0x0D			

TIME-SRV

Functions		Permission	Transparency
Set:	TIME-SRV	Administrator	Public
Get:	TIME-SRV?	End User	Public
Description		Syntax	
Set:	Set time server	# TIME-SRV <i>mode,time_server,time_server_sync_hour</i> CR	
Get:	Get time server	# TIME-SRV? CR	
Response			
~nn@ TIME-SRV <i>mode,time_server,time_server_sync_hour,server_status</i> CR LF			
Parameters			
<i>mode</i> – 0 (OFF), 1 (ON) <i>time_server</i> – time server IP address or hostname. IP must be, in the following format: xxx.xxx.xxx.xxx <i>time_server_sync_hour</i> – not in use: 0 <i>server_status</i> – 0 (OFF), 1 (ON)			
Notes			
This command sets up the NTP server.			
Example			
Set time server with IP address of 128.138.140.44 to ON: #TIME-SRV 1, 128.138.140.44,0,1<CR>			

UART

Functions		Permission	Transparency
Set:	UART	Administrator	Public
Get:	UART?	End User	Public
Description		Syntax	
Set:	Set port tunneling UART configuration	# UART <code>[SP]</code> <i>baud_rate,data_bits,parity,stop_bits</i> <code>[CR]</code>	
Get:	Get port tunneling UART configuration	# UART? <code>[SP]</code>	
Response			
~ <code>[nn]</code> @ UART <code>[SP]</code> <i>baud_rate,data_bits,parity,stop_bits</i> <code>[SP]</code> OK <code>[CR LF]</code>			
Parameters			
baud_rate – 1200, 2400, 4800, 9600, 19200, 38400, 57600, 115200			
data_bits – 5 to 8 data bits			
parity – none, odd, even, mark, space, n, o, e, m, s			
stop_bits – 1, 2 stop bits			
K-Config Example			
Set baud rate to 9600, 8 data bits, parity to none and stop bit to 1: `#UART 9600,8,node,1",0x0D`			

I/O Gateway Commands

Command	Description
COM-ROUTE	Set/get tunneling port routing
ETH-TUNNEL	Get opened tunnel parameters
FV	Set/get tunneling mode
GPIO-CFG	Set/get HW GPIO configuration
GPIO-STATE	Set/get HW GPIO state
GPIO-STEP	Set/get HW GPIO step
GPIO-THR	Set/get HW GPIO threshold voltage
GPIO-VOLT	Get HW GPIO voltage level
IR-SND	Send IR command to port
IR-STOP	Send IR stop command to port
RELAY-STATE	Set/get relay state

COM-ROUTE

Command Name	Permission	Transparency
Set: -	-	-
Get: COM-ROUTE?	End User	Internal
Description	Syntax	
Set: Set tunneling port routing	#COM-ROUTE <code>[SP]</code> <i>COM_Num, portType, ETHPort, ETH_rep_en, TCP_keep_alive_timing</i> <code>[CR]</code>	
Get: Get tunneling port routing	#COM-ROUTE? <code>[SP]</code> <i>COM_Num</i> <code>[CR]</code>	
Response		
<code>~nn@COM-</code> ROUTE <code>[SP]</code> <i>COM_Num, portType, ETHPort, ETH_rep_en, TCP_keep_alive_timing</i> <code>[CR LF]</code>		
Parameters		
<i>COM_Num</i> - 1 (DATA RS-232), 2 (HDBT OUT 1), * (get all route tunnels) <i>portType</i> - 1 (UDP), 2 (TCP) <i>ETHPort</i> - TCP/UDP port number <i>ETH_rep_en</i> - 1 (COM port sends replies to new clients), 0 (COM port does not send replies to new clients) <i>TCP_keep_alive_timing</i> - 0 to 3600 seconds - every x seconds the device sends an empty string to TCP client ("/0")		
Notes		
This command sets tunneling port routing. Every com port can send or receive data from the ETH port. All com ports can be configured to the same ETH port.		
K-Config Example		
Set tunnel port 1 routing: "#COM-ROUTE 1,2,5001,0,40",0x0D		

ETH-TUNNEL?

Command Name		Permission	Transparency
Set:	-	-	-
Get:	ETH-TUNNEL?	Administrator	Internal
Description		Syntax	
Set:			
Get:	Get open tunnel parameters	# ETH-TUNNEL? <input type="text"/> <i>TunnelId</i> <input type="text"/>	
Response			
~ <input type="text"/> <input type="text"/> @ ETH- TUNNEL <input type="text"/> <i>TunnelId, ComNum, PortType, EthPort, EthIp, RemotPort, EthRepEn, Wired</i> <input type="text"/> <input type="text"/>			
Parameters			
<i>TunnelId</i> – 1 (RS-232), 2 (HDBT OUT 1), * (get all open tunnels) <i>ComNum</i> – UART number <i>portType</i> – TCP, UDP <i>ETHPort</i> – TCP/UDP port number <i>EthIp</i> – client IP address <i>RemotPort</i> – remote port number <i>EthRepEn</i> – 1 (COM port sends replies to new clients), 0 (COM port does not send replies to new clients) <i>Wired</i> – 1 (wired connection), 0 (not a wired connection)			
K-Config Example			
Set baud rate to 9600, 8 data bits, parity to none and stop bit to 1: `#ETH-TUNNEL? *", 0x0D`			

FV

Command Name		Permission	Transparency
Set:	FV	End User	Public
Get:	FV?	End User	Public
Description		Syntax	
Set:	Set data tunneling mode	# FV <input type="text"/> <i>output, mode</i> <input type="text"/>	
Get:	Get data tunneling mode	# FV? <input type="text"/> <i>output</i> <input type="text"/>	
Response			
~ <input type="text"/> <input type="text"/> @ FV <input type="text"/> <i>1, mode</i> <input type="text"/> <input type="text"/> <input type="text"/>			
Parameters			
<i>output</i> – 1 (HDBT OUT 1) <i>mode</i> – 0 (data connected to MCU, direct control), 1 (Data follows video)			
K-Config Example			
Set set data tunneling to follow video: `#FV 1, 1", 0x0D`			

GPIO-CFG

Command Name		Permission	Transparency
Set:	GPIO-CFG	End User	Public
Get:	GPIO-CFG?	End User	Public
Description		Syntax	
Set:	Set HW GPIO configuration	#GPIO-CFG ^[SP] <i>HwGpioNumber, HwGpioType, HwGpioDir, Pullup</i> ^[CR]	
Get:	Get HW GPIO configuration	#GPIO-CFG? ^[SP] <i>HwGpioNumber</i> ^[CR]	
Response			
~ ^[nn] @GPIO-CFG ^[SP] <i>HwGpioNum, HwGpioType, HwGpioDir</i> ^[CR LF]			
Parameters			
<i>HwGpioNum</i> – 1 (GPIO 1), 2 (GPIO 2)			
<i>HwGpioType</i> – hardware GPIO type: 0 (Analog), 1 (Digital)			
<i>HwGpioDir</i> – hardware GPIO direction: 0 (Input), 1 (Output)			
<i>Pullup</i> – enable/disable pull-up: 0 (Disable), 1 (Enable)			
K-Config Example			
Set GPIO 1 configuration to digital in with pull-up: "#GPIO-CONFIG 1,1,0,1",0x0D			

GPIO-STATE

Command Name		Permission	Transparency
Set:	GPIO-STATE	End User	Public
Get:	GPIO-STATE?	End User	Public
Description		Syntax	
Set:	Set HW GPIO state	#GPIO-STATE ^[SP] <i>HwGpioNumber, HwGpioState</i> ^[CR]	
Get:	Get HW GPIO state	#GPIO-STATE? ^[SP] <i>HwGpioNumber</i> ^[CR]	
Response			
~ ^[nn] @GPIO-STATE ^[SP] <i>HwGpioNum, HwGpioState</i> ^[CR LF]			
Parameters			
<i>HwGpioNum</i> – 1 (GPIO 1), 2 (GPIO 2)			
<i>HwGpioState</i> – hardware GPIO state: 0 (Low), 1 (High) See note below			
Notes			
<i>GPIO-STATE?</i> can only be sent in digital out mode and the answer is 0=Low, 1=High. In all other modes an error message is sent. The device uses this command to notify the user of any change regarding the step and voltage in: In digital mode the answer is 0 (low), 1 (high) In analog mode the answer is 0 to 100			
K-Config Example			
Set GPIO 2 to High: "#GPIO-STATE 2,1",0x0D			

GPIO-STEP

Command Name		Permission	Transparency
Set:	GPIO-STEP	End User	Public
Get:	GPIO-STEP?	End User	Public
Description		Syntax	
Set:	Set HW GPIO step	#GPIO-STEP[SP]HwGpioNumber,Step[CR]	
Get:	Get HW GPIO step	#GPIO-STEP?[SP]HwGpioNumber[CR]	
Response			
~[nn]@GPIO-STEP[SP]HwGpioNumber,NumOfStep,CurrentStep[CR LF]			
Parameters			
<i>HwGpioNum</i> – 1 (GPIO 1), 2 (GPIO 2)			
<i>NumOfStep</i> – for Digital In GPIO: 0 (Low), 1 (High)			
<i>CurrentStep</i> – the actual step depending on the measured voltage			
Notes			
In Digital In mode the response is 2			
In Analog In mode the response is 1 to 100			
In other modes an error is returned.			
K-Config Example			
Set GPIO 2 (set to Analog In) configuration step to 38mV: "#GPIO-STEP 2,38",0x0D			

GPIO-THR

Command Name		Permission	Transparency
Set:	GPIO-THR	End User	Public
Get:	GPIO-THR?	End User	Public
Description		Syntax	
Set:	Set HW GPIO voltage levels	#GPIO-THR[SP]HwGpioNumber,LowLevel,HighLevel[CR]	
Get:	Get HW GPIO voltage levels	#GPIO-THR?[SP]HwGpioNumber[CR]	
Response			
~[nn]@GPIO-THR[SP]HwGpioNumber,LowLevel,HighLevel[CR LF]			
Parameters			
<i>HwGpioNum</i> – 1 (GPIO 1), 2 (GPIO 2)			
<i>LowLevel</i> – voltage 500 to 28000 millivolts			
<i>HighLevel</i> – voltage 2000 to 30000 millivolts			
K-Config Example			
Set GPIO 2 to a low level of 800mV and a high level of 2200mV: "#GPIO-THR 2,800,2200",0x0D			

GPIO-VOLT?

Command Name		Permission	Transparency
Set:	-	-	-
Get:	GPIO-VOLT?	End User	Public
Description		Syntax	
Set:			
Get:	Get voltage levels of HW GPIO	#GPIO-VOLT? [SP]HwGpioNumber [CR]	
Response			
~nn@GPIO-VOLT [SP]HwGpioNumber, Voltage [CR LF]			
Parameters			
HwGpioNum – 1 (GPIO 1), 2 (GPIO 2)			
Voltage – voltage 0 to 30000 millivolts			
Notes			
This command is not available in digital out mode			
K-Config Example			
Get GPIO 1 voltage: "#GPIO-VOLT? 1", 0x0D			

IR-SND

Command Name		Permission	Transparency
Set:	IR-SND	End User	Public
Get:	-	-	-
Description		Syntax	
Set:	Send IR command to port	#IR-SND [SP]PortNum, Cmdid, CmdName, Repeat, TotalPackages, PackageNum, <pronto command...> [CR]	
Get:	-	-	
Response			
~nn@IR-SND [SP]PortNum, Cmdid, CmdName, Status [CR LF]			
Parameters			
Port_Num – 1 (IR port 1), 2 (IR port 2), 3 (IR port 3), 4 (IR port 4), * (broadcasts to all ports)			
Cmd_id – serial number of command for flow control and response commands from device			
CmdName – command name (length limit 15 chars)			
Repeat – number of times the IR command is transmitted (limited to 50; repeats > 50 are truncated to 50), default = 1			
Total_packages – number of messages the original command was divided into, 1 (Default)			
Package_num – chunk serial number (only valid when Total_packages > 1)			
Pronto_command – Pronto format command (in HEX format, no leading zeros, no '0x' prefix)			
Status – 0 (Sent), 1 (Stop), 2 (Done), 3 (Busy), 4 (Wrong Parameter), 5 (Nothing to Stop), 6 (Start), 7 (Timeout), 8 (Error)			
K-Config Example			
Send IR command via IR Port 2 (the command number is set to 3 it should be repeated 4 times the total packages is 5 and package 2 is sent: "#IR-SEND 2,3, command name,4,5,2,pronto format", 0x0D			

IR-STOP

Command Name		Permission	Transparency
Set:	IR-STOP	End User	Public
Get:	-	-	-
Description		Syntax	
Set:	Send IR stop command to port	# IR-STOP [SP] <i>PortNum, Cmdid, CmdName</i> [CR]	
Get:	-	-	
Response			
~ <i>nn</i> @ IR-STOP [SP] <i>PortNum, Cmdid, CmdName, Status</i> [CR LF]			
Parameters			
<i>Port_Num</i> – 1 (IR port 1), 2 (IR port 2), 3 (IR port 3), 4 (IR port 4), * (broadcasts to all ports)			
<i>Cmd_id</i> – serial number of command for flow control and response commands from device			
<i>CommandName</i> – a string, the alias of the IR command. The controlling device is responsible for sending the correct name			
<i>Status</i> – 0 (Sent), 1 (Stop), 2 (Done), 3 (Busy), 4 (Wrong Parameter), 5 (Nothing to Stop), 6 (Start), 7 (Timeout), 8 (Error)			
K-Config Example			
Send IR stop command to IR Port 2: "#IR-STOP 2,1,power",0x0D			

RELAY-STATE

Command Name		Permission	Transparency
Set:	RELAY-STATE	End User	Public
Get:	RELAY-STATE?	End User	Public
Description		Syntax	
Set:	Set relay state	# RELAY-STATE [SP] <i>RelayNumber, RelayState</i> [CR]	
Get:	Get relay state	# RELAY-STATE? [SP] <i>RelayNumber</i> [CR]	
Response			
~ <i>nn</i> @ RELAY-STATE [SP] <i>RelayNum, RelayState</i> [CR LF]			
Parameters			
<i>RelayNumber</i> – 1 (Relay 1), 2 (Relay 2)			
<i>RelayState</i> – 0 (open), 1 (close)			
K-Config Example			
Set relay 2 to closed: "#RELAY-STATE 2,1",0x0D			

Step-in Commands

Command	Description
PROG-ACTION	Set/get step-in button action list

PROG-ACTION

Command Name		Permission	Transparency
Set:	PROG-ACTION	End user	Public
Get:	PROG-ACTION?	End user	Public

Description		Syntax
Set:	Set step-in button action bitmap	#PROG-ACTION ^[SP] <i>type,port_id,button_id,actions_bitmap</i> ^[CR]
Get:	Get step-in button action bitmap	#PROG-ACTION? ^[SP] <i>port_type,port_id,button_id</i> ^[CR]

Response

```
~nn@PROG-ACTION[SP]port_type,port_id,button_id,actions_bitmap[CR LF]
```

Parameters

port_type – 0 (input)

port_id – 1 (Input 1), 2 (Input 2), 3 (Input 3), 4 (Input 4), 5 (Input 5), 6 (Input 6)

button_id – external programmable button ID (the Step-in button number on the slave device)

actions_bitmap – bitmap representing actions to perform after receiving *button_id*. format:

XXXX...X, where X is a hex digit. The binary form of every hex digit represents actions from the tab.

Setting '1' says that the corresponding action must be executed: 0 (echo controller), 1 (step-in HDBT), 2 (step-in HDMI)

Notes

Programs matrix action as a response for external event (programmable button pressed)

K-Config Example

Set step-in button actions on input 3:

```
"#PROG-ACTION 0,3,1,0x07",0x0D
```

The warranty obligations of Kramer Electronics Inc. ("Kramer Electronics") for this product are limited to the terms set forth below:

What is Covered

This limited warranty covers defects in materials and workmanship in this product.

What is Not Covered

This limited warranty does not cover any damage, deterioration or malfunction resulting from any alteration, modification, improper or unreasonable use or maintenance, misuse, abuse, accident, neglect, exposure to excess moisture, fire, improper packing and shipping (such claims must be presented to the carrier), lightning, power surges, or other acts of nature. This limited warranty does not cover any damage, deterioration or malfunction resulting from the installation or removal of this product from any installation, any unauthorized tampering with this product, any repairs attempted by anyone unauthorized by Kramer Electronics to make such repairs, or any other cause which does not relate directly to a defect in materials and/or workmanship of this product. This limited warranty does not cover cartons, equipment enclosures, cables or accessories used in conjunction with this product.

Without limiting any other exclusion herein, Kramer Electronics does not warrant that the product covered hereby, including, without limitation, the technology and/or integrated circuit(s) included in the product, will not become obsolete or that such items are or will remain compatible with any other product or technology with which the product may be used.

How Long this Coverage Lasts

The standard limited warranty for Kramer products is seven (7) years from the date of original purchase, with the following exceptions:

1. All Kramer VIA hardware products are covered by a standard three (3) year warranty for the VIA hardware and a standard three (3) year warranty for firmware and software updates.
2. All Kramer fiber optic cables, adapter-size fiber optic extenders, active cables, cable retractors, all Kramer speakers and Kramer touch panels are covered by a standard one (1) year warranty.
3. All Kramer Cobra products, all Kramer Calibre products, all Kramer Minicom digital signage products, all HighSecLabs products, all streaming, and all wireless products are covered by a standard three (3) year warranty.
4. All Sierra Video MultiViewers are covered by a standard five (5) year warranty.
5. Sierra switchers & control panels are covered by a standard seven (7) year warranty (excluding power supplies and fans that are covered for three (3) years).
6. K-Touch software is covered by a standard one (1) year warranty for software updates.
7. All Kramer passive cables are covered by a ten (10) year warranty.

Who is Covered

Only the original purchaser of this product is covered under this limited warranty. This limited warranty is not transferable to subsequent purchasers or owners of this product.

What Kramer Electronics Will Do

Kramer Electronics will, at its sole option, provide one of the following three remedies to whatever extent it shall deem necessary to satisfy a proper claim under this limited warranty:

1. Elect to repair or facilitate the repair of any defective parts within a reasonable period of time, free of any charge for the necessary parts and labor to complete the repair and restore this product to its proper operating condition. Kramer Electronics will also pay the shipping costs necessary to return this product once the repair is complete.
2. Replace this product with a direct replacement or with a similar product deemed by Kramer Electronics to perform substantially the same function as the original product.
3. Issue a refund of the original purchase price less depreciation to be determined based on the age of the product at the time remedy is sought under this limited warranty.

What Kramer Electronics Will Not Do Under This Limited Warranty

If this product is returned to Kramer Electronics or the authorized dealer from which it was purchased or any other party authorized to repair Kramer Electronics products, this product must be insured during shipment, with the insurance and shipping charges prepaid by you. If this product is returned uninsured, you assume all risks of loss or damage during shipment. Kramer Electronics will not be responsible for any costs related to the removal or re-installation of this product from or into any installation. Kramer Electronics will not be responsible for any costs related to any setting up this product, any adjustment of user controls or any programming required for a specific installation of this product.

How to Obtain a Remedy Under This Limited Warranty

To obtain a remedy under this limited warranty, you must contact either the authorized Kramer Electronics reseller from whom you purchased this product or the Kramer Electronics office nearest you. For a list of authorized Kramer Electronics resellers and/or Kramer Electronics authorized service providers, visit our web site at www.kramerav.com or contact the Kramer Electronics office nearest you.

In order to pursue any remedy under this limited warranty, you must possess an original, dated receipt as proof of purchase from an authorized Kramer Electronics reseller. If this product is returned under this limited warranty, a return authorization number, obtained from Kramer Electronics, will be required (RMA number). You may also be directed to an authorized reseller or a person authorized by Kramer Electronics to repair the product.

If it is decided that this product should be returned directly to Kramer Electronics, this product should be properly packed, preferably in the original carton, for shipping. Cartons not bearing a return authorization number will be refused.

Limitation of Liability

THE MAXIMUM LIABILITY OF KRAMER ELECTRONICS UNDER THIS LIMITED WARRANTY SHALL NOT EXCEED THE ACTUAL PURCHASE PRICE PAID FOR THE PRODUCT. TO THE MAXIMUM EXTENT PERMITTED BY LAW, KRAMER ELECTRONICS IS NOT RESPONSIBLE FOR DIRECT, SPECIAL, INCIDENTAL OR CONSEQUENTIAL DAMAGES RESULTING FROM ANY BREACH OF WARRANTY OR CONDITION, OR UNDER ANY OTHER LEGAL THEORY. Some countries, districts or states do not allow the exclusion or limitation of relief, special, incidental, consequential or indirect damages, or the limitation of liability to specified amounts, so the above limitations or exclusions may not apply to you.

Exclusive Remedy

TO THE MAXIMUM EXTENT PERMITTED BY LAW, THIS LIMITED WARRANTY AND THE REMEDIES SET FORTH ABOVE ARE EXCLUSIVE AND IN LIEU OF ALL OTHER WARRANTIES, REMEDIES AND CONDITIONS, WHETHER ORAL OR WRITTEN, EXPRESS OR IMPLIED. TO THE MAXIMUM EXTENT PERMITTED BY LAW, KRAMER ELECTRONICS SPECIFICALLY DISCLAIMS ANY AND ALL IMPLIED WARRANTIES, INCLUDING, WITHOUT LIMITATION, WARRANTIES OF MERCHANTABILITY AND FITNESS FOR A PARTICULAR PURPOSE. IF KRAMER ELECTRONICS CANNOT LAWFULLY DISCLAIM OR EXCLUDE IMPLIED WARRANTIES UNDER APPLICABLE LAW, THEN ALL IMPLIED WARRANTIES COVERING THIS PRODUCT, INCLUDING WARRANTIES OF MERCHANTABILITY AND FITNESS FOR A PARTICULAR PURPOSE, SHALL APPLY TO THIS PRODUCT AS PROVIDED UNDER APPLICABLE LAW. IF ANY PRODUCT TO WHICH THIS LIMITED WARRANTY APPLIES IS A "CONSUMER PRODUCT" UNDER THE MAGNUSON-MOSS WARRANTY ACT (15 U.S.C.A. §2301, ET SEQ.) OR OTHER APPLICABLE LAW, THE FOREGOING DISCLAIMER OF IMPLIED WARRANTIES SHALL NOT APPLY TO YOU, AND ALL IMPLIED WARRANTIES ON THIS PRODUCT, INCLUDING WARRANTIES OF MERCHANTABILITY AND FITNESS FOR THE PARTICULAR PURPOSE, SHALL APPLY AS PROVIDED UNDER APPLICABLE LAW.

Other Conditions

This limited warranty gives you specific legal rights, and you may have other rights which vary from country to country or state to state.

This limited warranty is void if (i) the label bearing the serial number of this product has been removed or defaced, (ii) the product is not distributed by Kramer Electronics or (iii) this product is not purchased from an authorized Kramer Electronics reseller. If you are unsure whether a reseller is an authorized Kramer Electronics reseller, visit our web site at www.kramerav.com or contact a Kramer Electronics office from the list at the end of this document.

Your rights under this limited warranty are not diminished if you do not complete and return the product registration form or complete and submit the online product registration form. Kramer Electronics thanks you for purchasing a Kramer Electronics product. We hope it will give you years of satisfaction.



P/N:



2900-300856

Rev:



1



SAFETY WARNING

Disconnect the unit from the power supply before opening and servicing

For the latest information on our products and a list of Kramer distributors, visit our Web site where updates to this user manual may be found.

We welcome your questions, comments, and feedback.