

Splitters

PRO SPLITTER 2 DS 20

Passive 1-In / 2-Out Signal Splitter
with MIDAS Transformer and
Extended Dynamic Range



- Line level splitter sends single input signal to 2 outputs
- Custom-built MIDAS transformer for highest signal integrity
- High headroom design offers superior sound quality
- Passive design does not require any power supply
- High quality Neutrik* XLR connectors
- Earth Lift switches for each output eliminates ground loop problems
- Fully transformer-isolated design ensures electrical separation
- Ultra-low noise and ultra-linear system for highest signal integrity
- Aluminium extrusion casing with protective rubber corners
- Compact and rugged design
- 10-Year Warranty Program*
- Designed and engineered in the U.K.

Building on KLARK TEKNIK's storied legacy of highest-quality signal processing devices, the DS 20 PRO SPLITTER 2 offers the same high headroom, dynamic response and sonic clarity you have come to expect. DS 20 is ideal for routing balanced XLR signals to multiple discrete destinations, including FOH and monitor consoles, active monitor loudspeakers, broadcast mixers, and more. A passive device, the DS 20 does not require any form of external power to complete its mission. Equipped with a custom-built MIDAS transformer, DS 20 is the perfect solution for a wide range of professional audio and multimedia applications.



*All third-party trademarks are the property of their respective owners. Their use neither constitutes a claim of the trademark nor affiliation of the trademark owners with MUSIC Tribe. Product names are mentioned solely as a reference for compatibility, effects and/or components. Warranty details can be found at musictribe.be.

Splitters

PRO SPLITTER 2 DS 20

Passive 1-In / 2-Out Signal Splitter
with MIDAS Transformer and
Extended Dynamic Range



MIDAS – The Legend in Sound Quality

Ever since its formation in the 1970s, MIDAS has had a long history of innovation and leadership in the world of audio mixing consoles. Employed by the most famous touring acts and installations world-wide, legendary MIDAS consoles such as the XL4 and Heritage H3000 quickly became industry standards.

MIDAS has earned their impeccable reputation due to their no-compromise approach for audio and build quality and in particular for their Award-winning products which are considered by industry experts as the industry's best sounding designs. Building on this legacy, the XL8 and PRO Series of Live Mixing Systems continue this great heritage of Award-winning audio quality.

KLARKTEKNIK is proud to incorporate MIDAS designed transformers for the ultimate in high-quality audio reproduction in both live and studio environments. Find out more about MIDAS' amazing legacy by visiting their extensive website.

High Headroom Design

A custom instrumentation-grade input circuit was designed for the DS 20 using advanced analogue design techniques to create the ideal input impedance match. This innovative approach provides an ultra low noise and ultra-linear system with a ruler-flat frequency response that ranges from 30 Hz to 45 kHz (± 3 dB).

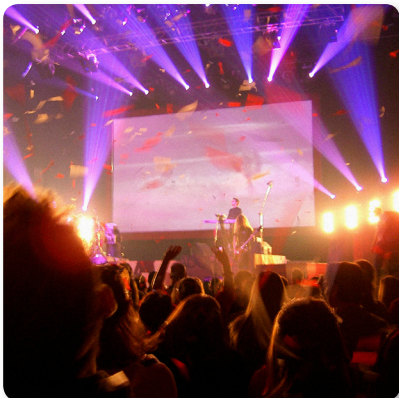

Connectivity & More

All of the Input and Output connections on the DS 20 feature genuine high quality Neutrik* XLR jacks for the ultimate in signal integrity. Dual independent Earth Lift switches are provided for both the Output A and Output B jacks, eliminating earth loops between equipment on different mains electricity supplies. DS 20's fully transformer-isolated design further ensures pristine performance – even in large-scale production environments.

Splitters

PRO SPLITTER 2 DS 20

Passive 1-In / 2-Out Signal Splitter
with MIDAS Transformer and
Extended Dynamic Range

Compact & Rugged Construction

The ultra-compact DS 20 is built to handle the rigours of life on the road via a thick and rugged aluminium extrusion that protects the electronics. The enclosure's roadworthiness is further enhanced through the implementation of sturdy rubber corner bumpers.



Versatility

The DS 20 PRO SPLITTER 2 allows you to send identical copies of balanced input signals to multiple discrete destinations thanks to its incredible frequency response of 30 Hz to 45 kHz (± 3 dB), MIDAS custom-design transformer for the ultimate in signal integrity and galvanic isolation, and highly intuitive design – all in a road-ready enclosure that stands ready for your input.

Visit your local [KLARKTEKNIK](#) supplier to try out the DS 20 PRO SPLITTER 2, or get yours online today. Your ears can tell the difference...

You Are Covered

We always strive to provide the best possible Customer Experience. Our products are made in our own [MUSIC Tribe](#) factory using state-of-the-art automation, enhanced production workflows and quality assurance labs with the most sophisticated test equipment available in the world. As a result, we have one of the lowest product failure rates in the industry, and we confidently back it up with a generous [Warranty program](#).



Splitters

PRO SPLITTER 2

DS 20

Passive 1-In / 2-Out Signal Splitter
with MIDAS Transformer and
Extended Dynamic Range

Dimensions

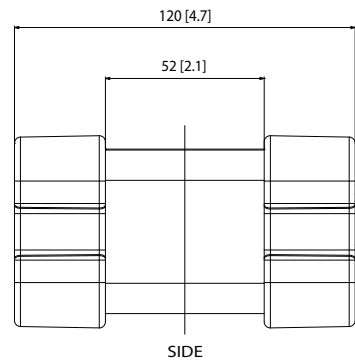
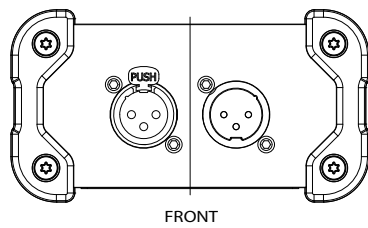
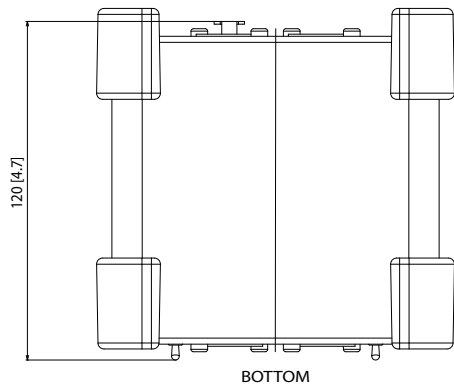
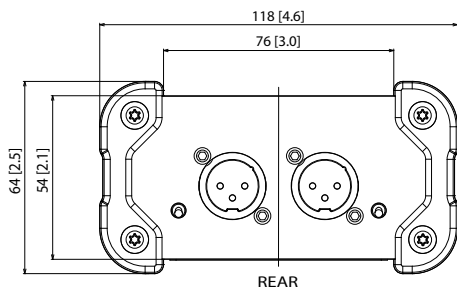

Splitters

PRO SPLITTER 2 DS 20

Passive 1-In / 2-Out Signal Splitter
with MIDAS Transformer and
Extended Dynamic Range

Technical Specifications

Audio Connections

Input	1 x XLR, balanced
Input impedance	1.9 k Ω , balanced
Thru	1 x XLR, balanced
Output A/B	2 x XLR, balanced

System

Frequency response	30 Hz to 45 kHz, ± 3 dB
Dynamic range	+124 dB
THD+N	< 0.03 % @ 1 kHz, +4 dBu
S/N ratio	> 100 dB @ +4 dBu

Dimension / Weight

Dimensions (W x D x H)	118 x 120 x 64 mm (4.6 x 4.7 x 2.5")
Weight	0.6 kg (1.3 lbs)

Splitters

PRO SPLITTER 2

DS 20

Passive 1-In / 2-Out Signal Splitter
with MIDAS Transformer and
Extended Dynamic Range

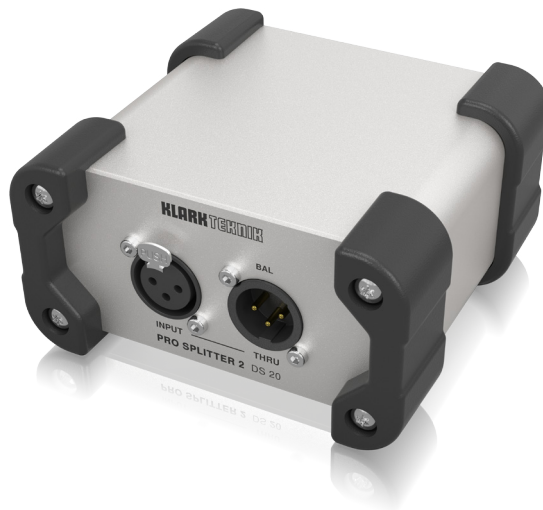

Splitters

PRO SPLITTER 2 DS 20

Passive 1-In / 2-Out Signal Splitter
with MIDAS Transformer and
Extended Dynamic Range



For service, support or more information contact the KLARK TEKNIK location nearest you:

Europe
MUSIC Tribe Brands UK Ltd.
Tel: +44156 273 2290
Email: CARECrea@music-group.com
CAREEnte@music-group.com
CARELife@music-group.com

USA/Canada
MUSIC Tribe Commercial NV Inc.
Tel: +1 702 800 8290
Email: CARECrea@music-group.com
CAREEnte@music-group.com
CARELife@music-group.com

Japan
MUSIC Tribe Services JP K.K.
Tel: +81 3 6231 0453
Email: CARECrea@music-group.com
CAREEnte@music-group.com
CARELife@music-group.com

MUSIC Tribe accepts no liability for any loss which may be suffered by any person who relies either wholly or in part upon any description, photograph, or statement contained herein. Technical specifications, appearances and other information are subject to change without notice. All trademarks are the property of their respective owners. MIDAS, KLARK TEKNIK, LAB GRUPPEN, LAKE, TANNOY, TURBOSOUND, TC ELECTRONIC, TC HELICON, BEHRINGER, BUGERA and COOLAUDIO are trademarks or registered trademarks of MUSIC Tribe Global Brands Ltd. © MUSIC Tribe Global Brands Ltd. 2018 All rights reserved.

KLARKTEKNIK