

The DIRECTOR[®] Model 46

Audio Multi-Room Controller

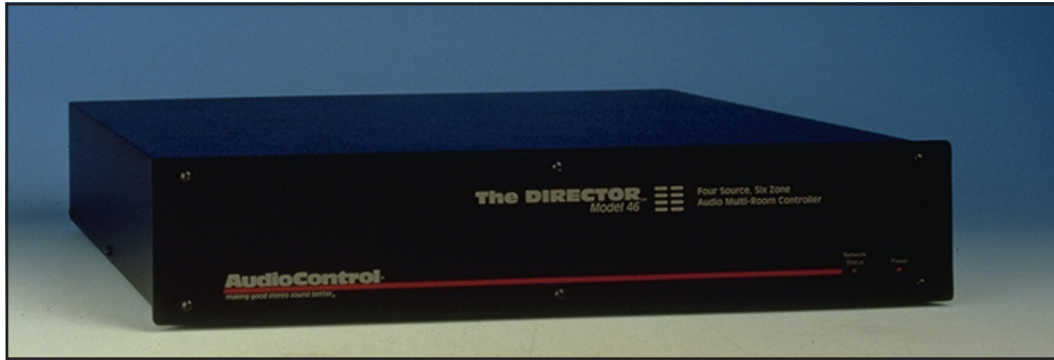

Stylish, Smart, and Simple

Four Source, Six Zone, Audio Multi-Room Controller

This is the next generation. The Director Model 46 has *four major* features you will not find on *any other* multi-room controller. It is attractive, easy to use, extremely flexible, and a reliable, truly professional, multi-room controller. This will make your day.

Stylish - Pleasing to the Eye

What part of the multi-room system controller does the homeowner and designer see and use? The wall stations. The Director Model 46 uses attractive, easy to use, flexible, *standard* control stations from *LiteTouch*. These stations, besides being complete, compact, and quick to wire, are available with custom buttons and in almost any finish imaginable: stainless steel, gold, bronze, black, white, wood, custom colors, or, they can be painted or papered on-site to match whatever the interior designer wants. At last, you can easily surpass the sophistication *and* cosmetic elegance of other systems in the house.

Smart - Programmed and Programmable

The Director Model 46 is easy to install as well. It comes pre-programmed and ready to run but also easy to custom program. This controller will do almost anything you decide with commands including programming min-max-default volume, chaining zones for common select but individual volume, grouping rooms, assignable machine control, and any button can be programmed to any function.

Simple - To Operate Every Time

The Director Model 46 is the brains between the homeowner and their system. There is simple ONE button access to all primary functions so that the custom-

ers will rave about the system to all of their friends. No more of these “hidden” functions and “double-push” sequences that work on odd numbered Thursdays. This ease is accomplished with programming smarts, not feature deletion. The user will not get confused.

Also, it is simple to wire with four conductor serial wiring and daisy-chained control stations. This is a real *automation system* unit not some modified consumer piece.

A Passion For Performance

Highest quality and innovative design have always been the hallmarks of AudioControl products. This unit is 100% designed and hand-built in America with pride. We stand behind that quality with a full FIVE year parts and labor warranty. Our components are performance certified at every critical point in the manufacturing process, and finally signed off by the person who built and *listened* to it.

The Director Model 46 joins a family of fine AudioControl audio components that has been winning awards since 1977. This highest quality product comes from a company that has won major awards for almost every product in its line. We don't believe in designing a product unless we can do it better than anyone else and for a great value. Don't just take our word for it, ask someone who owns an AudioControl product.

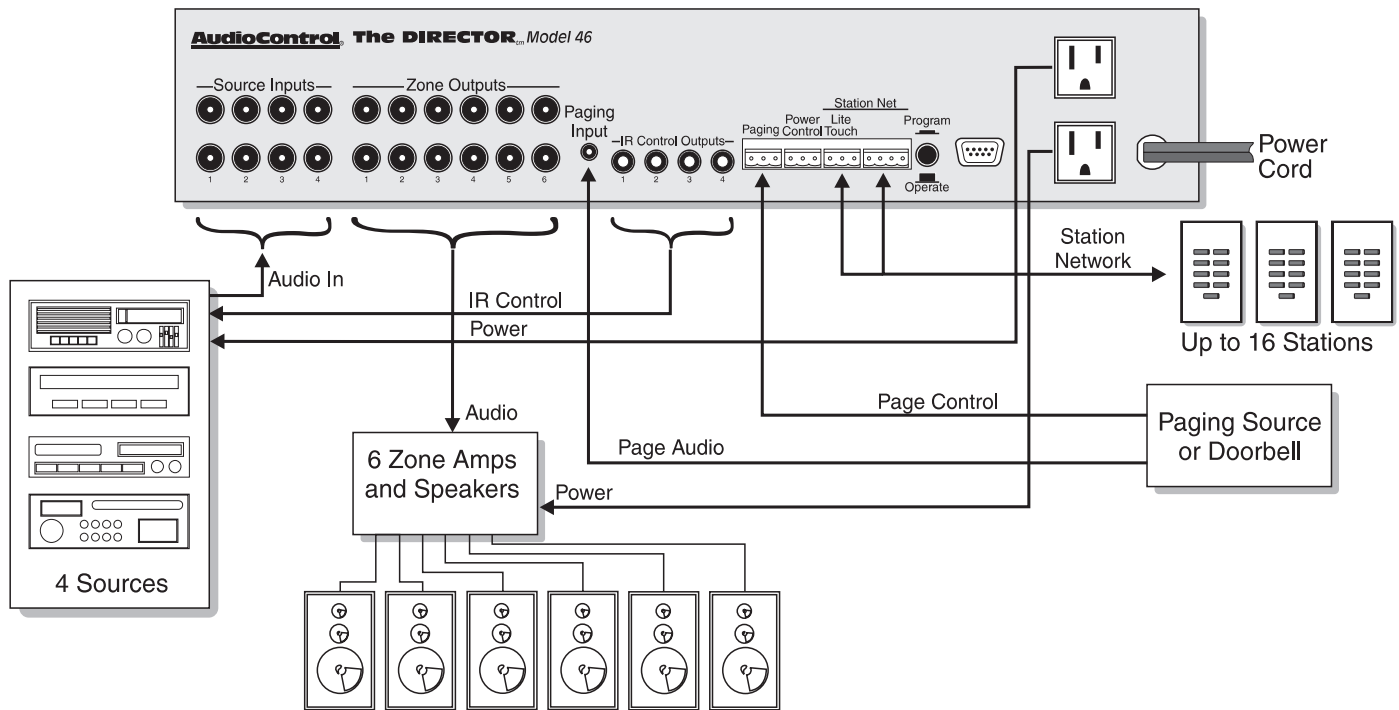

Features, Features and More (Advanced) Features

Expandable

The Director Model 46 routes 4 line level stereo sources to 6 different stereo zones with user control via wall station, IR, or serial data. It is stackable to a 4 source by 12 stereo zone system.

Flexible

Just some of the advanced flexibility of this product includes an ability to; split stereo zones into two mono zones with common source select but individual volume control, gang zones (like adjacent rooms) to coordinate source selection while retaining individual volume control, program bass and treble for each zone, turn off the whole system from any station, automatic turnoff of the whole system if no activity or all muted after a programmable amount of time, and to have multiple control stations per zone up to a total of 16 stations, per 6 zone system. Sorry, it doesn't wash windows.

Well Protected

For a product to be user-friendly and reliable, first it must survive installation. The Director Model 46 is short-circuit protected on the station ports, and protected throughout from static discharges, AC line surges, RF interference and everything else we have seen try to hurt products over the years. Don't forget the warranty is five years so we have to make it bulletproof.

Repeatable

The Director Model 46 is easy on installers also. The programmers interface makes it simple to save the system configuration onto a floppy disk. This is great for archiving customer's installations or duplicating your favorite system setup in that 500 unit housing development you just pre-wired. Just plug a PC into the Director and download the setup information in seconds.

Open System

With some multi-room control system, you must use only their components: amplifiers, tuners, and the like. The Director Model 46 is a completely open system allowing you to select the absolute best mix of components for the audio system you are designing.

All-in-One Box

This is a stand alone system that needs no other CCU or controller. Via its RS-232 port, it may be controlled by an external control system.

Easy to Wire

Pre-wire and retrofit is a snap because The Director wires to its control stations serially. The wiring is a simple 4 conductor and stations can be daisy chained or home run.

Ready to Run Out of the Box

The Director Model 46 comes to you pre-programmed with all machine command controls and with the remote control codes of hundreds of products already installed. If you need to add more codes, that is easy as well.

Paging Input

Want to have the door bell mute the stereo and ring through all the house's speakers? With the paging input this (and other more creative things) are possible. What other product at this price range gives you so much without additional boxes?

Switched Outlets

On the rear of the unit are two independently controlled AC switched outlets (for example, one to control sources and one to control amplifiers) along with a remote relay connector.

The First Audio System You Can Really Customer-ize

Single H-Station

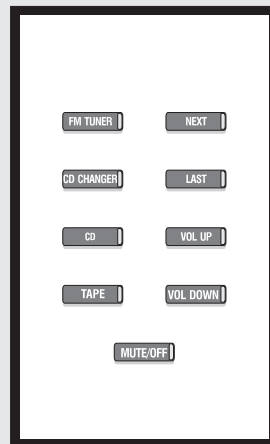

The basic control station is anything but basic. With thousands of possible station configurations the functions and cosmetics are customized for every installation. No one has to settle with somebody else's idea of a perfect station. Ease of use for both the customer and the installer.

Dual H-Station Audio and lighting controls in *one* station

Separate audio and lighting systems in a home don't have to look separate. By using *standard* LiteTouch lighting wall stations to control the Director Model 46 it's simple to unify the appearance of both the lighting and audio into a single wall station.

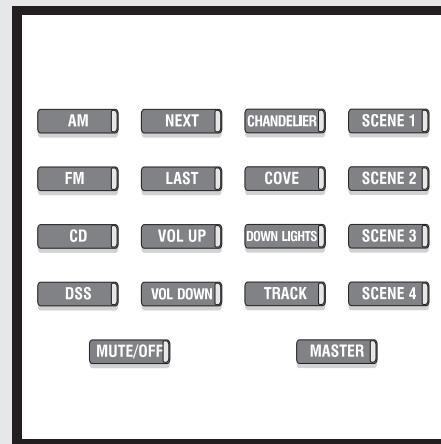

Dual S-Station Full Function Director Key Pad



By giving the system designer the ability to fully customize every button on a station, the Director Model 46 makes it easy to create shortcut keys to the homeowners favorite functions. Whether it's one touch for the morning newstalk radio station for the bathroom or for his and her CD changers, let your imagination run free.

FACEPLATE COLORS Premium Finishes: 24K Polished or 24K Satin Gold Plated Steel, Oil Polished Bronze. Standard Finishes: Black Anodized Aluminum, Gray Anodized Aluminum, Polished Stainless Steel, Satin Stainless Steel, White Primecoat Steel, Ivory Primecoat Steel, Satin Gold Anodized Aluminum. **BEZEL COLORS:** Primecoat, Black, Antique Gold, Stainless, Gold. **BUTTON COLORS:** Grey, Brown, Ivory, White, Black. **ENGRAVING:** Can be ordered to compliment or contrast the button color. H-series buttons allow one line of up to 10 letters. S-series buttons allow two lines of up to 8 letters each.

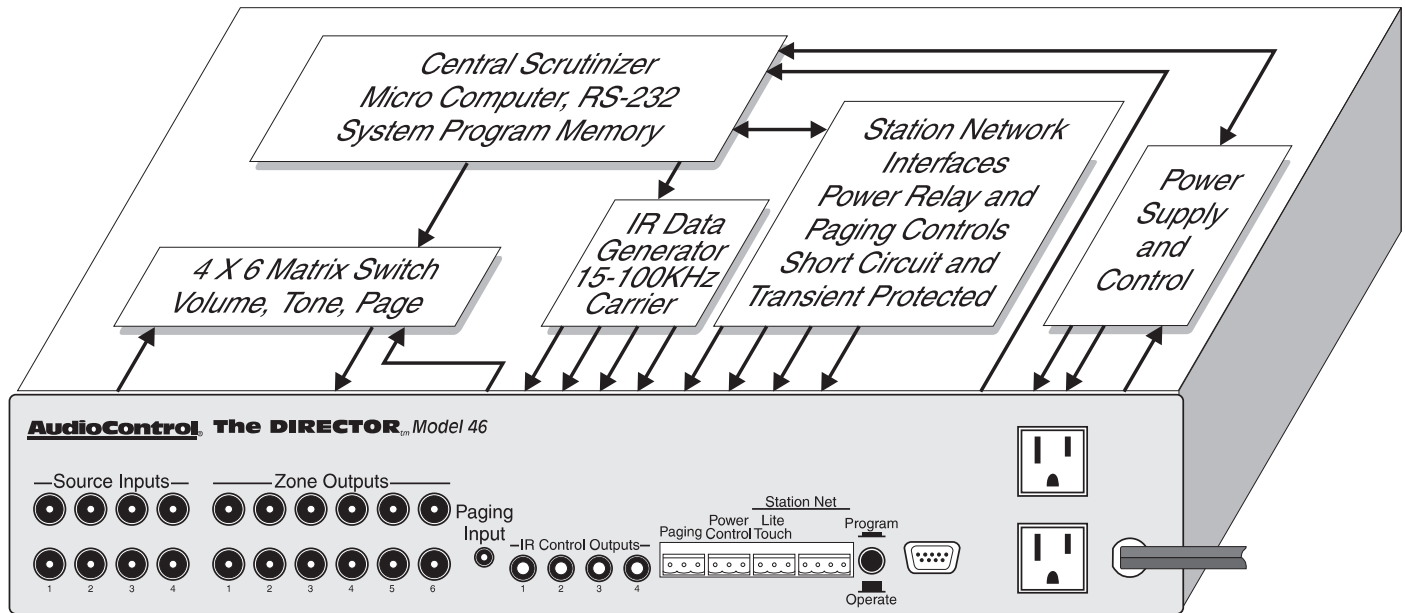

Specifications: The Director® Model 46

Component Type Line-Level Audio Multi-Room Controller
 Signal to Noise Greater than 95 dB (A-weighted, ref: 1 Vrms)
 Distortion 0.01% Total Harmonic Distortion
 Tone Controls Digitally Controlled, Baxandall Topology
 Bass ±12dB@ 100 Hz
 Treble ±12dB @ 10 kHz
 Level Control 78dB stereo, 38dB mono in 1.25 dB Steps
 Mute Level Programmable
 Source Inputs Four, stereo paired
 Connector RCA Jack
 Input Level 4Vrms Max - Programmable
 Input Impedance 100 kilohms
 Zone Outputs Six, stereo paired; or 12 mono zones
 (Stackable to 12 stereo, 24 mono zones)
 Connector RCA Jack
 Output Level 4 Vrms Max
 Output Impedance 220 ohms
 Source Control Outputs
 Type Infrared LED Flasher or Direct-wire w/interface
 Connectors Four, 1/8" mini-plug (Xantech compatible)
 Control Codes Major Brands Resident
 (Additional Downloadable)



Wall Control Stations Standard LiteTouch
 Network LiteTouch Serial Bus
 Mounting Full Sized Single Wallbox
 Recommended station wire 16 gauge, 4 conductor
 Control Buttons LiteTouch: up to 9
 Maximum Stations 16
 Paging Input Connector RCA
 Paging Input Level 500mVrms Nominal, 4 V Max
 Paging Control input Type-C Inverted Fusion Converter*
 Paging Mute Level Programmable
 Microprocessor: Dual CMOS MicroControllers
 Memory Non-Volatile EEPROM
 Programming Port DB-9F, RS-232 Serial
 Programming Fuel Double Tall Latté
 Port Settings Auto-Baud Rate, 8 bits, No Parity, 1 Stop bit
 System Protection Network Short-Circuit / Overload / Transient
 Electrical Line Voltage: 105-125Vac, 60Hz
 Power Consumption 1250 watts maximum
 Switched AC Outlets Two independent,
 1200watt combined maximum load
 Physical 3.5" h x 17.25" w x 12.5" d
 2 space (3.5") 19" rackmount optional
 Weight 12 pounds
 Warranty 5 Years or 2,629,440 Minutes
 Country of Origin U.S.A.

*contact closure or 8-35 VDC, 6-24 VAC

Due to continuing product improvement, specifications are subject to change without notice, like the Pacific Northwest weather. This fact sheet written on a really grey and gloomy day brightened by a great product.

©1995 All Rights Reserved AudioControl.

The Director is a trademark of AudioControl Division of Electronic Engineering and Manufacturing, Inc.

AudioControl®
 making good stereo sound better®
 22410 70th Ave W • Mountlake Terrace, WA 98043
 Phone 206-775-8461 • Fax 206-778-3166
 internet www.audiocontrol.com