

SIGMA

SIGMA CORPORATION

2-4-16 Kuriqi Asao-ku Kawasaki-shi,
Kanagawa 215-8530 Japan
Tel. 81-44-989-7437 Fax. 81-44-989-7448
www.sigma-global.com

▲ Caution: To ensure the correct and safe use of the product, be sure to read the User's Manual carefully prior to operation. 2015.8

dp

Quattro

Reinvention of camera,
reinvention of DP.



dp0
Quattro

Ultra-wide
14mm (21mm) F4

dp1
Quattro

Wide
19mm (28mm) F2.8

dp2
Quattro

Standard
30mm (45mm) F2.8

dp3
Quattro

Mid-tele
50mm (75mm) F2.8

SIGMA

Reinvention of camera,
reinvention of DP.

Explore a new world of photography with SIGMA dp.

From the moment we first considered making cameras, we at SIGMA have never stopped asking ourselves this question: “What parts and materials do we need to craft the best cameras possible?”

Photography is an art accessible to anyone with the desire. For this reason, we wanted to create a camera that would let anyone experience the true essence of photography. Give everyone the opportunity to take the perfect picture. A camera that is approachable. Convenient. Excellent. While no doubt being quite a bit different from the typical camera, it would make people simply love to take pictures. More than a goal, making this camera a reality was our passion.

Over ten years ago, we discovered something. Virtually unknown to the world at the time, it offered incredible resolution. Precise gradation. Gorgeous color. And breathtaking realism. It was the Foveon direct image sensor. At last, here was the image for which we'd been searching.

Sensing light directly to offer genuine high resolution, the Foveon direct image sensor produces highest-quality, full-bodied images. Inspired by this sensor, we featured it in the first-generation DP1, the world's first full-specification compact digital camera. In fact, the DP1 launched an entirely new category of camera, one that we can hardly imagine living without today.

Since the DP1, the SIGMA DP series has offered the best sensor and lens performance in an optimized package. Combining the image quality of a medium format camera with excellent portability, this revolutionary series has earned the praise and affection of photography lovers around the world.

Today, in the rapidly changing world of photography, we at SIGMA continue to ask ourselves another challenging question: “What kind of cameras can we create to revolutionize people's relationship with photography?”

The answer is a camera that embodies a modern, universal, and authentic philosophy. Our answer for today is the dp.



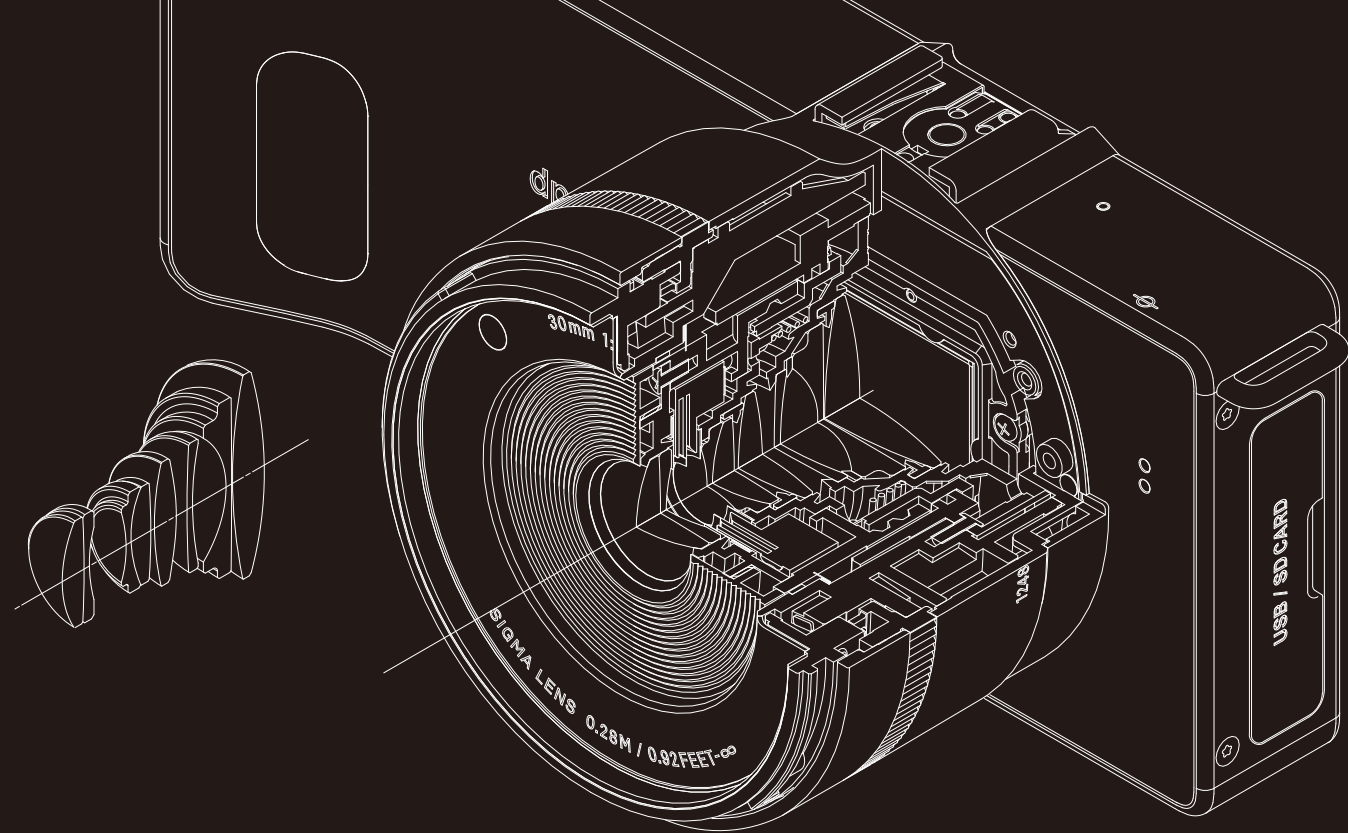

A dedication to full-bodied image quality— everything SIGMA represents in one camera.

Unique and without peer among image sensors, the Foveon direct image sensor is similar to traditional color film in that its multiple layers capture all of the information that visible light transmits. Vertical color separation technology produces incredibly rich color gradations, which in turn make possible texture and expressive power that are immediately apparent to the eye. Even when you are photographing an object with a single color, the sensor captures the full gradation perfectly, with no discordant jumps between lighter and darker areas. Proof that capturing color accurately one pixel at a time really makes a difference, these perfect gradations are at the heart of what we call “full-bodied image quality.”

While delivering this rich, colorful, ultra-high resolution that optimally replicates what you see in the real world, the new dp offers image files of a reasonable size in an easy-to-process format. To achieve this combination, we thoroughly rethought and redesigned every aspect of the camera, including the sensor, engine, lens, body, and interior layout. The result is a camera that carries on the dp tradition and gives you unprecedented image quality.

To a radical degree, the new-generation dp series embodies SIGMA's philosophy of creating cameras that produce works of art. Featuring the highest level of fundamental performance, this series unites artistic expression and daily experience as no other cameras can.

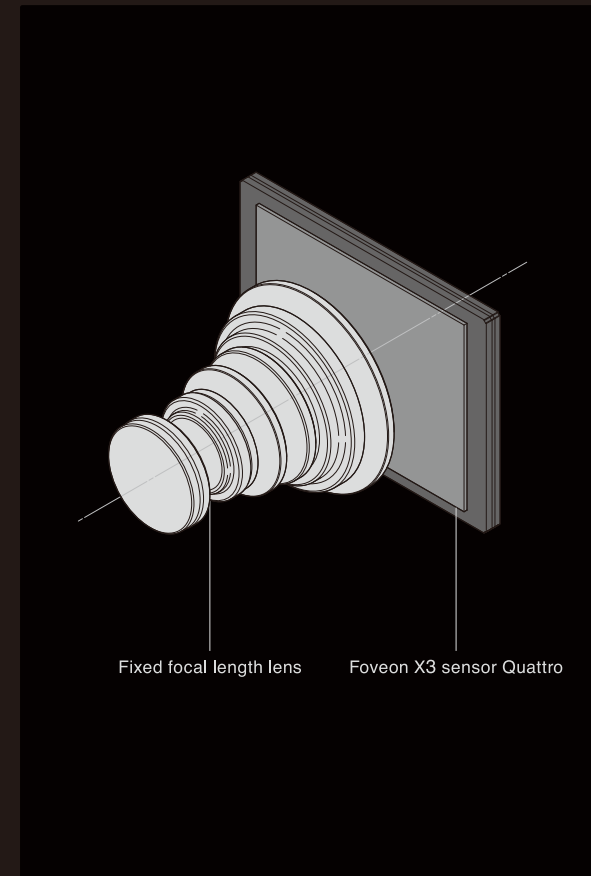

With every element optimized for lens and sensor performance, this camera is simple yet powerful

To deliver full-bodied image quality with all of its rich and colorful detail, we rethought and optimized every element of the camera. Including the ultra-high-resolution sensor, the top-performance lens, and every component involved in motion and operation. Unchanged from the first generation is a key element of the specification, the fixed focal length lens, which we selected as the optimal way to deliver the highest possible level of image quality.

The dp series is able to process high volumes of image data at a level similar to that of a high-end DSLR, and the shape, weight, layout, and other camera elements all come together in a compact body to deliver outstanding image quality. In addition, the dp series offers superior handling performance and highly intuitive operation. In summary, these features allow the photographer to concentrate fully on photography itself, leveraging the camera's potential to produce outstanding images.

In everyday life, the dp series lets photographers find unexpected opportunities for experiencing emotion and enjoying photography and personal expression in exciting new ways. It is an outwardly simple yet extremely powerful embodiment of SIGMA's philosophy of photography.



Tools that greatly expand the realm of photographic expression

To the dp Quattro lineup of wide-angle, standard, and medium telephoto, SIGMA now adds an ultra-wide-angle selection. Each camera in the series features a single fixed focal length lens and an exclusive body:

Ultra-wide-angle dp0: 14mm (equivalent to 21mm on a 35mm camera)

Wide-angle dp1: 19mm (equivalent to 28mm on a 35mm camera)

Standard dp2: 30mm (equivalent to 45mm on a 35mm camera)

Medium telephoto dp3: 50mm (equivalent to 75mm on a 35mm camera)

Take medium format-level quality with you wherever you go. The dp Quattro series is dedicated to providing you with amazing image quality and the power to create real works of art. The basic structure leverages the power of the fixed focal length to deliver outstanding photographic expression. The addition of the dp0 further sharpens this concept. As always, its ideal specification combines the ultimate sensor with the ultimate lens, which bring out the best possible performance in each other. An already rich series now offers even greater depth and breadth to those who love photography.

Awards



TIPA AWARDS 2014 : Best Design



IF DESIGN AWARD 2015 : Gold Award



GOOD DESIGN AWARD 2014 : Gold Award



dp0

Quattro

Ultra-minimal distortion.
Introducing extreme dp.

Outstanding resolution, rich expression of gradations, and excellent penetration of light to all four corners of the image. Generous in its use of advanced materials, the optical system features four FLD ("F" Low Dispersion) glass elements and two SLD (Special Low Dispersion) glass elements to minimize the chromatic aberration of magnification. A difficult-to-manufacture large-diameter aspheric lens sits first in the optical series, reducing distortion to less than 1%.* Such minimization is critical to ultra-wide-angle performance, and the dp0 takes photographs in which distortion is virtually undetectable to the eye. Designed to deliver an even wider angle of view than the dp1 and ultra-minimal distortion, the dp0 exemplifies the spirit of the dp Quattro series.

*At infinity focus

Foveon X3 direct image sensor

The world's only image capture system to use vertical color separation technology

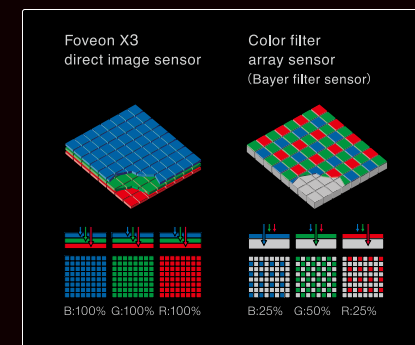

Starting with our very first digital camera, we have featured the Foveon direct image sensor, which offers radically better image quality than any other sensor available. Leveraging the light absorption characteristics of silicon, Modulation Transfer comprises three layers of photodiodes, each at a different depth within the silicon and each corresponding to a different RGB color. Since it is the only sensor to use this superior vertical color separation technology, it is also the world's only direct image sensor.

Almost all other image sensors are mosaic sensors, which use an array of RGB color filters in a single horizontal plane to capture color information. Each pixel is assigned only one of the three colors and cannot capture all three colors at once. In contrast, the Foveon direct image sensor captures color vertically, recording hue, value, and chroma accurately and completely for each pixel.

TRUE III

Optimized for processing Foveon X3 Quattro direct image sensor data

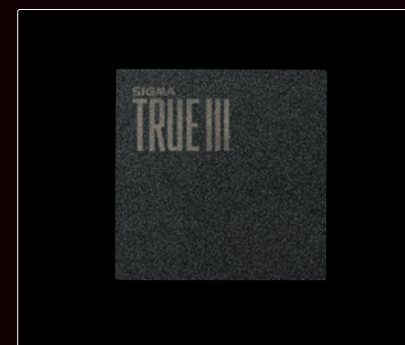

The new dp series cameras feature the new TRUE (Three-layer Responsive Ultimate Engine) III, an image processing engine we developed especially for the new-generation Foveon X3 Quattro direct image sensor. This image processing engine has evolved in pace with our Foveon direct image sensor and incorporates all of the image processing expertise we have developed over the years. Offering 14-bit processing, it is the ideal engine for turning the sensor's rich and complex image data into finished photographs. The ultimate result is high-definition, 3D-like photographs with outstandingly rich color detail.

Dedicated high-performance lens

Outstanding optical performance featuring minimal aberrations for optimized photographic results



The dp lenses minimize optical aberrations and bring out the best performance from the Foveon X3 Quattro direct image sensor for optimized photographic results.

The wide-angle lens in the dp1 Quattro features FLD ("F" Low Dispersion) glass and other technologies to minimize optical aberrations. The standard lens in the dp2 Quattro builds on the high-performance lens of the well-received DP2 Merrill camera and offers F2.8 brightness at 30mm. The medium telephoto lens in the dp3 Quattro builds on the outstanding performance of the DP3 Merrill camera and offers F2.8 brightness on 50mm.

The dp0 features a newly developed ultra-wide-angle lens offering F4 brightness at 14mm (equivalent to 21mm on a 35mm camera). A worthy addition to the dp series, it delivers outstanding resolution, rich expression of gradations, and excellent penetration of light to all four corners of the image.

dp0

Quattro

14mm (21mm) F4

UPC code: 00-85126-93152-0

With its ultra-wide angle lens (equivalent to 21mm on a 35mm camera), the dp0 goes beyond the wide-angle dp1 to deliver a 91° angle of view and breathtaking perspective. It unlocks the door to incredible ultra-wide photographic expression.

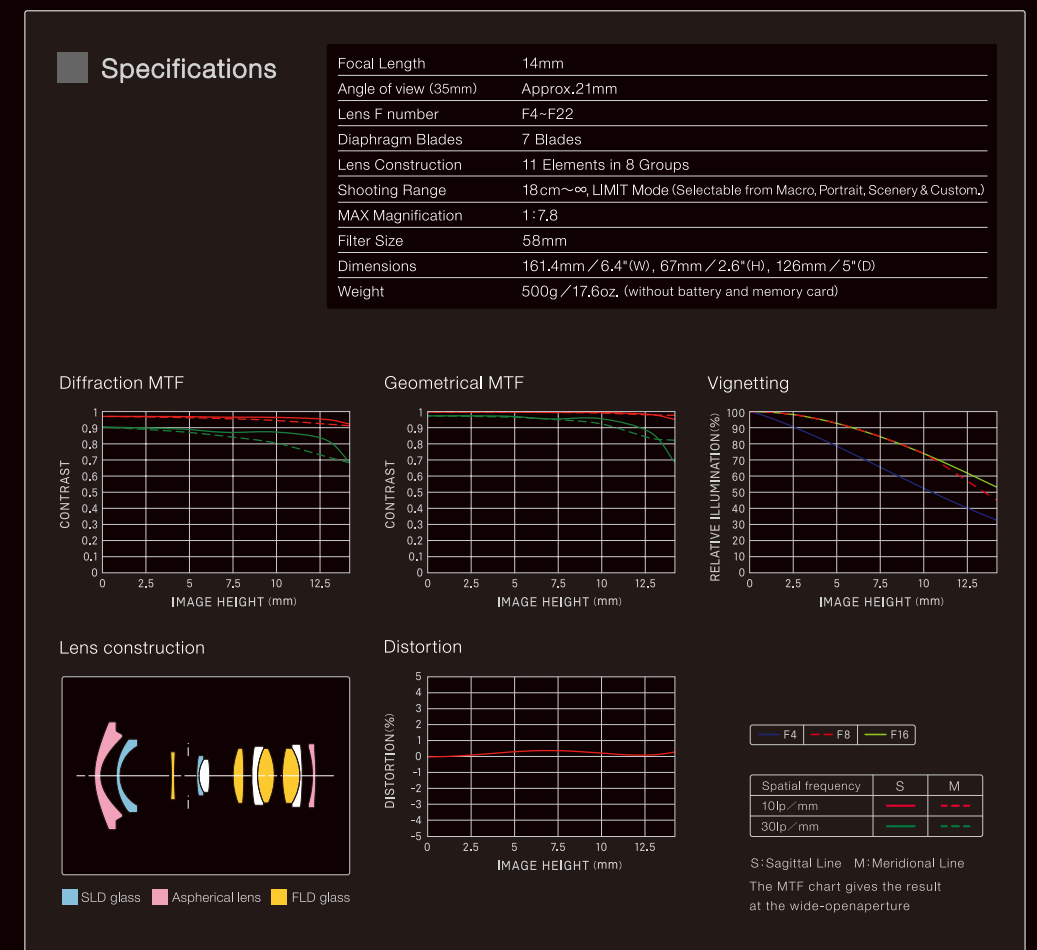

Front



Left



Back



Right



dp1

Quattro

19mm (28mm) F2.8

UPC code: 00-85126-93058-5

This wide-angle lens camera (equivalent to 28mm on a 35mm camera) offers broad and spacious perspective to produce dynamic and dramatic photographs.

Specifications

Focal Length	19mm
Angle of view (35mm)	Approx.28mm
Lens F number	F2.8-F16
Diaphragm Blades	9 Blades
Lens Construction	9 Elements in 8 Groups
Shooting Range	20cm~∞ LIMIT Mode (Selectable from Macro, Portrait, Scenery & Custom.)
MAX Magnification	1:8,3
Filter Size	58mm
Dimensions	161.4mm / 6.4"(W), 67mm / 2.6"(H), 87.1mm / 3.4"(D)
Weight	425g / 15oz. (without battery and memory card)

Diffraction MTF

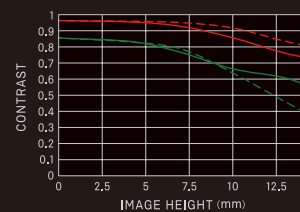

Geometrical MTF

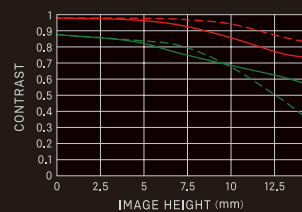

Vignetting

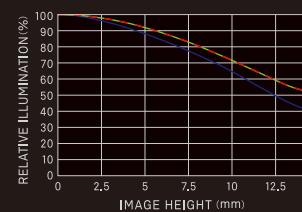

Lens construction

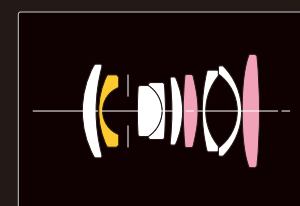

Aspherical lens FLD glass

Distortion

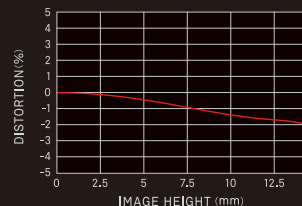

	F2.8	F5.6	F11
Spatial frequency	S	M	
10lp/mm	—	---	
30lp/mm	—	---	

S:Sagittal Line M:Meridional Line
The MTF chart gives the result at the wide-openaperture

dp2

Quattro

30mm (45mm) F2.8

UPC code: 00-85126-93025-7

This standard lens camera (equivalent to 45mm on a 35mm camera) offers perspective very close to human vision, allowing photographers to easily replicate the scenes they see with their own eyes.

Specifications

Focal Length	30mm
Angle of view (35mm)	Approx.45mm
Lens F number	F2.8-F16
Diaphragm Blades	9 Blades
Lens Construction	8 Elements in 6 Groups
Shooting Range	28cm~∞ LIMIT Mode (Selectable from Macro, Portrait, Scenery & Custom.)
MAX Magnification	1:7,6
Filter Size	58mm
Dimensions	161.4mm / 6.4"(W), 67mm / 2.6"(H), 81.6mm / 3.2"(D)
Weight	410g / 14.5oz. (without battery and memory card)

Diffraction MTF

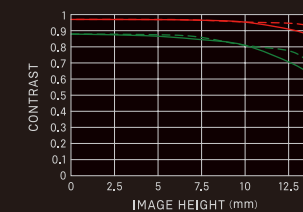

Geometrical MTF

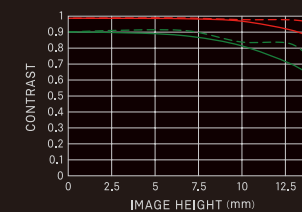

Vignetting

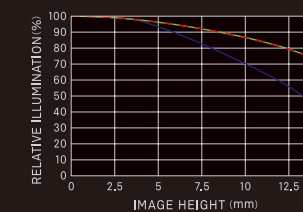

Lens construction

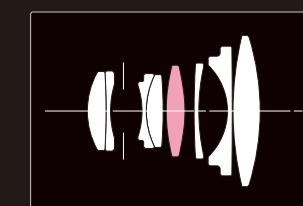

Aspherical lens

Distortion

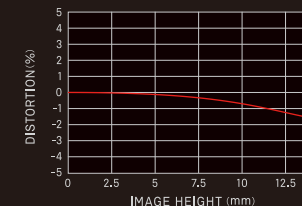

	F2.8	F5.6	F11
Spatial frequency	S	M	
10lp/mm	—	---	
30lp/mm	—	---	

S:Sagittal Line M:Meridional Line
The MTF chart gives the result at the wide-openaperture



Front



Left



Back



Right



Front



Left



Back



Right

dp3

Quattro

50mm (75mm) F2.8

UPC code: 00-85126-93117-9

This medium telephoto lens camera (equivalent to 75mm on a 35mm camera) emphasizes the presence of the subject and offers an outstanding crop effect, allowing photographers to express themselves freely and make a great impression.

Specifications

Focal Length	50mm
Angle of view (35mm)	Approx. 7.5mm
Lens F number	F2.8-F16
Diaphragm Blades	7 Blades
Lens Construction	10 Elements in 8 Groups
Shooting Range	22.6cm~∞ LIMIT Mode (Selectable from Macro, Portrait, Scenery & Custom)
MAX Magnification	1:3
Filter Size	58mm
Dimensions	161.4mm / 6.4"(W), 67mm / 2.6"(H), 101.8mm / 4"(D)
Weight	465g / 16.4oz. (without battery and memory card)

Diffraction MTF

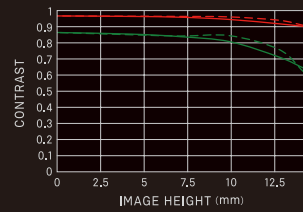

Geometrical MTF

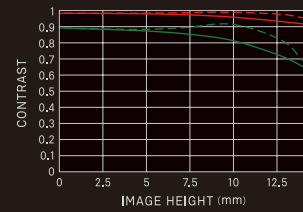

Vignetting

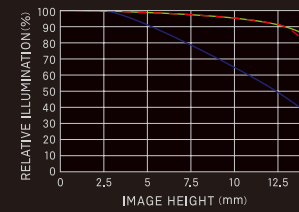

Lens construction

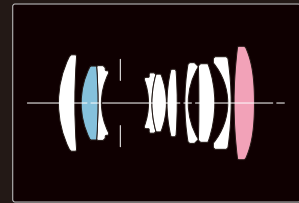

■ SLD glass ■ Aspherical lens

Distortion

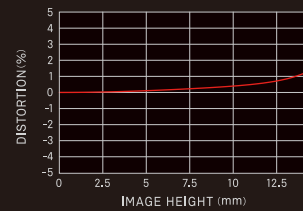

Spatial frequency	S	M
10lp/mm	---	---
30lp/mm	---	---

S: Sagittal Line M: Meridional Line
The MTF chart gives the result at the wide-open aperture



Front



Left



Back



Right

dp Quattro dp line specifications

Image Sensor	Foveon X3 Direct Image Sensor (CMOS)					
Image Sensor Size	23.5×15.7mm					
Color Photo Detectors	Effective Pixels: Approx. 29MP T(Top): 5,424×3,616 / M(Middle): 2,712×1,808 / B(Bottom): 2,712×1,808 Total Pixels: Approx. 33MP					
Storage Media	SD Card, SDHC Card, SDXC Card, Eye-Fi Card eyefi					
File Format	Lossless compression RAW (14-bit), JPEG (Exif 2.3), RAW+JPEG					
JPEG Image Quality	FINE, NORMAL, BASIC					
Aspect Ratio	21:9, 16:9, 3:2, 4:3, 7:6, 1:1					
Number of Recording Pixels	RAW	HIGH	T: 5,424×3,616	M: 2,712×1,808	B: 2,712×1,808	
		LOW	T: 2,704×1,808	M: 2,704×1,808	B: 2,704×1,808	
	[21:9] JPEG	SUPER-HIGH	7,680×3,296			
		HIGH	5,424×2,328			
		LOW	2,704×1,160			
		S-LO	1,920×816			
	[16:9] JPEG	SUPER-HIGH	7,680×4,320			
		HIGH	5,424×3,048			
		LOW	2,704×1,520			
		S-LO	1,920×1,080			
	[3:2] JPEG	SUPER-HIGH	7,680×5,120			
		HIGH	5,424×3,616			
		LOW	2,704×1,808			
		S-LO	1,920×1,280			
	[4:3] JPEG	SUPER-HIGH	6,816×5,120			
		HIGH	4,816×3,616			
		LOW	2,400×1,808			
		S-LO	1,696×1,280			
	[7:6] JPEG	SUPER-HIGH	6,352×5,120			
		HIGH	4,480×3,616			
		LOW	2,224×1,808			
		S-LO	1,584×1,280			
	[1:1] JPEG	SUPER-HIGH	5,120×5,120			
		HIGH	3,616×3,616			
		LOW	1,808×1,808			
		S-LO	1,280×1,280			
ISO Sensitivity	ISO100-ISO6400 (1/3 steps for appropriate sensitivity), AUTO: High limit, low limit setting is possible between ISO100-ISO6400. When using with flash, it changes depending on the low limit setting.					
White Balance	10 types (Auto, Auto (Lighting Source Priority), Daylight, Shade, Overcast, Incandescent, Fluorescent, Color Temperature, Flash, Custom)					
Color Mode	11 types (Standard, Vivid, Neutral, Portrait, Landscape, Cinema, Sunset Red, Forest Green, FOV Classic Blue, FOV Classic Yellow, Monochrome)					
Auto Focus Type	Contrast Detection Type					
AF Point	9 points select mode, Free move mode (It is possible to change the size of Focus Frame to Spot, Regular and Large.), Face Detection AF mode					
Focus Lock	Shutter release halfway-down position (AF lock can be done by AE lock button from menu setting)					
Metering Systems	Evaluative Metering, Center-Weighted Average Metering, Spot Metering					
Exposure Control System	(P) Program AE (Program Shift is possible), (S) Shutter Speed Priority AE, (A) Aperture Priority AE, (M) Manual					
Exposure Compensation	±3EV (1/3 stop increments)					
AE Lock	AE lock button					
Auto Bracketting	Appropriate, under, over; 1/3EV steps up to ±3EV for appropriate exposure					
Shutter Speed	1/2000*~30sec. (*Depending on the aperture value, shutter speed changes)					
Drive Modes	Single, Continuous, Self Timer (2sec./10sec.), Interval timer					
LCD Monitor Type	TFT color 3.0 inch LCD monitor					
LCD Pixels	Approx. 920,000 Pixels					
LCD Monitor Language	English / Japanese / German / French / Spanish / Italian / Chinese (Simplified) / Chinese (Traditional) / Korean / Russian / Nederlands / Polski / Português / Dansk / Svenska / Norsk / Suomi					
Interfaces	USB / Cable Release Switch					
Power	Li-ion Battery Pack BP-51, Battery Charger BC-51, AC Adapter SAC-6 (with DC Connector CN-21) (Optional)					
Battery Life	Approx. 200shots (+25°C)					
Accessories	Lens Cap (on the camera) / Hot shoe cover (on the camera) / Strap / Li-ion Battery BP-51 (2 pieces) / Battery Charger BC-51 / Battery Charger Cable / USB Cable / Instruction Manual					

Accessories fitting table

	dp0 <small>Quattro</small>	dp1 <small>Quattro</small>	dp2 <small>Quattro</small>	dp3 <small>Quattro</small>
ELECTRONIC FLASH (*1)	EF140S SA-STTL			
CONVERSION LENS	FT-1201			
VIEW FINDER	VF-51	VF-31	VF-41	
LENS HOOD	LH5-01	LH4-01	LH4-01	LH4-01 + HE1-01
LCD VIEW FINDER	LVF-01			
BASE GRIP	BG-11			
CAMERA CASE	HC-21			
CABLE RELEASE	CR-31			
AC ADAPTER	SAC-6			
FILTER (*2)	WR PROTECTOR (58mm) PROTECTOR (58mm) WR UV FILTER (58mm) WR CIRCULAR PL FILTER (58mm)			

*1: Cannot be attached with VIEW FINDER at the same time *2: The focus length will be extended to 67mm by attaching a CONVERTER 1.2x FT-1201.

dp Optional Accessories



EXTENSION HOOD (HE1-01)
UPC code: 00-85126-93135-3
HOOD SET (Hood Set)
UPC code: 00-85126-93136-0

Exclusively for the dp3 Quattro, the Extension Hood (HE1-01) can be used in combination with Lens Hood (LH4-01) on the dp3 Quattro to obtain an even better shading effect. Using Extension Hood (HE1-01) requires Lens Hood (LH4-01), and both are sold separately.



PETAL TYPE LENS HOOD (LH5-01)
(LH5-01 is supplied with dp0)
UPC code: 00-85126-93153-7

This lens hood blocks out extraneous light and reduces flare and ghosting. It is supplied with dp0 Quattro camera.

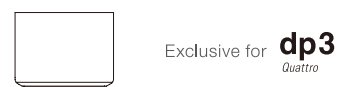

CONVERSION LENS (FT-1201)
UPC code: 00-85126-93131-5

This 1.2x teleconverter fits on the front of the lens of the dp3 Quattro. Designed exclusively for the dp3 Quattro, it maintains high-level performance while delivering outstanding image quality.



LENS HOOD (LH4-01)
UPC code: 00-85126-93051-6

This lens hood blocks out extraneous light and reduces flare and ghosting. It can be attached to the tip of the lens easily.



FILTER
 · SIGMA WR PROTECTOR: 58mm
UPC code: 00-85126-93092-9
 · SIGMA PROTECTOR: 58mm
UPC code: 00-85126-93105-6
 · SIGMA WR UV FILTER: 58mm
UPC code: 00-85126-93066-0
 · SIGMA WR CIRCULAR PL FILTER 58mm
UPC code: 00-85126-93079-0

A range of filters with a new concept that ensure their performance to the fullest.

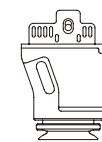

LCD VIEWFINDER (LVF-01)
UPC code: 00-85126-93120-9

Exclusively for dp series cameras, this viewfinder fits on the LCD monitor and cuts ambient light. By increasing the size of the monitor 2.5 times, it makes it easier to confirm the correct focus. Further, by allowing you to look into the viewfinder as though using an SLR camera, it takes holding performance to the next level.

Note: The magnification ratio was calculated based on the standard ratio measurement for a loupe.

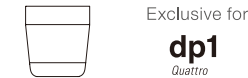

VIEWFINDER (VF-31)
UPC code: 00-85126-93115-5



VIEWFINDER (VF-41)
UPC code: 00-85126-93026-4



VIEWFINDER (VF-51)
UPC code: 00-85126-93150-6

This high performance Albada inverted Galilean type Finder mounts on the hot shoe. It offers a framing guide for deciding the composition without the color LCD monitor and accurate framing unaffected by external light condition.



CAMERA CASE (HC-21)
UPC code: 00-85126-93050-9

This jacket type camera case can be attached to the camera while photographing. It perfectly fits the camera, which improves the usability of the camera.



BASE GRIP (BG-11)
UPC code: 00-85126-93144-5

When it is attached to the screw hole on the bottom surface of the camera, it allows handgrip-style of shooting. It is compact and convenient and therefore very easy to carry. The bottom part of the Base Grip BG-11 has a screw hole so that it can attach directly to a tripod.



CABLE RELEASE (CR-31)
UPC code: 00-85126-93027-1

This cable release allows releasing the shutter without touching the camera by connecting it to camera USB terminal. It is useful when attaching the camera to a tripod, and releasing the shutter from a distance, or slow shutter. (Cable length: Approximately 1m)



ELECTRONIC FLASH (EF-140S SA-STTL)
UPC code: 00-85126-93028-8

This compact flash is exclusively for dp cameras and has a guide number of 14. Excellent for nighttime shots or daytime sync, this flash gives you optimal flexibility.