

RPS4

Redundant DC Power Supply



Follow Us On:



Fill in for your records:

Serial Number:

Purchase Date:

Important Safety Instructions



This symbol, wherever it appears, alerts you to the presence of uninsulated dangerous voltage inside the enclosure -- voltage that may be sufficient to constitute a risk of shock.



This symbol, wherever it appears, alerts you to important operating and maintenance instructions in the accompanying literature. Please read the manual.

1. Read these instructions.
2. Keep these instructions.
3. Heed all warnings.
4. Follow all instructions.
5. Do not use this apparatus near water.
6. Clean only with dry cloth.
7. Do not block any ventilation openings. Install in accordance with the manufacturer's instructions.
8. Do not install near any heat sources such as radiators, heat registers, stoves, or other apparatus (including amplifiers) that produce heat.
9. Do not defeat the safety purpose of the polarized or grounding-type plug. A polarized plug has two blades with one wider than the other. A grounding type plug has two blades and a third grounding prong. The wide blade or the third prong are provided for your safety. If the provided plug does not fit into your outlet, consult an electrician for replacement of the obsolete outlet.
10. Protect the power cord from being walked on or pinched particularly at plugs, convenience receptacles, and the point where they exit from the apparatus.
11. Only use attachments/accessories specified by the manufacturer.
12. Use only with the cart, stand, tripod, bracket, or table specified by the manufacturer, or sold with the apparatus. When a cart is used, use caution when moving the cart/apparatus combination to avoid injury from tip-over.
13. Unplug this apparatus during lightning storms or when unused for long periods of time.



WARNING:
TO REDUCE THE RISK OF FIRE OR ELECTRIC SHOCK, DO NOT EXPOSE THIS APPARATUS TO RAIN OR MOISTURE.

CAUTION:
TO REDUCE THE RISK OF ELECTRIC SHOCK, DO NOT REMOVE COVER. NO USER SERVICEABLE PARTS INSIDE. REFER SERVICING TO QUALIFIED SERVICE PERSONNEL.

14. Refer all servicing to qualified service personnel. Servicing is required when the apparatus has been damaged in any way, such as power-supply cord or plug is damaged, liquid has been spilled or objects have fallen into the apparatus, the apparatus has been exposed to rain or moisture, does not operate normally, or has been dropped.
15. **Damage Requiring Service**
Unplug the apparatus from the wall outlet and refer servicing to qualified service personnel under the following conditions:
 - A. When the power-supply cord or plug is damaged,
 - B. If liquid has been spilled, or objects have fallen into the apparatus,
 - C. If the apparatus has been exposed to rain or water,
 - D. If the apparatus does not operate normally by following the operating instructions. Adjust only those controls that are covered by the operating instructions as an improper adjustment of other controls may result in damage and will often require extensive work by a qualified technician to restore the apparatus to its normal operation,
 - E. If the apparatus has been dropped or damaged in any way, and
 - F. When the apparatus exhibits a distinct change in performance, this indicates a need for service.
16. **Object and Liquid Entry**
Never push objects of any kind into the apparatus through openings as they may touch dangerous voltage points or short-out parts that could result in a fire or electric shock.
17. If you install the apparatus in a built-in installation, such as a bookcase or rack, ensure that there is adequate ventilation.

Remarques importantes pour votre sécurité



L'éclair fléché dans un triangle équilatéral veut attirer l'attention de l'utilisateur sur le risque d'électrocution que présentent certains circuits internes non isolés.



Le point d'exclamation dans un triangle équilatéral veut attirer l'attention de l'utilisateur sur l'importance de certaines instructions concernant l'entretien et l'utilisation du produit.

1. Lisez attentivement ces instructions.
2. Veuillez les conserver pour vous y référer.
3. Tenez compte de tous les avertissements.
4. Suivez chaque instruction.
5. N'utilisez pas cet appareil près de l'eau.
6. Essuyez le boîtier avec un chiffon sec uniquement.
7. Ne bloquez pas les orifices d'aération et installez cet appareil selon les instructions du fabricant.
8. Ne l'installez pas près des sources de chaleur tels les calorifères, plinthes et radiateurs électriques, bouches de chauffage, poêles, ou tout autre appareil générant de la chaleur, comme les amplificateurs.
9. N'essayez pas de circonvenir les dispositifs de sécurité que représentent une fiche polarisée ou une fiche avec mise à la terre. Pour référence, une fiche polarisée possède deux lames dont l'une est plus large que l'autre, tandis qu'une fiche avec mise à la terre possède deux lames identiques et une broche de mise à la terre. La lame la plus large ou la broche assurent votre sécurité. Si la fiche de l'appareil ne peut être insérée dans la prise murale, demandez à un électricien de remplacer la prise désuète.
10. Protégez le cordon d'alimentation pour qu'on ne puisse pas marcher dessus ou le plier de façon excessive (particulièrement près des fiches, des cache-câbles et à la sortie de l'appareil).
11. N'utilisez que des fixations et accessoires préconisés par le fabricant.
12. N'utilisez l'appareil qu'avec un chariot, support ou trépied, une fixation ou une table approuvé(e) par le fabricant ou vendu(e) avec l'appareil. Tout chariot contenant l'appareil doit toujours être déplacé avec précaution afin d'éviter qu'il ne se renverse et blesse quelqu'un.



ATTENTION :

AFIN DE RÉDUIRE LES RISQUES DE DÉCHARGE ÉLECTRIQUE ET D'INCENDIE, N'EXPOSEZ PAS CET APPAREIL À L'HUMIDITÉ OU À LA PLUIE.

DANGER:

POUR ÉVITER TOUT DANGER DE DÉCHARGE ÉLECTRIQUE, N'OUVREZ PAS LE BOÎTIER OU LE PANNEAU ARRIÈRE DE L'APPAREIL. NE CONFIEZ L'ENTRETIEN ET LES RÉPARATIONS QU'À UN TECHNICIEN QUALIFIÉ.

13. Débranchez l'appareil durant un orage ou s'il reste inutilisé longtemps.
14. Veuillez faire appel à un technicien qualifié pour l'entretien et les réparations. Une réparation est indispensable si l'appareil a été endommagé d'une façon ou d'une autre : cordon d'alimentation ou fiche endommagée, petits objets ou liquide renversé dans l'appareil, exposition à la pluie ou à une humidité excessive, chute de l'appareil, ou si son fonctionnement est anormal.
15. **Dommages nécessitant une réparation**
Débranchez l'appareil et confiez-le à un technicien qualifié lorsque:
 - A. Le cordon d'alimentation ou sa fiche sont endommagés.
 - B. Du liquide a été déversé ou des objets sont tombés à l'intérieur de l'appareil.
 - C. L'appareil a été exposé à la pluie.
 - D. L'appareil ne semble pas fonctionner normalement lorsque vous l'utilisez suivant les instructions. Ne modifiez que les réglages autorisés dans le manuel, car le mauvais réglage d'autres commandes pourrait endommager l'appareil, nécessitant une longue et coûteuse remise en état par un technicien qualifié.
 - E. L'appareil a été échappé ou subi d'autres dommages.
 - F. Lorsque ses performances semblent soudainement détériorées.
16. **Présence de corps étrangers ou de liquide.**
N'insérez aucun objet à l'intérieur de l'appareil, car ils pourraient faire contact avec un point de tension dangereux ou provoquer un court-circuit avec les risques d'électrocution ou d'incendie qui en découlent.
17. Si vous devez encastrer cet appareil dans un meuble, une bibliothèque ou toute autre installation permanente, assurez-en la ventilation adéquate.

Front Panel



The design includes two power supplies configured in a “fail over” fashion for installed sound systems used in live sound, theater and broadcast applications. If one supply fails, the other immediately replaces it to continue operation without interruption.

The front panel includes a rocker type power switch and two LEDs that indicate the status of the power supplies. The LEDs will glow blue in normal operation, and blink red when a supply is inoperative.

Rear Panel

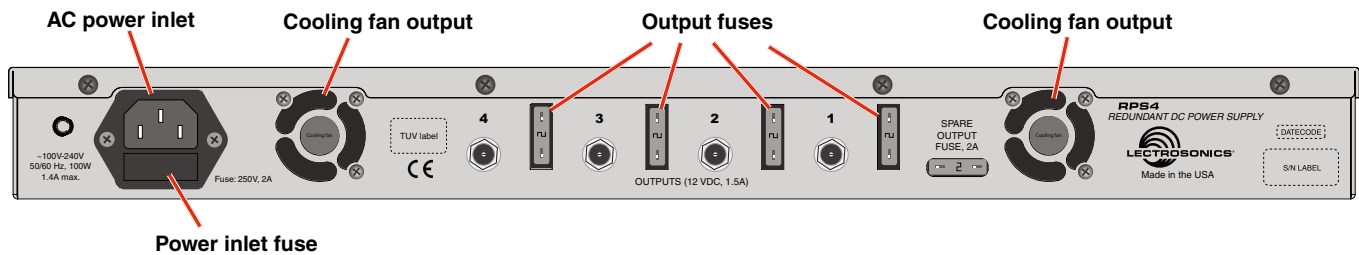

Operating Instructions

Power Switches

Turn the front panel power switch OFF before connecting a power cord, or connecting cables to the output jacks. It is also good practice to leave the power turned OFF on any device being connected to the RPS4 while connecting power cables.

The RPS4 can be powered from external mains power sources from 100 to 240VAC.

Front Panel Status LEDs

Two blue LEDs on the front panel indicate the state of the internal power supplies. Indications are as follows:

Normal operation	Both LEDs steady blue
Supply inoperative	Related LED blinks red

AC Inlet Fuse (Lectrosonics P/N 22124)

To replace the AC power inlet fuse, disconnect the AC power cord, and use a small tool (screwdriver) to release the tab and remove the fuse carriage.

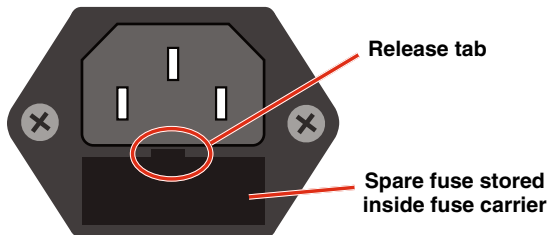

Output Fuses (Lectrosonics P/N 22119)

To replace an output fuse, pull it straight out of the jack on the rear panel. Square nose pliers may be needed for removal.

Use only the same type and value fuse for replacement.

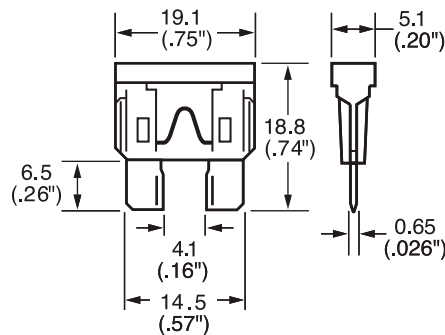

Output fuse

Accessories

AC Supply Cords

Lectrosonics P/N 21499 - NEMA 5-15 plug to IEC 60320 C13 connector; 6 ft. length; North America

Lectrosonics P/N 21642 - CEE 7/7 plug to IEC 60320 C13 connector; 6 ft. length; Continental Europe

Output Cables

Lectrosonics P/N 21841 - 32 inch "lamp cord" type cable assembly; straight locking connector on both ends; normally used to power Lectrosonics products (availability may be limited)



Lectrosonics P/N PSLZR Dual 12 - LZR style plug to LZR style plug. 12 in. long.



Lectrosonics P/N PSLZR Dual 18- LZR style plug to LZR style plug. 18 in. long.



Typical Dimensions of Power Connector

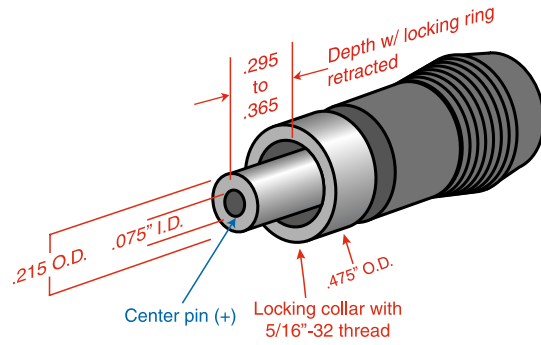

Compatible Switchcraft Connectors

Switchcraft S760K connector; black handle

Switchcraft S765K connector; red handle

Replacement Fuses

Lectrosonics P/N 22124 - AC inlet fuse; 2A, 250V; 5 x 20mm cylindrical; glass or ceramic body.

Lectrosonics P/N 22119 - Output fuse; 2A, 32V; automotive blade type; Littelfuse 257 or ATOF 287 Series; grey handle color

Specifications

Input voltage range:	100 to 240 VAC; 1.4A max.; 50/60 Hz
Overall power consumption:	100 W Max.
Outputs (four):	12 VDC; 1.5A; 18 watts
Output fuses:	Individual 2A automotive blade type
Temperature range:	-20C to +50C
Output DC ripple:	< 20 mV
Height:	1.75 in.; 44.5 mm
Width:	<ul style="list-style-type: none"> • Faceplate: 19 in.; 48.3 cm • Housing: 17.4 in.; 44.2 cm
Depth:	9.1 in.; 23.1 cm
Weight:	4.68 lbs.; 2.13 kg



P.O. Box 15900 - Rio Rancho, NM - 87174 - USA
 Phone: (800)821-1121 or (505)892-4501 - Fax: (505)892-6243
 web: www.lectrosonics.com - email: sales@lectrosonics.com

EU Declaration of Conformity

LECTROSONICS, INC.
581 Laser Road
Rio Rancho, NM 87124 USA

Declares under our sole responsibility that the following product:

Model: RPS4

Redundant DC Power Supply

is in conformity with the provisions of the following EC directive(s) (including applicable amendments) and are designed and manufactured in accordance with the harmonized standards:

Document	Description	Date/Version
	Electromagnetic Compatibility	
EN 5503	Electromagnetic Compatibility of Multimedia Equipment	2012
	Safety and Health	
EN 60950-1	Information technology equipment – Safety	2015
RL 2011/65/EU	RoHS Directive 2011/65/EU: Restriction of the use of certain hazardous substances (RoHS Recast)	2011

Testing was performed by notified body TUV Rheinland of North America, Inc.

Rio Rancho, NM USA, 06 Sep 2017

Robert Cummings
 V.P. Engineering
 Lectrosonics, Inc.

Note: This equipment has been tested and found to comply with the limits for a Class B digital device, pursuant to part 15 of the FCC Rules. These limits are designed to provide reasonable protection against harmful interference in a residential installation. This equipment generates, uses and can radiate radio frequency energy and, if not installed and used in accordance with the instructions, may cause harmful interference to radio communications. However, there is no guarantee that interference will not occur in a particular installation. If this equipment does not cause harmful interference to radio or television reception, which can be determined by turning the equipment off and on, the user is encouraged to try to correct the interference by one or more of the following measures:

- Reorient or relocate the receiving antenna.
- Increase the separation between the equipment and receiver.
- Connect the equipment into an outlet on a circuit different from that to which the receiver is connected.
- Consult the dealer or an experienced radio/TV technician for help.

Service and Repair

If your system malfunctions, you should attempt to correct or isolate the trouble before concluding that the equipment needs repair. Make sure you have followed the setup procedure and operating instructions. Check the interconnecting cables.

We strongly recommend that you **do not** try to repair the equipment yourself and **do not** have the local repair shop attempt anything other than the simplest repair. If the repair is more complicated than a broken wire or loose connection, send the unit to the factory for repair and service. Don't attempt to adjust any controls inside the units. Once set at the factory, the various controls and trimmers do not drift with age or vibration and never require readjustment. **There are no adjustments inside that will make a malfunctioning unit start working.**

LECTROSONICS' Service Department is equipped and staffed to quickly repair your equipment. In warranty repairs are made at no charge in accordance with the terms of the warranty. Out-of-warranty repairs are charged at a modest flat rate plus parts and shipping. Since it takes almost as much time and effort to determine what is wrong as it does to make the repair, there is a charge for an exact quotation. We will be happy to quote approximate charges by phone for out-of-warranty repairs.

Returning Units for Repair

For timely service, please follow the steps below:

- A. DO NOT return equipment to the factory for repair without first contacting us by e-mail or by phone. We need to know the nature of the problem, the model number and the serial number of the equipment. We also need a phone number where you can be reached 8 A.M. to 4 P.M. (U.S. Mountain Standard Time).
- B. After receiving your request, we will issue you a return authorization number (R.A.). This number will help speed your repair through our receiving and repair departments. The return authorization number must be clearly shown on the **outside** of the shipping container.
- C. Pack the equipment carefully and ship to us, shipping costs prepaid. If necessary, we can provide you with the proper packing materials. UPS or FEDEX is usually the best way to ship the units. Heavy units should be "double-boxed" for safe transport.
- D. We also strongly recommend that you insure the equipment, since we cannot be responsible for loss of or damage to equipment that you ship. Of course, we insure the equipment when we ship it back to you.

Lectrosonics USA:

Mailing address:

Lectrosonics, Inc.
PO Box 15900
Rio Rancho, NM 87174
USA

Web:

www.lectrosonics.com

Shipping address:

Lectrosonics, Inc.
561 Laser Rd., Suite 102
Rio Rancho, NM 87124
USA

E-mail:

service.repair@lectrosonics.com
sales@lectrosonics.com

Telephone:

+1 (505) 892-4501
(800) 821-1121 Toll-free US and Canada
Fax +1 (505) 892-6243

Lectrosonics Canada:

Mailing Address:

720 Spadina Avenue,
Suite 600
Toronto, Ontario M5S 2T9

Telephone:

+1 (416) 596-2202
(877) 753-2876 Toll-free Canada
(877) 7LECTRO
Fax (416) 596-6648

E-mail:

Sales: colinb@lectrosonics.com
Service: joeb@lectrosonics.com

LIMITED ONE YEAR WARRANTY

The equipment is warranted for one year from date of purchase against defects in materials or workmanship provided it was purchased from an authorized dealer. This warranty does not cover equipment which has been abused or damaged by careless handling or shipping. This warranty does not apply to used or demonstrator equipment.

Should any defect develop, Lectrosonics, Inc. will, at our option, repair or replace any defective parts without charge for either parts or labor. If Lectrosonics, Inc. cannot correct the defect in your equipment, it will be replaced at no charge with a similar new item. Lectrosonics, Inc. will pay for the cost of returning your equipment to you.

This warranty applies only to items returned to Lectrosonics, Inc. or an authorized dealer, shipping costs prepaid, within one year from the date of purchase.

This Limited Warranty is governed by the laws of the State of New Mexico. It states the entire liability of Lectrosonics Inc. and the entire remedy of the purchaser for any breach of warranty as outlined above. **NEITHER LECTROSONICS, INC. NOR ANYONE INVOLVED IN THE PRODUCTION OR DELIVERY OF THE EQUIPMENT SHALL BE LIABLE FOR ANY INDIRECT, SPECIAL, PUNITIVE, CONSEQUENTIAL, OR INCIDENTAL DAMAGES ARISING OUT OF THE USE OR INABILITY TO USE THIS EQUIPMENT EVEN IF LECTROSONICS, INC. HAS BEEN ADVISED OF THE POSSIBILITY OF SUCH DAMAGES. IN NO EVENT SHALL THE LIABILITY OF LECTROSONICS, INC. EXCEED THE PURCHASE PRICE OF ANY DEFECTIVE EQUIPMENT.**

This warranty gives you specific legal rights. You may have additional legal rights which vary from state to state.

