

**DHu**

**Digital Handheld Transmitter**

Follow  
Us On:



# Table of Contents

<b>General Technical Description</b> .....	<b>3</b>
<b>Microphone Capsules:</b> .....	<b>4</b>
<b>Mechanical Assembly</b> .....	<b>4</b>
<b>Battery Installation</b> .....	<b>5</b>
<b>Control Panel</b> .....	<b>5</b>
<b>Setup and Adjustments</b> .....	<b>6</b>
Powering On .....	6
Powering Off .....	6
Standby Mode .....	6
Power Menu .....	6
Navigating Menus and Screens .....	7
<b>Menu Map</b> .....	<b>7</b>
<b>Input Gain Adjustment</b> .....	<b>10</b>
<b>Programmable Switch Functions</b> .....	<b>10</b>
<b>Parts and Accessories</b> .....	<b>12</b>
<b>Mic Capsule Adjustments</b> .....	<b>13</b>
(EXPERT LEVEL ADJUSTMENT) .....	13
<b>Specifications</b> .....	<b>14</b>
<b>Wireless Designer Software</b> .....	<b>14</b>
<b>Firmware Update Instructions</b> .....	<b>14</b>
<b>Troubleshooting</b> .....	<b>15</b>
<b>Service and Repair</b> .....	<b>17</b>
Returning Units for Repair .....	17

# General Technical Description

## Introduction

The transmitter benefits from a fourth generation design with specially developed, high efficiency digital circuitry for extended operating time on two AA batteries. The transmitter can tune across the UHF television band from 470.100 to 607.950 MHz, with a selectable output power of 25 or 50 mW. The pure digital architecture enables AES 256-CTR encryption for applications that require high level security.

## Input Gain Range and Limiter

45 dB range of input gain adjustment allows gain settings to accurately match the user's voice and the varying sensitivity of different microphone capsules. A DSP-controlled analog audio limiter is employed before the A-D converter. The limiter has a range of more than 30 dB for excellent overload protection. A dual release envelope makes the limiter acoustically transparent while maintaining low distortion. It can be thought of as two limiters in series, a fast attack and release limiter followed by a slow attack and release limiter. The limiter recovers quickly from brief transients, with no audible side effects, and also recovers slowly from sustained high levels to keep audio distortion low while preserving short term dynamics.

## Frequency Selection

Operating frequency is normally selected using a receiver or analyzer to assess signals in the local environment to avoid interference. Once an interference-free frequency is identified, the transmitter frequency is set to match the receiver.

The LCD on the transmitter displays frequency in MHz and with a two character hex code that is used on most Lectrosonics receivers.

## Antenna

A unique helical antenna allows the transmitter to be held in any position, since the user's hands have little or no effect on the RF output power.

## Microphone Capsules

The transmitter is available from Lectrosonics with the HHC and HHVMC cardioid condenser capsules. Capsules from several other manufacturers are also available for use with the HH: those with a 1.25" x 28 thread pitch and three contact rings. Condenser or dynamic microphone capsules can be used to suit the user's preference or the application.

## Encryption

When transmitting audio, there are situations where privacy is essential, such as during professional sporting events, in court rooms or private meetings. For instances where your audio transmission needs to be kept secure, without sacrificing audio quality, Lectrosonics introduces Encryption Keys. Truly entropic encryption keys are first created by a Lectrosonics receiver, such as the DSQD Receiver. The key is then synced with the DHu via the IR port. The audio will be encrypted and can only be listened to if both DHu and receiver have the matching encryption key. If you are trying to transmit an audio signal and keys do not match, all that will be heard is silence or white noise.

## IR (infrared) Sync

An IR Sync Port is used for quick setup with receivers that offer this feature. Settings for frequency, step size and compatibility mode are transferred from receiver to transmitter via the IR ports.

## Side Button Functions

A programmable switch on the side of the housing can be configured as a mute/cough switch, a power switch or be disabled.

## USB Port for Key Transfer and Firmware Updates

The encryption key is generated in the receiver, then transferred to the transmitter via a USB port using a cable. This requires that the user be in direct contact with both units, which increases the security level.

Firmware updates are enabled by simply downloading a file and utility program from the Lectrosonics web site, connecting the transmitter to a computer via the USB port and running the program.

## Mechanical Assembly



A mic capsule is threaded onto the body of the transmitter in the direction shown. Do not overtighten it.

The threaded interface is a 1.25" diameter opening with 28 threads per inch and three contact rings



The lower housing opens by rotating it in the direction shown. After the threads are disengaged, pull the housing downward until it engages the detent that holds it open.

## Microphone Capsules:

Lectrosonics offers two types of capsules. The HHC is the standard capsule and the HHVMC is the Variable Mic Capsule which includes adjustments for Bass, Midrange and Treble.



*HHC Lectrosonics cardioid electret*



*HHVMC Lectrosonics cardioid electret with VariMic preamp*

Along with these two models from Lectrosonics, a variety of different capsules with a common thread and electrical interface are available from the major microphone manufacturers.

A list of compatible capsules is on the website at [www.lectrosonics.com](http://www.lectrosonics.com) listed the DHu product page.

Do not touch the contacts between the mic capsule and transmitter body. When necessary, the contacts can be cleaned with a cotton swab and alcohol.



## Capsule Installation

Capsules are attached with a right-hand thread.

To remove the windscreen from the mic capsule, line up the blue wrench (included with the capsule head) with the flat notches on the lower threaded area of the mic capsule.

Align flats on the wrench with flats on the capsule.



\*All product names are trademarks of their respective owners, which are in no way affiliated with Lectrosonics.

## Battery Installation

To insert batteries, close the eject lever and insert the upper contacts first (closest to the mic capsule). Polarity is marked on the label in the bottom of the battery compartment.



The contacts are very tight to prevent the batteries from “rattling” as the transmitter is being handled. Pull the eject lever outward to remove the batteries. The battery tips will move outward, making them easier to grasp.

**Pull eject lever outward to release batteries from contacts**



## Control Panel

Six membrane switches on the control panel are used to set up the transmitter by navigating the menus on the LCD and selecting the desired values.



# Setup and Adjustments

## Powering On

Press and hold the Power Button until a status bar on the LCD is completed. The status bar will appear on the LCD, followed by a display of the model, firmware version, frequency band and compatibility mode.

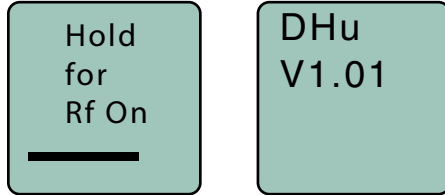

When you release the button, the unit will be operational with the RF output turned ON and the Main Window displayed.

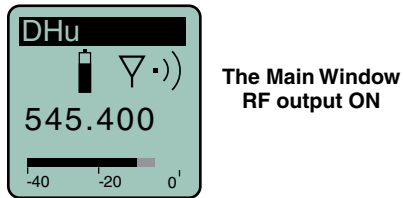

If you release the button before the countdown is complete, the unit will turn on in the Standby mode with the RF output turned OFF and the antenna icon will blink.

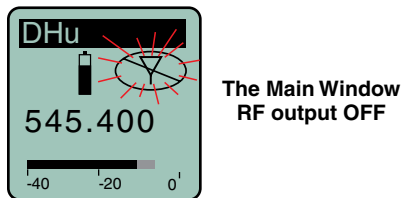

## Powering Off

Press and hold the Power Button (or the side button if it is configured for turning the power on and off) while the status bar on the LCD is completed. The power will then be turned off. This can be done from any menu or screen.

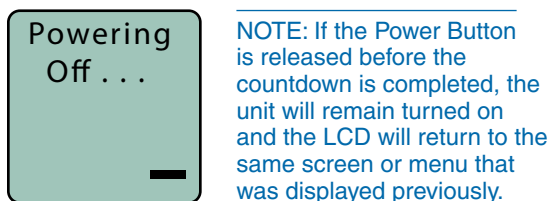

## Standby Mode

A brief push of the keypad Power Button turns the unit on and places it into a “standby” mode (not transmitting). Press the button and release before the status bar completes. This allows the transmitter to be set up without the risk of creating interference for other wireless systems that are operating in the vicinity.

A notice will appear briefly confirming that the RF output of the transmitter is turned off, followed by the Main Window. The antenna symbol will blink as a reminder that the RF output is turned off.

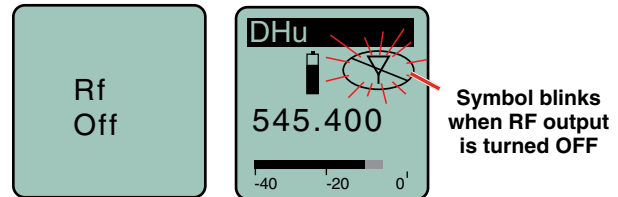

## Power Menu

When the transmitter is turned on, a brief push of the Power Button on the keypad will reveal a menu allowing you to choose between **Resume**, **Pwr Off**, **Rf On?**, **Backlit** and **About**.

Use the **UP/DOWN** buttons to select one of the menu items, then press the **MENU/SEL** button to confirm this action.

- **Resume:** Continue operating in the same condition as before.
- **Pwr Off:** Turns off the transmitter.
- **Rf On?:** Begin transmitting the RF signal, enters another screen prompting a **Yes** or **No** answer.
- **Backlit:** The LCD includes a backlight that illuminates the display for easier viewing. It is set to come on when any button on the control panel is pressed, then stay on for 5 seconds, 30 seconds or stay on all the time.
- **About:** Displays the model, firmware version, frequency block and compatibility mode.

The unit can also be turned off from any menu or screen on the LCD by holding the power button in while the status bar on the LCD is completed.

## Battery Condition

An icon on the Main Window indicates the approximate remaining power of the batteries. This battery gauge is most accurate with the typical voltage drop across the life of alkaline batteries.

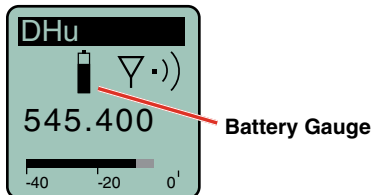

Rechargeable batteries give little or no warning when nearing depletion. If you use rechargeable batteries in the transmitter, we recommend trying fully charged batteries first, noting the length of time that the batteries will run the unit, and in the future using somewhat less than that time to determine when the battery needs to be replaced. The Venue and other receivers from Lectrosonics offer a timer function to assist in this process.

## Navigating Menus and Screens

The *Main Window* displays the following information:

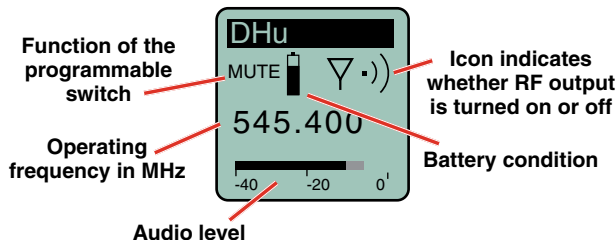

- 1) Press the **MENU/SEL** button to enter the setup menu. Use the **UP/DOWN** buttons to highlight the menu item.
- 2) Press the **MENU/SEL** button to enter the setup screen for that item. Use the **UP/DOWN** buttons to select the desired value or mode.

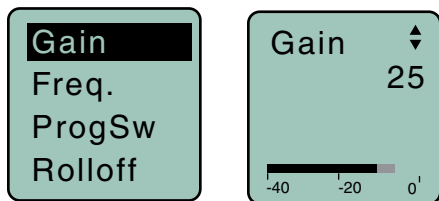

- 3) Press the **MENU/SEL** button to save this setting and return to the previous screen.
- 4) Press the **BACK** button to return to the Main Window.

## Menu Map

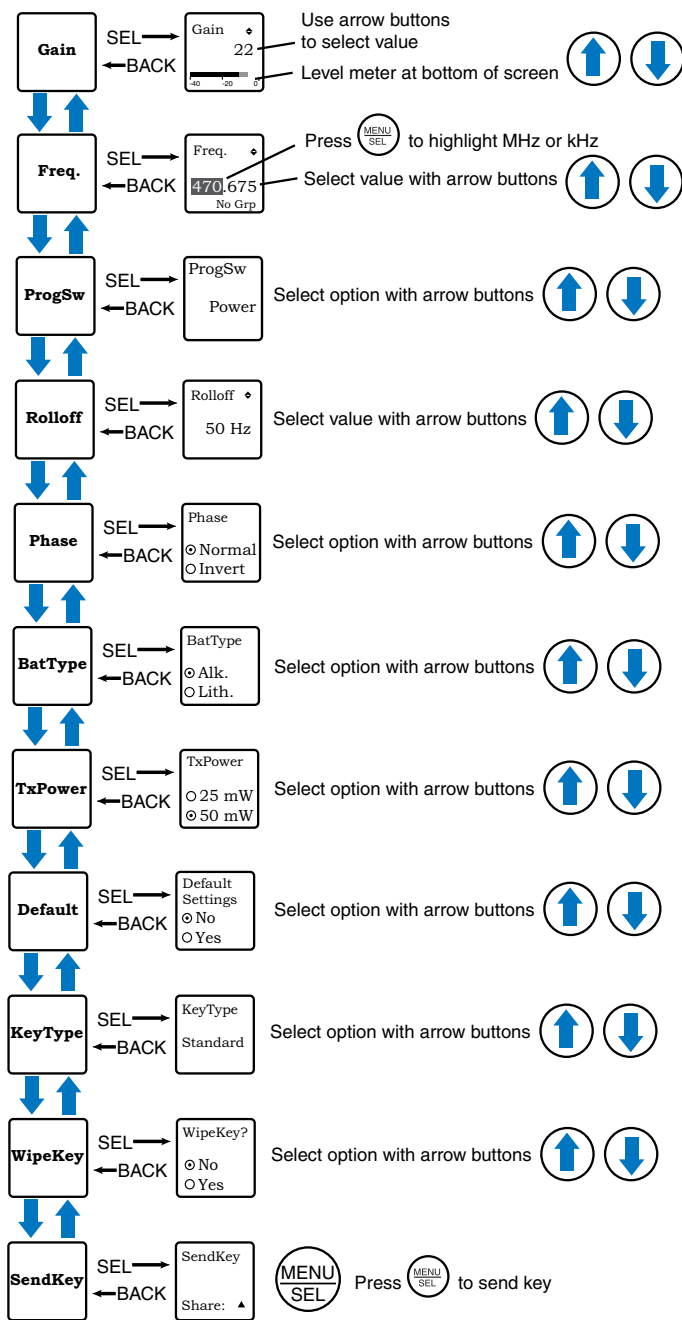

### Gain

This setting is very important since it can have a significant effect on the signal to noise ratio the system will deliver. The gain adjustment can even affect the operating range of the wireless system. Gain must be set according to the individual voice, the mic capsule in use and the handling technique of the user. LEDs in the control panel facilitate accurate gain adjustment.

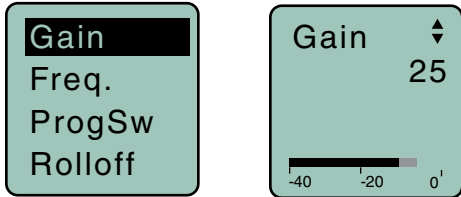

**IMPORTANT:** See the section *Input Gain Adjustment* on page 9 for details.

### Freq.

The operating frequency is normally determined using the scanning function in the receiver or with coordination software. The frequency is shown on the transmitter LCD display in MHz and with a hexadecimal code that is used on most Lectrosomics receivers.

Frequency groups are also able to be received via IR (Infrared) port sync. The group options are set by the receiver, and will show at the bottom of the screen as No Grp, Grp x, Grp w, Grp v, or Grp u.

Use the **MENU/SEL** button to toggle between options and **UP** and **DOWN** arrows to adjust.

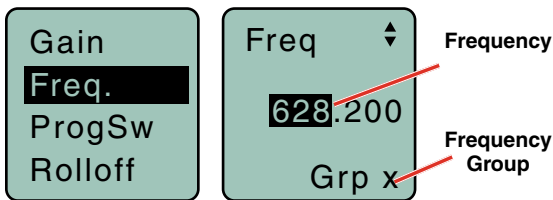

### ProgSw

The Programmable Switch on the housing can be set to provide several functions, or it can be bypassed.

**NOTE:** See section on *Programmable Switch Functions*.

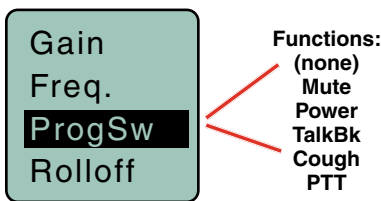

### Rolloff

A low frequency roll-off filter can be set for a -3dB point at 25, 35, 50, 70, 100, 120 or 150 Hz. Roll-off slopes are 12.2 dB/octave at 35 Hz and 10.1 dB/octave at 70 Hz through 125 Hz.

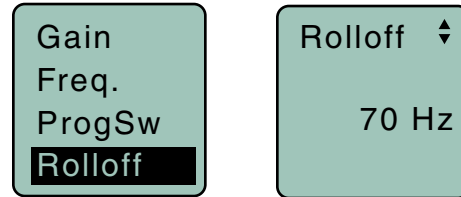

The roll-off frequency is normally adjusted by ear to suit personal preferences.

### Phase

The phase (polarity) of the audio can be inverted to match other microphone capsules as needed.

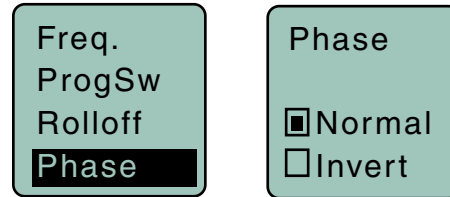

### BatType

Selects the type of batteries being used; alkaline or lithium.

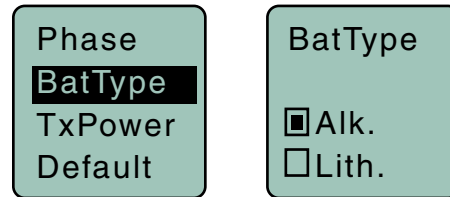

### TxPower

Output power can be set to 100 mW to extend operating range (which can also suppress noise and drop-outs to some extent) or set to 50 mW to slightly extend the operating life of the batteries.

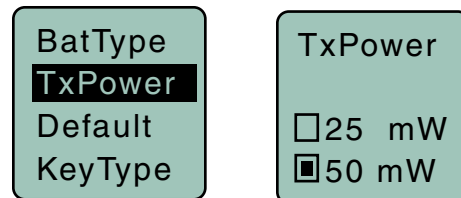



### Default

The default setting simple returns the transmitter back to the factory settings and any of the menu items can be readjusted from that default point.

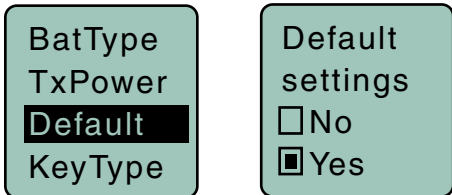

### KeyType

The DHu receives an encryption via the IR port from a key generating receiver. Begin by selecting a key type in the receiver and generating a new key (key type is labeled KEY POLICY in the DSQD receiver). Set the matching KEY TYPE in the DHu and transfer the key from the receiver (SYNC KEY) to the DHu via the IR ports. A confirmation message will display on the receiver display if the transfer is successful. The transmitted audio will then be encrypted and can only be listened to if the receiver has the matching encryption key.

The DHu has three options for encryption keys:

- **Standard:** This is the highest level of security. The encryption keys are unique to the receiver and there are only 256 keys available to be transferred to a transmitter. The receiver tracks the number of keys generated and the number of times each key is transferred.
- **Shared:** There are an unlimited number of shared keys available. Once generated by a receiver and transferred to the DHu, the encryption key is available to be shared (synced) by the DHu with other transmitters/receivers via the IR port. When a transmitter is set to this key type, a menu item named SEND KEY is available to transfer the key to another device.
- **Universal:** This is the most convenient encryption option available. All encryption-capable Lectrosonics transmitters and receivers contain the Universal Key. The key does not have to be generated by a receiver. Simply set the DHu and a Lectrosonics receiver to Universal, and the encryption is in place. This allows for convenient encryption amongst multiple transmitters and receivers, but not as secure as creating a unique key.

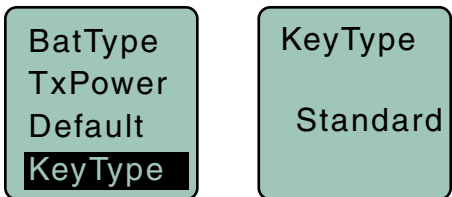

### WipeKey

This menu item is only available if Key Type is set to Standard or Shared. Select Yes to wipe the current key and enable the DHu to receive a new key.

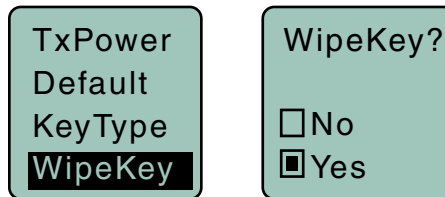

### SendKey

This menu item is only available if Key Type is set to Shared. Press **MENU/SEL** to sync the Encryption key to another transmitter or receiver via the IR port.

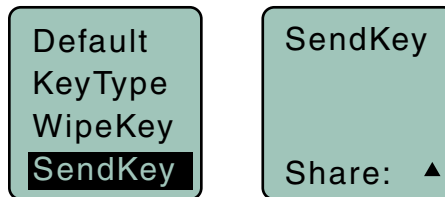

# Input Gain Adjustment

While the digital system has an excellent signal to noise ratio over a wide range of gain adjustment, it is still good practice to set the gain close to full modulation. The two bicolor Modulation LEDs (located at the bottom of the control panel) are used to accurately adjust the gain. They are upside/down from the keypad for viewing with the capsule close to your mouth.

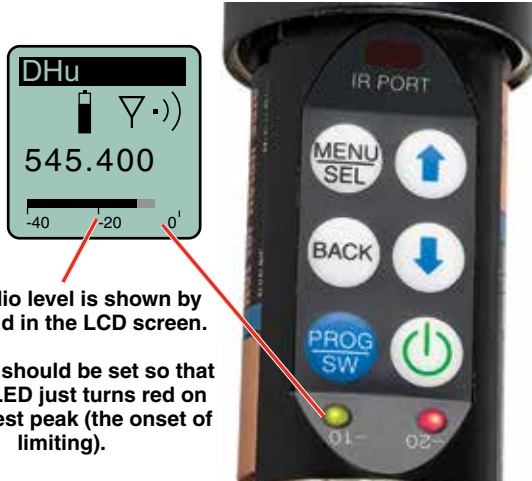

The audio level is shown by LEDs and in the LCD screen.

The gain should be set so that the -20 LED just turns red on the loudest peak (the onset of limiting).

The LEDs will glow either red or green to indicate modulation levels as shown in the following table.

Signal Level	-20 LED	-10 LED
Less than -20 dB	● Off	● Off
-20 dB to -10 dB	● Green	● Off
-10 dB to +0 dB	● Green	● Green
+0 dB to +10 dB	● Red	● Green
Greater than +10 dB	● Red	● Red

It is best to go through the following procedure with the transmitter in the “standby” mode so that no audio will enter the sound system, which could cause feedback.

- 1) With fresh batteries in the transmitter, power the unit on into “standby” mode (RF output off)
- 2) Press the **MENU/SEL** button once to enter the setup menu. Use the **UP/DOWN** buttons to select **Gain**. Press the **MENU/SEL** button again to enter the setup screen.
- 3) Hold the microphone the way it will be used in actual operation.
- 4) Speak or sing at the same voice level that will actually be used during the program, while observing the modulation LEDs. Use the **UP/DOWN** buttons to adjust the gain until the **-20 dB** LED starts to flicker red and the **-10 dB** glows green.
- 5) Once the audio gain has been set, the signal can be sent through the sound system for overall level adjustments, monitor settings, etc. To do this, the unit must be set to transmit (see **Powering On and Off**, and the **Standby Mode**).

# Programmable Switch Functions

A special button on the outside of the housing can be configured to provide several different functions, or to be inoperative by selecting **(none)**.



The **ProgSw** button on the keypad opens a setup screen to select the programmable switch function. Enter this setup screen and then use the **UP/DOWN** arrows to select the desired function and press the **MENU/SEL** button to return to the Main Window.



The **ProgSw** menu provides a scrollable list of the available functions. Use the **UP/DOWN** arrows to highlight the desired function and press **BACK** or **MENU/SEL** to select it and return to the main menu.

ProgSw

Power

**Power** turns the power on and off. Hold the button on the housing in until the countdown sequence from 3 to 1 is completed. The power will then be turned off.

**NOTE:** When the button on the housing is set to **Power**, it will turn on the transmitter in the operating mode with the RF output on. Use the power button on the keypad to turn on the transmitter in the Standby Mode.

ProgSw

Cough

**Cough** is a momentary mute switch. Audio is muted while the button on the housing is held in.

ProgSw  
PTT

**Push To Talk** is a momentary talk switch. Audio is transmitted while the button on the housing is held (opposite of cough)

ProgSw  
Mute

**Mute** is a “push on/push” off function that toggles on and off each time the button on the housing is pressed. The mute function defeats the audio in the transmitter, so it works in all compatibility modes and with all receivers.

ProgSw  
(none)

**(none)** disables the button on the housing.

ProgSw  
TalkBk

**TalkBk** is a “push to talk” function that is active only while the button is pressed. The talkback function provides a communication channel when used with a receiver equipped with this function, such as a Venue Wideband receiver with firmware

Ver. 5.2 or higher. When pressed and held in, the side button re-directs the audio output to a different audio channel on the receiver. As soon as the switch is released, audio is returned to the program channel.

### Main Window Displays for Function

The function of the Programmable Switch is displayed in the LCD Main Window. In the None and Power functions, no indication is displayed. In the Mute and Cough functions, the word MUTE is displayed.

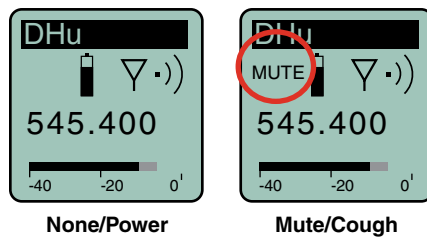

When the button on the housing is pressed, the function will be active and the LCD will display an indication for the Mute and Cough functions. The word MUTE will be shown in reverse video and the audio level bar at the bottom of the display will be replaced by a blinking word MUTE.

Reverse video

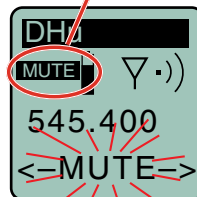

Mute active (MUTE blinks)

# Parts and Accessories

## #CCHH - Zippered Pouch

Padded zipper pouch for handheld transmitter



## #26872 Mic Capsule Wrench

Custom wrench for removing windscreen from mic capsule



## #13585 Mic Clip

Screw on mic clip for standard mic stands with 5/8"-27 thread



## HHXTND

Extender to for use with microphone flags commonly used in ENG for network or station ID to keep the flag from covering the side switch and LCD



## HH2SEN Adapter

Adapts Sennheiser G2, G3 and 2000 Series microphone capsule heads to the HH transmitter.

Transmitter interface



Capsule interface



## HHA Adapter by Ambient Recording



Adapts Neumann KK104 and KK105 and Sennheiser capsules for the 5000 Series wireless with Shure style threads to the DHu transmitter

**HHA is available from Ambient Recording dealers**  
**Visit: [www.ambient.de](http://www.ambient.de)**

# Mic Capsule Adjustments

## (EXPERT LEVEL ADJUSTMENT)

These adjustments significantly alter the gain and tonal quality of the microphone, and are to be used only in special circumstances.

*Caution: Always make the final decision about sound quality with the windscreen in place.*

Remove the windscreen using the supplied wrench.

Align flats on the wrench with flats on the capsule.

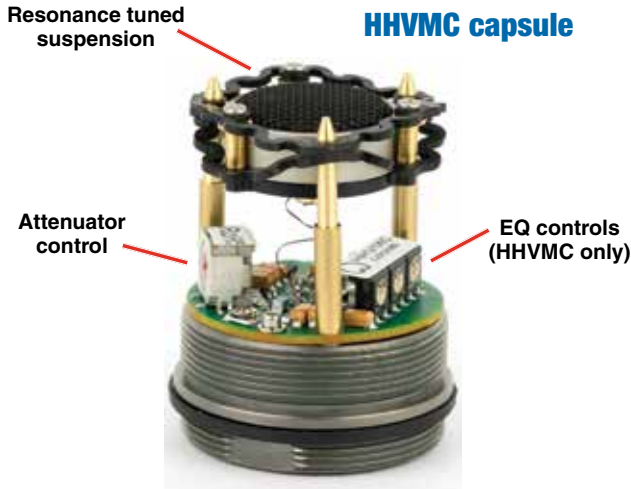

### LO/MID/HI (bass/mid/treble) - HHVMC only

The HHVMC head includes VariMic™ equalization adjustments to boost or cut the frequency response in LOW, MID and HIGH ranges. The LOW and HIGH controls will boost/cut by up to 8 dB while the MID control will boost/cut up to 6 dB.

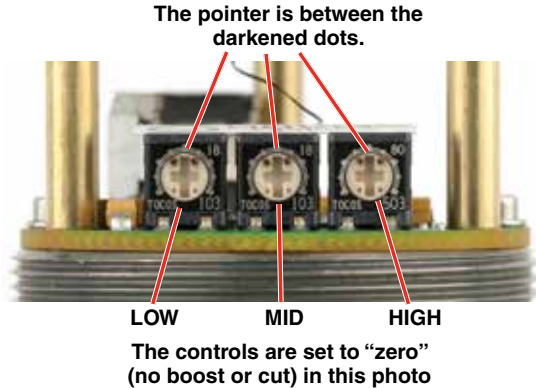

### Attenuator Adjustment

The HHC & HHVMC heads include an attenuator in the preamp circuitry to provide an additional 15 dB of headroom when needed for extremely loud voices.

The attenuator should **ONLY** be used **when the gain control in the menu is already turned all the way down** and the audio is still driving the preamp into significant limiting where both -20 and -10 dB LEDs often light up red or stay red during peaks in the audio.

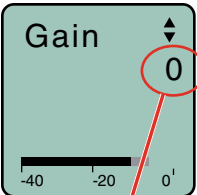

Gain set to minimum (0) on the LCD.



LEDs on control panel

The attenuator control is a 16-position switch that attenuates the audio in 1 dB steps. It is marked **0** through **F** where **F** is minimum attenuation and **0** is maximum attenuation. Rotating it clockwise increases the loudness, and counter clockwise decreases the loudness.

Attenuator switch set at F for normal operation.

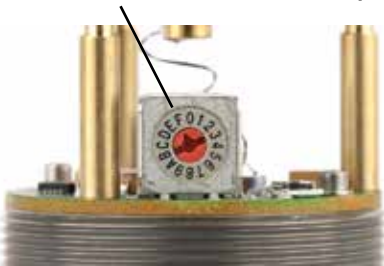

**Reset the switch to F for subsequent users**

These controls operate as standard tone controls in that a counterclockwise adjustment cuts the response in that band and a clockwise adjustment boosts the response.

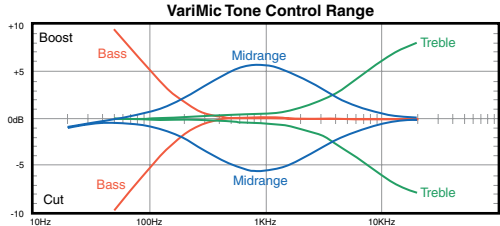

## Specifications

Frequency range:	470.100 - 607.950 MHz
Frequency selection steps:	Selectable; 100 kHz or 25 kHz
RF Power output:	Selectable; 25 or 50 mW
Frequency stability:	± 0.002%
Digital Modulation:	8 psk
Spurious radiation:	Compliant ETSI EN 300 422-1 v1.4.2
Operating temperature range:	-20° C to +50° C
Input compressor:	Dual envelope compressor, >30 dB range
Gain control range:	45 dB; semi-log menu-driven control; 1 dB steps
Modulation indicators:	Dual bicolor LEDs indicate modulation of -20, -10, 0 and +10 dB referenced to full modulation, LCD bar-graph indicator
Frequency response	40 Hz to 20 kHz (+/- 1dB)
Low frequency roll-off:	-3 dB @35, 50 and 70 Hz; selectable; 36 dB/octave
Controls:	
External:	Programmable mute/talkback button
Battery compartment:	Power, mute disable, menu/select, up/down, and back arrow buttons for menu selection and settings
Battery:	2x AA with polarity protection and battery ejector
Battery life:	At 50 mW: 5 hours (Duracell Quantum); battery status is transmitted to Lectrosonics receivers
Capsule Interface:	1.25" opening and 28 thread pitch Power available: 5V, 25 mA max Input impedance: 1000 Ohms
Weight:	12.1 oz. with batteries and HHC capsule
Dimensions:	9.5" long x 1.97" diameter at largest point

Emission Designator: 200KG1E

Specifications subject to change without notice.

## Wireless Designer Software

Download the Wireless Designer software installer from the web sites under the SUPPORT tab at:

<http://www.lectrosonics.com/US>

<http://www.lectrosonics.com/europe/>

Wireless Designer only needs to be installed the first time the software is used. Once the software is installed, updates are available by simply clicking on an item in the Help Menu.

**Note:** If Wireless Designer is already installed, you must uninstall it before attempting to install a new copy.

## Firmware Update Instructions

Firmware updates are made with a file downloaded from the web site and the DBu connected via USB.

The USB port on the transmitter requires a micro-B male plug on the connecting cable. The other end of the cable would normally be a USB A-Type male connector to fit the most common type of USB jack used on computers.

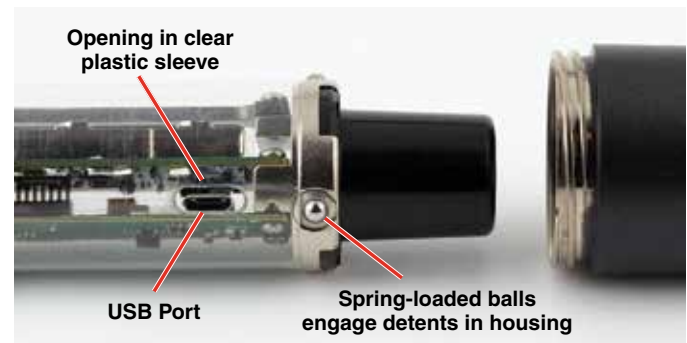

Refer to **Help** in Wireless Designer software for the procedure.

# Troubleshooting

## SYMPTOM

TRANSMITTER WILL NOT POWER ON

## POSSIBLE CAUSE

- 1) Batteries are inserted backwards.
- 2) Batteries are dead, or too low to be used.

MODULATION LEDs DO NOT LIGHT

- 1) Audio Gain set too low.
- 2) Mic capsule is damaged or malfunctioning. Try a different capsule or contact the factory for repair.

MODULATION LEDs INDICATE BUT NO SOUND

- 1) Talkback function is engaged (release the button on the housing). See p. 10.
- 2) Check receiver display for audio level indication
- 3) Receiver on wrong frequency or wrong band.
- 4) Receiver connected incorrectly to sound system.
- 5) Transmitter in standby mode.

RECEIVER RF INDICATOR OFF

- 1) Transmitter not turned on.
- 2) Transmitter is in "standby" (non-transmitting) mode. Check the LCD for the antenna/transmission icon status.
- 3) Batteries are dead or installed backwards.
- 4) Receiver antenna missing, defective or improperly positioned.
- 5) Transmitter and receiver not on the same frequency.
- 6) Operating range is too great.
- 7) Receiver antenna missing, incorrect frequency or disconnected.

NO SOUND BUT RECEIVER AUDIO LEVEL METER INDICATES SOUND

- 1) Receiver audio is muted. (Unmute receiver.)
- 2) Receiver audio output levels set too low.
- 3) Receiver audio output is disconnected or cable defective or mis-wired.
- 4) Sound system or recorder input level is turned down.

DISTORTED SOUND

- 1) Transmitter Audio Gain set too high. Speak or sing into the transmitter and check the Audio Level LEDs and/or Audio Level bar graph in the transmitter LCD and corresponding indicators on the receiver.
- 2) Receiver output level may be too high for the sound system or recorder input.
- 3) Excessive wind noise or "breath pops." Microphone may require an additional wind screen.
- 4) Mic capsule damaged or defective

HISS AND NOISE -- AUDIBLE DROPOUTS

- 1) Transmitter Audio Gain set too low. See page 9 for proper audio gain setting.
- 2) Receiver antenna missing, defective or obstructed.
- 3) Operating range too great.
- 4) Interference may be present. Turn transmitter off and observe the RF level indicator on the receiver. Change frequency if necessary.
- 5) With Lectrosonics HHC or HHVMC: return attenuator control back to default setting of "F" (see opposite page), then readjust audio gain per instructions on page 9.

EXCESSIVE FEEDBACK

- 1) Transmitter Audio Gain set too high. Check level adjustment, reduce receiver output level, or both.
- 2) Microphone too close to speaker system.
- 3) Move microphone closer to the user's mouth and lower the sound system volume.

**FCC Compliance:**

This device complies with FCC radiation exposure limits as set forth for an uncontrolled environment. This device should be installed and operated so that its antenna(s) are not co-located or operating in conjunction with any other antenna or transmitter.

**FCC Notice to the End User:**

The normal condition of using this device is to keep the hand at least 20mm away from the base of the microphone.

**ISED Notices:****Per RSS-210**

This device operates on a no-protection no-interference basis. Should the user seek to obtain protection from other radio services operating in the same TV bands, a radio licence is required. Please consult Industry Canada's document CPC-2-1-28, Optional Licensing for Low-Power Radio Apparatus in the TV Bands, for details.

Ce dispositif fonctionne selon un régime de non-brouillage et de non-protection. Si l'utilisateur devait chercher à obtenir une certaine protection contre d'autres services radio fonctionnant dans les mêmes bandes de télévision, une licence radio serait requise. Pour en savoir plus, veuillez consulter le document CPC-2-1-28 d'Industrie Canada intitulé, Délivrance de licences sur une base volontaire pour les appareils radio de faible puissance exempts de licence et exploités dans les bandes de télévision.

**Per RSS-Gen**

This device complies with Industry Canada's license-exempt RSSs. Operation is subject to the following two conditions:

- 1) This device may not cause interference
- 2) This device must accept any interference, including interference that may cause undesired operation of the device.

Le présent appareil est conforme aux CNR d'Industrie Canada applicables aux appareils radio ex-empts de licence. L'exploitation est autorisée aux deux conditions suivantes :

- 1) l'appareil ne doit pas produire de brouillage;
- 2) l'appareil doit accepter tout brouillage radioélectrique subi, même si le brouillage est susceptible d'en compromettre le fonctionnement.

**ISED Notice to the End User:**

The normal condition of using this device is to keep the hand at least 20mm away from the base of the microphone.

La condition normale d'utilisation de cet appareil est de garder la main à au moins 20 mm de la base du microphone.



## Service and Repair

If your system malfunctions, you should attempt to correct or isolate the trouble before concluding that the equipment needs repair. Make sure you have followed the setup procedure and operating instructions. Check the inter-connecting cables and then go through the **Troubleshooting** section in this manual.

We strongly recommend that you **do not** try to repair the equipment yourself and **do not** have the local repair shop attempt anything other than the simplest repair. If the repair is more complicated than a broken wire or loose connection, send the unit to the factory for repair and service. Don't attempt to adjust any controls inside the units. Once set at the factory, the various controls and trimmers do not drift with age or vibration and never require readjustment. **There are no adjustments inside that will make a malfunctioning unit start working.**

LECTROSONICS' Service Department is equipped and staffed to quickly repair your equipment. In-warranty repairs are made at no charge in accordance with the terms of the warranty. Out-of-warranty repairs are charged at a modest flat rate plus parts and shipping. Since it takes almost as much time and effort to determine what is wrong as it does to make the repair, there is a charge for an exact quotation. We will be happy to quote approximate charges by phone for out-of-warranty repairs.

### Returning Units for Repair

For timely service, please follow the steps below:

- A. DO NOT return equipment to the factory for repair without first contacting us by letter or by phone. We need to know the nature of the problem, the model number and the serial number of the equipment. We also need a phone number where you can be reached 8 A.M. to 4 P.M. (U.S. Mountain Standard Time).
- B. After receiving your request, we will issue you a return authorization number (R.A.). This number will help speed your repair through our receiving and repair departments. The return authorization number must be clearly shown on the **outside** of the shipping container.
- C. Pack the equipment carefully and ship to us, shipping costs prepaid. If necessary, we can provide you with the proper packing materials. UPS is usually the best way to ship the units. Heavy units should be "double-boxed" for safe transport.
- D. We also strongly recommend that you insure the equipment, since we cannot be responsible for loss of or damage to equipment that you ship. Of course, we insure the equipment when we ship it back to you.

**Mailing address:**  
Lectrosonics, Inc.  
PO Box 15900  
Rio Rancho, NM 87174  
USA

**Shipping address:**  
Lectrosonics, Inc.  
581 Laser Rd.  
Rio Rancho, NM 87124  
USA

**Telephone:**  
(505) 892-4501  
(800) 821-1121 Toll-free  
(505) 892-6243 Fax

**Web:**  
www.lectrosonics.com

**E-mail:**  
sales@lectrosonics.com

#### Lectrosonics Canada:

**Mailing Address:**  
720 Spadina Avenue,  
Suite 600  
Toronto, Ontario M5S 2T9

**Telephone:**  
(416) 596-2202  
(877) 753-2876 Toll-free  
(877-7LECTRO)  
(416) 596-6648 Fax

**E-mail:**  
Sales: colinb@lectrosonics.com  
Service: joe@lectrosonics.com





## LIMITED ONE YEAR WARRANTY

The equipment is warranted for one year from date of purchase against defects in materials or workmanship provided it was purchased from an authorized dealer. This warranty does not cover equipment which has been abused or damaged by careless handling or shipping. This warranty does not apply to used or demonstrator equipment.

Should any defect develop, Lectrosonics, Inc. will, at our option, repair or replace any defective parts without charge for either parts or labor. If Lectrosonics, Inc. cannot correct the defect in your equipment, it will be replaced at no charge with a similar new item. Lectrosonics, Inc. will pay for the cost of returning your equipment to you.

This warranty applies only to items returned to Lectrosonics, Inc. or an authorized dealer, shipping costs prepaid, within one year from the date of purchase.

This Limited Warranty is governed by the laws of the State of New Mexico. It states the entire liability of Lectrosonics Inc. and the entire remedy of the purchaser for any breach of warranty as outlined above. **NEITHER LECTROSONICS, INC. NOR ANYONE INVOLVED IN THE PRODUCTION OR DELIVERY OF THE EQUIPMENT SHALL BE LIABLE FOR ANY INDIRECT, SPECIAL, PUNITIVE, CONSEQUENTIAL, OR INCIDENTAL DAMAGES ARISING OUT OF THE USE OR INABILITY TO USE THIS EQUIPMENT EVEN IF LECTROSONICS, INC. HAS BEEN ADVISED OF THE POSSIBILITY OF SUCH DAMAGES. IN NO EVENT SHALL THE LIABILITY OF LECTROSONICS, INC. EXCEED THE PURCHASE PRICE OF ANY DEFECTIVE EQUIPMENT.**

This warranty gives you specific legal rights. You may have additional legal rights which vary from state to state.

