

Tensioned Cosmopolitan® Electrol®

Automatic Electric Projection Screen Model



SPECIFICATION DATA

SUGGESTED SPECIFICATIONS: _____ projection screen(s), _____ (H) x _____ (W), electrically operated 120 volt (60 Hz) not more than 2.4 amp. To have seamless surfaces with black masking borders standard on flame retardant and mildew resistant fabric mounted on rigid metal roller. Each side of the fabric to have tab guide cable system to maintain even lateral tension and hold surface flat. Custom slat bar with added weight maintains vertical tension on the screen surface. The ends of the slat to be protected by heavy duty plastic caps enclosing a preset adjustable mechanism for screen tensioning. Shall have specially designed motor mounted inside the roller, to be three wire with ground, quick reversal type, oiled for life, with automatic thermal overload cutout, integral gears, capacitor and an electric brake to

prevent coasting. To have preset but adjustable limit switches to automatically stop picture surface in the "up" and "down" position. Case to be powder coated white 21-gauge steel, hexagon in shape with flat back to prevent scraping fabric. Case end caps to be heavy duty, allowing no exposed roller pins. Caps shall form sturdy brackets for wall or ceiling installation. To be complete with three position control switch with cover plate. Screen to be listed by Underwriters' Laboratories.



HDTV (16:9) Format Dimensions

Viewing Area (H x W)		Nominal Diagonal		Overall Case Length		Between Hanger Eyes		Approx. Ship. Wt.	
In.	Cm	In.	Cm	In.	Cm	In.	Cm	Lbs.	Kg
45" x 80"	114 x 203	92"	234	98½"	250	97"	246	84	38.1
52" x 92"	132 x 234	106"	269	111"	282	109½"	278	91	41.3
54" x 96"	137 x 244	110"	279	115½"	293	114"	290	93	42.2
58" x 104"	147 x 264	119"	302	124"	315	122½"	311	100	45.4
65" x 116"	165 x 295	133"	338	137"	348	135½"	344	110	49.9
78" x 139"	198 x 353	159"	404	162"	411	160½"	408	130	59.0

Wide (16:10) Format Dimensions

Viewing Area (H x W)		Nominal Diagonal		Overall Case Length		Between Hanger Eyes		Approx. Ship. Wt.	
In.	Cm	In.	Cm	In.	Cm	In.	Cm	Lbs.	Kg
50" x 80"	127 x 203	94"	239	99"	251	97½"	248	83	37.6
57½" x 92"	146 x 234	109"	277	112"	284	110½"	281	89	40.4
60" x 96"	152 x 244	113"	287	116½"	296	115"	292	95	43.1
65" x 104"	165 x 264	123"	312	125"	318	123½"	314	102	46.3
69" x 110"	175 x 279	130"	330	131½"	334	130"	330	105	47.6
72½" x 116"	184 x 295	137"	348	138"	351	136½"	347	116	52.6
87" x 139"	221 x 353	164"	417	159"	404	157½"	400	130	59.0

Video (NTSC 4:3) Format Dimensions

Viewing Area (H x W)		Nominal Diagonal		Overall Case Length		Between Hanger Eyes		Approx. Ship. Wt.	
In.	Cm	In.	Cm	In.	Cm	In.	Cm	Lbs.	Kg
43" x 57"	109 x 145	72"	183	75"	191	73½"	187	63	28.6
50" x 67"	127 x 170	84"	213	86"	218	84½"	215	72	32.7
60" x 80"	152 x 203	100"	254	100"	254	98½"	250	83	37.6
69" x 92"	175 x 234	120"	305	114"	290	112½"	286	96	43.5
87" x 116"	221 x 295	150"	381	141"	358	139½"	354	118	53.5

PRODUCT NOTES

- All viewing surfaces will be seamless.
- All viewing surfaces are standard with black backing except Da-Tex® and Dual Vision.
- High Contrast Cinema Perf available in sizes up to 87" x 116" in Video Format and 78" x 139" in HDTV Format.
- All screens standard with 12" black drop at the top.
- Extra drop may alter dimensions. Contact Da-Lite for details.
- Overall case length dimensions +/- ¼" (6mm).
- Specifications subject to change without notice.
- Custom formats and sizes available upon request.

WHEN ORDERING, MARK APPROPRIATE SELECTIONS:

1. Select size from charts on the other side.
2. Select viewing surface (All Da-Lite surfaces are GREENGUARD GOLD Certified.):
 - Da-Mat®
 - High Contrast Da-Mat®
 - Dual Vision
 - Da-Tex® (Rear)

3. Options:

- Single Motor Low Voltage Control (LVC) - built-in.
- Wireless Remote Control for LVC.
 - Radio Frequency Remote.
 - Radio Frequency Range Extender available.
 - Infrared Remote.
- Silent Motor.
- Silent Motor with Integrated LVC.
- 220 Volt (50 Hz) Motor.
- Video Projector Interface Control - built-in (120V motor only).
- Black case (white standard).

4. Optional Accessories:

- Single Motor Low Voltage Control (LVC) - external.
- Key Locking Cover Plate for 120V or LVC Switch.
- Key Operated Switch for 120V only (**NOTE:** Cannot be used with LVC).
- Video Projector Interface Control - external.
- Floating Mounting Bracket (black or white). Recommended for drywall installations.
- No. 6 Wall Bracket - 6" extension, non-adjustable (140# maximum per pair) (black or white).
- Ceiling Trim Kit. Built in LVC recommended.
- External SCB-100 - RS-232 Serial Control Board.
- NET-100 Ethernet-Serial Adapter

PRODUCT VIEWS

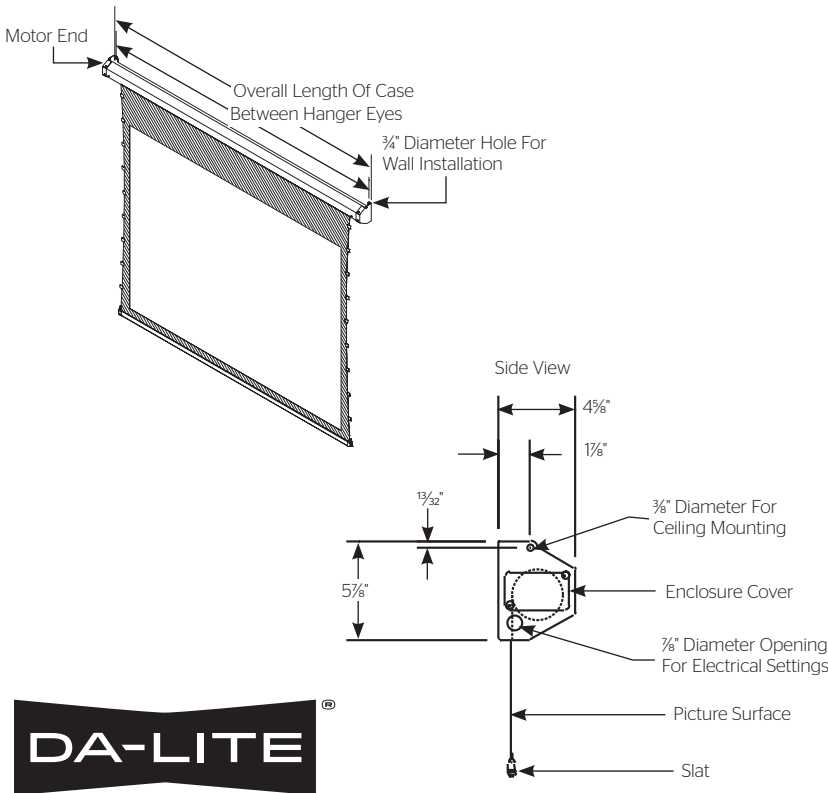

A BRAND OF MILESTONE AV TECHNOLOGIES

www.milestone.com
 P 800.622.3737 / 574.267.8101
 F 877.325.4832 / 574.267.7804
 E info@da-lite.com

In British Columbia, Milestone AV Technologies ULC carries on business as MAVT Milestone AV Technologies ULC.

©2018 Milestone AV Technologies. DL-0240 (Rev. 4) 0218. Da-Lite is a registered trademarks of Milestone AV Technologies. All other brand names or marks are used for identification purposes and are trademarks of their respective owners. All patents are protected under existing designations. Other patents pending.

SUGGESTED METHOD OF INSTALLATION

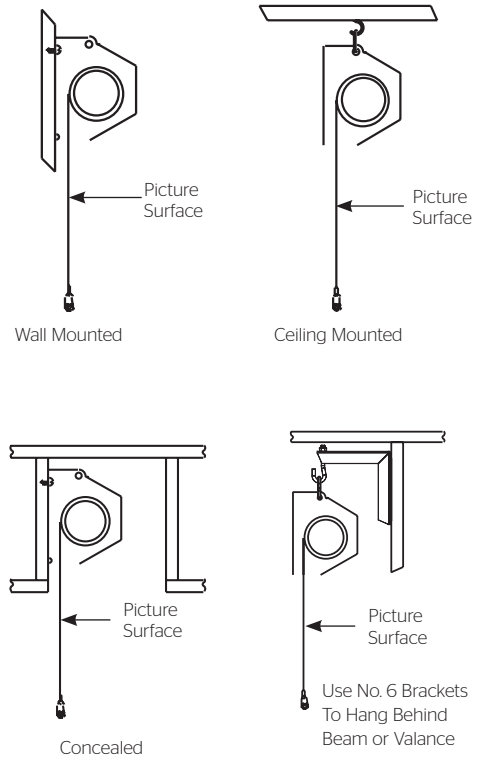

Project Name: _____

Architect: _____

Contractor: _____ Phone: _____

Reseller: _____ Phone: _____