

# INSTRUCTION SHEET

# VWM SERIES

## PIVOTING MOUNTING RAIL BRACKET OPTION

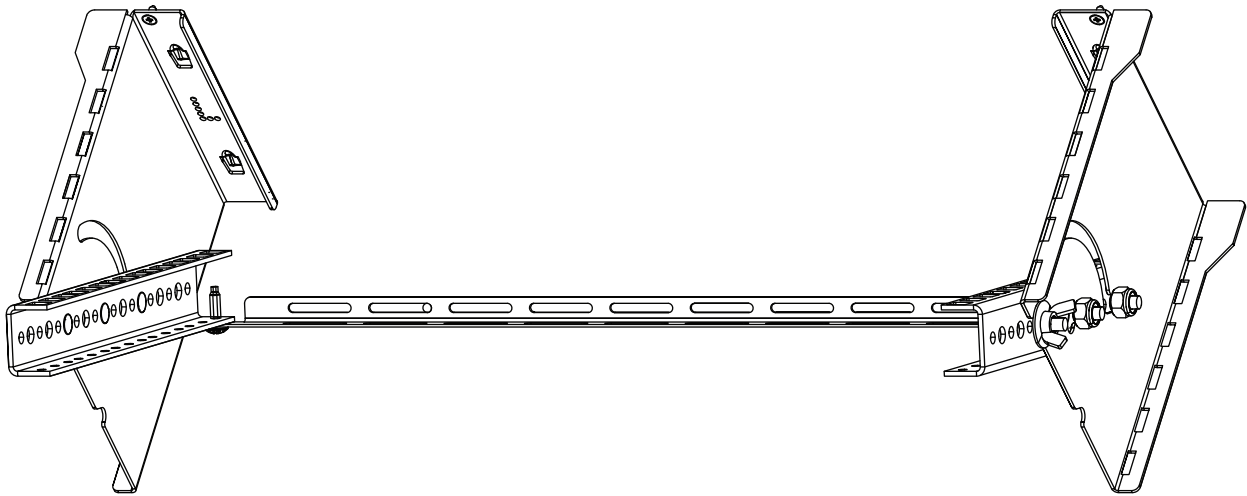

### THANK YOU

Thank you for purchasing a VWM Pivoting Mounting Rail Bracket option. Please read these instructions thoroughly before installing or assembling this product. For more information, refer to the VWM Series Vertical Wall Mount Rack Instruction Sheet (I-00796).

### PRODUCT FEATURES

- Rail includes 10-32 and cagenut sides
- Pivots 100°



## SAVE ALL INSTRUCTIONS / CONSERVER CES INSTRUCTIONS



### DANGER HAZARDOUS VOLTAGE/DANGER HAUTE TENSION

The lightning flash with the arrowhead symbol, within an equilateral triangle is intended to alert the user to the presence of uninsulated dangerous voltage within the product's enclosure that may be of sufficient magnitude to constitute a risk of electric shock to persons.

L'éclair avec le symbole de flèche dans un triangle équilatéral est destiné à alerter l'utilisateur de la présence d'une tension dangereuse non isolée dans l'enceinte du produit qui peut être d'une ampleur suffisante pour constituer un risque de choc électrique pour les personnes.



CAUTION/ATTENTION The exclamation point within an equilateral triangle is intended to alert the user to the presence of important operating and maintenance (servicing) instructions in the literature accompanying the appliance.

Le point d'exclamation dans un triangle équilatéral est destiné à alerter l'utilisateur de la présence d'importantes instructions d'opération et de maintenance (entretien) dans la documentation accompagnant l'appareil.



**WARNING:** Failure to read, understand and follow the following information can result in serious personal injury, damage to the equipment or voiding of the warranty.

**AVERTISSEMENT:** Ne pas lire, comprendre et suivre les informations suivantes peut entraîner des blessures graves, des dommages à l'équipement ou de la nullité de la garantie.



**CAUTION:** All installation and assembly steps must be performed by qualified personnel.

**ATTENTION:** Toutes installation et de montage étapes doivent être effectuées par du personnel qualifié.



**CAUTION:** Ensure that the wall has a structural load capacity that will support the weight of the cabinet fully loaded with equipment.

**ATTENTION:** Veiller à ce que le mur a une capacité de charge structurelle qui supporter le poids de le cabinet entièrement chargé avec l'équipement .



**CAUTION:** Individual components mounted inside of the wall mount rack must have their own fire enclosure.

**ATTENTION:** Les composants individuels montés à l'intérieur du rack doivent avoir leur propre enceinte coupe-feu.

## IMPORTANT SAFETY INSTRUCTIONS / INSTRUCTIONS IMPORTANTES SUR LA SÉCURITÉ



**CAUTION:** The following parts are not effectively bonded to the protective earth terminal: Rack rails, lacer bars, Lever Lock™ shelves, baffle, blanking panels, and cable management. If any part needs to be bonded to the protective earth terminal it shall be done in accordance with Article 250 of the National Electrical Code.

**ATTENTION:** Les pièces suivantes ne sont pas effectivement liés à la borne de terre de protection: rails de rack, bars à lacer, verrouillage de levier, étagères, déflecteurs, des panneaux d'obturation, et de gestion de câble. Si une partie doit être lié à la borne de terre de protection, il doit être fait conformément à l'article 250 du Code national de l'électricité.



**CAUTION:** Power cord(s), for fans or other accessories, need to be secured to ensure that they are routed away from pinch points and moving parts.

**ATTENTION:** Le cordon d'alimentation (s), pour les fans ou autres accessoires, doivent être fixé à veiller à ce que ils sont acheminés loin des points de pincement et des pièces mobiles.



**CAUTION:** To reduce the risk of personal injury, these mounting instructions must be followed and proper weight capacities must be observed.

**ATTENTION:** Pour réduire le risque de blessures, ces instructions de montage doivent être respectées et les capacités de poids appropriées doivent être respectées.

### WEIGHT RATINGS

Model	Weight Rating
Pivoting Mounting Rail Bracket Option	20 lbs. Maximum Total Rated Load

## SUPPLIED COMPONENTS AND HARDWARE

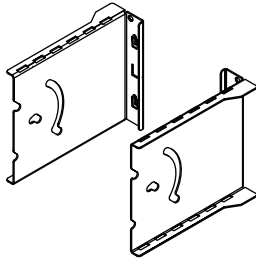

Pivot Bracket Set

A

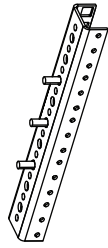

(2x) 10-32 and  
Cage Nut Rackrail  
(Preinstalled on Bracket A)

B



(4x) 6-32 x 5/16 Phil.  
Bonding Screws

C

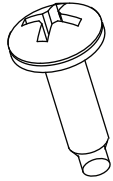

(2x) 10-32 x 3/4  
Phil. Screw

D

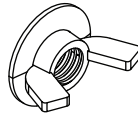

(2x) 15/16-18  
Flanged Wing Nut  
(Preinstalled on Bracket A)

E



(4x) 5/16-18 Hex Nut  
w/Nylon Insert  
(Preinstalled on Bracket A)

F

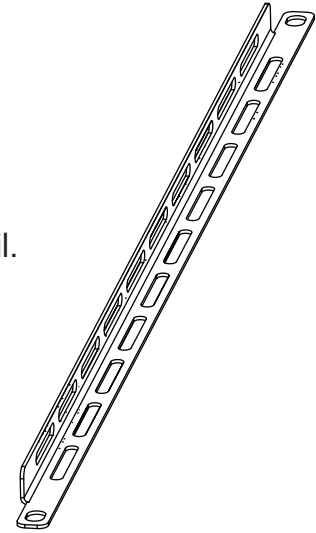

Lacer Bar

G

## REQUIRED TOOLS

- No. 2 Phillips Driver
- 3/8" Socket Wrench

## ROTATING PIVOT BRACKET RACKRAILS FROM 10-32 TO CAGENUT (IF DESIRED)

1. Remove the wing nut (E) and 5/16-18 nuts (F) from the studs on both rackrails (B). (**FIGURE A**)

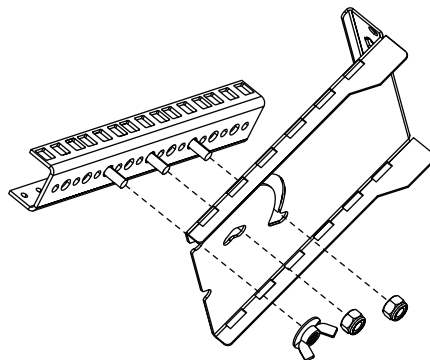

**FIGURE A**

2. Rotate the rackrails so the cagenut holes are positioned for use.
3. Reattach wing nuts and 5/16-18 nuts to the studs on both rackrails.

**NOTE:** Leave the 5/16-18 nuts loose enough so the rackrails pivot on the brackets.

## INSTALLING PIVOTING MOUNTING RAIL BRACKETS TO THE BACKPAN

### NOTE:

- Consider your equipment's power and cabling requirements to determine a left, center, or right bracket alignment.
- Pivoting mounting rail bracket pairs are labeled left (L) and right (R).

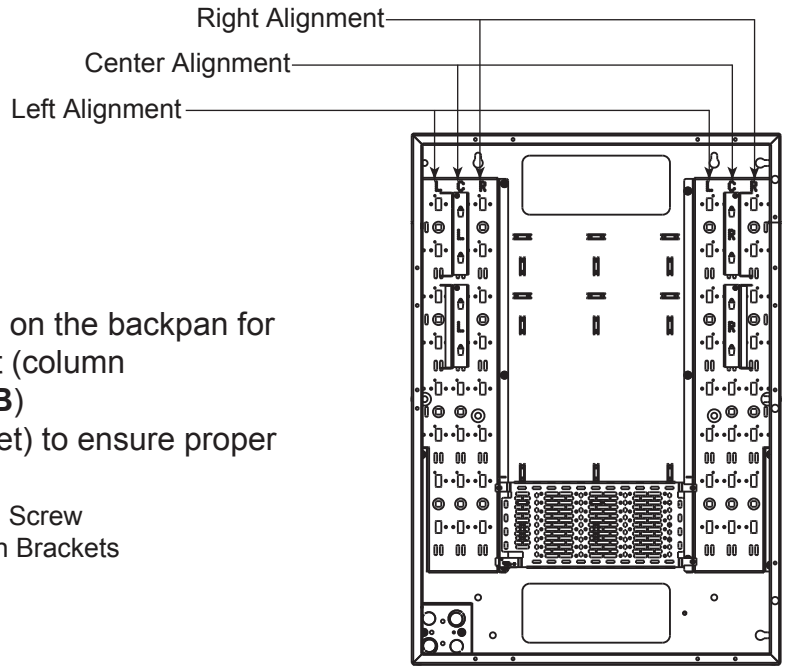

1. Install pivot brackets (A) to labeled columns on the backpan for left (column L), center (column C), and right (column R) alignment of your equipment. **(FIGURE B)**
2. Attach the bonding screws (C, 1x per bracket) to ensure proper bonding. **(FIGURE C)**

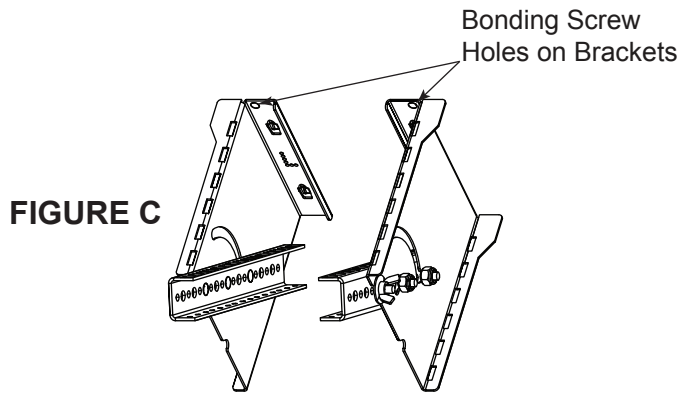

**FIGURE B**

**CAUTION!** The bonding screws must be used as explained to ensure proper bonding.

**ATTENTION!** Les vis doivent être utilisées comme expliqué pour assurer approprié électrique de liaison.

## USING THE PIVOTING MOUNTING RAIL BRACKETS

1. Loosen the wing nuts (E) on both sides of the rackrail, lift, and rotate the assembly from the in-use to punch down and service position. Tighten the wing nuts. Do not overtighten. **(FIGURE D)**

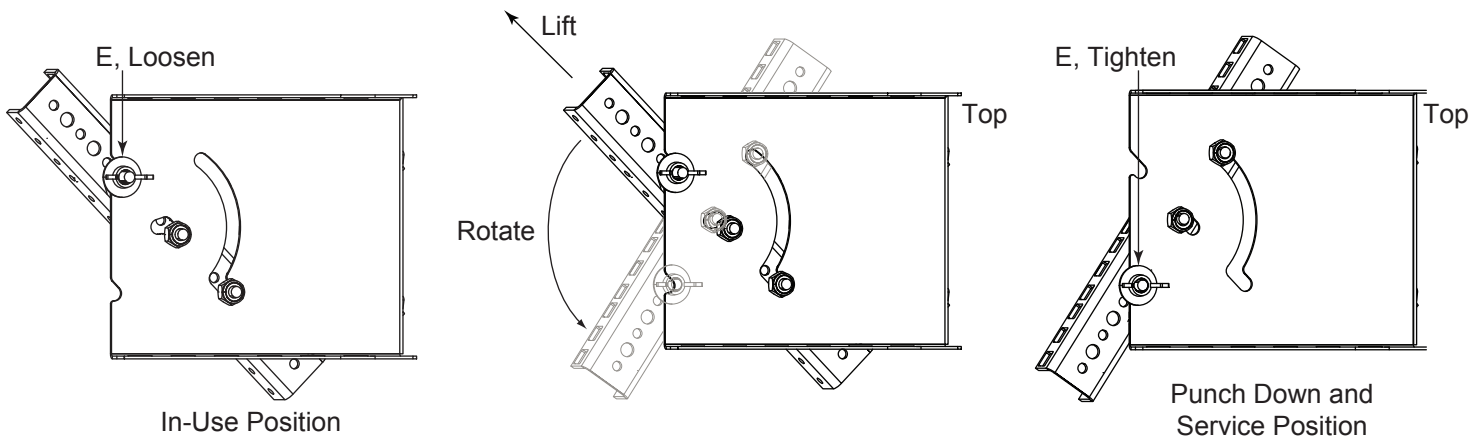

**FIGURE D**

2. When rotating, the bottom of the mounted component(s) swing forward for easier access to the connection points.

## INSTALLING THE LACER BAR

3. Use (2) 10-32 x 3/4 Phil. screws (D) to attach the lacer bar (G). (FIGURE E)

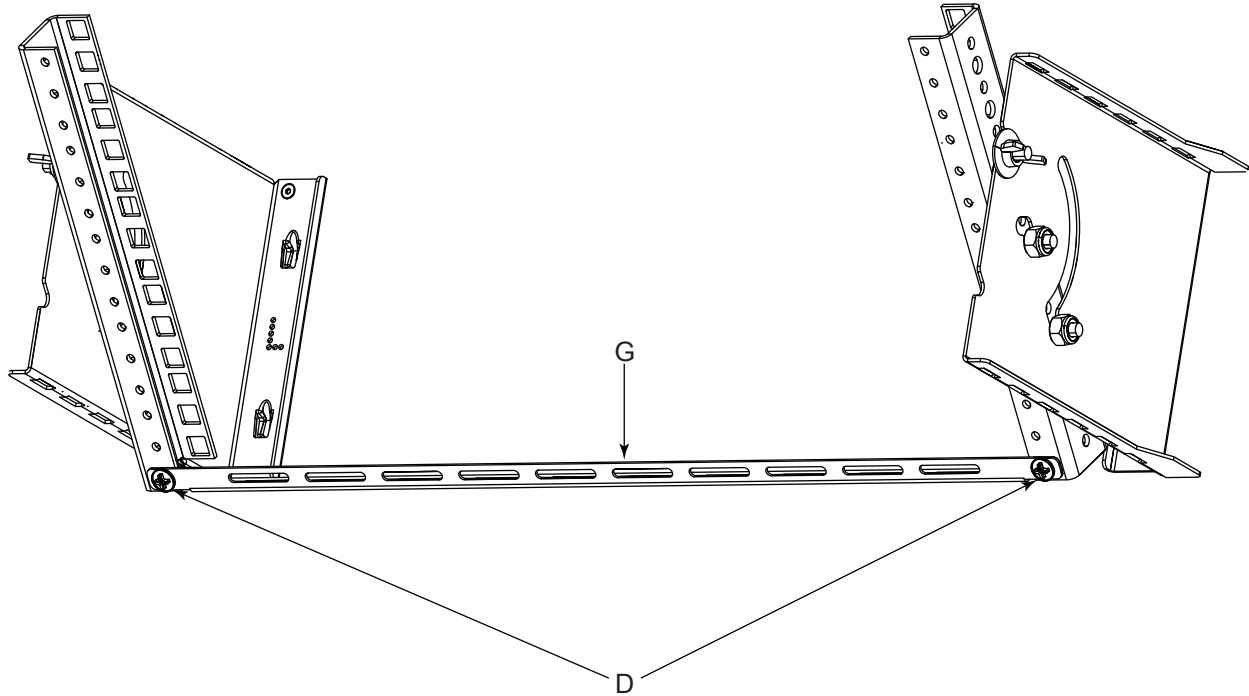

FIGURE E

## WARRANTY

For warranty information, refer to [www.middleatlantic.com/terms](http://www.middleatlantic.com/terms).

### Corporate Headquarters

Corporate Voice: 973-839-1011 - Fax: 973-839-1976 / International Voice: +1 973-839-8821

Fax: +1 973-839-4982

[www.middleatlantic.com](http://www.middleatlantic.com) - [info@middleatlantic.com](mailto:info@middleatlantic.com)

### Middle Atlantic Canada

Voice: 613-836-2501 - Fax: 613-836-2690 / [ca.middleatlantic.com](http://ca.middleatlantic.com) -

[customerservicecanada@middleatlantic.ca](mailto:customerservicecanada@middleatlantic.ca)

### Factory Distribution

USA: NJ - CA - IL Canada: ON - BC

**At Middle Atlantic Products we are always listening. Your comments are welcome.**

**Middle Atlantic Products is an ISO 9001 and ISO 14001 Registered Company.**