

INSTALLATION INSTRUCTIONS
PCD SERIES
PLASTIC CABLE DUCTS

MOUNTING DUAL CABLE DUCT BETWEEN 2 OR 4 POST RACKS

Using supplied hardware, install Brackets as shown (four places). See **FIGURE B** for appropriate orientation.

NOTE: Installed Brackets can be used for additional ganging (FIGURE C)

HARDWARE USED

 10-32 X .5" SCREW - 4 QTY

 10-32 NUT - 4 QTY

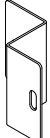
BRACKET - 4 QTY

NOTE: Brackets are pre-installed on one side

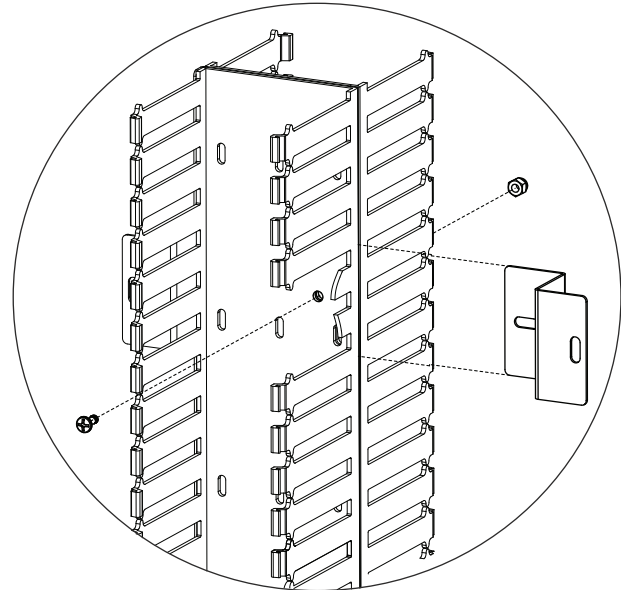

(FIGURE B)

Two Screws and Nuts per Bracket

(38RU/45RU)

(51RU)

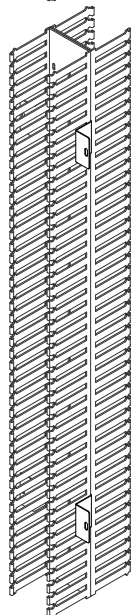
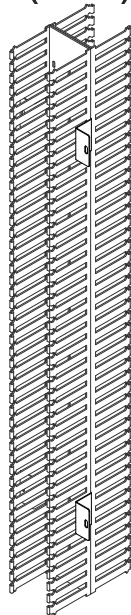
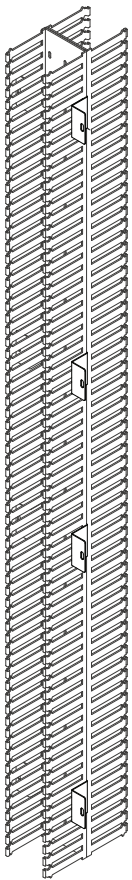

(FIGURE A)
Available sized Cable Ducts

**EXISTING BRACKET
ATTACHED TO RACK**

**INSTALLED BRACKET
FOR GANGING TO
ANOTHER RACK**

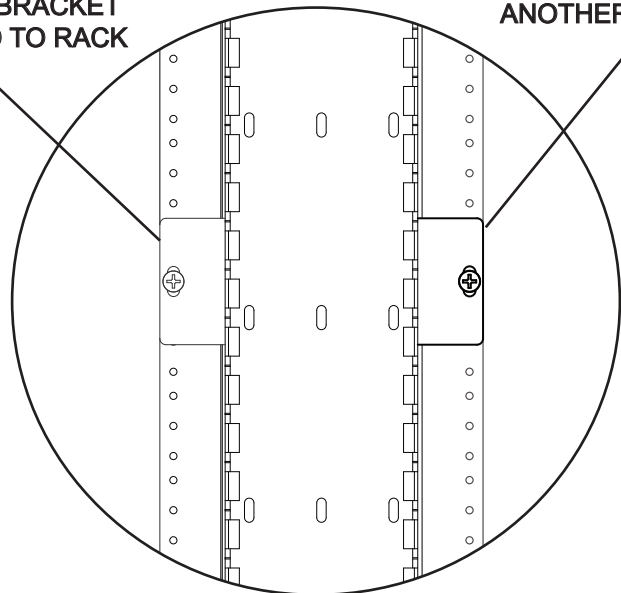

(FIGURE C)

Front View with existing and installed brackets

MOUNTING SINGLE CABLE DUCT BETWEEN 2 OR 4 POST RACKS

Using supplied hardware, install Brackets as shown (four places). See **FIGURE B** for appropriate orientation.

NOTE: Installed Brackets can be used for additional ganging (FIGURE C)

HARDWARE USED

 10-32 X .5" SCREW - 8 QTY

 10-32 NUT - 8 QTY

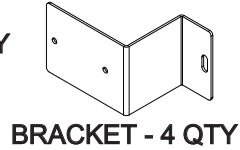

NOTE: Brackets are pre-installed on one side

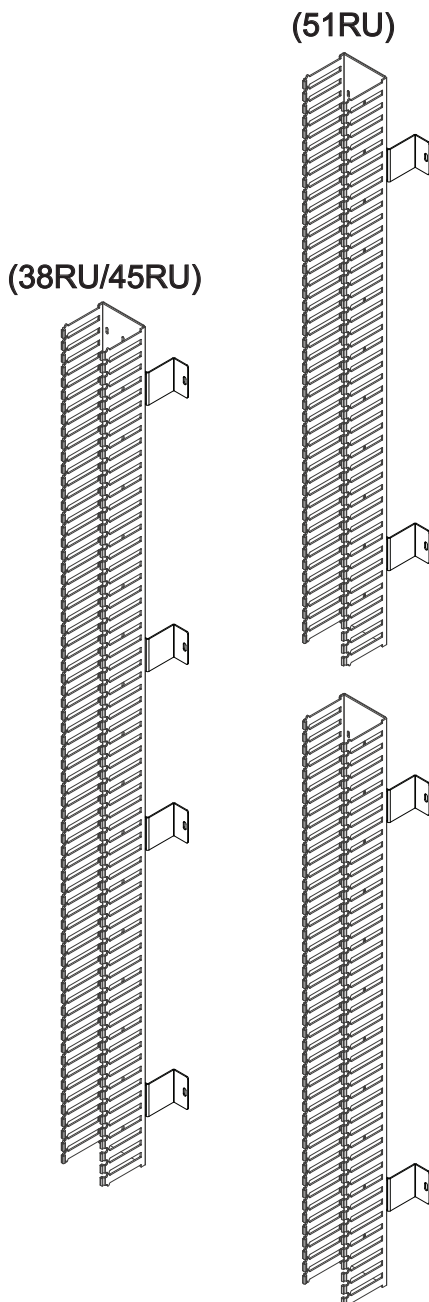

(FIGURE A)
Available sized Cable Ducts

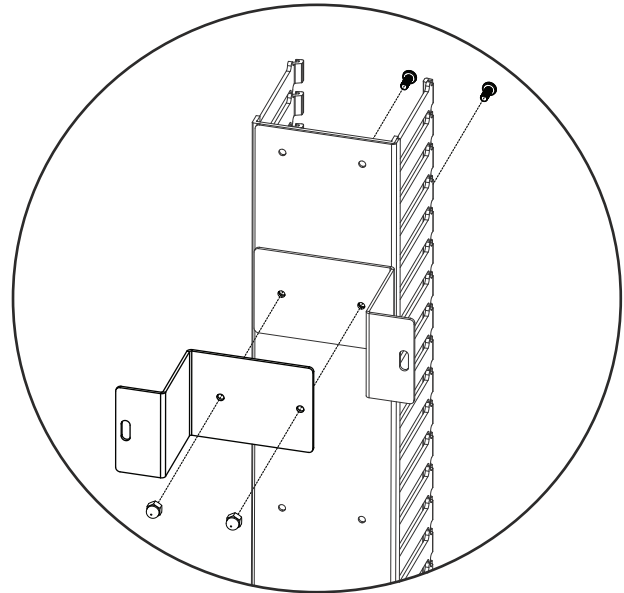

(FIGURE B)
Rear View showing
Two Screws and Nuts per Bracket

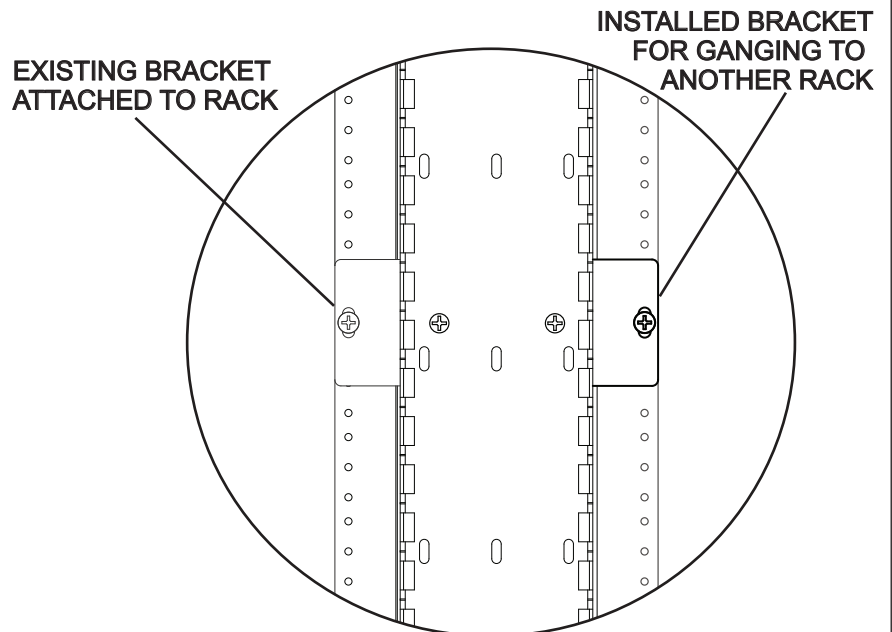

(FIGURE C)
Front View with existing and installed brackets

HINGE CLIP AND COVER INSTALLATION

The 'HINGE CLIP' connects the COVER to DUCTS, allowing the Cover to swing open and closed for optimum cable management.

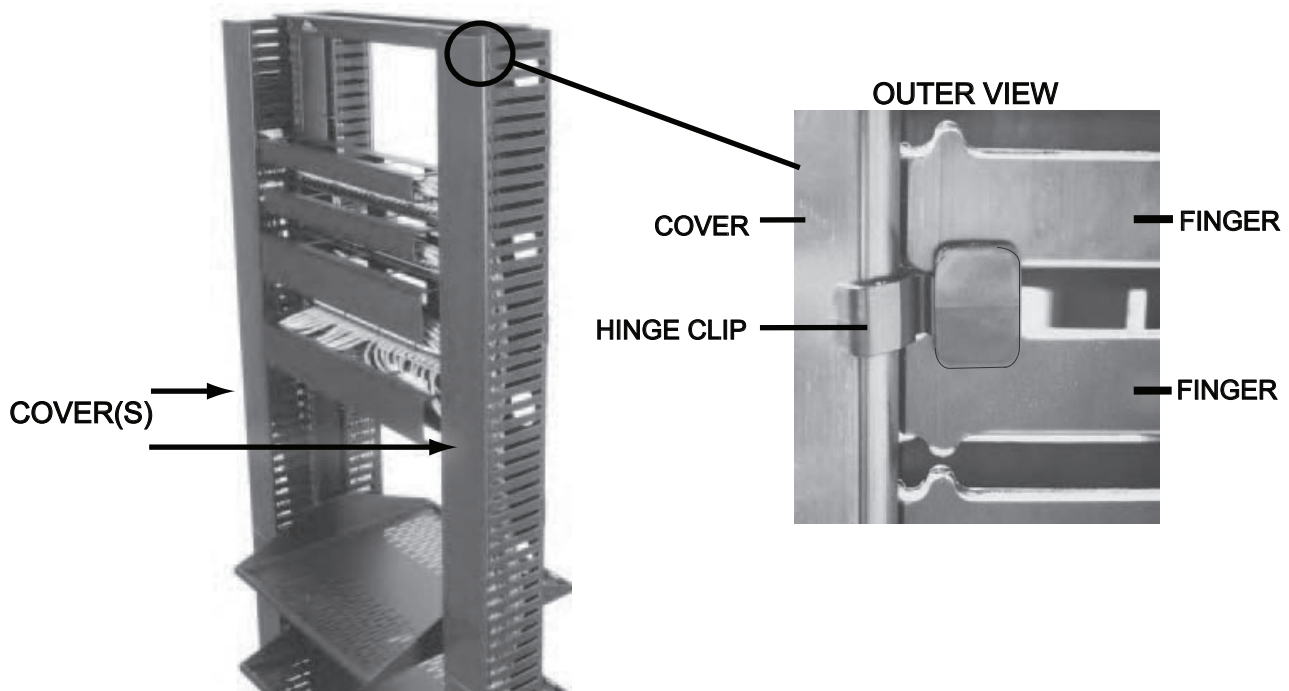

1) Slide the 'hook portion' of the Hinge Clip onto the Cover as shown. (FIGURE A)

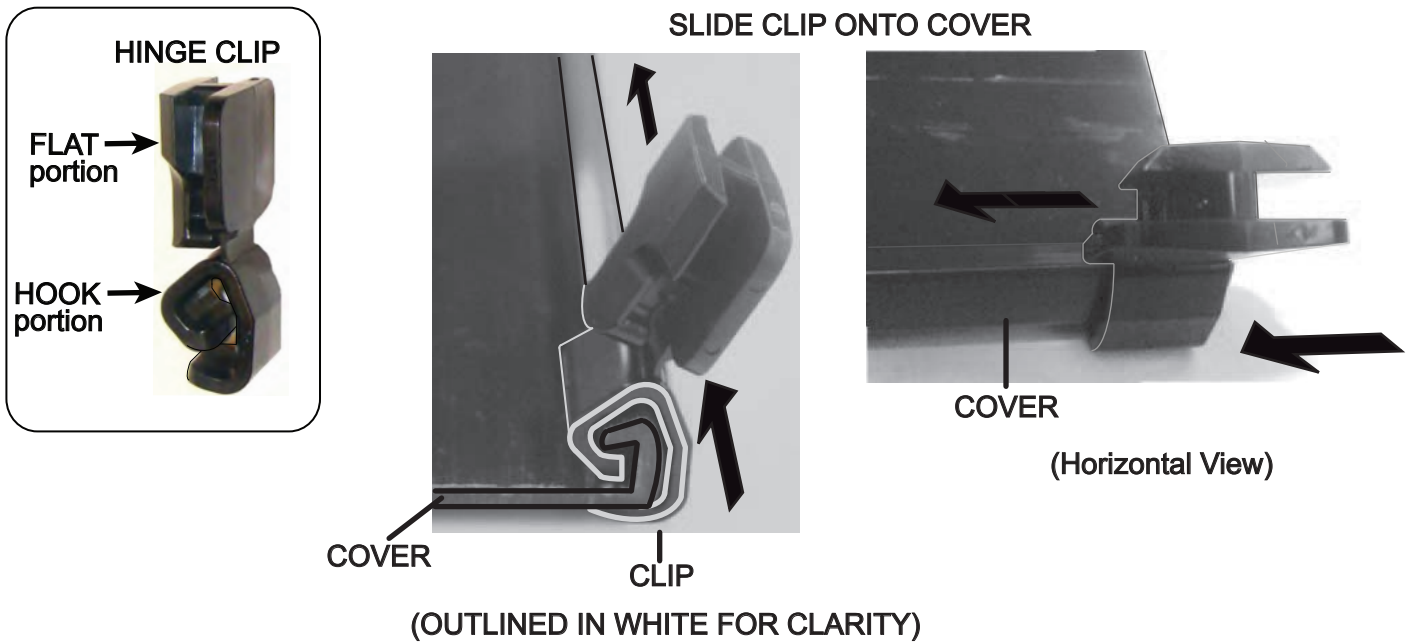
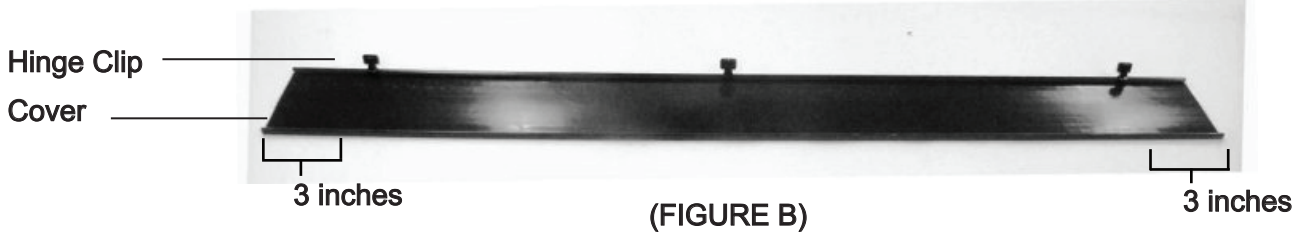
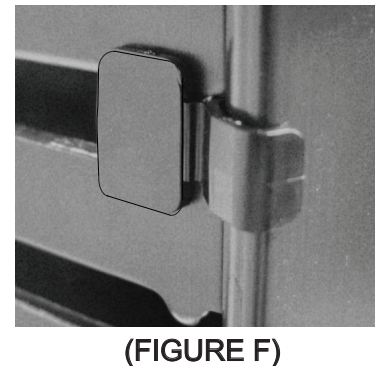
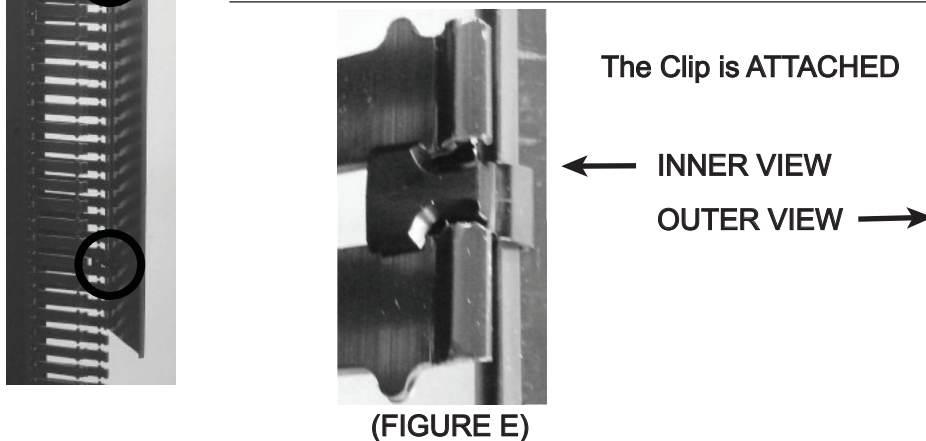
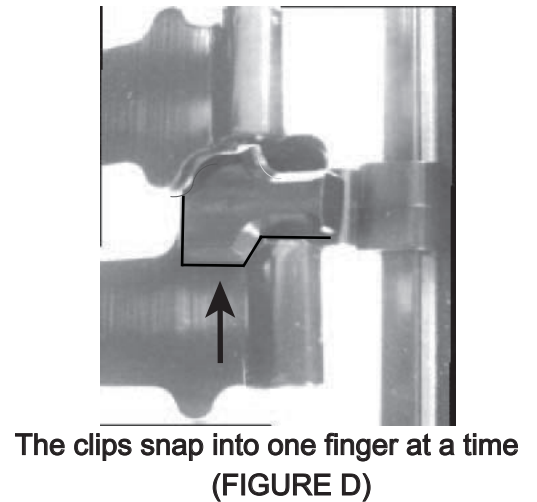
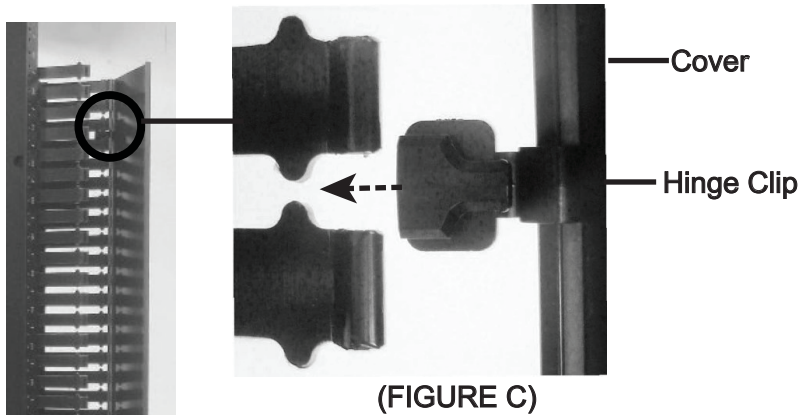

FIGURE A

RECOMMENDED: Space two (2) Hinge Clips three (3) inches from the cover edges, and one additional clip in the center portion of the cover as shown. (FIGURE B)



2) Once the clips are attached to the cover, align each clip beside and in-between two fingers. (FIGURE C)



WARRANTY

Middle Atlantic Products, Inc. (the "Company") warrants the Plastic Cable Ducts to be free from defects in material or workmanship under normal use and conditions for the lifetime of the product.

The Company's entire liability to the purchaser, and the purchaser's (or any other party's) sole and exclusive remedy, under this warranty shall be limited, at the Company's option, to either (a) return of and refund of the price paid for, or (b) repair or replacement at the Company's factory of the products purchased, or any part or parts thereof, which the Company has determined to be defective after inspection thereof at the Company's factory. This warranty does not cover damage due to acts of God, accident, misuse, abuse or negligence by parties other than the Company, or any modification or alteration of the products. In addition, this warranty does not cover damage due to improper handling, assembly, installation or maintenance.

THIS WARRANTY IS IN LIEU OF ALL OTHER WARRANTIES OF ANY KIND, EITHER EXPRESSED OR IMPLIED, INCLUDING, BUT NOT LIMITED TO, IMPLIED WARRANTIES OF MERCHANTABILITY AND FITNESS FOR A PARTICULAR PURPOSE.

TO THE MAXIMUM EXTENT PERMITTED BY APPLICABLE LAW, IN NO EVENT SHALL THE COMPANY BE LIABLE FOR ANY SPECIAL, INCIDENTAL, INDIRECT, OR CONSEQUENTIAL DAMAGES WHATSOEVER (INCLUDING, WITHOUT LIMITATION, DAMAGES FOR LOSS OF BUSINESS PROFITS, BUSINESS INTERRUPTION OR ANY OTHER PECUNIARY LOSS) ARISING OUT OF THE USE OF THE PRODUCTS PURCHASED, EVEN IF THE COMPANY HAS BEEN ADVISED OF THE POSSIBILITY OF SUCH DAMAGES. THE COMPANY'S LIABILITY TO THE PURCHASER (OR ANY OTHER PARTY) HEREUNDER, IF ANY, SHALL IN NO EVENT EXCEED THE PURCHASE PRICE OF THE PRODUCTS PAID TO THE COMPANY.

Corporate Headquarters

Corporate Voice 973-839-1011 - Fax 973-839-1976 / International Voice +1 973-839-8821 - Fax +1 973-839-4982
middleatlantic.com - info@middleatlantic.com

Middle Atlantic Canada

Voice 613-836-2501 - Fax 613-836-2690 / middleatlantic.ca - customerservicecanada@middleatlantic.ca

Factory Distribution

USA: NJ - CA - IL Canada: ON - BC

At Middle Atlantic Products we are always listening. Your comments are welcome.

Middle Atlantic Products is an ISO 9001 and ISO 14001 Registered Company.