

COLOUR 5 PROFILE™

user manual

©2015 **ELATION PROFESSIONAL** all rights reserved. Information, specifications, diagrams, images, and instructions herein are subject to change without notice. ELATION PROFESSIONAL logo and identifying product names and numbers herein are trademarks of ELATION PROFESSIONAL. Copyright protection claimed includes all forms and matters of copyrightable materials and information now allowed by statutory or judicial law or hereinafter granted. Product names used in this document may be trademarks or registered trademarks of their respective companies and are hereby acknowledged. All non-ELATION brands and product names are trademarks or registered trademarks of their respective companies.

ELATION PROFESSIONAL and all affiliated companies hereby disclaim any and all liabilities for property, equipment, building, and electrical damages, injuries to any persons, and direct or indirect economic loss associated with the use or reliance of any information contained within this document, and/or as a result of the improper, unsafe, insufficient and negligent assembly, installation, rigging, and operation of this product.

Elation Professional USA | 6122 S. Eastern Ave. | Los Angeles, CA. 90040
323-582-3322 | 323-832-9142 fax | www.elationlighting.com | info@elationlighting.com

Elation Professional B.V. | Junostraat 2 | 6468 EW Kerkrade, Netherlands
+31 45 546 85 66 | +31 45 546 85 96 fax | www.elationlighting.eu | info@elationlighting.eu

DOCUMENT VERSION



Please check www.elationlighting.com for the latest revision/update of this manual.

Date	Document Version	Software Version	DMX Channel Modes	Notes
5/2015	1	≥1.0.1	5 / 6 / 8 / 13 / 19	ETL version.

CONTENTS

General Information	4
Warranty	6
Safety Instructions	7
General Guidelines	8
Fixture Overview	9
Lens and Gobo Holder Installation	10
Fixture Installation	11
Understanding DMX	14
Fixture Menu	18
DMX Channel Functions And Values	26
Cleaning and Maintenance	28
Technical Specifications	29
Optional Accessories	32

GENERAL INFORMATION

INTRODUCTION

Congratulations, you have just purchased one of the most innovative and reliable lighting fixtures on the market today! This fixture has been designed to perform reliably for years when the guidelines in this booklet are followed. Please read and understand the instructions in this manual carefully and thoroughly before attempting to operate this unit. These instructions contain important information regarding safety during use and maintenance.

UNPACKING

Every fixture has been thoroughly tested and has been shipped in perfect operating condition. Carefully check the shipping carton for damage that may have occurred during shipping. If the carton appears to be damaged, carefully inspect your unit for damage and be sure all accessories necessary to operate the unit have arrived intact. In the event damage has been found or parts are missing, please contact our customer support team for further instructions. Please do not return this unit to your dealer without first contacting customer support at the number listed below. Please do not discard the shipping carton in the trash. Please recycle whenever possible.

BOX CONTENTS

- (1) 5pin DMX Cable
- (1) powerCON Cable
- (1) Safety Cable
- Manual & Warranty Card

CUSTOMER SUPPORT

Elation Professional® provides a customer support line, to provide set up help and to answer any question should you encounter problems during your set up or initial operation. You may also visit us on the web at www.elationlighting.com for any comments or suggestions. For service related issue please contact Elation Professional®.

ELATION SERVICE USA - Monday - Friday 8:00am to 5:00pm PST

Voice: 323-582-3322

Fax: 323-832-9142

E-mail: support@elationlighting.com

ELATION SERVICE EUROPE - Monday - Friday 08:30 to 17:00 CET

Voice: +31 45 546 85 30

Fax: +31 45 546 85 96

E-mail: support@elationlighting.eu

WARRANTY REGISTRATION

Please fill out the enclosed warranty card to validate your purchase. All returned service items whether under warranty or not, must be freight pre-paid and accompany a return authorization (R.A.) number. The R.A. number must be clearly written on the outside of the return package. A brief description of the problem as well as the R.A. number must also be written down on a piece of paper and included in the shipping container. If the unit is under warranty, you must provide a copy of your proof of purchase invoice. Items returned without a R.A. number clearly marked on the outside of the package will be refused and returned at customer's expense. You may obtain a R.A. number by contacting customer support.

IMPORTANT NOTICE!



There are no user serviceable parts inside this unit. Do not attempt any repairs yourself; doing so will void your manufactures warranty. Damages resulting from modifications to this fixture and/or the disregard of safety and general user instructions found in this user manual void the manufactures warranty and are not subject to any warranty claims and/or repairs.

LIMITED WARRANTY

A. Elation Professional® hereby warrants, to the original purchaser, Elation Professional® products to be free of manufacturing defects in material and workmanship for a period of two years (730 days), and Elation Professional® product rechargeable batteries to be free of manufacturing defects in material and workmanship for a period of six months (180 days), from the original date of purchase. This warranty excludes discharge lamps and all product accessories. This warranty shall be valid only if the product is purchased within the United States of America, including possessions and territories. It is the owner's responsibility to establish the date and place of purchase by acceptable evidence, at the time service is sought.

B. For warranty service, send the product only to the Elation Professional® factory. All shipping charges must be pre-paid. If the requested repairs or service (including parts replacement) are within the terms of this warranty, Elation Professional® will pay return shipping charges only to a designated point within the United States. If any product is sent, it must be shipped in its original package and packaging material. No accessories should be shipped with the product. If any accessories are shipped with the product, Elation Professional® shall have no liability what so ever for loss and/or or damage to any such accessories, nor for the safe return thereof.

C. This warranty is void if the product serial number and/or labels are altered or removed; if the product is modified in any manner which Elation Professional® concludes, after inspection, affects the reliability of the product; if the product has been repaired or serviced by anyone other than the Elation Professional® factory unless prior written authorization was issued to purchaser by Elation Professional®; if the product is damaged because not properly maintained as set forth in the product instructions, guidelines and/or user manual.

D. This is not a service contract, and this warranty does not include any maintenance, cleaning or periodic check-up. During the periods as specified above, Elation Professional® will replace defective parts at its expense, and will absorb all expenses for warranty service and repair labor by reason of defects in material or workmanship. The sole responsibility of Elation Professional® under this warranty shall be limited to the repair of the product, or replacement thereof, including parts, at the sole discretion of Elation Professional®. All products covered by this warranty were manufactured after January 1, 1990, and bare identifying marks to that effect.

E. Elation Professional® reserves the right to make changes in design and/or performance improvements upon its products without any obligation to include these changes in any products theretofore manufactured.

F. No warranty, whether expressed or implied, is given or made with respect to any accessory supplied with the products described above. Except to the extent prohibited by applicable law, all implied warranties made by Elation Professional® in connection with this product, including warranties of merchantability or fitness, are limited in duration to the warranty periods set forth above. And no warranties, whether expressed or implied, including warranties of merchantability or fitness, shall apply to this product after said periods have expired. The consumer's and/or dealer's sole remedy shall be such repair or replacement as is expressly provided above; and under no circumstances shall Elation Professional® be liable for any loss and/or damage, direct and/or consequential, arising out of the use of, and/or the inability to use, this product.

G. This warranty is the only written warranty applicable to Elation Professional® products and supersedes all prior warranties and written descriptions of warranty terms and conditions heretofore published.

SAFETY INSTRUCTIONS



This fixture is an extremely sophisticated piece of electronic equipment. To guarantee a smooth operation, it is important to follow the guidelines in this manual. The manufacturer of this device will not accept responsibility for damages resulting from the misuse of this fixture due to the disregard of the information printed in this manual.



This device falls under **PROTECTION CLASS 1**. It's essential this device be grounded properly. Only qualified personnel should perform all electrical connections.



KEEP THIS FIXTURE AWAY FROM RAIN AND MOISTURE!



UNPLUG POWER BEFORE SERVICING FIXTURE



NEVER TOUCH FIXTURE DURING OPERATION AS IT MAY BE HOT



**NEVER LOOK DIRECTLY INTO THE LIGHT SOURCE
SENSITIVE PERSONS MAY SUFFER AN EPILEPTIC SHOCK**

- For proper operation, follow the **Installation** guidelines described in this manual. Only qualified and certified personnel should perform installation of this fixture and only the original rigging parts (brackets) included with this fixture should be used for installation. Any modifications will void the original manufacturer's warranty and increase the risk of damage and/or personal injury.
- Never look directly into the light source of this fixture to prevent risk of injury to your retina, which may induce blindness. Those suffering from **EPILEPSY** should avoid looking directly into the light source of this unit at all times.
- The fan and air inlets must remain clean and never blocked. Allow approx. 6" (15cm) between this fixture and other devices or a wall for proper cooling.
- Always disconnect from main power source before performing any type of service and/or cleaning procedure. Only handle the power cord by the plug end, never pull out the plug by tugging the wire portion of the cord.
- Do not operate this fixture if the power cord has become frayed, crimped and/or damaged. If the power cord is damaged, replace it immediately with a new one of similar power rating.

GENERAL GUIDELINES

- **NEVER OPEN THIS FIXTURE WHILE IN USE!**
- During the initial operation of this fixture, a light smoke or smell may emit from the interior of the fixture. This is a normal process and is caused by excess paint in the interior of the casing burning off from the heat associated with the lamp and will decrease gradually over time.
- This fixture is a professional lighting effect designed for **INDOOR / DRY LOCATIONS ONLY** on stage, in nightclubs, theatres, etc.
- Please make sure there are **NO FLAMMABLE MATERIALS** close to the fixture while operating, to prevent any fire hazard.
- The fixture must be installed in a location with adequate ventilation, at least 1.5 feet (.5m) from adjacent surfaces. Be sure no air ventilation slots are blocked.
- **DO NOT** attempt installation and/or operation without knowledge how to do so.
- **DO NOT** permit operation by persons who are not qualified to operate this type of fixture. Most damages are the result of operations by nonprofessionals.
- Consistent operational breaks may ensure the fixture will function properly for many years to come.
- **DO NOT** shake fixture, avoid brute force when installing and/or operating fixture.
- Always install the fixture with an appropriate safety cable. When installing the fixture in a suspended environment, always use mounting hardware that is no less than M10 x 25 mm, also be sure the hardware is insert in the pre-arranged screw holes in the bracket of the fixture.
- Use the original packaging and materials to transport the fixture in for service.
- **DO NOT TOUCH** the housing bare-hand during its operation. Turn OFF the power and allow approximately 15 minutes for the fixture to cool down before replacing or serving.

FIXTURE OVERVIEW

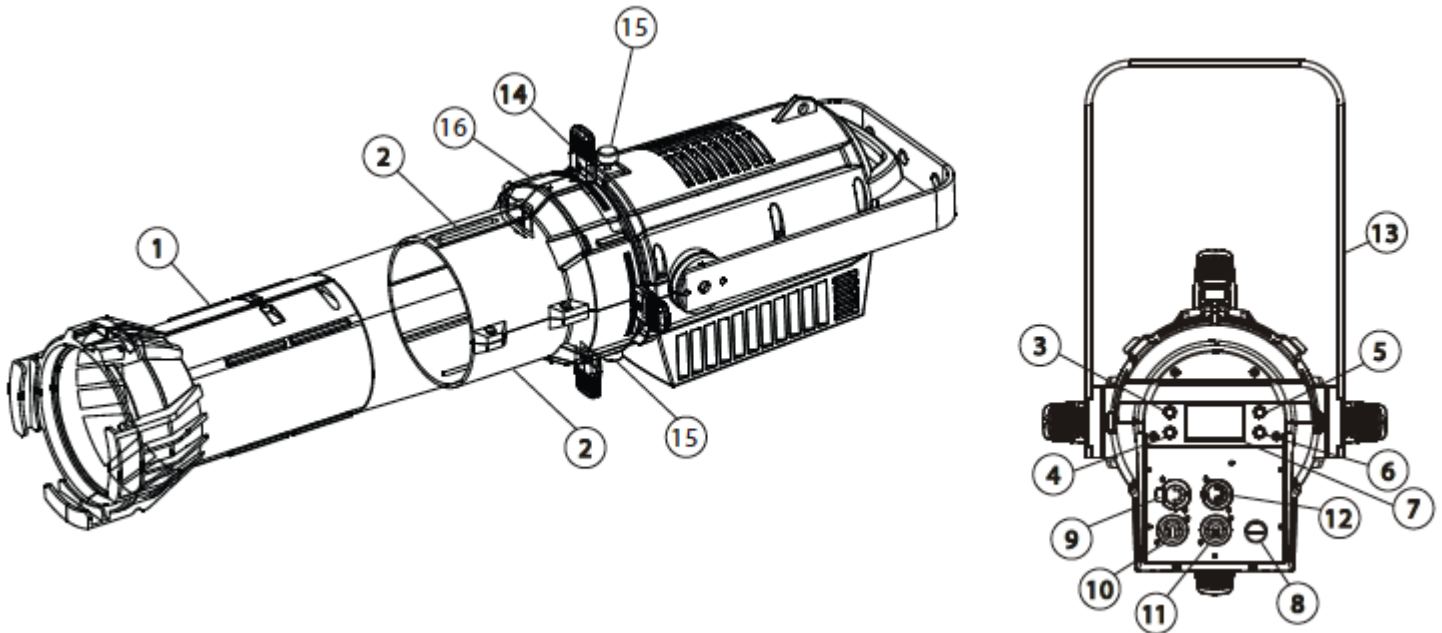

- | | |
|-----------------------------|--------------------|
| 1. Lens (not included) | 9. 5pin DMX OUT |
| 2. FOCUS | 10. powerCON OUT |
| 3. UP Button | 11. powerCON IN |
| 4. DOWN Button | 12. 5pin DMX IN |
| 5. MODE/ESC Button | 13. Mounting Yoke |
| 6. ENTER Button | 14. BLADE SHUTTERS |
| 7. LCD Menu Control Display | 15. ROTATION |
| 8. FUSE | 16. Gobo Slot* |
- *Gobo and Holder not included**

LENS AND GOBO HOLDER INSTALLATION

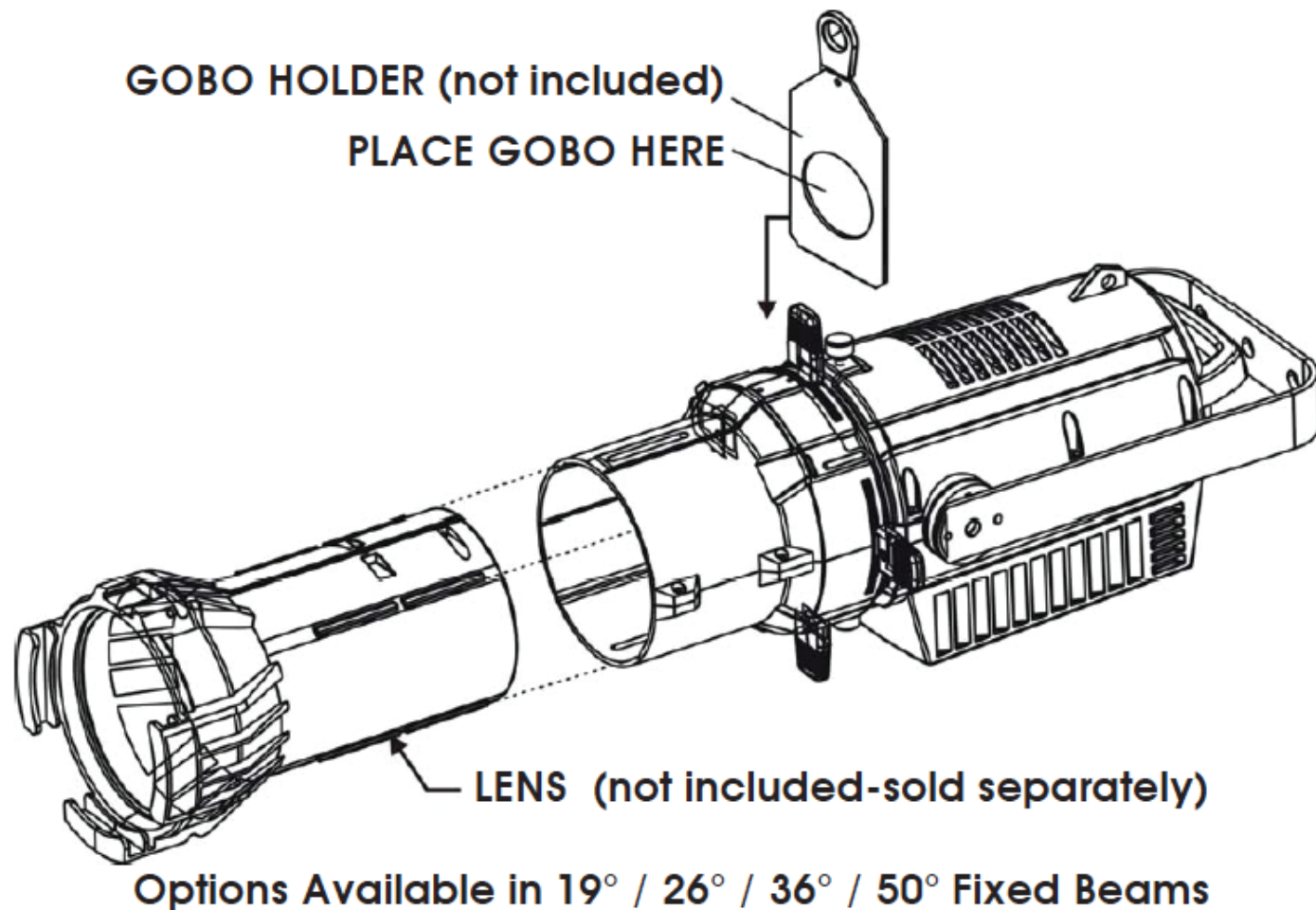

Gobo Holder (not included)

Supports "B" Size Metal and HT Transparency Gobos (not included)

FIXTURE INSTALLATION



FLAMMABLE MATERIAL WARNING

Keep fixture at least 5.0 ft. (1.5m) away from any flammable materials, decorations, pyrotechnics, etc.



ELECTRICAL CONNECTIONS

A qualified electrician should be used for all electrical connections and/or installations.



CAUTIONS

- For added protection, mount the fixture in areas outside walking paths, seating areas, or in areas where unauthorized personnel might reach the fixture.
- Ambient operating temperature range for this fixture is **14° to 113°F. (-10° to 45°C)**
Do not use the fixture under or above this temperature.
- Before mounting the fixture to any surface, make sure the installation area can hold a minimum point load of 10 times the weight of the fixture.
- Fixture installation must always be secured with a secondary safety attachment, such as an appropriate safety cable.
- Never stand directly below the device when mounting, removing or servicing.

MOUNTING POINTS

- Overhead mounting requires extensive experience, including amongst others calculating working load limits, installation material being used, and periodic safety inspection of all installation material and the device. If you lack these qualifications, do not attempt the installation yourself. Improper installation can result in bodily injury.
- Fixture is fully operational in the specific mounting positions as illustrated below.

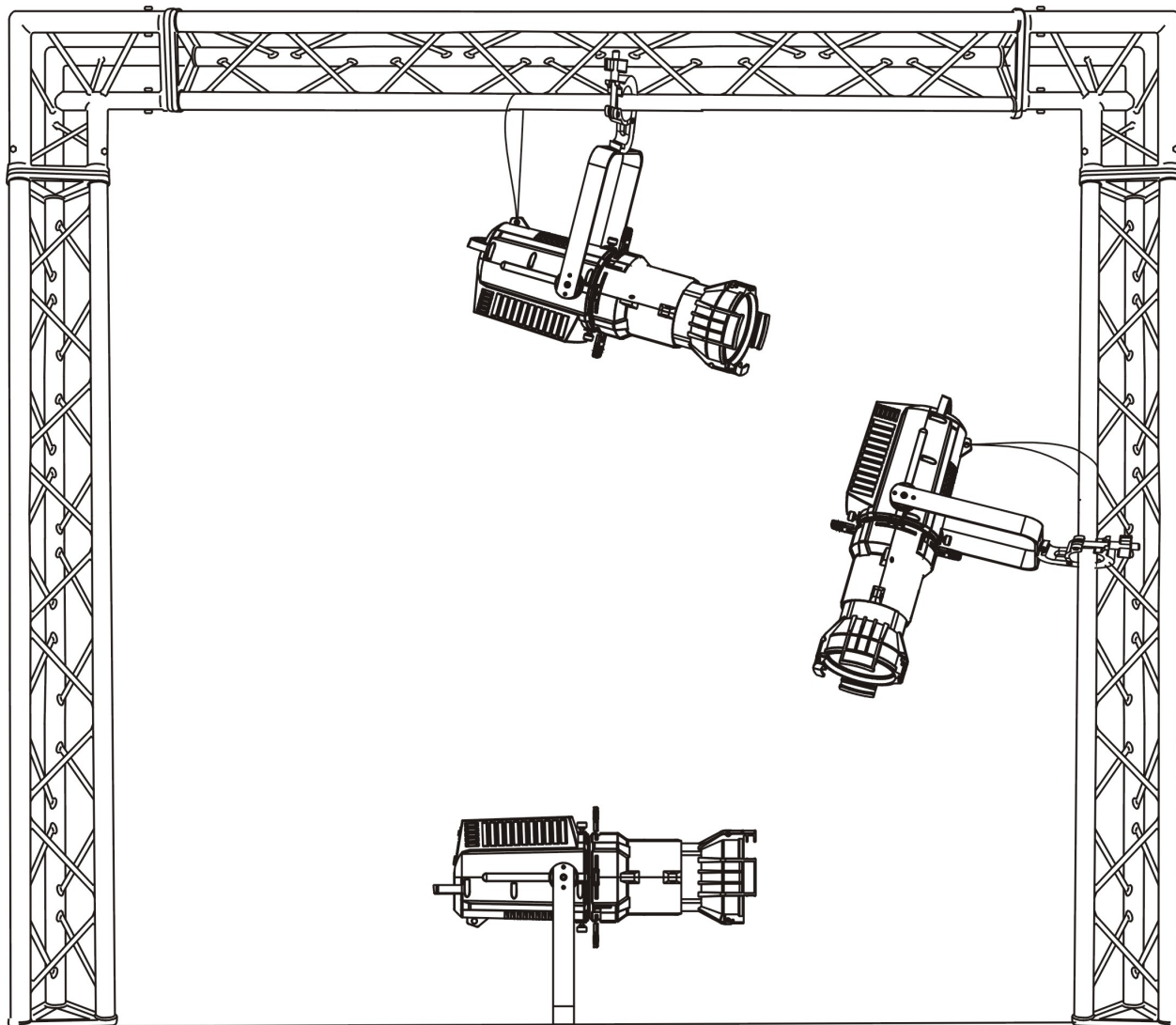

SAFETY CABLE

Always use a Safety Cable whenever installing this fixture in a suspended environment to ensure the fixture will not drop if the clamp fails.

CLAMP MOUNTING

This fixture includes an adjustable mounting yoke and safety cable rigging point attached to the fixture (see the illustration below). When mounting this fixture to truss be sure to secure an appropriately rated clamp (not included) to the yoke using an M10 screw fitted through the center hole of the clamp. Be sure to attach the included **Safety Cable** to the fixture using the safety cable rigging point.

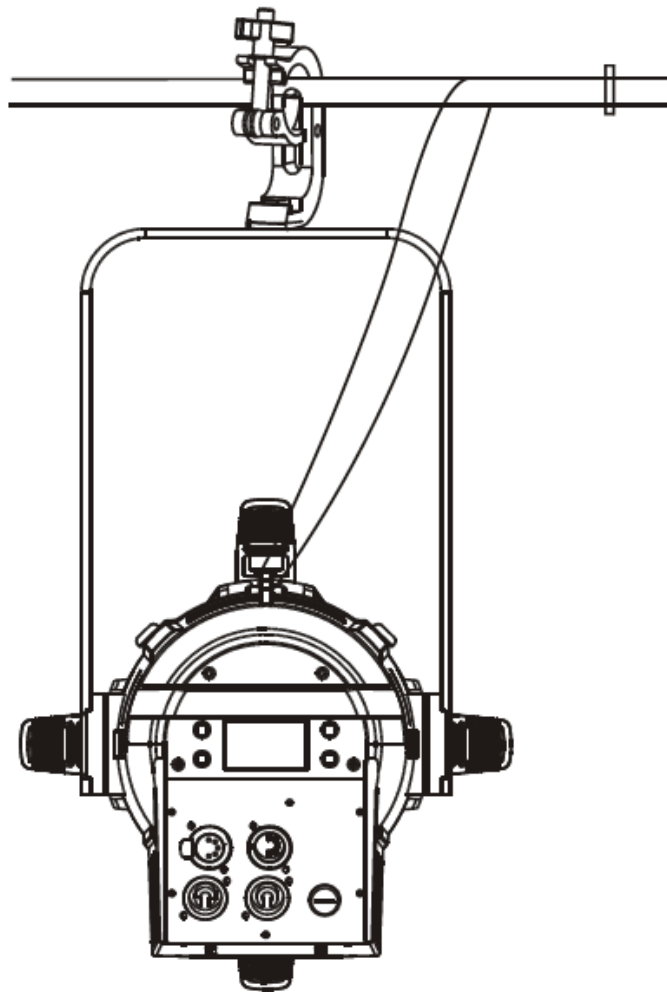

SECURING

Regardless of the rigging option you choose for your fixture always be sure to secure your fixture with a safety cable. The fixture provides a built-in rigging point for a safety cable on the hanging bracket as illustrated above. Be sure to only use the designated rigging point for the safety cable and never secure a safety cable to a carrying handle.

UNDERSTANDING DMX

DMX-512

DMX is short for Digital Multiplex. This is a universal protocol used by most lighting and controller manufactures as a form of communication between intelligent fixtures and controllers. DMX allows all makes and models of different manufactures to be linked together and operate from a single controller. This is possible as long as all the fixtures and the controller are DMX compliant. A DMX controller sends the DMX data instructions to the fixture allowing the user to control the different aspects of an intelligent light. DMX data is sent out as serial data that travels from fixture to fixture via data "IN" and data "OUT" XLR terminals located on the fixtures (most controllers will only have output jacks).

DMX LINKING

To ensure proper DMX data transmission, always use proper DMX cables and a terminator. When using several DMX fixtures try to use the shortest cable path possible. Never split a DMX line with a "Y" style connector. The order in which the fixtures are connected in a DMX line does not influence the DMX addressing. For example; a fixture assigned a starting DMX address of 1 may be placed anywhere in the DMX chain, at the beginning, at the end, or anywhere in the middle. The DMX controller knows to send data assigned to address 1 to that fixture no matter where it is located in the DMX chain. This fixture can be controlled via DMX-512 protocol and the DMX address is set via the control menu.

DATA CABLE (DMX Cable) REQUIREMENTS (For DMX and Master/Slave Operation)

Your fixture and your DMX controller require a standard 3pin or 5pin XLR connector for data input and data output (see figure below). If you are making your own cables, be sure to use two conductor, shielded digital DMX cable rated at 120 ohms; this cable is designed for DMX transmission and may be purchased from your Elation dealer or at most professional lighting retailers. Your cables should be made with a male and female XLR connector on either end of the cable. Also, remember that a DMX line must be daisy chained and cannot be split, unless using an approved DMX splitter such as **Elation's Opto Branch 4™, Opto Branch 8™, or DMX-Branch/4™**.

DMX Output
3-Pin XLR Socket



DMX Input
3-Pin XLR Socket

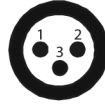

- 1: Ground
- 2: Data (-)
- 3: Data (+)

DMX Output
5-Pin XLR Socket



DMX Input
5-Pin XLR Socket

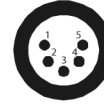

- 1: Ground
- 2: Data (-)
- 3: Data (+)
- 4: Open
- 5: Open



Be sure to follow the above figure when making your own cables. Do not use the ground lug on the XLR connector. Do not connect the cable's shield conductor to the ground lug or allow the shield conductor to come in contact with the XLR outer casing. Grounding the shield could cause a short circuit and erratic behavior.

DMX-512 CONTROLLER CONNECTION

Connect the provided XLR cable to the female XLR output of your controller and the other side to the male XLR input of this fixture. The diagram below illustrates a typical DMX-512 connection when the fixture is in the **19 Channel Mode**. You can chain multiple panels together through serial linking. The cable that should be used is two conductor, shielded DMX cable with XLR input and output connectors. Always be sure daisy chain your in and out data connections, never split or "Y" your DMX connections unless you are using an approved DMX splitter such as **Elation's Opto Branch 4™, Opto Branch 8™, or DMX-Branch/4™**.

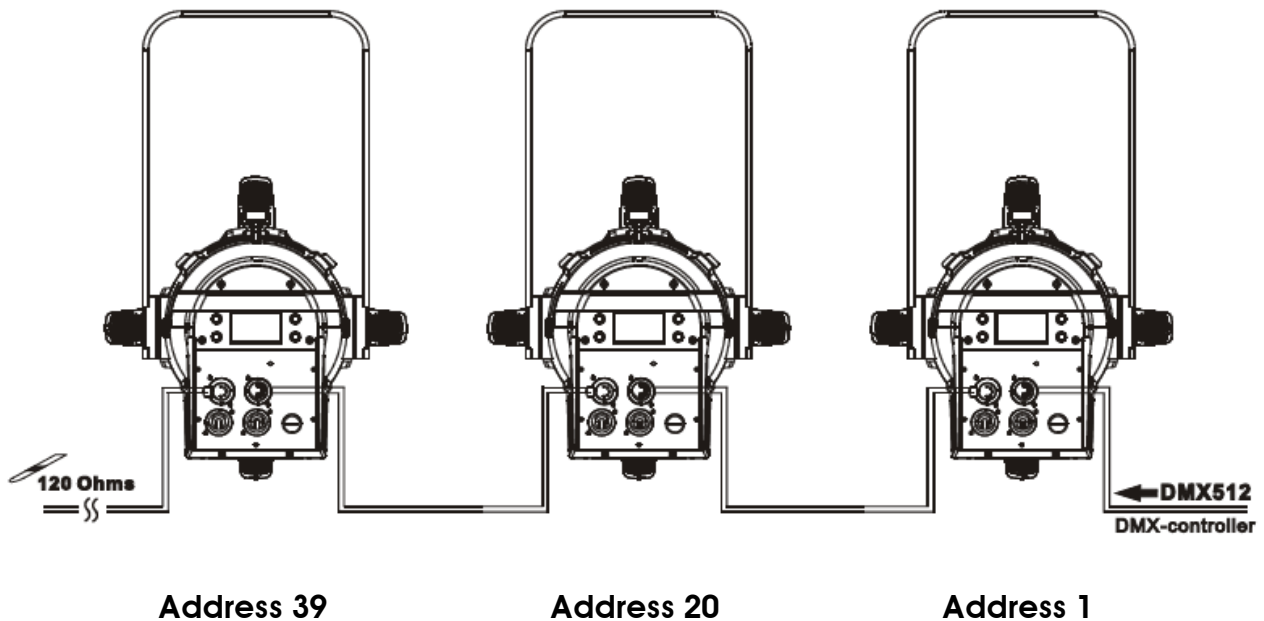

DMX-512 CONNECTION WITH DMX TERMINATOR

A DMX terminator should be used in all DMX lines especially in longer runs. The use of a terminator may avoid erratic behavior in your DMX line. A terminator is a 120 ohm 1/4 watt resistor that is connected between pins 2 and 3 of a male XLR connector (DATA + and DATA -). This fixture is inserted in the female XLR connector of the last fixture in your daisy chain to terminate the line. Using a line terminator will decrease the possibilities of erratic behavior.

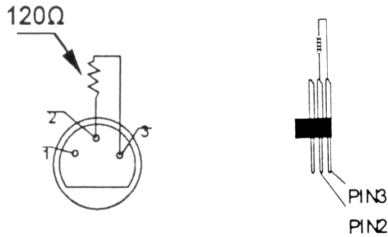

Termination reduces signal errors and avoids signal transmission problems and interference. It is always advisable to connect a DMX terminal, (Resistance 120 Ohm 1/4 W) between PIN 2 (DMX-) and PIN 3 (DMX +) of the last fixture.

5pin XLR DMX CONNECTORS

Some manufactures use 5pin XLR connectors for DATA transmission in place of 3pin. 5pin XLR fixtures may be implemented in a 3pin XLR DMX line. When inserting standard 5pin XLR connectors in to a 3pin line a cable adaptor must be used, these adaptors are readily available at most electric stores. The following chart details a proper cable conversion.

3-Pin XLR to 5-Pin XLR Conversion		
Conductor	3-Pin XLR Female (Out)	5-Pin XLR Male (In)
Ground/Shield	Pin 1	Pin 1
Data Compliment (- signal)	Pin 2	Pin 2
Data True (+ signal)	Pin 3	Pin 3
Not Used		Pin 4 - Do Not Use
Not Used		Pin 5 - Do Not Use

DMX ADDRESSING

All fixtures should be given a DMX starting address when using a DMX controller, so the correct fixture responds to the correct control signal. This digital starting address is the channel number from which the fixture starts to “listen” to the digital control information sent out from the DMX controller. The allocation of this starting DMX address is achieved by setting the correct DMX address on the digital display located on the back of the fixture.

You can set the same starting address for all fixtures or a group of fixtures, or set different address for each individual fixture. Be advised that setting all fixtures to the same DMX address will subsequently control all fixtures in the same fashion, in other words, changing the settings of one channel will affect all the fixtures simultaneously.

If you set each fixture to a different DMX address, each unit will start to “listen” to the channel number you have set, based on the quantity of control channels (DMX channels) of each fixture. That means changing the settings of one channel will only affect the selected fixture.

In the case of this fixture, when in the **19 Channel Mode** you should set the starting DMX address of the first unit to 1, the second unit to 20 (1 + 19), the third unit to 39 (20+ 19), and so on.

Note: During start-up the fixture will automatically detect whether a DMX data signal is being received or not. If DMX data signal is being received, the display will show "**Addr=XXX**" (**XXX** representing the actual DMX address). If the fixture is not receiving a DMX signal the display will flash. If your fixture is connected to a DMX controller and the display is flashing (not receiving a DMX signal), please check the following:

- The 3pin or 5pin XLR input plug (cable with DMX signal from controller) is not connected or is not inserted completely into the DMX input jack of the fixture.
- The DMX controller is switched off or defective.
- The DMX cable or connector is defective.
- A DMX terminator has been inserted into the last fixture in your DMX chain.

FIXTURE MENU

ON-BOARD SYSTEM MENU

The fixture has an easy to navigate system menu. The next section will detail the functions of each command in the system menu.

LCD MENU CONTROL PANEL

The control panel (see image below) located on the fixture allows you to access the main menu and make all necessary adjustments to the fixture. During normal operation, pressing **MODE/ESC** button once will access the fixture's main menu. Once in the main menu you can navigate through the different functions and access the sub-menus with the **UP** and **DOWN** buttons. Once you reach a field that requires adjusting, press the **ENTER** button to activate that field and use the **UP** and **DOWN** buttons to adjust the field. Pressing the **ENTER** button once more will confirm your setting. You may exit the main menu at any time without making any adjustments by pressing the **MODE/ESC** button.



ELATION® COLOUR 5 PROFILE™ SYSTEM MENU					
Specifications are subject to change without any prior written notice.					
MAIN MENU	SUB MENU	OPTIONS / VALUES (Default Settings in BOLD)		DESCRIPTION	
FuncMode	Address	A001 ~ AXXX		DMX Address Setting	
	ValuDisp	= All Ch, Auto, Red, ReF, Gree, Gref...		DMX Value Display	
	SetSlave	Slave1, Slave2, Slave3		Slave Setting	
	AutoProg	Master / Alone		Auto Program	
Info	TimeInfo	Cur Time	XXXX (Hours)	Power On Running Time	
		TotalHrs	XXXX (Hours)	Fixture Running Time	
		Last Hrs	XXXX (Hours)	Fixture Last Times Clear	
		TimePass	Password=XXX	Timer Passcode 038	
	Clr Last	ON/OFF	Clear Fixture Last Time		
	TempInfo	HeadTemp	XXX C° / F°	Temperature in Fixture	
	Soft Ver	= 1.0.1 (or greater)		Software Version	
Persnal	Stat Set	Addr DMX	ON/OFF	Address Via DMX	
		NoDMXSta	CloShut/ Hold /Auto	Auto Run If No DMX	
	Serv Set	Password	Password=XXX		Service Password 050
		RDM PID	XXXXX		RDM PID Code
	Disp Set	Off Time	02~60m OFF		Display Shut Off Time
		Key Lock	ON/OFF		Key Lock
	Temp C/F	Cels/ Fahren		Temperature Switch Between C° / F°	
ResetDef	ON/OFF	Passcode 011	Restore factory settings		
ManCntrl	ManCntrl	Auto =xxx : CIMo = xxx		Adjust Functions Manually	
Mode Set	UserMode	5CH, 6CH, 8CH, 13CH, 19CH		DMX Channel Modes	
Dimming	Dimming	Standar, Stage, TV, Archite, Theatre		Dimming Modes	
EditProg	Sel Prog	ProPart1 = Prog 1~10 (Program 1)		Select Programs To Be Run	
		ProPart2 = Progr1~10 (Program 2)			
		ProPart3 = Prog 1~10 (Program 3)			
	EditProg	Prog 1 : Prog 10	ProgTest = T01SCxxx	Testing Program	
			EdStep 01 = S01SCxxx	Program In Loop	
			EdStep 64 = S64SCxxx	Save and Exit	
EditScen	Scene 001 ~ Scene 250	Cool = Cool=xxx ~ InByOut = Time=xx.xs	Save and Automatically Return Manual Scenes Edit		
RecCntrl	XX~XX	Automatic Scenes Recorder			

FuncMode - Address

Define desired DMX address via the Control Panel.

FuncMode - ValuDisp

Display DMX 512 value of each channel.

FuncMode - SetSlave

Define fixture slave mode (**Slave1, Slave2, Slave3**).

FuncMode - AutoProg

Define fixture mode (**Master or Alone**) for running Auto Programs. Select desired internal programs under "**Select Program**", set the number of steps under "**Edit Program**", and edit individual scenes under "**Edit Scenes**".

Info - TimeInfo - Cur Time

Displays fixture run time from last power ON.

The counter is reset after each time the fixture is powered OFF.

Info - TimeInfo - TotalHrs

Displays fixture total run time.

Info - TimeInfo - Last Hrs

Displays fixture run time for a given period of time (i.e. rental period).

This counter can be reset.

Info - TimeInfo - TimePass

Displays timer passcode. (**038**)

Info - TimeInfo - Clr Last

Clear fixture last run time.

Time can only be cleared after the timer password is entered.

Info - TempInfo - HeadTemp

Displays temperature of the fixture.

Info - Soft Ver

Displays software version of the fixture.

Persnal - Stat Set - Addr DMX

When ON, define the desired DMX address via an external controller.

1. Connect the fixture to the external controller and power ON.
2. Set the DMX value of **Channel 1** on the controller to **(7)**.
3. Set the DMX value of **Channel 2** on the controller to **(7)** or **(8)**.
When set to **(7)**, the DMX address can be set between **(1)** and **(255)**.
When set to **(8)**, the DMX address can be set between **(256)** and **(511)**.
4. Using **Channel 3** on the controller set the desired DMX address of the fixture.

Example 1:

If the desired DMX address is **57**, set **Channel 1** to a value of **(7)**, set **Channel 2** to a value of **(7)**, and then set **Channel 3** to a value of **(57)**.

Example 2:

If the desired DMX address is **420**, set **Channel 1** to a value of **(7)**, set **Channel 2** to a value of **(8)**, and then set **Channel 3** to a value of **(164)**. (256+164=420)

5. After setting **Channel 3** to the desired DMX address value, wait for approximately 20 seconds for the fixture to complete the address reset function.

Define desired DMX address via an external controller.

Persnal - Stat Set - NoDMXSta

Define how fixture operates if NO DMX signal is detected.

Persnal – Serv Set - Password

Service Password - **(050)**



NOTE: The Service Password MUST be entered to access the **RDM PID** menu.

Persnal - Disp Set – Off Time

Define how many minutes before the LCD Menu display will automatically shut OFF.

Persnal - Disp Set – Key Lock

When ON, Control Panel buttons lock automatically after exiting main menu for 15 seconds. To unlock, keep **MODE/ESC** button pressed for 3 seconds.

Persnal – Temp C/F

Define how fixture displays internal temperature (Cels or **Fahren**).

Personal – ResetDef **CAUTION - STORED WHITE BALANCE SETTING WILL BE RESET**

Restore factory settings function (**ON or OFF**). (Password **011**)

ManCntrl – ManCntrl

Adjust functions manually.

Mode Set – UserMode

Select DMX channel modes.

Dimming – Dimming

Select dimming modes (**Standard**, Stage, TV, Archite, Theatre).

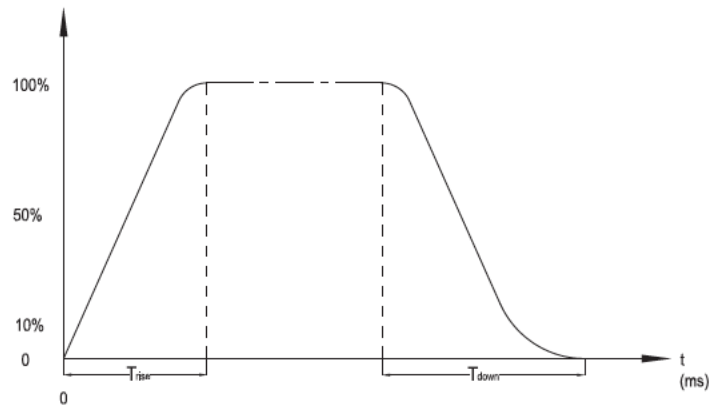

Ramp Effect	0 255 OS (Fade Time)		0 255 1S (Fade Time)	
	T _{rise} (ms)	T _{down} (ms)	T _{rise} (ms)	T _{down} (ms)
Standard	0	0	0	0
Stage	780	1100	1540	1660
TV	1180	1520	1860	1940
Architectural	1380	1730	2040	2120
Theatre	1580	1940	2230	2280

EditProg – Sel Prog

Select one of the (10) user defined internal Auto Programs.

EditProg – EditProg

Edit any of the (10) user defined internal Auto Programs.

EditProg – EditScen

Edit any of the (250) scenes of the internal Auto Programs.

EditProg – RecCntrl

The fixture features an integrated DMX-recorder by which you can transmit the programmed scenes from your DMX-controller to the moving head. Adjust the desired scene numbers via the encoder (from – to). When you call up the scenes at your controller, they will automatically be transmitted to the moving head.

EditProg – RecCntrl – Working With Built In Programs

A Master unit can send up to 3 different data groups to the Slave units, i.e. a Master unit can start 3 different Slave units, which run 3 different programs. The Master unit sends the 3 program parts in a continuous loop.



The Slave unit receives data from the Master unit according to the group which the Slave unit was assigned to. If e.g. a Slave unit is set to “**Slave1**” in the menu “**SetSlave**”, the Master unit sends “**ProPart 1**” to the Slave unit. If set to “**Slave2**”, the Slave unit receives “**ProPart 2**”.

EditProg – RecCntrl – Working With Built-In Program [continued]

To start an Auto Program proceed as follows:

1. Slave Setting

- Select “**FuncMode**”.
- Press **ENTER** to confirm.
- Select “**SetSlave**”.
- Press **ENTER** to confirm.
- Select “**Slave1**”, “**Slave2**” or “**Slave3**”.
- Press **ENTER** to confirm.
- Press **MODE/ESC** in order to return to the main menu.

2. Automatic Program Run

- Select “**FuncMode**”.
- Press **ENTER** to confirm.
- Select “**AutoProg**”.
- Press **ENTER** to confirm.
- Select “**Master**” or “**Alone**”.
- Press **ENTER** to confirm.
- Press **MODE/ESC** in order to return to the main menu.

EditProg – RecCntrl – Working With Built-In Program [continued]

3. Program Selection for Automatic Program Run

- Select **“EditProg”**.
- Press **ENTER** to confirm.
- Select **“Sel Prog ”**.
- Press **ENTER** to confirm.
- Select **“ProPart 1”**, **“ProPart 2”** or **“ProPart 3”**, and select which Slave program is to be sent. Selection **“Part 1”** means, the Slave unit runs the same program as the master units.
- Press **ENTER** to confirm.
- Press **MODE/ESC** in order to return to the main menu.

4. Program Selection for Edit Program

- Select **“EditProg”**.
- Press **ENTER** to confirm.
- Select **“EditProg”**.
- Press **ENTER** to confirm.
- Select the desired program to edit specific scenes into a specific program.
- Press **ENTER** to confirm.
- Press **MODE/ESC** in order to return to the main menu.

5. Automatic Scene Recording

- Select **“EditProg”**.
- Press **ENTER** to confirm.
- Select **“EditScen”**.
- Select desired scene numbers. A maximum of 250 scenes can be programmed.
- Press **ENTER** to confirm.
- Press **MODE/ESC** in order to return to the main menu.

EditProg – RecCtrl – Working With Built-In Program [continued]

Example:

Program 2 includes scenes: 10, 11, 12, & 13

Program 4 includes scenes: 8, 9, & 10

Program 6 includes scenes: 12, 13, 14, & 15

Auto Pro Part 1 is Program 2

Auto Pro Part 2 is Program 3

Auto Pro Part 3 is Program 6

The 3 Slave groups run the Auto Program in certain time segments, as shown in the following picture:

Part 1:

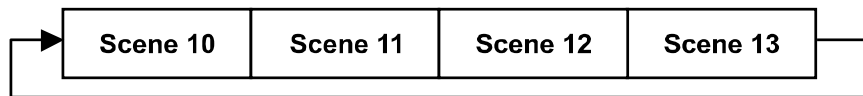

Part 2:

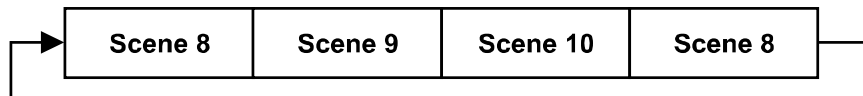

Part 3:

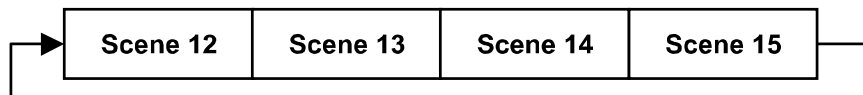

DMX CHANNEL FUNCTIONS AND VALUES

ELATION® COLOUR 5 PROFILE™						
DMX Channel Values / Functions (19 DMX Channels)						
Specifications are subject to change without any prior written notice.						
MODE / CHANNEL					VALUE	FUNCTION
5CH	6CH	8CH	13CH	19CH		
1	1	1	1	1		RED LED
					0-255	RED (0-Black, 255-100% Red)
				2		RED LED FINE
					0-255	RED FINE Adjustment
2	2	2	2	3		GREEN LED
					0-255	GREEN (0-Black, 255-100% Green)
				4		GREEN LED FINE
					0-255	GREEN FINE Adjustment
3	3	3	3	5		BLUE LED
					0-255	BLUE (0-Black, 255-100% Blue)
				6		BLUE LED FINE
					0-255	BLUE FINE Adjustment
4	4	4	4	7		MINT LED
					0-255	MINT (0-Black, 255-100% Mint)
				8		MINT LED FINE
					0-255	MINT FINE Adjustment
5	5	5	5	9		AMBER LED
					0-255	AMBER (0-Black, 255-100% Amber)
				10		AMBER LED FINE
					0-255	AMBER FINE Adjustment
		6	6	11		COLOR TEMPERATURE
					0	NO FUNCTION
					1-255	Color Temperature (1-2,700K. 255-7,200K)
		7	7	12		COLOR MACROS
					0	NO FUNCTION
					1-7	Color Macro 01
					8-15	Color Macro 02
					16-23	Color Macro 03
					24-31	Color Macro 04
					32-39	Color Macro 05
					40-47	Color Macro 06
					48-55	Color Macro 07
					56-63	Color Macro 08
					64-71	Color Macro 09
					72-79	Color Macro 10
					80-87	Color Macro 11
					88-95	Color Macro 12
					96-103	Color Macro 13
					104-111	Color Macro 14
					112-119	Color Macro 15
					120-127	Color Macro 16

ELATION® COLOUR 5 PROFILE™						
DMX Channel Values / Functions (19 DMX Channels)						
Specifications are subject to change without any prior written notice.						
MODE / CHANNEL						
5CH	6CH	8CH	13CH	19CH		
VALUE						
FUNCTION						
		7	7	12	128-135	Color Macro 17
					136-143	Color Macro 18
					144-151	Color Macro 19
					152-159	Color Macro 20
					160-167	Color Macro 21
					168-175	Color Macro 22
					176-183	Color Macro 23
					194-191	Color Macro 24
					192-199	Color Macro 25
					200-207	Color Macro 26
					208-215	Color Macro 27
					216-223	Color Macro 28
					224-231	Color Macro 29
					232-239	Color Macro 30
					240-247	Color Macro 31
					248-255	Color Macro 32
						INTERNAL PROGRAM MACROS
			8	13	0	NO FUNCTION
					1-30	Internal Program 01
					31-60	Internal Program 02
					61-90	Internal Program 03
					91-120	Internal Program 04
					121-150	Internal Program 05
					151-180	Internal Program 06
					181-210	Internal Program 07
					211-255	Internal Program 08
						STROBE
			9	14	0-31	LEDS OFF
					32-63	LEDS ON
					64-95	Strobe Effect SLOW to FAST
					96-127	LEDS ON
					128-159	Pulse Effect In Sequences
					160-191	LEDS ON
					192-223	Random Strobe Effect SLOW to FAST
					224-255	LEDS ON
	6	8	10	15		DIMMER INTENSITY
					0-255	Intensity 0 to 100%
				16		DIMMER FINE
					0-255	FINE Intensity 0 to 100%
						DIMMING CURVES
			11	17	0-41	STANDARD
					42-84	STAGE
					85-127	TV
					128-170	ARCHITECTURAL
					171-213	THEATRE
					214-255	Default to Unit Dimming Curve Setting
			12	18		COLOR ENABLE
					0-189	NO Function
					190-255	Enable (Turn ON) EDIT WHITE BALANCE Mode
			13	19		COLOR MODE
					0-189	NO Function
					190-254	EDIT (Set) a New WHITE BALANCE
					255	STORE (Save) a New WHITE BALANCE

CLEANING AND MAINTENANCE



C A U T I O N

Disconnect power before cleaning or maintenance.

CLEANING

Frequent cleaning is recommended to insure proper function, optimized light output, and an extended life. The frequency of cleaning depends on the environment in which the fixture operates: damp, smoky or particularly dirty environments can cause greater accumulation of dirt on the fixture's optics.

- Clean the external lens surface at least every 20 days with a soft cloth to avoid dirt/debris accumulation.
- Never use alcohol, solvents, or ammonia based cleaners.

MAINTENANCE

Regular inspections are recommended to insure proper function and extended life. There are no user serviceable parts inside this fixture, please refer all other service issues to an authorized Elation service technician. Should you need any spare parts, please order genuine parts from your local Elation dealer.

Please refer to the following points during routine inspections:

- A detailed electric check by an approved electrical engineer every three months, to make sure the circuit contacts are in good condition and prevent overheating.
- Be sure all screws and fasteners are securely tightened at all times. Loose screws may fall out during normal operation resulting in damage or injury as larger parts could fall.
- Check for any deformations on the housing, color lenses, rigging hardware and rigging points (ceiling, suspension, trussing). Deformations in the housing could allow for dust to enter into the fixture. Damaged rigging points or unsecured rigging could cause the fixture to fall and seriously injure a person(s).
- Electric power supply cables must not show any damage, material fatigue or sediments. Never remove the ground prong from the power cable.

TECHNICAL SPECIFICATIONS

FEATURES

High CRI >94, 4,100 Total Lumens*
Interchangeable Lens Options** (19°, 26°, 36°, 50°)
(4) Blade Manual Framing Shutters
Flicker Free Operation for TV and FILM
(*with 26° lens) (**sold separately)

SOURCE

180W RGBAM (Red, Green, Blue, Amber, Mint) LED Engine

EFFECTS

Electronic Strobe and Dimming
Variable Dimming Curve Modes

GOBOS

Supports "B" Size Metal, HT Transparency Gobos*
*Gobos and Holder not included.

CONTROL / CONNECTIONS

5 DMX Channel Modes (5 / 6 / 8 / 13 / 19)
4 Button Control Panel
LED Menu Display
5pin DMX In/Out
powerCON In/Out

SIZE / WEIGHT

Length: 24.3" (618mm)
Width: 12.2" (310mm)
Vertical Height: 15.7" (398mm)
Weight: 21.0 lbs. (9.5 kg)

ELECTRICAL / THERMAL

AC 100-240V - 50/60Hz
225W Max Power Consumption
14° to 113°F (-10° to 45°C)

APPROVALS / RATINGS

CE | cETLus | IP20



Intertek
4010832

Please Note: Specifications and improvements in the design of this unit and this manual are subject to change without any prior written notice.

PHOTOMETRIC DATA

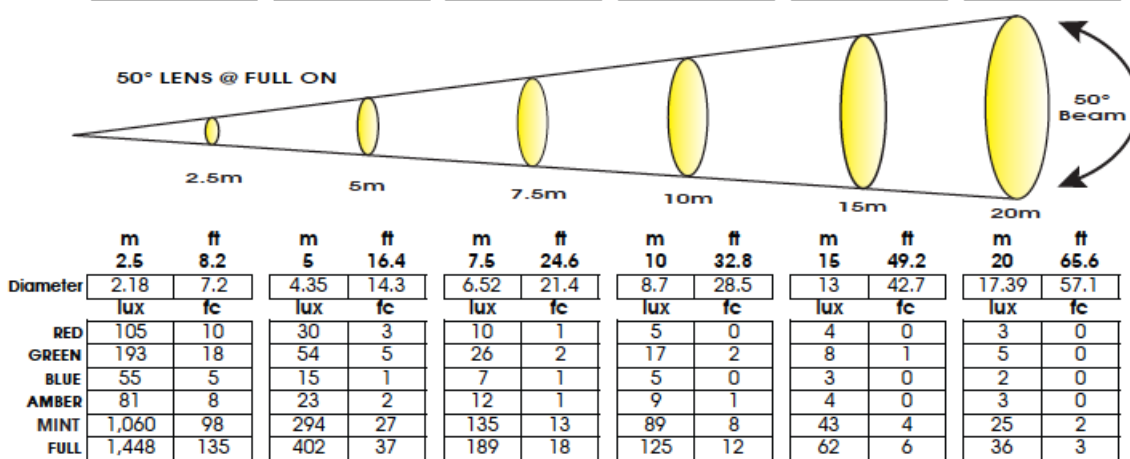
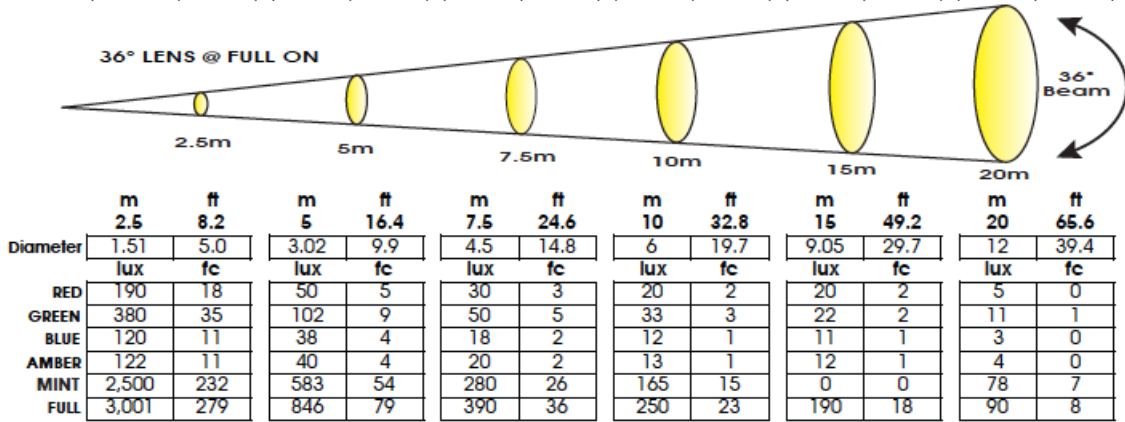
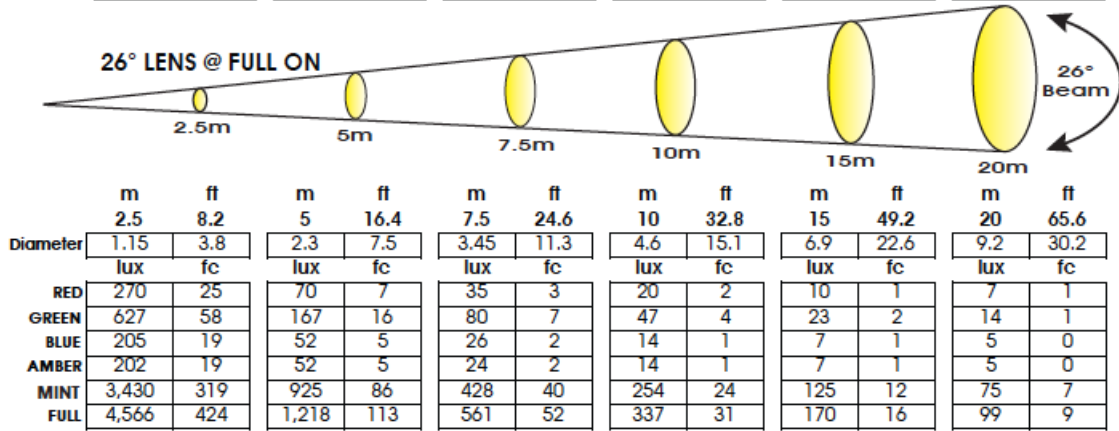
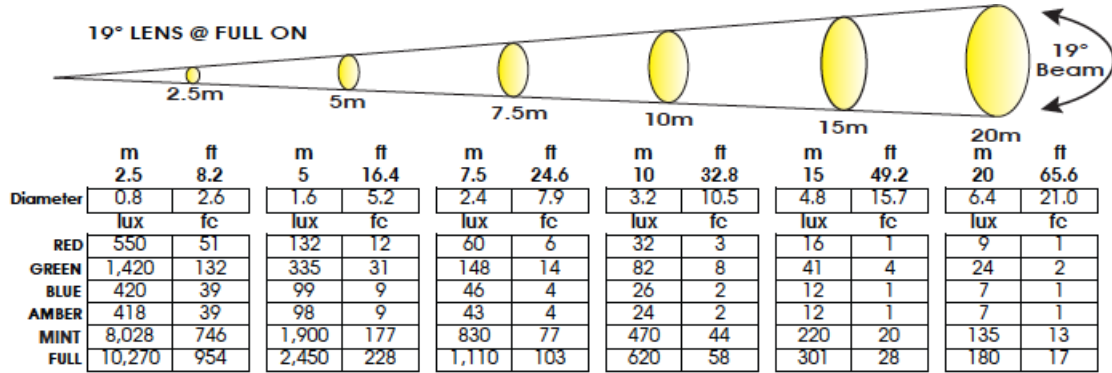

Please Note: Specifications and improvements in the design of this unit and this manual are subject to change without any prior written notice.

DIMENSIONAL DRAWINGS

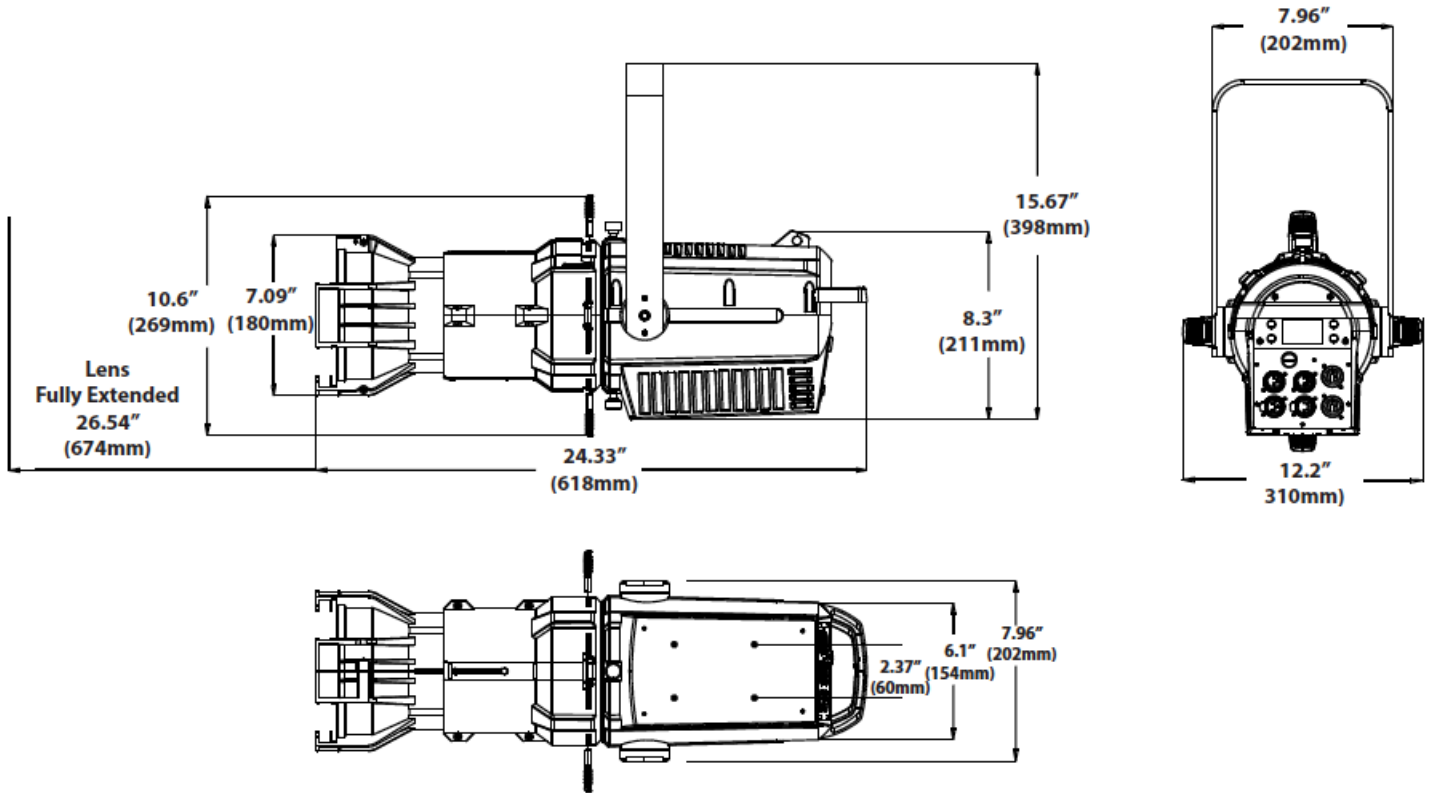

Please Note: Specifications and improvements in the design of this unit and this manual are subject to change without any prior written notice.

OPTIONAL ACCESSORIES

ORDER CODE	ITEM
TRIGGER CLAMP	Heavy Duty Wrap Around Hook Style Clamp
PHD019	Profile High Definition Lens 19°
PHD126	Profile High Definition Lens 26°
PHD236	Profile High Definition Lens 36°
PHD350	Profile High Definition Lens 50°
PLC3	3' (1m) powerCON PRO Link Cable
AC5PDMX5PRO	5 ft. (1.5m) 5pin PRO DMX Cable
	Additional Cable Lengths Available

