

# ARTISTE DAVINCI



The **Artiste Davinci™** features a new 270W Cool White LED engine with advanced optics delivering over 12,000 total lumens, ultra wide 6° to 48° zoom, full CMY color mixing and linear CTO color correction, 7 dichroic colors including CTB and Violet, 6 rotating glass and 9 static-stamped metal interchangeable gobos, 3-facet and linear rotating prisms, frost filter, full 360° bi-directional animation wheel, motorized iris, focus, and auto-focus, variable dimming curve modes, high speed electronic shutter and strobe, hibernation mode, DMX, RDM (Remote Device Management), Art-NET, and sACN protocol support, Elation's E-FLY™ internal wireless DMX transceiver, 5pin XLR, RJ45 etherCON, and powerCON TRUE1 in/out connections, full color 180° reversible menu display with 6 button touch control panel, battery backup for display power, adjustable LED refresh rate and gamma brightness for flicker free operation for TV and FILM, and a multi-voltage universal auto switching power supply (100-240v).

## FEATURES

**270W Cool White 12,000 Total Lumen LED Spot Luminaire**

**6° to 48° Motorized Zoom**

**Full CMY Color Mixing and Linear CTO Color Correction**

**7 Dichroic Colors including CTB and Violet**

**6 Rotating and 9 Static-Stamped Interchangeable Gobos**

**3-Facet and Linear Rotating Prisms and Frost Filter**

**Full 360° Bi-Directional Animation Wheel**

**High Speed Electronic Shutter and Strobe**

**Motorized Iris, Focus and Variable Dimming Curve Modes**

**DMX, RDM, Art-NET, and sACN Support**

**Elation's E-FLY™ Internal Wireless DMX Transceiver**

**Low Heat, Quiet Operation, Hibernation Mode**

**Adjustable Refresh Rate Frequency and GAMMA**

**Flicker Free Operation for TV and FILM**



Specifications are subject to change without notice ©Elation Professional 03/13/19

Elation Professional USA | 6122 S. Eastern Ave. | Los Angeles, CA. 90040  
323-582-3322 | 323-832-9142 fax | www.elationlighting.com | info@elationlighting.com

Elation Professional B.V. | Junostraat 2 | 6468 EW Kerkrade, The Netherlands  
+31 45 546 85 66 | +31 45 546 85 96 fax | www.elationlighting.eu | info@elationlighting.eu

**SPECIFICATIONS**

**SOURCE**

270W Cool White 12,000 Total Lumen LED Engine  
50,000 Hour Average LED Life\*

\*LED Life may vary depending on several factors including but not limited to: Environmental Conditions, Power/Voltage, Usage Patterns (On-Off Cycling), Control and Dimming.

**PHOTOMETRIC DATA**

23,560 LUX 2,189 FC @16.4' (5m) (6° Full ON)  
1,049 LUX 97 FC @16.4' (5m) (48° Full ON)

**EFFECTS**

6° - 48° Motorized Zoom  
3-Facet and Linear Rotating Prisms and Prism Macros  
Full 360° Bi-Directional Rotating Animation Wheel  
Frost Filter Hybrid Wash Effect  
Motorized Zoom, Iris, Focus, and Auto-Focus  
High Speed Electronic Shutter and Strobe  
16-Bit Variable Dimming Curve Modes  
Adjustable LED Refresh Rate and Gamma Brightness

**COLOR**

7 Dichroic Colors including CTB and Violet  
Full CMY Color Mixing + Linear CTO Color Correction

**GOBOS**

(6) Interchangeable Rotating / Indexing Glass Gobos  
(9) Interchangeable Static-Stamped Metal Gobos

**CONTROL / CONNECTIONS**

(3) DMX Channel Modes (40 total channels)  
Adjustable Refresh Rate (900-25,000 (Hz)  
Adjustable Gamma Brightness (2.0, 2.2, 2.4, 2.8)  
6 Button Touch Control Panel  
Full Color 180° Reversible LCD Menu Display  
8 / 16 Bit Resolution Adjustable Movement  
DMX, RDM, Art-NET and sACN Protocol Support  
Elation E-FLY™ Internal Wireless DMX Transceiver  
5pin DMX, RJ45 Ethernet In/Out (Art-NET, sACN)  
powerCON TRUE1 Power In/Out

**SIZE / WEIGHT**

Length: 16.4" (416mm)  
Width: 11.2" (284mm)  
Vertical Height: 25.4" (645mm)  
Weight: 56.0 lbs. (25.4kg)

**ELECTRICAL / THERMAL**

AC 100-240V - 50/60Hz  
470W Max Power Consumption  
14°F to 113°F (-10°C to 45°C)

**APPROVALS / RATINGS**



IP20



**ORDERING INFORMATION**

EAD963	ARTISTE DAVINCI FIL™
TRIGGER CLAMP	Heavy Duty Wrap Around Hook Style Clamp
EFL001	E-FLY™ Wireless DMX Transceiver
AC5PDMX5PRO	5 ft. (1.5m) 5pin PRO DMX Cable
NEU088	3 ft. (1m) powerCON TRUE1 Power Link Cable
CAT6PRO5	5 ft. (1.5m) CAT6 EtherCON Cable
Additional cable lengths available	

**PHOTOMETRIC DATA**

**MIN ZOOM - 6° Beam Diameter (full on)**

5 m	16.4 ft	10 m	32.8 ft	15 m	49.2 ft
0.55	1.8	1.11	3.6	1.67	5.5
lux	fc	lux	fc	lux	fc
23,560	2,189	5,910	549	2,668	248

**MAX ZOOM - 48° Beam Diameter (full on)**

5 m	16.4 ft	10 m	32.8 ft	15 m	49.2 ft
4.4	14.4	8.8	28.9	13.2	43.3
lux	fc	lux	fc	lux	fc
1,049	97	307	29	147	14

**COLORS AND GOBOS**

**COLOR FLAGS**



**COLOR WHEEL**



**INTERCHANGEABLE-ROTATING GOBO WHEEL 1 - OD: Ø29.8mm\*\* ID: Ø20.0mm**

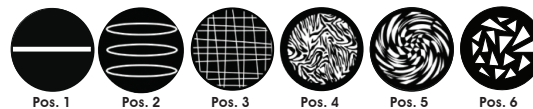

**INTERCHANGEABLE STATIC-FIXED GOBO WHEEL 2 - OD: Ø25.8mm\*\* ID: Ø22.0mm**



**\*\*IMPORTANT NOTICE REGARDING GOBO DIMENSIONS AND CUSTOM GOBOS**

OD = Outside Diameter | ID = Image Diameter  
Due to varying manufacturing processes, it is highly recommended to provide a gobo and holder sample from the fixture to 3rd party custom gobo vendors for accurate sizing.

**DIMENSIONAL DIAGRAMS**

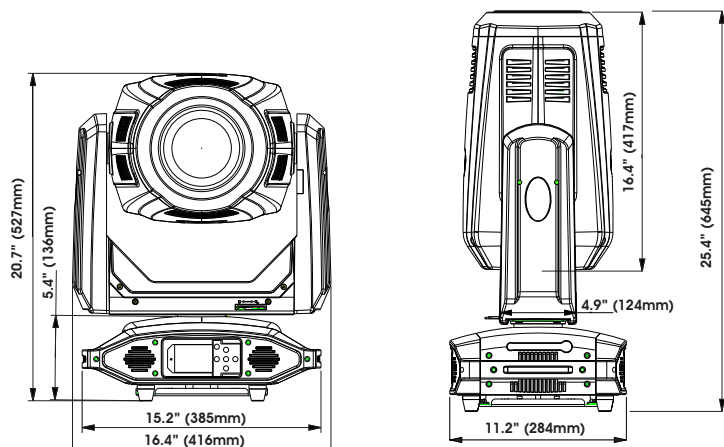

Specifications are subject to change without notice ©Elation Professional 03/13/19

Elation Professional USA | 6122 S. Eastern Ave. | Los Angeles, CA. 90040  
323-582-3322 | 323-832-9142 fax | www.elationlighting.com | info@elationlighting.com

Elation Professional B.V. | Junostraat 2 | 6468 EW Kerkrade, The Netherlands  
+31 45 546 85 66 | +31 45 546 85 96 fax | www.elationlighting.eu | info@elationlighting.eu

FOAM IN LAY DIMENSIONAL DRAWINGS

