

blizzard™



Blizzard Lighting, LLC
www.blizzardlighting.com
Waukesha, WI USA
Copyright (c) 2015

TABLE OF CONTENTS

| | |
|-------------------------------------------------------------|-----------|
| PixlStik™ | 1 |
| 1. Getting Started | 3 |
| What's In The Box? | 3 |
| Getting It Out Of The Box | 3 |
| Powering Up! | 3 |
| Getting A Hold Of Us | 3 |
| Safety Instructions (Don't Stick Your Hand In The Toaster!) | 4 |
| 2. Meet PixlStik™ | 5 |
| Main Features | 5 |
| DMX Quick Reference | 5 |
| The PixlStik™ Pin-up Picture | 6 |
| Rear Connections | 6 |
| 3. Setup | 7 |
| Clear/Frost Filter Installation | 7 |
| Mounting Guidelines | 7 |
| Mounting Instructions | 8 |
| Power/Signal Connection Procedure | 8 |
| Addressing Of Each Output When Using Art-Net™ | 9 |
| 4. Appendix | 10 |
| A Quick DMX Lesson | 10 |
| Art-net™ Protocol | 10 |
| ArKaos Kling-Net™ | 10 |
| Keeping Your PixlStik™ As Good As New | 11 |
| Returns (Gasp!) | 11 |
| Shipping Issues | 11 |
| Tech Specs | 12 |
| Dimensional Drawings | 13 |

1. GETTING STARTED

What's In The Box?

- 1 x PixlStik™ Professional LED Fixture
- 1 x Clear Filter
- 1 x Cat5e Ethernet Cable
- This Lovely User Manual

Getting It Out Of The Box

Congratulations on your purchase of the PixlStik™, the totally cool LED strip light that is specifically designed to bring an exciting new look to your light show, and nightmares to your old grammar school teacher! So, now that you've got your PixlStik™ (or hopefully, PixlStiks!), you should carefully unpack the box and check the contents to ensure that all parts are present and in good condition. If anything looks as if it has been damaged in transit, notify the shipper immediately and keep the packing material for inspection. Again, please save the carton and all packing materials. If a fixture must be returned to the factory, it is important that the fixture be returned in the original factory box and packing.

Getting A Hold Of Us

If something is wrong, please just visit our website at www.blizzardlighting.com and open a support ticket. We'll be happy to help, honest.

Blizzard Lighting
N16 W23390 Stoneridge Dr. Suite E
Waukesha, WI 53188 USA
www.blizzardlighting.com
414-395-8365

Disclaimer: The information and specifications contained in this document are subject to change without notice. Blizzard Lighting™ assumes no responsibility or liability for any errors or omissions that may appear in this user manual. Blizzard Lighting™ reserves the right to update the existing document or to create a new document to correct any errors or omissions at any time. You can download the latest version of this document from www.blizzardlighting.com.

| Author: | Date: | Last Edited: | Date: |
|-----------|----------|--------------|----------|
| J. Thomas | 9/7/2015 | J. Thomas | 9/7/2015 |

SAFETY INSTRUCTIONS



Please read these instructions carefully. They include important information about the installation, usage and maintenance of this product.

- Please keep this User Guide for future use. If you sell the unit to someone else, be sure that they also receive this User Guide.
- ALWAYS make sure that you are connecting to the proper voltage to the driver, and that the line voltage you are connecting to is not higher than that stated on the decal or rear panel of the fixture.
- This product is intended for indoor use only.
- To prevent risk of fire or shock, do not expose fixture to rain or moisture.
- Make sure there are no flammable materials close to the unit while operating.
- ALWAYS secure fixture using a safety chain. NEVER carry the fixture by its cord. Use its carrying handle.
- DO NOT operate at ambient temperatures higher than 104°F (40°C).
- In the event of a serious operating problem, stop using the unit immediately. NEVER try to repair the unit by yourself. Repairs carried out by unskilled people can lead to damage or malfunction. Please contact the nearest authorized technical assistance center. Always use the same type spare parts.
- NEVER connect the device to a dimmer pack.
- Avoid direct eye exposure to the light source while it is on.

Caution! There are no user serviceable parts inside the unit. Do not open the housing or attempt any repairs yourself. In the unlikely event your unit may require service, please visit www.blizzardlighting.com/tickets to request support via our online support ticket system.

2. MEET THE PIXLSTIK™ LED STRIP

PixlStik™ is a pixel mapping, one-meter strip that sets up in minutes with minimal technical knowledge. Each unit houses 40 tri-colored RGB SMD 5050 LEDs, has a pixel pitch of 25 millimeters and 120-degree viewing angle, plus each unit comes with a changeable clear and frosted lens filter.

The mechanics of the PixlStik™ have been well thought out and designed to allow tons of mounting flexibility through its sliding hardware on the back for truss applications, as well as on the side for multiple vertical linking.

The external control unit of the PixlStik™ is called PixlKontrol™, and is compatible with Art-Net, Kling-Net, DMX protocol, and it runs both the signal and power over a RJ45 In/Out connections that provide great stability and connection while daisy chaining up to 4 PixlStik™ fixtures per each of the PixlKontrol's 4 power + data outputs for a total of up to 16 fixtures per unit.

MAIN FEATURES

- 40* SMD5050 RGB/FC high-efficiency LEDs
- Luminous flux: frosted lens = 828 NIT, transparent lens = 1174 NIT
- Individual pixel control
- Viewing angle: 120°
- Pixel pitch: 25 mm
- Color synthesis: RGB/Full Color mixing (>16 million colors)
- Flicker-free constant-current 600hz LED driver
- LEDs average life span: >50,000 hours

ADDITIONAL FEATURES

- Control protocols: Art-Net, Kling-Net, DMX
- Channels Art-Net: 120 per fixture
- Channels DMX:8
- Sturdy aluminum profile
- Internal Protection: IP20
- Sliding bracket for vertical hardware for connection of more units
- Frosted and transparent filter are included
- Power unit: DC24V
- IN/OUT power and signal through connections RJ45 (Max 16 units per PixlKontrol™ driver)

Figure 1: The PixlStik™ Pin-Up Picture

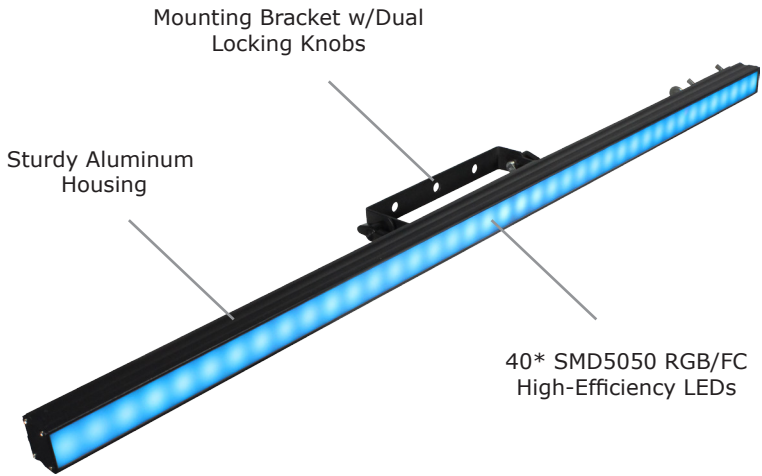
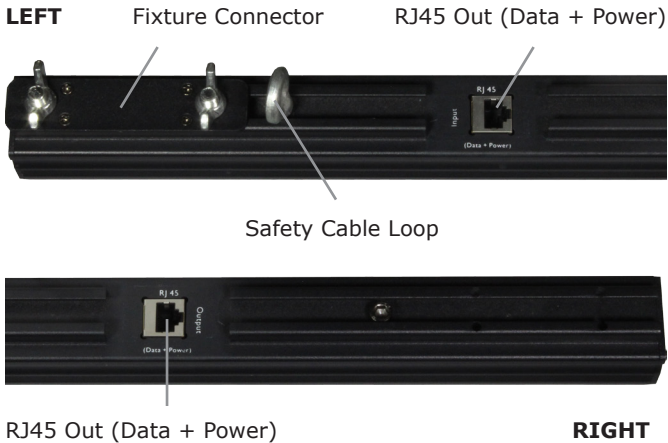

Figure 2: The Rear Connections



3. SETUP

Clear/Frost Filter Installation:

The PixlStik™ includes a frost filter already installed. Follow the procedure below to install the clear filter.

1. Locate the end cap of the product.
2. Remove the 4 screws from the end cap of the product.
3. Slide out and remove the installed filter.
4. Slide in the desired filter.
5. Re-install the end cap.

**Be sure to install the frost filter with the shiny side facing toward the LEDs.*



Mounting Guidelines

We recommend the following guidelines when mounting:

- While deciding on a mounting location, be sure there is convenient access to your fixture(s) for maintenance and programming.
- Make sure the structure that you are mounting this product to can support its weight.
- When mounting overhead, always use a safety cable and mount the unit to a secure rigging point.
- When rigging this fixture onto a truss, be sure to use mounting clamps with appropriate weight capacity ratings.
- Do not use tools to loosen or tighten the hanging bracket knobs when adjusting the angle of the fixture. Tighten them manually. Using tools could damage the knobs.

Mounting Instructions

1. Attach the clamp to the mounting bracket.
2. Attach the clamp to the desired structure or surface.
3. Attach a safety cable to the product's safety cable loop.

Series Attachment Instructions

PixlStik™ fixtures can be attached in an end-to-end formation to create a strip up to 4 meters long (4 fixtures) from just one rigging point.

CAUTION! - Do not connect more than a total of 4 fixtures in a row when hanging vertically.

1. Loosen the wing nuts on the 1st fixture's connector bracket.
2. Slide the connector bracket out till it stops at the midway point off of the end of the 1st fixture, and tighten the 1st wing nut to secure the connector bracket in place.
3. Slide the 2nd fixture onto the connecting bracket and tighten the 2nd wing nut, then attach the safety cable.
4. Repeat the process to attach more fixtures.

Power/Signal Connection Procedure

PixlStik™ fixtures use an RJ45 connection to link all ports. Each strip can be linked from end-to-end never exceeding a total of 4 fixtures for each daisy chain. The following diagram illustrates how to configure the data connections.

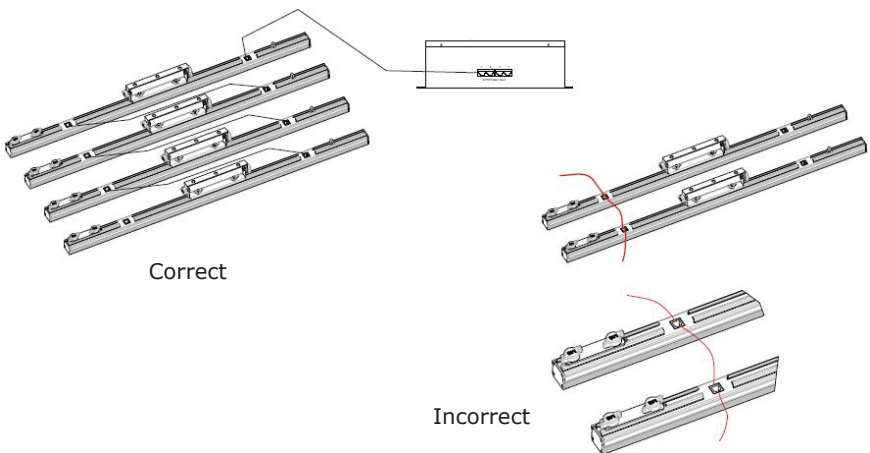

NOTE - When hanging multiple end-to-end connected fixtures vertically, be sure to secure each fixture together with safety cables. First, attach a safety cable from one fixture's hanging bracket to a secure rigging point. Then, secure each fixture together by attaching a safety cable from each fixture's mounting bracket to its neighboring fixture's safety cable loop.

Addressing Of Each Output When Using Art-Net™

The PixlKontrol™ uses an RJ45 data connection to link all data ports. You can connect up to 4 daisy chained PixlStik™ fixtures per output on the PixlKontrol™. The following diagram illustrates how to assemble the data connections, and each fixtures starting DMX address per universe using Art-Net:

- Fixture 1: 001 <--> 120
- Fixture 2: 121 <--> 240
- Fixture 3: 241 <--> 360
- Fixture 4: 361 <--> 480

Make sure each total length of the connecting network cables (RJ45) does not exceed 10-meters (32.8 feet).

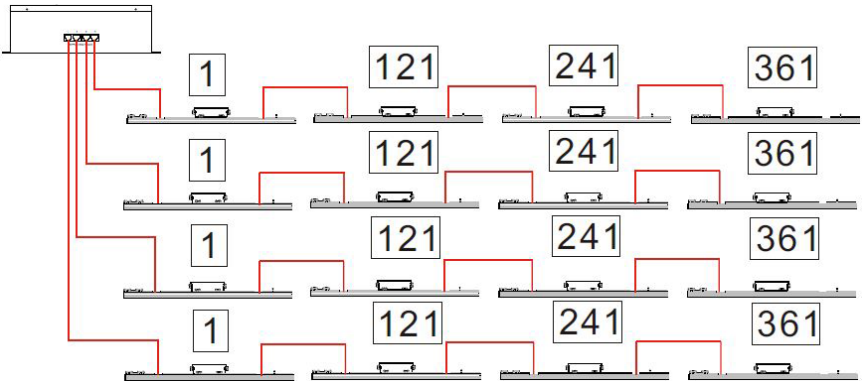

4. APPENDIX

A Quick Lesson On DMX

DMX (aka DMX-512) was created in 1986 by the United States Institute for Theatre Technology (USITT) as a standardized method for connecting lighting consoles to lighting dimmer modules. It was revised in 1990 and again in 2000 to allow more flexibility. The Entertainment Services and Technology Association (ESTA) has since assumed control over the DMX512 standard. It has also been approved and recognized for ANSI standard classification.

DMX provides up to 512 control "channels" per data link. Each of these channels was originally intended to control lamp dimmer levels. You can think of it as 512 faders on a lighting console, connected to 512 light bulbs. Each slider's position is sent over the data link as an 8-bit number having a value between 0 and 255. The value 0 corresponds to the light bulb being completely off while 255 corresponds to the light bulb being fully on.

DMX is connected using a daisy-chain configuration where the source connects to the input of the first device, the output of the first device connects to the input of the next device, and so on. The standard allows for up to 32 devices on a single DMX link.

Each receiving device typically has a means for setting the "starting channel number" that it will respond to. For example, if two 6-channel fixtures are used, the first fixture might be set to start at channel 1 so it would respond to DMX channels 1 through 6, and the next fixture would be set to start at channel 7 so it would respond to channels 7 through 12.

The greatest strength of the DMX communications protocol is that it is very simple and robust. It involves transmitting a reset condition (indicating the start of a new "packet"), a start code, and up to 512 bytes of data. Data packets are transmitted continuously. As soon as one packet is finished, another can begin with no delay if desired (usually another follows within 1 ms). If nothing is changing (i.e. no lamp levels change) the same data will be sent out over and over again. This is a great feature of DMX -- if for some reason the data is not interpreted the first time around, it will be re-sent shortly.

Not all 512 channels need to be output per packet, and in fact, it is very uncommon to find all 512 used. The fewer channels are used, the higher the "refresh" rate. It is possible to get DMX refreshes at around 1000 times per second if only 24 channels are being transmitted. If all 512 channels are being transmitted, the refresh rate is around 44 times per second.

Art-net™ Protocol

Art-Net is a protocol for transmitting the lighting control protocol DMX512-A (with RDM) over the User Datagram Protocol of the Internet Protocol suite. The protocol was developed by Wayne Howell and his company, Artistic Licence Engineering (UK) Ltd, is open for implementation with attribution but without charge, and made available as a software development kit for convenience. It is typically implemented as lighting-control nodes in embedded controllers, driven from a lighting desk or similar software operating as a server. Art-Net compatible products are made available by dozens of companies.

ArKaos Kling-Net™

ArKaos has designed the Kling-Net protocol to allow the distribution of real-time video data to remote display devices, such as LEDs or LED panels, over Ethernet.

Many first time users are afraid of using LED lighting because of the complexity of networking and control issues. Using and networking LED lighting has required a high level of technical knowledge which has been a deterrent for many.

ArKaos wanted to remove all this complexity and replace it with an easy protocol which automatically takes care of the magic numbers for the user!

The purpose of Kling-Net is:

- To allow the automatic configuration and connection of display devices to a computer
- To add some "intelligence" into display devices, which enables auto configuration
- To ensure a perfect time synchronization of multiple display devices
- To avoid using expensive hardware video converters to send video to display devices
- To allow the creation of an heterogeneous network of display devices from different manufacturers, which can all be controlled from one computer

Keeping Your PixlStik™ As Good As New

The fixture you've received is a rugged, tough piece of pro lighting equipment, and as long as you take care of it, it will take care of you. That said, like anything, you'll need to take care of it if you want it to operate as designed. You should absolutely keep the fixture clean, especially if you are using it in an environment with a lot of dust, fog, haze, wild animals, wild teenagers or spilled drinks.

Cleaning the optics routinely with a suitable glass cleaner will greatly improve the quality of light output. Keeping the fans free of dust and debris will keep the fixture running cool and prevent damage from overheating.

In transit, keep the fixtures in cases. You wouldn't throw a prized guitar, drumset, or other piece of expensive gear into a gear trailer without a case, and similarly, you shouldn't even think about doing it with your shiny new light fixtures.

Common sense and taking care of your fixtures will be the single biggest thing you can do to keep them running at peak performance and let you worry about designing a great light show, putting on a great concert, or maximizing your client's satisfaction and "wow factor." That's what it's all about, after all!

Returns (Gasp!)

We've taken a lot of precautions to make sure you never even have to worry about sending a defective unit back, or sending a unit in for service. But, like any complex piece of equipment designed and built by humans, once in a while, something doesn't go as planned. If you find yourself with a fixture that isn't behaving like a good little fixture should, you'll need to obtain a Return Authorization (RA).

Don't worry, this is easy. Just go to our website and open a support ticket at www.blizzardlighting.com/support, and we'll issue you an RA. Then, you'll need to send the unit to us using a trackable, pre-paid freight method. We suggest using USPS Priority or UPS. Make sure you carefully pack the fixture for transit, and whenever possible, use the original box & packing for shipping.

When returning your fixture for service, be sure to include the following:

- 1.) Your contact information (Name, Address, Phone Number, Email address).
- 2.) The RA# issued to you
- 3.) A brief description of the problem/symptoms.

We will, at our discretion, repair or replace the fixture. Please remember that any shipping damage which occurs in transit to us is the customer's responsibility, so pack it well!

Shipping Issues

Damage incurred in shipping is the responsibility of the shipper, and must be reported to the carrier immediately upon receipt of the items. Claims must be made within seven (7) days of receipt.

Tech Specs!

| Weight & Dimensions | | |
|-------------------------------------------------------------------------------|------------------------------------------------|----------------|
| Width | 39.38 inches (1000 mm) | |
| Depth | 1.4 inches (36.5 mm) | |
| Height | 3.7 inches (95 mm) | |
| Weight | 4.4 lb (2 kg) | |
| Power | | |
| Operating Voltage | 100-240VAC, 50-60 Hertz | |
| Power Consumption | 20W, .11A | |
| Light Source | | |
| LED | 40* (tri-color) SMD 5050 LEDs, 50,000 hours | |
| Optical | | |
| Viewing Angle | 120 degree | |
| Luminance | Clear Filter | Frosted Filter |
| | 1,174 NITS | 828 NITS |
| Pixels | 40 x 1 | |
| Pixel Pitch | 25mm | |
| PWM Frequency | Flicker-free constant-current 600hz LED driver | |
| Thermal | | |
| Max. Operating Temp. | 104 degrees F (40 degrees C) ambient | |
| Control | | |
| Protocol | Art-Net™, Kling-Net, USITT DMX-512 | |
| DMX Channels | 8-Channels | |
| Artnet Channels | 120-Channels | |
| Input/Output | RJ45 in/out connections | |
| Linking | Up to 16 in-line fixtures | |
| Controller (required) | PixlKontrol™ Driver/Controller | |
| Other Operating Modes | Standalone, Master/Slave, Auto, Sound Active | |
| Other Information | | |
| Yes. Is time travel possible? | | |
| Warranty | | |
| 2-year limited warranty, does not cover malfunction caused by damage to LEDs. | | |

Dimensional Drawings

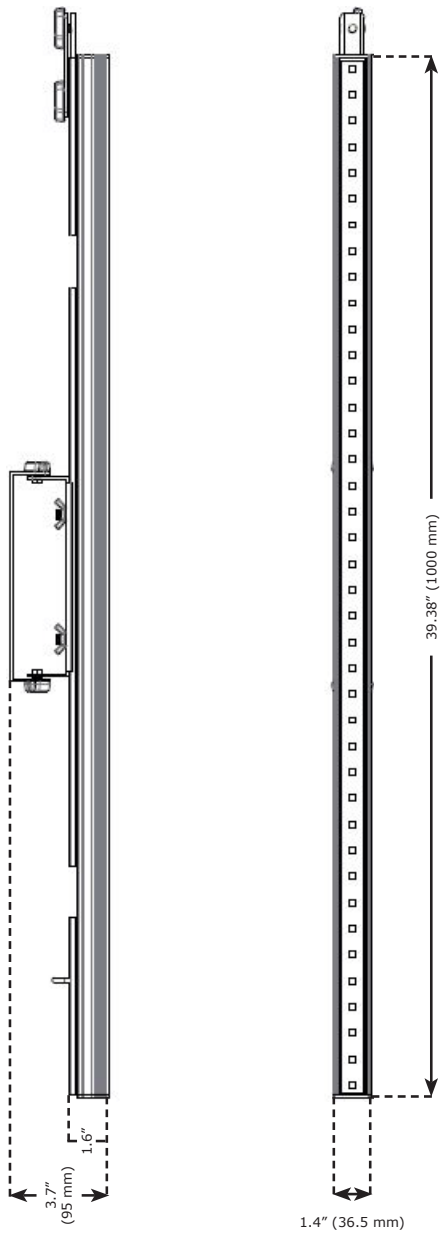

This page intentionally left blank.

This page intentionally left blank.



Enjoy your product!
Our sincerest thanks for your purchase!
--The team @ Blizzard Lighting