

**HILIGHT™ SERIES ENGINEERING INFORMATION**

The THL-811S is a 2-way professional loudspeaker in a skeletonised fixed installation format incorporating Turbosound's unique loading principles. The modular loudspeaker is designed to cover mid and high frequencies in the range from 180Hz to 20kHz in primary sound reinforcement systems.

The THL-811S is used in conjunction with bass enclosures from the Turbosound range, such as the THL-818 or THL-828, and the TSW-721 or TSW-124 subwoofer enclosures. System control is provided by the LMS-D6 or LMS-A6 loudspeaker management systems, which offer crossover and limiting functions.

The loudspeaker does not rely on an enclosure for its acoustic performance, therefore the cabinet has been eliminated in this design in order to provide a significant cost saving. The THL-811S is also smaller and lighter than a conventional loudspeaker cabinet, and because of this can easily be flown in tight corners where space is limited.

The components are positioned by means of lightweight brackets which also form part of the integral flying system.

The THL-811S incorporates a custom 10" mid-range driver loaded with a TurboMid™ device covering frequencies in the range 180Hz to 4kHz; and a custom 1" high frequency driver on a proprietary horn flare covering frequencies from 4kHz to 20kHz. A new HF driver loading technique unique to Turbosound dramatically reduces distortion at high frequencies, resulting in cleaner HF response and greater transient detail.

It features a tightly controlled dispersion pattern of 55° horizontal by 40° vertical. This permits the loudspeaker to be accurately focused into areas such as a nightclub dancefloor or a theatre auditorium without overspill into other areas.

**Recommended complementary products:**

**THL-818, THL-828 bass enclosures**

**TSW-721, TSW-124 subwoofer enclosures**

**LMS-D6, LMS-D4 loudspeaker management systems**

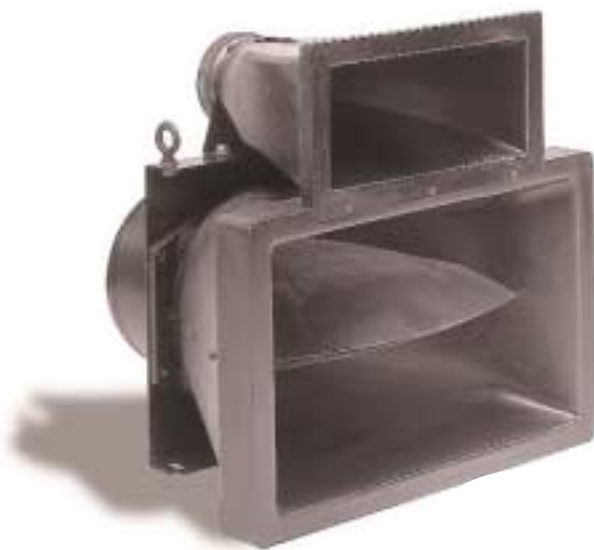
**FEATURES**

Dedicated fixed installation format

Reduced size/weight

Ultra-low distortion

Controlled dispersion

Integral rigging points

**APPLICATIONS**

Nightclub/discothque

Conference centres

Sports facilities

<b>DIMENSIONS (HxWxD)</b>	535mm x 535mm x 480mm (21" x 21" x 18.9")
<b>NET WEIGHT</b>	17 kg ( 37.4lbs)
<b>COMPONENTS</b>	1 x 10" (254mm) MF driver on a TurboMid™ device, 1 x 1" (25mm) HF driver on a custom waveguide
<b>FREQUENCY RESPONSE<sup>1</sup></b>	180Hz - 20kHz ±4dB
<b>NOMINAL DISPERSION</b>	55°H x 40°V @ -6dB points
<b>POWER HANDLING</b>	150 watts r.m.s., 300 watts program, 375 watts peak Recommended amplifier power: 300 watts @ 16 ohms
<b>SENSITIVITY</b>	105dB, 1 watt @ 1 metre (average)
<b>MAXIMUM SPL</b>	129dB continuous <sup>4</sup> , 135dB peak <sup>5</sup>
<b>CROSSOVER</b>	Internal passive crossover at 4kHz, third order high pass, Linkwitz-Riley
<b>IMPEDANCE</b>	16 ohms nominal
<b>CONSTRUCTION</b>	Dedicated skeleton installation format. Two M10 eyebolts included.
<b>SPARES AND ACCESSORIES</b>	LS-1015 10" (254mm) LF loudspeaker RC-1015 Recone kit for LS-1015 CD-165 1" (25mm) HF compression driver RD-165 Replacement diaphragm for CD-105 PX-811 Passive crossover

Notes

<sup>1</sup>Measured on axis

<sup>2</sup>Average over stated bandwidth

<sup>3</sup>Average over stated bandwidth

<sup>4</sup>Unweighted diode-clipped pink noise. Measured in a half space environment

<sup>5</sup>Verified by subjective listening tests of familiar program material, before the onset of perceived signal degradation

**FREQUENCY RESPONSE**

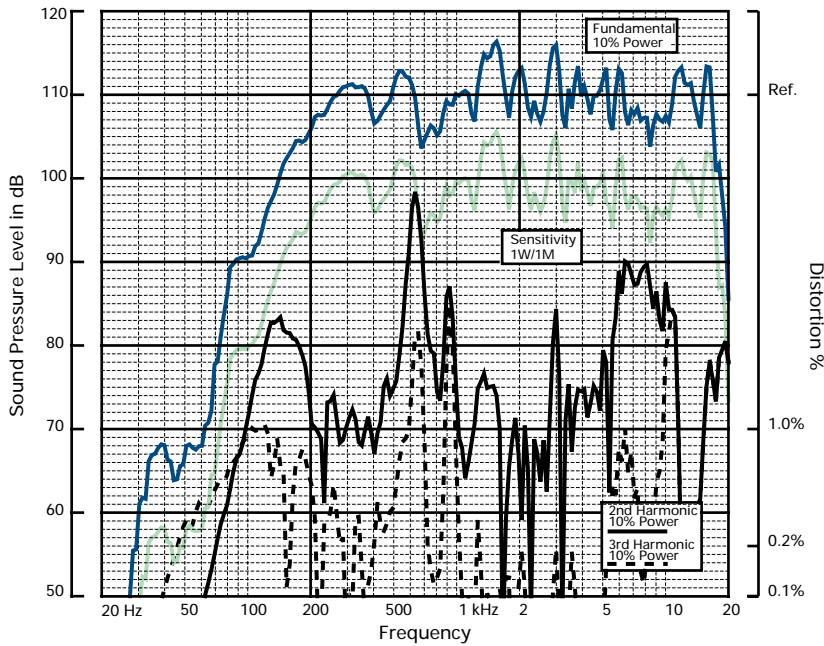

**IMPEDANCE**

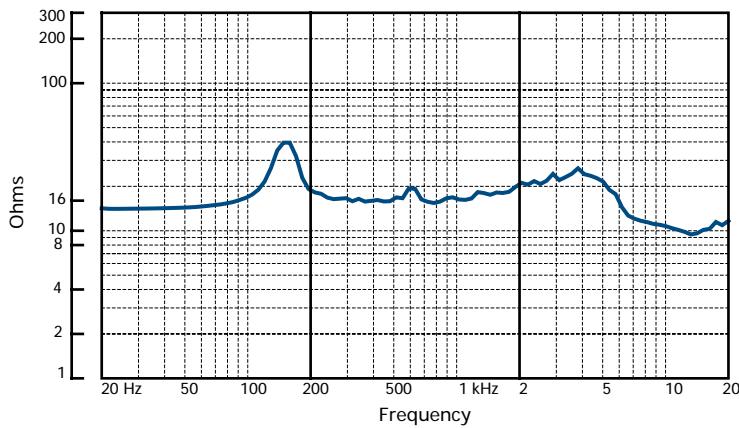

**Impedance** A constant current circuit was used to measure the impedance. **Frequency response** The frequency response shown was obtained by feeding a swept sine wave through the system in a half space environment. The position of the microphone was vertically on-axis at a distance of 2 metres, then scaled to represent 1 metre. **2nd & 3rd Harmonic Distortion** Distortion measurements were obtained using an Audio Precision harmonic distortion analysis system and comply with AES recommendations for enclosure measurement (AES paper ANSI S4-26-1984). **Data Conversion** All graphs were digitally generated using the APEX custom software system, designed to translate data derived from Audio Precision 'System One' test equipment into AutoCAD™. This program enables graphical information to be plotted to a high degree of accuracy.

**NOTES ON MEASUREMENT CONDITIONS**

**HORIZONTAL THIRD  
OCTAVE POLARS**

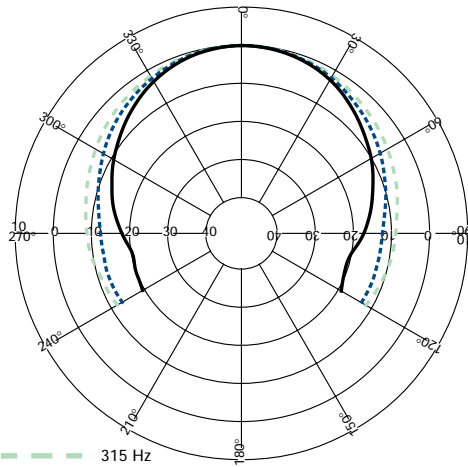

--- 315 Hz  
... 400 Hz  
— 500 Hz

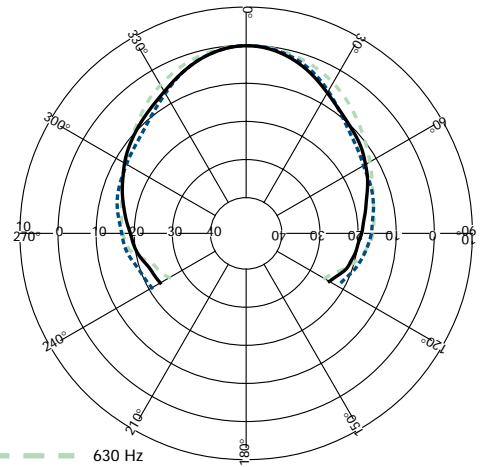

--- 630 Hz  
... 800 Hz  
— 1 kHz

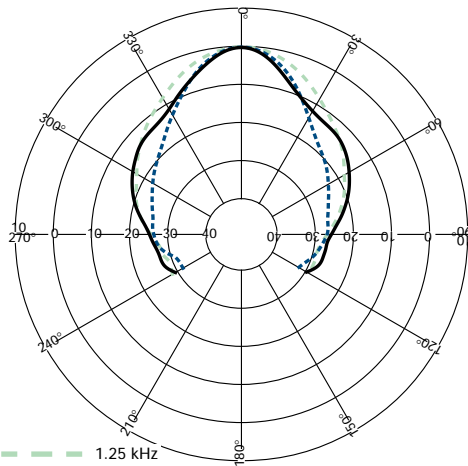

--- 1.25 kHz  
... 1.6 kHz  
— 2 kHz

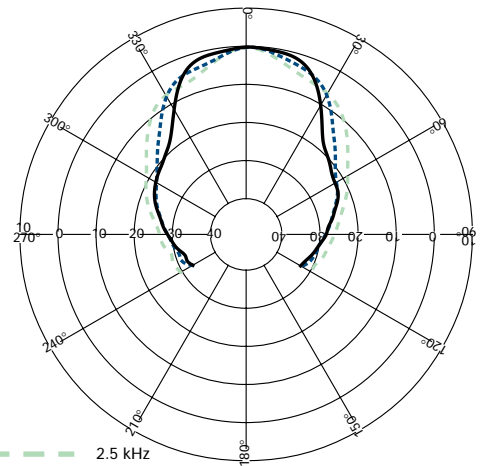

--- 2.5 kHz  
... 3.15 kHz  
— 4 kHz

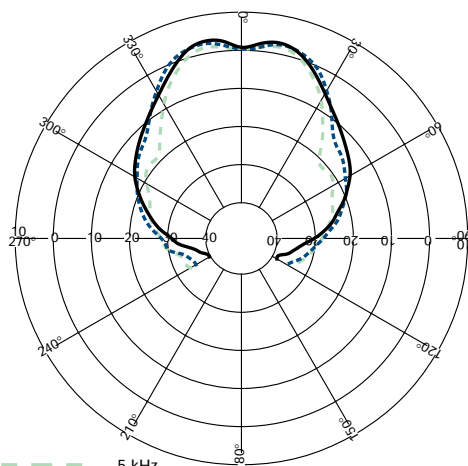

--- 5 kHz  
... 6.3 kHz  
— 8 kHz

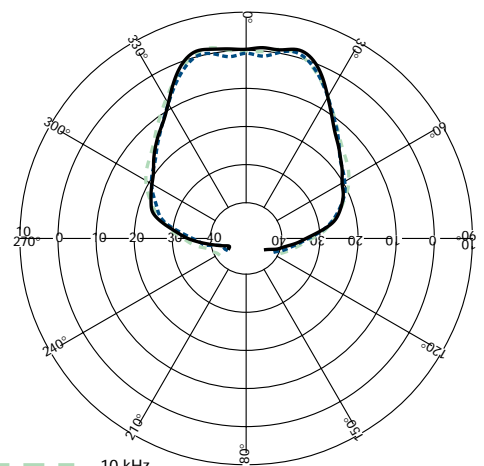

--- 10 kHz  
... 12.5 kHz  
— 16 kHz

VERTICAL THIRD  
OCTAVE POLARS

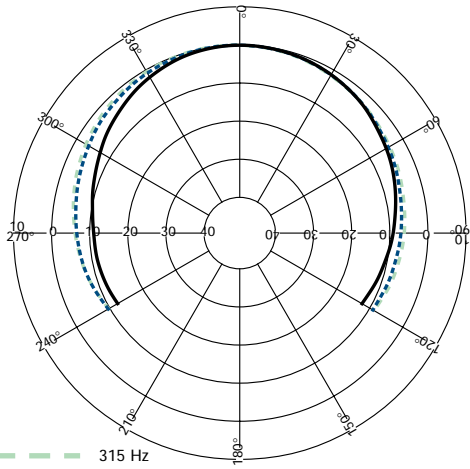

- 315 Hz
- ... 400 Hz
- 500 Hz

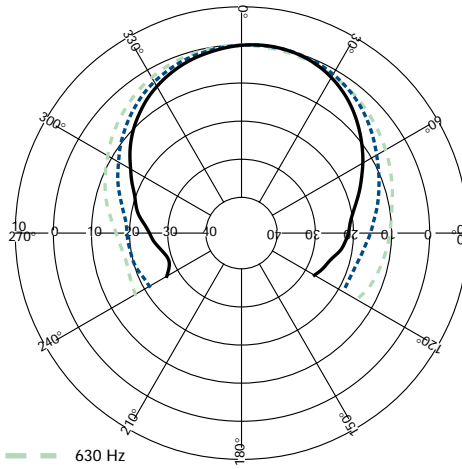

- 630 Hz
- ... 800 Hz
- 1 kHz

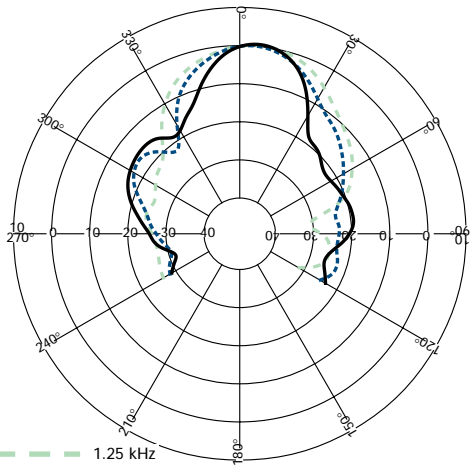

- 1.25 kHz
- ... 1.6 kHz
- 2 kHz

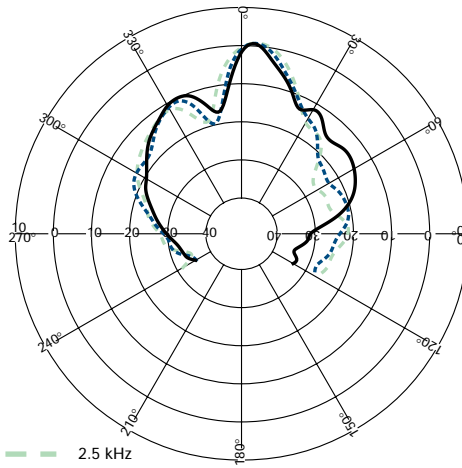

- 2.5 kHz
- ... 3.15 kHz
- 4 kHz

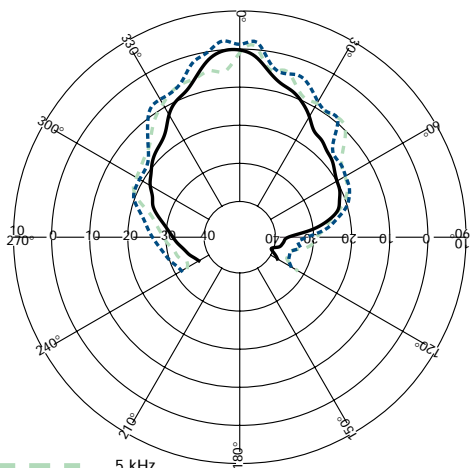

- 5 kHz
- ... 6.3 kHz
- 8 kHz

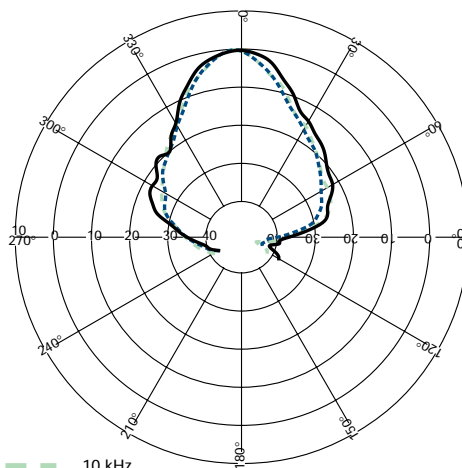

- 10 kHz
- ... 12.5 kHz
- 16 kHz

**BEAMWIDTH**

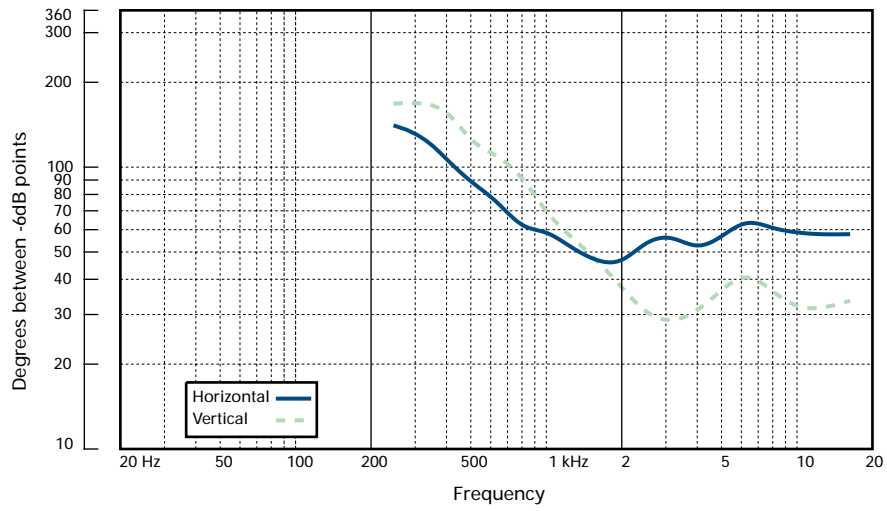

**DIRECTIVITY**

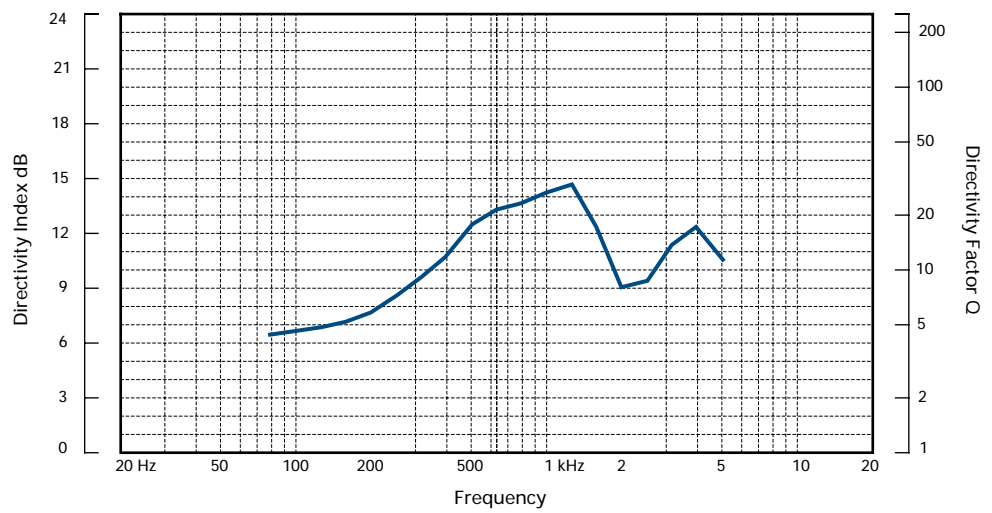

The THL-811S may be permanently installed using the eyebolts provided on the skeleton frame. Downward inclination is set by attaching to the holes provided at the bottom of the frame.

FLYING HARDWARE

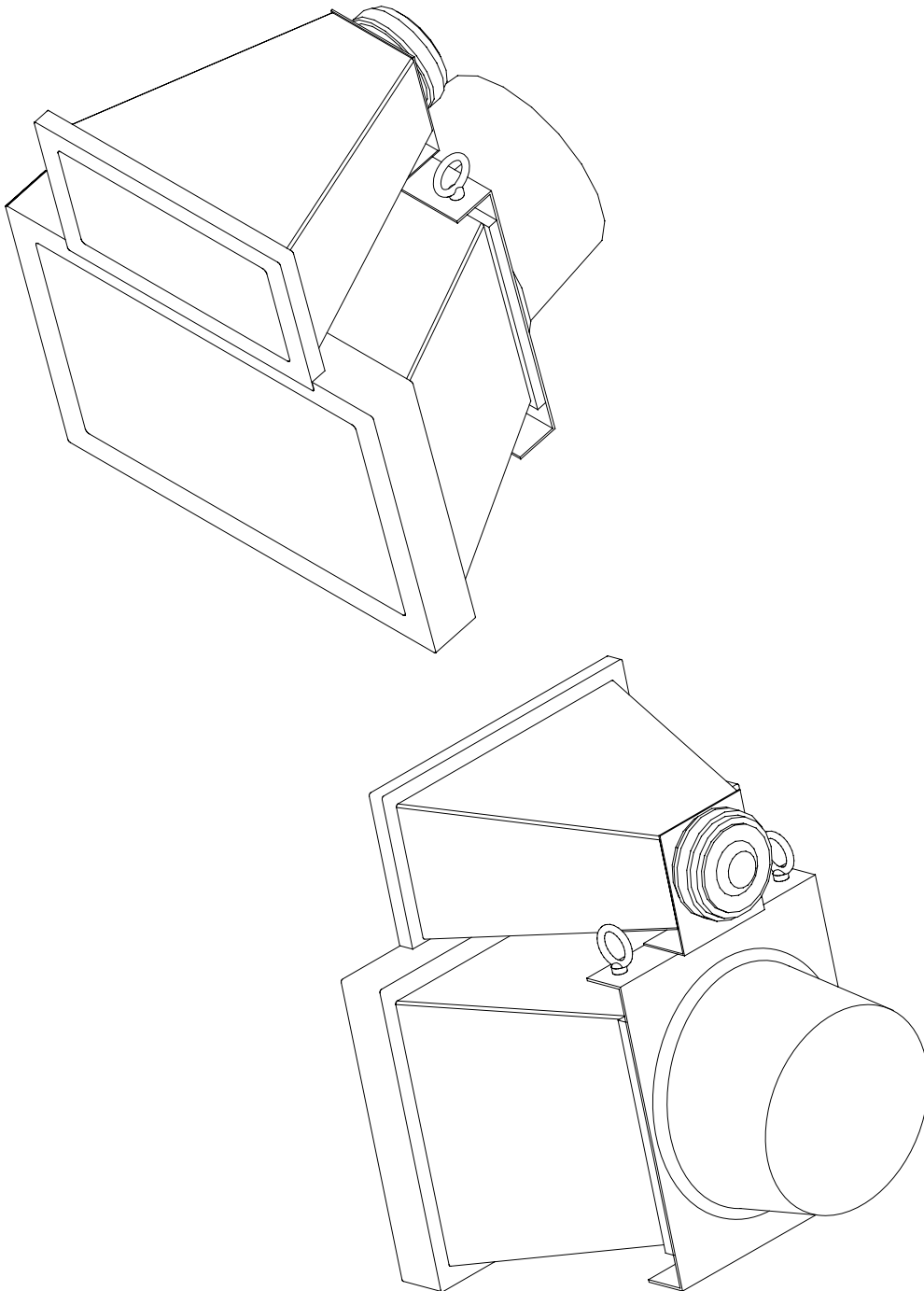

**ARCHITECTURAL  
& ENGINEER'S  
SPECIFICATIONS**

The loudspeaker shall be of the mono-amped, skeleton mid-high type, consisting of one 10" (254mm) mid frequency loudspeaker loaded with a TurboMid™ device and a 1" (25mm) high frequency compression driver. Performance specifications of a typical production unit shall be: Frequency response, measured with swept sine wave input, shall be flat within  $\pm 4\text{dB}$  from 180Hz to 20kHz. Nominal dispersion at  $-6\text{dB}$  points shall average  $55^\circ$  horizontal by  $40^\circ$  vertical. Nominal impedance shall be 16 ohms. Power handling shall be 150 watts r.m.s., 300 watts program, 375 watts peak. Sensitivity, measured with 1 watt input at 1 metre distance on axis, mean averaged over stated bandwidth, shall be 105dB. Maximum SPL (peak) measured with music program at stated amplifier power shall be 135dB. Dimensions: 535mmH x 535mmW x 480mmD (21" x 21" x 18.9"). Weight: 17 kg (37.4 lbs). The loudspeaker shall be the THL-811S. No other loudspeaker shall be acceptable unless submitted data from an independent test laboratory verify that the above combined performance/size specifications are equalled or exceeded. The facility to suspend the loudspeaker in fixed installations shall be provided.

**DIMENSIONS**

