

datavideo

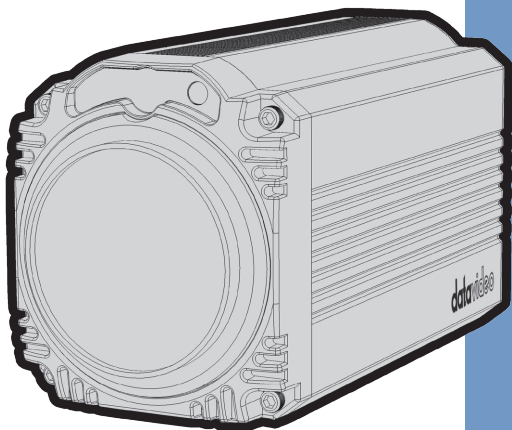

BLOCK CAMERA

BC-50

Instruction Manual

www.datavideo.com

Table of Contents

FCC COMPLIANCE STATEMENT	5
WARNINGS AND PRECAUTIONS	5
WARRANTY	6
STANDARD WARRANTY.....	6
THREE YEAR WARRANTY	7
DISPOSAL	8
1. INTRODUCTION	9
FEATURES.....	9
2. SYSTEM DIAGRAM	10
3. CONNECTIONS	10
FRONT VIEW	11
REAR PANEL	12
4. OSD MENU OPTIONS	15
5. EQUIPMENT SETUP AND INTERNET CONNECTION ...	24
5.1. OPERATING ENVIRONMENT	24
5.2. EQUIPMENT INSTALLATION	24
5.3. INTERNET CONNECTION	24
6. VISIT AND CONTROL THE BC-50 BY LAN	26

6.1. SETUP THE IP ADDRESS	26
6.2. CHANGE THE IP ADDRESS.....	27
6.3. VISIT/ACCESS THE BC-50	29
6.4 VLC STREAM MEDIA PLAYER MONITORING (FOR DECODING THE RTSP STREAMING).....	32
6.5. PARAMETER SETTING	35
<i>6.5.1 VLC User Interface Introduction.....</i>	35
6.6 HOMEPAGE CONTROL USER INTERFACE.....	36
<i>6.6.1 Language Selection</i>	36
<i>6.6.2 Live</i>	36
<i>6.6.3 Video.....</i>	40
<i>6.6.4 Image.....</i>	53
<i>6.6.5 Audio</i>	56
<i>6.6.6 System</i>	60
<i>6.6.7 Network.....</i>	62
<i>6.6.8 Information.....</i>	82
<i>6.6.9 Control Buttons on the Left Column of the Network Control Interface</i>	83
<i>6.6.10 Download the Network Upgrade Program</i>	86
6.7. HOW TO LIVE-STREAM BC-50'S VIDEO ON LIVE-STREAMING PLATFORM-TAKE FACEBOOK AS AN EXAMPLE	87
7. MAINTENANCE & WARNINGS	100
7.1. MAINTENANCE	100

8. FAILURES & TROUBLESHOOTING	102
9. DIMENSIONS	103
10. FREQUENTLY-ASKED QUESTIONS.....	104
11. SPECIFICATIONS	107
12. SERVICE AND SUPPORT	116

Disclaimer of Product & Services

The information offered in this instruction manual is intended as a guide only. At all times, Datavideo Technologies will try to give correct, complete and suitable information. However, Datavideo Technologies cannot exclude that some information in this manual, from time to time, may not be correct or may be incomplete. This manual may contain typing errors, omissions or incorrect information. Datavideo Technologies always recommend that you double check the information in this document for accuracy before making any purchase decision or using the product. Datavideo Technologies is not responsible for any omissions or errors, or for any subsequent loss or damage caused by using the information contained within this manual. Further advice on the content of this manual or on the product can be obtained by contacting your local Datavideo Office or dealer.

FCC Compliance Statement

This device complies with part 15 of the FCC rules. Operation is subject to the following two conditions:

- (1) This device may not cause harmful interference, and
- (2) This device must accept any interference received, including interference that may cause undesired operation.

Warnings and Precautions



1. Read all of these warnings and save them for later reference.
2. Follow all warnings and instructions marked on this unit.
3. Unplug this unit from the wall outlet before cleaning. Do not use liquid or aerosol cleaners. Use a damp cloth for cleaning.
4. Do not use this unit in or near water.
5. Do not place this unit on an unstable cart, stand, or table. The unit may fall, causing serious damage.
6. Slots and openings on the cabinet top, back, and bottom are provided for ventilation. To ensure safe and reliable operation of this unit, and to protect it from overheating, do not block or cover these openings. Do not place this unit on a bed, sofa, rug, or similar surface, as the ventilation openings on the bottom of the cabinet will be blocked. This unit should never be placed near or over a heat register or radiator. This unit should not be placed in a built-in installation unless proper ventilation is provided.
7. This product should only be operated from the type of power source indicated on the marking label of the AC adapter. If you are not sure of the type of power available, consult your Datavideo dealer or your local power company.
8. Do not allow anything to rest on the power cord. Do not locate this unit where the power cord will be walked on, rolled over, or otherwise stressed.
9. If an extension cord must be used with this unit, make sure that the total of the ampere ratings on the products plugged into the extension cord do not exceed the extension cord rating.
10. Make sure that the total amperes of all the units that are plugged into a single wall outlet do not exceed 15 amperes.
11. Never push objects of any kind into this unit through the cabinet ventilation slots, as they may touch dangerous voltage points or short out parts that could result in risk of fire or electric shock. Never spill liquid of any kind onto or into this unit.

12. Except as specifically explained elsewhere in this manual, do not attempt to service this product yourself. Opening or removing covers that are marked “Do Not Remove” may expose you to dangerous voltage points or other risks, and will void your warranty. Refer all service issues to qualified service personnel.
13. Unplug this product from the wall outlet and refer to qualified service personnel under the following conditions:
 - a. When the power cord is damaged or frayed;
 - b. When liquid has spilled into the unit;
 - c. When the product has been exposed to rain or water;
 - d. When the product does not operate normally under normal operating conditions. Adjust only those controls that are covered by the operating instructions in this manual; improper adjustment of other controls may result in damage to the unit and may often require extensive work by a qualified technician to restore the unit to normal operation;
 - e. When the product has been dropped or the cabinet has been damaged;
 - f. When the product exhibits a distinct change in performance, indicating a need for service.

Warranty

Standard Warranty

- Datavideo equipment is guaranteed against any manufacturing defects for one year from the date of purchase.
- The original purchase invoice or other documentary evidence should be supplied at the time of any request for repair under warranty.
- The product warranty period begins on the purchase date. If the purchase date is unknown, the product warranty period begins on the thirtieth day after shipment from a Datavideo office.
- All non-Datavideo manufactured products (product without Datavideo logo) have only one year warranty from the date of purchase.
- Damage caused by accident, misuse, unauthorized repairs, sand, grit or water is not covered under warranty.
- Viruses and malware infections on the computer systems are not covered under warranty.

- Any errors that are caused by unauthorized third-party software installations, which are not required by our computer systems, are not covered under warranty.
- All mail or transportation costs including insurance are at the expense of the owner.
- All other claims of any nature are not covered.
- All accessories including headphones, cables, batteries, metal parts, housing, cable reel and consumable parts are not covered under warranty.
- Warranty only valid in the country or region of purchase.
- Your statutory rights are not affected.

Three Year Warranty

- All Datavideo products purchased after July 1st, 2017 qualify for a free two years extension to the standard warranty, providing the product is registered with Datavideo **within 30** days of purchase.
- Certain parts with limited lifetime expectancy such as LCD panels, DVD drives, Hard Drive, Solid State Drive, SD Card, USB Thumb Drive, Lighting, Non-PCIe Card and third party provided PC components are covered for 1 year.
- The three-year warranty must be registered on Datavideo's official website or with your local Datavideo office or one of its authorized distributors within 30 days of purchase.



Disposal

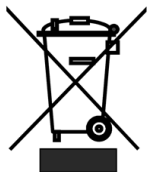

For EU Customers only - WEEE Marking

This symbol on the product or on its packaging indicates that this product must not be disposed of with your other household waste. Instead, it is your responsibility to dispose of your waste equipment by handing it over to a designated collection point for the recycling of waste electrical and electronic equipment. The separate collection and recycling of your waste equipment at the time of disposal will help to

conserve natural resources and ensure that it is recycled in a manner that protects human health and the environment. For more information about where you can drop off your waste equipment for recycling, please contact your local city office, your household waste disposal service or the shop where you purchased the product.



CE Marking is the symbol as shown on the left of this page. The letters "CE" are the abbreviation of French phrase "Conformité Européene" which literally means "European Conformity". The term initially used was "EC Mark" and it was officially replaced by "CE Marking" in the Directive 93/68/EEC in 1993. "CE Marking" is now used in all EU official documents.

1. Introduction

The BC-50 is a cost-effective Full HD block camera which equips high quality super telephoto lens with 20X optical zoom and 16X digital zoom. The BC-50 Block Camera is a small HD camera that can deliver compressed video signals such as H.264, H.265 and MJPEG. The BC-50 block camera is made with sturdy and durable metal case which is suitable for HD camera applications in different environments. Moreover, the BC-50 block camera supports 1/2.7 inch 2.07 million pixels high quality HD CMOS sensor which can achieve maximum 1920x1080 high quality image.

Features

- HD Resolution: 1/2.7" High Definition 2.07 M Pixels CMOS sensor
- 20x Optical Zoom & 16X Digital Zoom
- High definition formats supported:
 - HD: 1080p/60/50/30/25
 - 1080i/60/50
 - 720p/60/50
- 2D & 3D Digital Noise Reduction Function (DNR) to reduce the noise and enable clearer image under low light conditions.
- Video Output: 3G-SDI outputx1, Network outputx1
- Support for external 3.5mm wire connecting with TB-5 Tally Box
- Support for video format up to 1080P60
- Support for AAC Audio Encoding

2. System Diagram

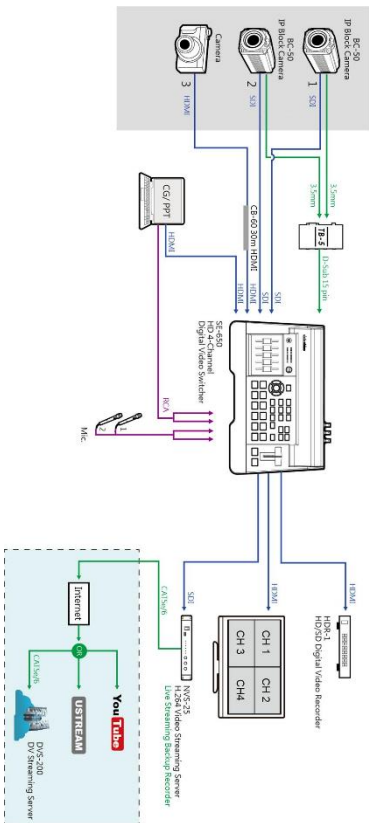

3. Connections





Front View



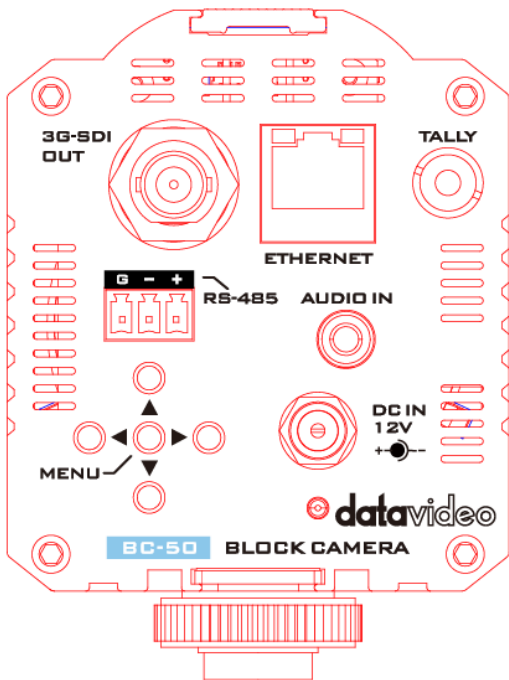

Tally Light	This tally LED is used to receive the tally signal by the 3.5mm wire from the tally box connected to the switcher. If the switcher transmits a PGM signal to the camera, the tally LED will light on in red. However, if the camera receives a PVW signal from the switcher, the tally LED will light on in green.
Lens	Camera lens for capturing images.

Rear Panel

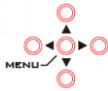

	3G-SDI Output	Video output(Type A) connected to SDI port of the monitor.
	RS-485 Control Port	Control port using the RS-485 control protocol. The max. distance is 1200m
	12V DC Power IN	DC in socket connects the supplied 12V PSU. The connection can be secured by screwing the outer fastening ring of the DC In plug to the socket.
	Power LED Indicator	The power LED keeps flashing when the camera is powered on.
	Tally Signal Port	This tally LED is used to receive the tally signal by the 3.5mm wire from the tally box connected to the switcher. If the switcher transmits a PGM signal to the camera, the tally LED will light on in red. However, if the camera receives a PVW signal from the switcher, the tally LED will light on in green.

<p>AUDIO IN</p> 	<p>Audio IN Port</p>	<p>Stereo, Line in level, this interface can be the audio output of the streaming. This audio input will not be embedded to the SDI output.</p>
 <p>ETHERNET</p>	<p>Ethernet Interface</p>	<p>This Ethernet interface is used for the internet connection for the BC-50 HD camera. Moreover, this interface also serves as the output interface through the Ethernet cable.</p>
	<p>In OSD Mode: MENU/Up /Down/Left /Right Keys</p> <p>In Normal BC-50 Output Screen without MENU OSD: Up=Zoom In Down=Zoom Out</p> <p>If the BC-50 is set at Manual Focus in advance. Left=Far Right=Near</p>	<p>This menu key set includes MENU/Up/Down/Left/Right keys. The MENU key is also the confirming key in menu selection. The Up key represents the Zoom-in function and the Down key represents the Zoom-Out function when the camera is in normal operation. If the BC-50 is set at manual Focus in advance and the BC-50 is in normal operation, the Left key represents Near and the right key represents Far.</p>

4. OSD Menu Options

On-Screen Menu allows the user to change various camera settings such as shooting conditions and the system setup. Press **MENU** button on the **rear panel of the BC-50** to enter the on-screen menu as shown below. The BC-50 HD camera provides five keys on the rear panel including MENU, Up, Down, Left side and Right side for users to control the camera. Please see following tables for MENU options of each category.

MENU

1. Exposure
2. Color
3. Image
4. Focus
5. Noise Reduction
6. Setting
7. Information
8. Restore Default
9. Exit

Main Options	Exposure	Color	Image	Focus	Noise Reduction
Sub-Options	1.Mode	1.WB Mode	1.Luminance	1.D-Zoom Limit	1.2D NR
	2.ExpCompMod	2.AWB Sens	2.Contrast	2.AF Sensitivity	2.3D NR
	3. ExpComp	3.RG Tuning	3.Sharpness	3.Auto Focus	3.Return
	4. GainLimit	4.BG Tuning	4.Flip-H	4.Return	
	5. Backlight	5.Saturation	5.Flip-V		
	6. DRC Strength	6.Hue	6.Gamma		
	7. Anti Flicker	7.Return	7.Style		
	8. Return		8.Return		

Main Options	Setting	Information	Restore Default	Exit
Sub-Options	1.Language	1.Version	1.Yes	
	2.Protocol	2.Model	2.No	
	3.VISCA Address	3.Date	3.Return	
	4.Baudrate	4.AF Version		
	5.Video Format	5.IP		
	6.Lens	6.Gateway		
	7.Return	7.Netmask		
		8.Return		

1 st Layer Main Options	2 nd Layer Sub-Options	3 rd Layer Parameter
1.Exposure	1.Mode	Auto
		Bright
		Iris Priority
		Shutter Priority
		Manual
		WDR
	2.ExpCompMod	On
		Off
	3.ExpComp	-7
		-6
		-5
		-4
		-3
		-2
		-1
		0
		1
		2
		3
		4
		5
		6
	4.Gain Limit	7
		0
		1
		2
		3
		4
5		
6		
7		
8		
9		
10		
11		
12		
13		

			14
			15
		5.Backlight	On
			Off
		6.DRC Strength	0
			1
			2
			3
			4
			5
			6
			7
		7.Anti Flicker	8
			50Hz
60Hz			
8.Return	Off		
2. Color	1.WB Mode	Auto	
		3000K/Indoor	
		4000K	
		5000K/Outdoor	
		6500K-1	
		6500K-2	
		6500K-3	
		One Push	
	Manual		
	2.AWB Sens	Low	
		Middle	
		High	
	3.RG Tuning	-10~10	
	4.BG Tuning	-10~10	
5.Saturation	60%		
	70%		
	80%		
	90%		
	100%		
	180%		
	110%		
	120%		
130%			

		140%
		150%
		160%
		170%
		180%
		190%
		200%
	6.Hue	0
		1
		2
		3
		4
		5
		6
		7
		8
		9
		10
		11
		12
13		
14		
	7.Return	
3.Image	1.Luminance	0
		1
		2
		3
		4
		5
		6
		7
		8
		9
		10
		11
		12
		13
	14	
2.Contrast	0	
	1	
	2	
	3	

				4	
				5	
				6	
				7	
				8	
				9	
				10	
				11	
				12	
				13	
				14	
			3.Sharpness		0
					1
					2
	3				
	4				
	5				
	6				
	7				
	8				
	9				
	10				
	11				
	12				
	13				
	14				
4.Flip-H		On			
		Off			
5.Flip-V		On			
		Off			
6.Gamma		default			
		0.45			
		0.5			
		0.56			
		0.63			
7.Style		Norm			
		Clarity(LED)			
		5S			
		Soft			

		Bright					
		Clarity					
	8.Return						
4.Focus	1.D-Zoom Limit	X1					
		X2					
		X4					
		X8					
		X16					
	2.AF Sensitivity	Low					
		Middle					
		High					
	3.Auto Focus	On					
		Off					
4.Return							
5.Noise Reduction	1. 2D NR	1					
		2					
		3					
		4					
		5					
		Close					
		Auto					
	2. 3D NR	1					
		2					
		3					
		4					
		5					
		6					
		7					
		8					
		Close					
	3.Return						
	6. Setting	1.Language	English				
			Traditional Chinese				
Simplified Chinese							
2.Protocol		VISCA					
		PELCO-P					
		PELCO-D					
3.Address		VIS	1	P-P Addr ess	0~31	P-D Add ress	0~ 254
		CA	2				
			3				

		Add ress	4				
			5				
			6				
			7				
	4.Baud Rate	38400					
		19200					
		9600(default)					
		4800					
		2400					
	5.Video Format	1080P25					
		1080P30					
		1080P50					
		1080P60					
		1080I60					
		1080I50					
		720P50					
		720P60					
	6.Lens	Type2					
	7.Return						
7.Information	1.Version						
	2.Model						
	3.Date						
	4.AF Version						
	5.IP						
	6.Gateway						
	7.Netmask						
	8.Return						
8.Restore Default	1.Yes						
	2.No						
	3.Return						
9.Return							

5. Equipment Setup and Internet Connection

5.1. Operating Environment

Operating System	Windows2000/2003/XP/Vista/7/8
Network Protocol	TCP/IP
Client PC	P4/128MRAM/40GHD/ support scaled graphics card, support DirectX8.0 or more advanced version.

5.2. Equipment Installation

Please follow following steps for installing the BC-50 Full HD block camera.

(1) Connect BC-50 directly to your internet or to your PC through Ethernet cable.

(2) Connect the BC-50 camera with the DC 12V power cable. After the DC 12V power is connected, the power LED below the DC 12V power connector will flash.

5.3. Internet Connection

When the power is connected, the orange light of the Ethernet port will light on. After the Ethernet cable is connected, the green light will flash and then the physical connection of the BC-50 is completed.

Please refer to following figures for connecting the BC-50 and the computer or notebook PC.

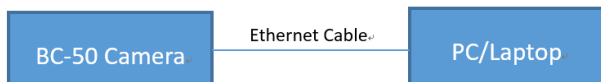

Figure1. Internet connection between the BC-50 and PC through Ethernet cable

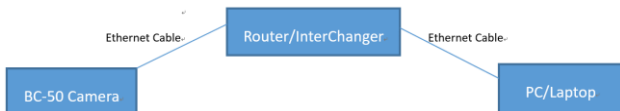

Figure2. Internet connection between the BC-50 and PC through router/interchanger

6. Visit and Control the BC-50 by LAN

6.1. Setup the IP Address

The default IP address of the BC-50 Full HD block camera is “**192.168.100.99**”. For users who do not know the BC-50 IP address, please follow following steps for finding the BC-50 default IP address.

Finding IP address by OSD: Connect the BC-50 Full HD block camera to a monitor or TV. After that, please press the **MENU** key on the rear panel of the camera.

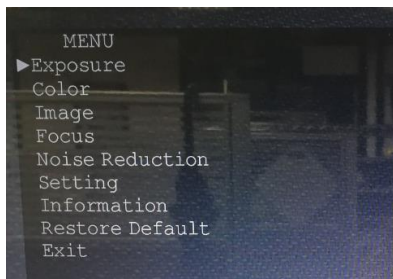

After entering into the main menu, please select the **Information**, and then the camera IP of the BC-50 will be shown on the screen.

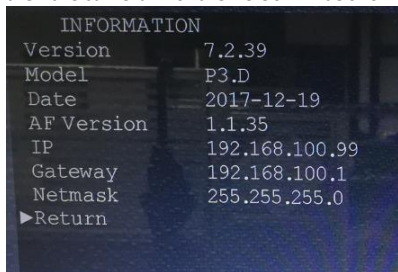

6.2. Change the IP Address

For users who want to change the IP address of the BC-50 Full HD block camera, there are two methods that are shown as following.

Method 1:

1. Please connect the fixed network cable to the WAN port of a router.
2. Connect the BC-50 Full HD block camera to the router with an Ethernet cable.
3. Please connect your PC/notebook PC to the router with an Ethernet cable.
4. After that, open your browser (**It is recommended to use Microsoft IE browser to achieve best performance**), input the default IP address “**192.168.100.99**”, and a window will pop-up and ask you to input the user name and password. The default user name & password is “**admin**”.



5. And then you can see the web control page of the BC-50 Full HD block camera.

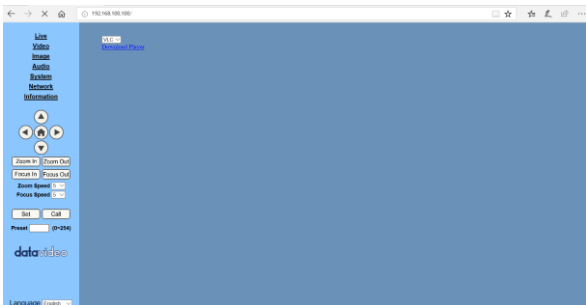

6. Click the “Network” on the left column and then you can see the network setting page.

7. After that, input new IP address in the blank of the IP address item as shown as following.

8. Click “Apply”

9. After that, please go to System>Reboot to reboot the BC-50. And then, please click the Apply button for rebooting it.



Method 2.

Please open the software “upgrade_En.exe”, input the new IP and then click “Set” as shown in the following. (Note: The latest version of the Upgrade software can be downloaded from Datavideo official website <https://www.datavideo.com/product/BC-50>)

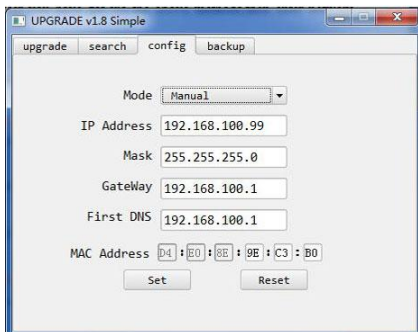

Note: The default IP address of the BC-50 Full HD block camera is “192.168.100.99”, and the default user/password is “admin”. After the IP address is modified, the BC-50 Full HD block camera will be restarted.

6.3. Visit/Access the BC-50

For users who want to visit/access the BC-50 Full HD block camera through the web interface, please refer to following steps.

1. Input the default IP address of the BC-50, “192.168.100.99” to the internet browser (it’s recommended to use IE web browser)
2. After that, a login window will pop-up and then input the default user name/password “admin”.



3. After entering into the web control page, the screen will be shown as following.

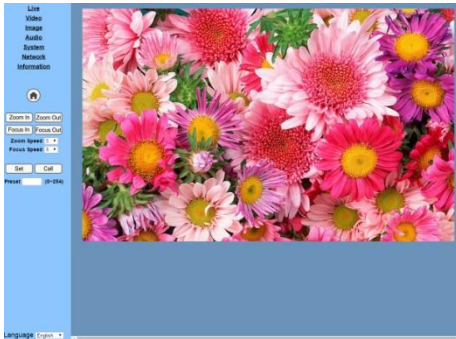

Note: For users who want to use the BC-50 Full HD block camera through the Internet for the first time (**for new user Only**), the VLC player software must be installed. For downloading VLC player, please go to VLC website: <http://www.videolan.org/vlc>. After installation, please login again, and the screen will show as above mentioned. The recommended browser for the Web UI is the Internet Explorer or the Firefox browser which the version is prior to 51.0.1. It's not recommended to use the Google Chrome.

6.4 VLC Stream Media Player Monitoring (For decoding the RTSP Streaming)

For setting the VLC Stream Media Player. Please refer to following steps. For the setting of the first stream video parameters, please go to the BC-50 web UI control interface and click Video ->First Stream for setting related parameters. For the setting of the second stream video parameters, please go to the BC-50 web UI control interface and click Video->Second Stream for setting related parameters.

1. Open the VLC media player,
2. Click "**Media**"->"**Open Network Stream** ", or click "**Ctrl+N**"

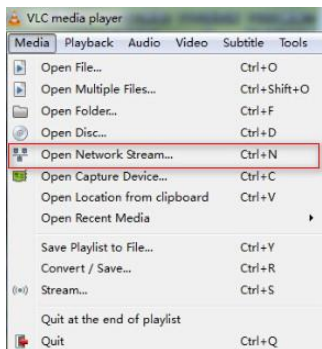

3. After that, please input URL addresses as following.

- `rtsp://ip: port number/1` (First stream);

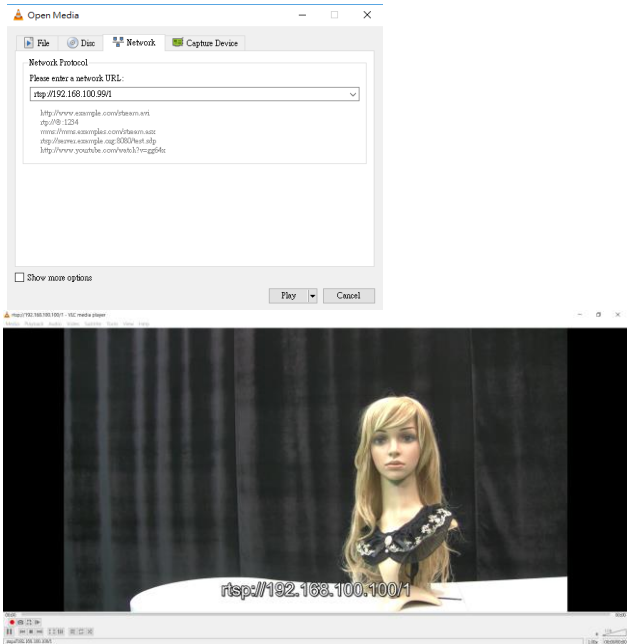

- `rtsp://ip: port number/2` (Second stream).

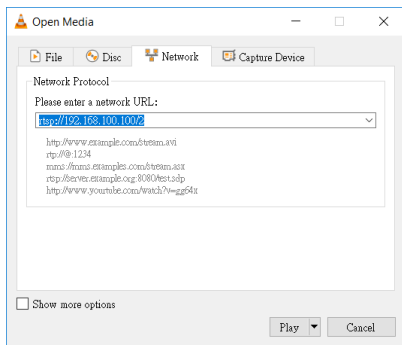

Please pay attention that the First stream encoding and Second stream encoding related parameters of the RTSP streaming must be set in Video → First stream/Second Stream in the Web UI.
Note: The default RTSP port number is 554.

6.5. Parameter Setting

6.5.1 VLC User Interface Introduction

Two main elements of the VLC user interface are shown as following.

Menu Bar	Function
Real Time Monitoring	Display video image
Parameter Setup	Include function buttons



Video Viewing Window

By clicking the “Live” option on the left column of the homepage control interface, users can see a VLC video viewing window. This VLC video viewing window is used for real-time monitoring of the RTSP streaming of the BC-50.

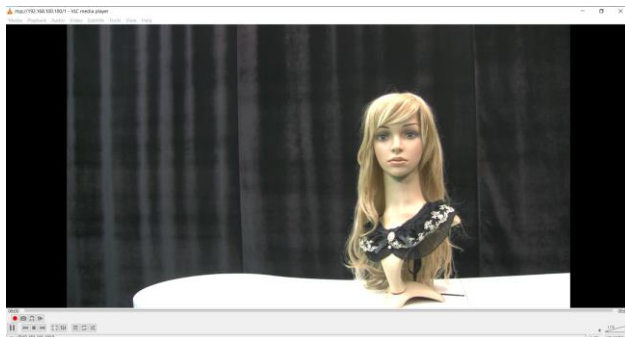
The resolution of the video viewing window must be the same as the video resolution. Higher resolution achieves larger playing area. If you want to enlarge the video viewing window to full-screen size, please double-click the viewing window. If you want to shrink the viewing window to its initial size, what you have to do is to double-click the full-screen window again. The status bar of the viewing window is shown as below.



The main control buttons of the status bar are described as following.

- Video playback pause button : Users can use this button to control real-time video pause/stop. When the real-time video playing is paused or stopped, click this button again can resume the video playing.
- Audio control button : This button can set the video playing in silent mode.
- Full screen switch button : Users can use this button to switch between full-screen and normal size screen.

6.6 Homepage Control User Interface

The BC-50 provides homepage control user interface for users. There are several main options in the homepage control user interface including Live, Video, Image, Audio, System, Network and Information.

6.6.1 Language Selection

The homepage control interface of the BC-50 Full HD block camera provides four language options for users including English, simplified Chinese, traditional Chinese and Russian.



6.6.2 Live

The “Live” option is the first option on the left column of the BC-50 network control interface which is shown as follows. In this “Live” option, if the VLC player is installed, user can see that there is an embedded real-time monitoring video that is decoded by the VLC player. If the IE option is selected, a plug-in must be downloaded by users for video decoding (Not available yet).

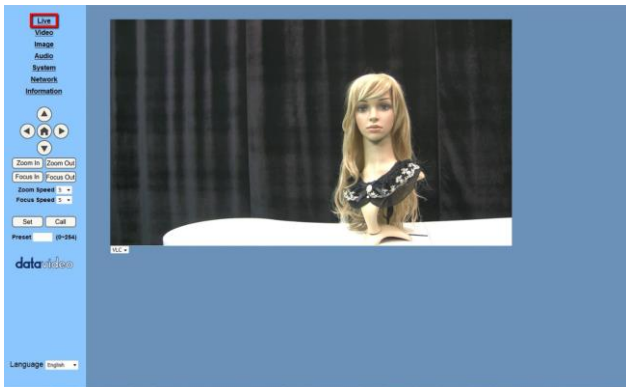

The “Live” option is used for live-monitoring the video of the BC-50. After the “Live” interface is shown, users can click the drop-down menu on the right side. After that, users can see two items including VLC and IE. The VLC option in the “Live” menu allows for embedded VLC decoding. If the IE is not available, for example, Chrome is the only web browser for users. In this situation, users can not see the decoded video due to that the VLC plug-in is not supported by the Chrome web browser. So, users must install the VLC media player in their system for decoding the RTSP streaming.

- VLC: Please following followings steps to know how to apply VLC player for live-monitoring.

Step 1. Before you start to use the VLC player for live-monitoring, please make sure that the latest version of the VLC player is installed in your PC. If you don’t have VLC player in your computer, please click the link [Download Player](#) which is shown below the drop-down menu to download the latest VLC player.

Step 2. After the VLC player is installed, please open the VLC player.

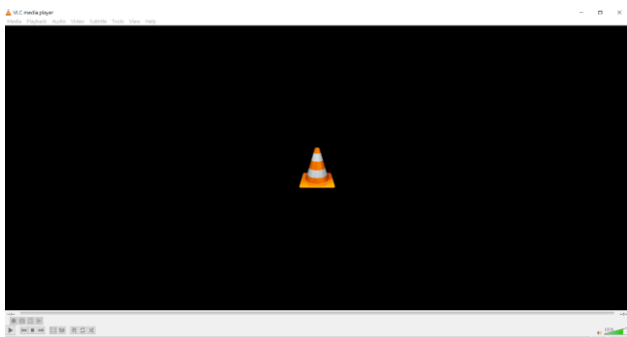

Step 3. Please click the “Open Network Stream” from the “Media” drop-down menu.

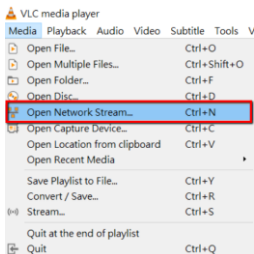

Step 4. Please enter the real-monitoring streaming URL into the blank of the “Open Media” window. The default format of the link is `rtsp://ip address: port No/1`. In this example, the default IP address of the BC-50 block camera is **192.168.100.99**. The default port No. of the rtsp protocol is **554**. So, please enter the URL

“rtsp://192.168.100.99:554/1” which is shown as following diagram and then please press the “Play” button.

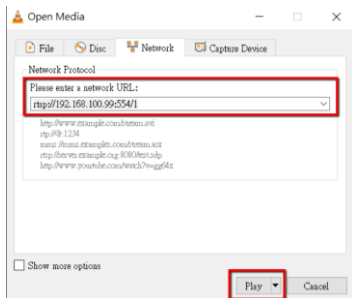

Step 5. After the play button is pressed, users can see the live-monitoring screen through the VLC player which is shown as following.

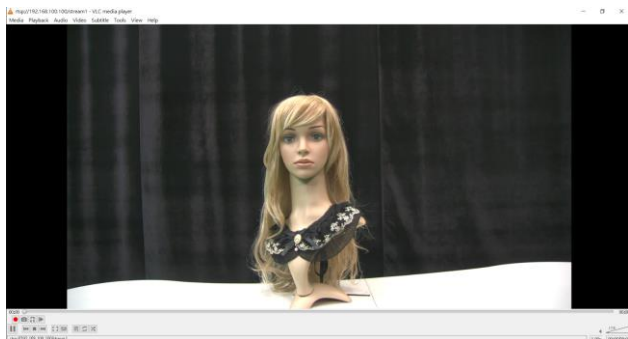

- IE: If this IE live-monitoring option is selected, users must download the VLC plug-in for real-monitoring (Not available yet).

6.6.3 Video

The “Video” option is the second option on the left column of the BC-50 network control interface which is shown as follows.

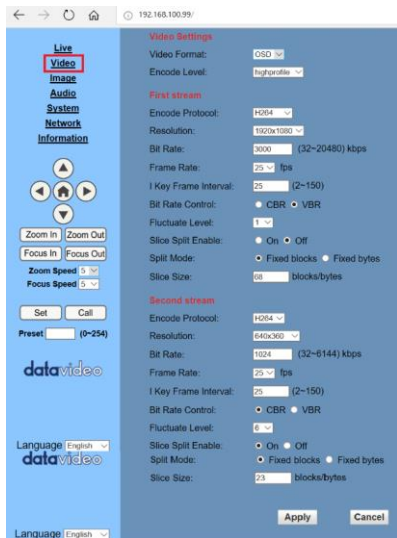

Please see following paragraphs for details of each item in the Video option.

- Video Format: The Video Format option supports for three formats including 50Hz, 60Hz and OSD (The OSD frequencies are set by the OSD options). Please follow following steps for setting the video format.

Step 1. Please click the Video Format option to show the drop-down menu which is shown as follows.

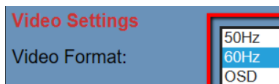

Step 2. Users can see that there are three video format options including 50Hz, 60Hz and OSD.

Step 3. Please choose your desired video format and then press the Apply button on the bottom of the interface and then the video format of the BC-50 is set successfully. The 50Hz/60/Hz/OSD means that users can set the BC-50 video format to be 50Hz,60Hz or the same as the OSD frequency as your monitor.

- Encode Level: The Encode Level option provides three encoding level including baseline, mainprofile and high profile for users to set the video quality of the BC-50 which is compressed in H.264 video format. For the H.265 and MJPEG, the available Encode level will be fixed at mainprofile only. The main profile is used in aspect such as the standard definition TV. The baseline profile is used in aspect such as the live-streaming through handset. The high profile is used in aspect such as HDTV broadcasting service and Blu-ray Disk.

Please follow following steps for setting the Encode Level.



Step 1. Please click the Encode Level option to show the drop-down menu which is shown as follows.



Step 2. Users can see that there are four encode level options including baseline, mainprofile and highprofile.

- For H.264: The available encode level options are baseline, mainprofile and highprofile.
- For H.265 and MJPEG, The available encode level option is fixed at mainprofile only.

Step 3. Please choose your desired H.264 encode level and then press the Apply button  on the bottom of the interface and then the encode level of the BC-50 video is set successfully.

Step 4. Please go back to the “**system**” menu  and then click the “**Reboot**” button . Finally, please click the “**Apply**” button  again and the new setting will be effective.

*Please pay attention that the “Encode Level” option must be used depending on the selection of the Encode protocol option.

- Encode Protocol: This option provides three encoding protocols including H.265, H.264 and MJPEG for users to choose their preferred encoding protocol for the BC-50 video encoding.

Please follow following steps for setting the Encode Protocol.

Step 1. Please click the Encode Protocol option to show the drop-down menu which is shown as follows

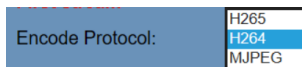

Step 2. Users can see there are three encode protocol options including H.265, H.264 and MJPEG.

Step 3. Please choose your desired Encode Protocol and then press the Apply button on the bottom of the interface and then the encode protocol of the BC-50 video is set successfully.

Step 4. Please go back to the “**system**” menu and then click the “**Reboot**” button . Finally, please click the “**Apply**” button again and the new setting will be effective.

*Please pay attention that if the Encode Protocol is set at MJPEG, some items including Encode Level, I Key Frame Interval, Fluctuate Level, Bit Rate Control, Slice Split Enable, Split Mode and Slice Size will become unmodifiable for users.

- Resolution: The Resolution option provides users several BC-50 video resolutions to choose which are shown as following

First stream flow:

- 1920 x 1080
- 1280 x 720
- 1024 x 576
- 960 x 540

- 640 x 480
- 640 x 360

Second stream flow:

- 1280x720
- 1024x576
- 720x480
- 720x408
- 640x360
- 480x270
- 320x240
- 320x180

Note: Higher resolution achieves clearer image. However, it occupies more network bandwidth.

Please follow following steps for setting the Resolution.

Step 1. Please click the Resolution option to show the drop-down menu which is shown as follows.

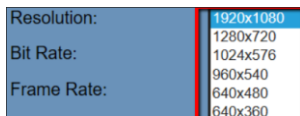

Step 2. Users can see there are several resolutions depending on the selected video format.

Step 3. Please choose your desired resolution and then press the Apply button on the bottom of the interface and then the resolution of the BC-50 video is set successfully.

Step 4. Please go back to the “**system**” menu **System** and then click the “**Reboot**” button **Reboot**. Finally, please click the “**Apply**” button **Apply** again and the new setting will be effective.

- Bit Rate: Users can set the bit rate of the BC-50 video by this option which is shown as follows.

Bit Rate: (32~20480) kbps

Generally speaking, higher bit rate achieves clearer image. However, it depends on network bandwidth situation. If the network bandwidth is insufficient and the allocated bit flow value is too high, it is hard for the video signal flow to transmit normally. Finally, it will cause worse video quality.

Please follow following steps for setting your desired bit rate for the BC-50 video.

Step 1. Please enter your desired bit rate manually in the blank of the bit rate option which is shown as below diagram. The entered bit rate range can be 32~20480kbps.

Bit Rate: (32~20480) kbps

Step 2. After the desired bit rate is entered, please press the Apply button **Apply** on the bottom of the interface and then the bit rate of the BC-50 video is set successfully.

Step 3. Please go back to the “**system**” menu **System** and then click the “**Reboot**” button **Reboot**. Finally, please click the “**Apply**” button **Apply** again and the new setting will be effective.

- **Frame Rate:** Frame rate is the frequency (rate) at which consecutive images called frames appear on a display. Users can determine the frame rate by adjusting this option. Higher frame rate achieves smoother image quality. However, users will feel more screen beating if the frame rate is too low.

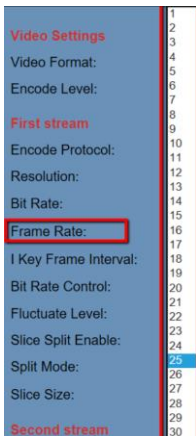

Please follow following steps for setting your desired Frame Rate for the BC-50 video.

Step 1. Please click the Frame Rate option to show the drop-down menu which is shown as follows.



Step 2. Users can see that there are several frame rates from 1 to 30 in the drop-down menu.

Step 3. Please select your desired frame rate from the drop-down menu and then press the Apply button  on the bottom of the interface and then the frame rate of the BC-50 video is set successfully.

Step 4. Please go back to the “system” menu  and then click the “Reboot” button . Finally, please click the “Apply” button  again and the new setting will be effective.



- I Key Frame Interval: This function can set interval from 2 to 150. If the I Key Frame interval value is higher, it needs more time for a picture to be resumed to a complete picture once the mosaics are existed in the pictures. However, the lower I Key Frame interval value reduces the time needed for a picture to be resumed to a complete picture once the mosaics are existed in the pictures. Moreover, it occupies more bandwidth once the I Key Frame interval value is lower.

Please follow following steps for setting your I Key Frame interval for the BC-50 video.

Step 1. Please enter your desired I Key Frame Interval manually in the blank of the I Key Frame Interval option which is shown as below diagram. The entered I Key Frame Interval range can be 2~150

I Key Frame Interval: (2~150)

Step 2. After the desired I Key Frame Interval is entered, please press the Apply button  on the bottom of the interface and then the I Key Frame Interval of the BC-50 video is set successfully.

Step 3. Please go back to the “system” menu  and then click the “Reboot” button . Finally, please click the “Apply” button  again and the new setting will be effective.

- Bit Rate Control: This option is used for users to choose the bit rate control method including CBR and VBR. There are two ways for bit rate control including constant bit rate and variable bit rate.
 - Constant bit rate: Video coder will do the coding according to preset speed.
 - Variable bit rate: Video coder will adjust the coding speed based on the preset value to gain best image quality.

Please follow following steps for setting the Bit Rate Control for the BC-50 video.

Step 1. Please select your desired bit rate control method from the Bit Rate Control option which is shown as follows.



Step 2. After the desired bit rate control method is selected, please press the Apply button  on the bottom of the interface and then the bit rate control method of the BC-50 video is set successfully.

Step 3. Please go back to the “**system**” menu **System** and then click the “**Reboot**” button **Reboot**. Finally, please click the “**Apply**” button **Apply** again and the new setting will be effective.

- **Fluctuate Level:** This option is used for users to choose the fluctuate level of the BC-50 video to restrain the fluctuation magnitude of the variable rate. Users can select grade 1 to 6 to set this level. The setting of the Fluctuate Level only affects VBR, the lower value causes lower fluctuation.

Please follow following steps for setting the Fluctuate Level for the BC-50 video.

Step 1. Please click the Fluctuate Level option to show the drop-down menu which is shown as follows.

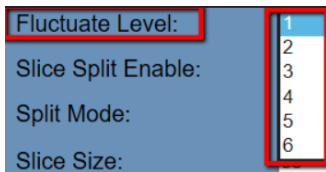

Step 2. Users can see there are six fluctuate levels from 1 to 6 in the drop-down menu.

Step 3. Please select your desired fluctuate level from the drop-down menu and then press the Apply button **Apply** on the bottom of the interface and then the fluctuate level of the BC-50 video is set successfully.

Step 4. Please go back to the “**system**” menu **System** and then click the “**Reboot**” button **Reboot**. Finally, please click the “**Apply**” button **Apply** again and the new setting will be effective.

- **Slice Split Enable: This function is advanced function and the default value for this function is OFF.** This option is used for users to turn on/turn off the slice split function. Please turn on this option only when the slice split function is a must for the video decoder. This option helps users to reduce a little network latency. However, it is not recommended to turn on this option in normal situation. Please see following steps for setting the Slice Split Enable function.

Step 1. Please click the On/Off option of the Slice Split Enable.

Slice Split Enable: On Off

Step 2. After the On or Off is selected, please press the Apply button **Apply** on the bottom of the interface and then the On/Off of the Slice Split function of the BC-50 video is set successfully.



Step 3. Please go back to the “**system**” menu **System** and then click the “**Reboot**” button **Reboot**. Finally, please click the “**Apply**” button **Apply** again and the new setting will be effective.

- **Split Mode:** This option allows users to choose two split modes including Fixed Blocks and Fixed Bytes. Those two split modes bring users similar outcomes. So, it depends on users for choosing the split mode. Please follow following steps for setting the split mode for the BC-50 video.

Step 1. Please select your desired split mode by clicking the circle next to the option.



Step 2. After the desired split mode is selected, please press the Apply button  on the bottom of the interface and then the split mode of the BC-50 video is set successfully.

Step 3. Please go back to the “**system**” menu  and then click the “**Reboot**” button . Finally, please click the “**Apply**” button  again and the new setting will be effective.

- Slice Size: This option is used for users to enter the desired slice size. If the entered value is higher than its limit, a dialog box will be shown to remind users. Please follow following steps for setting the slice size.

Step 1. Please enter your desired value into the blank of the slice size option.



Step 2. After the desired slice size is entered, please press the Apply button  on the bottom of the interface and then the slice size of the BC-50 video is set successfully.

Step 3. Please go back to the “**system**” menu **System** and then click the “**Reboot**” button **Reboot**. Finally, please click the “**Apply**” button **Apply** again and the new setting will be effective.

Please pay attention that the setting items in the Video option for the first stream and second stream are the same. Moreover, for each item in the Video option, the Apply button **Apply** is used to apply the setting that is made by users. The Cancel button **Cancel** is used to discard the change that is made by users.

6.6.4 Image

The “Image” option is the third option on the left column of the BC-50 network control interface which is shown as follows. The items in this “Image option” is used for users to set some image related parameters for the BC-50 video such as Brightness, Saturation, Contrast, Sharpness and Hue.



Please see following paragraphs for details of each item in the Image option.

- **Brightness:** This option allows users to adjust the brightness of the BC-50 video by the slider. The higher value enhances the brightness of the video and the lower value reduces the brightness of the video.
- **Saturation:** This option allows users to adjust the saturation of the BC-50 video. The higher value enhances the saturation of the video and the lower value reduces the saturation of the video.
- **Contrast:** This option allows users to adjust the contrast of the BC-50 video. The higher value enhances the contrast of the video and the lower value reduces the contrast of the video.

- Sharpness: This option allows users to adjust the sharpness of the BC-50 video. The higher value enhances the sharpness of the video and the lower value reduces the sharpness of the video.
- Hue: This option allows users to adjust the hue of the BC-50 video. The higher value enhances the hue of the video and the lower value reduces the hue of the video.

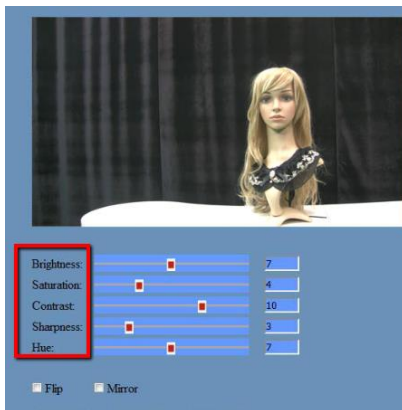



In the Image menu, there is a preview window for users to preview the RTSP streaming video. And users can adjust the image related parameters and preview the adjusted result in this interface. After the Apply button is pressed, the adjustment will be effective.

Please follow following steps for setting the Image option related parameters for the BC-50 video.

Step 1. The adjustment of the image related options including brightness, saturation, contrast, sharpness and Hue must be done by sliders in the image control interface. So, please press the slider for the item that the value must be changed.

Step 2. After that, please drag the slider to the left side to reduce the value of the desired option. Moreover, please drag the slider to the right side to increase the value of the desired option.

Step 3. After the adjustment is done, please press the Apply button  on the bottom of the interface and then the image option related parameters of the BC-50 video are set successfully.

- Flip: The Flip check box  is used for users to flip the video of the BC-50 vertically.
- Mirror: The mirror check box  is used for users to flip the video of the BC-50 horizontally.

Please follow following steps for setting the Flip and Mirror options for the BC-50 video.

Step 1. Please tick the checkbox which is next to the Flip or Mirror option.

Flip Mirror

Step 2. After the desired checkbox is ticked, please press the Apply button  on the bottom of the interface and then the Flip or Mirror parameter of the BC-50 video is set successfully.

Please pay attention that for each item in the Image option, the Apply button **Apply** is used to apply the setting that is made by users. The Cancel button **Cancel** is used to discard the change that is made by users. Moreover, the Default button **Default** is used to restore all image option related parameters to default values.

6.6.5 Audio

The “Audio” option is the fourth option on the left column of the BC-50 network control interface which is shown as follows.



Please see following paragraphs for details of each item in the Audio option.

- **Audio Switch:** This option allows users to switch On/Off the input audio source.

Please follow following steps for setting the Audio Switch for the BC-50 video.

Step 1. Please click the Audio Switch option to show the drop-down menu which is shown as follows.

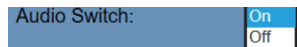

Step 2. Please select your desired option from the drop-down menu.

Step 3. After the desired option is selected, please press the Apply button  on the bottom of the interface and then the Audio Switch option is set successfully.

- **Audio Type:** The default audio type of the BC-50 is AAC audio format which is shown as follows.



- **Sample rate:** This option is used for users to select the input audio sample rate. There are two sample rates including 44.1K and 48K.

Please follow following steps for setting the sample rate for the BC-50 video.

Step 1. Please click the Sample Rate drop-down menu which is shown as follows.



Step 2. Please select your desired option from the drop-down menu.

Step 3. After the desired option is selected, please press the Apply button  on the bottom of the interface and then the sample rate of the BC-50 input audio is set successfully.

- Bit Rate: This option is used for users to set the bit rate of the input audio. Please follow following steps for setting the bit rate for the BC-50 input audio.

Step 1. Please click the Bit Rate drop-down menu which is shown as follows.



Step 2. Please select your desired bit rate value from the drop-down menu.

Step 3. After the desired option is selected, please press the Apply button  on the bottom of the interface and then the bit rate of the BC-50 input audio is set successfully.

- Input Type: The default input type is Line-in. So, it is no need for users to select this option.
- Input Vol L & Input Vol R: If the Line-in is Stereo, this option allows users to adjust the volume of the left channel and the right channel.

Please follow following steps for adjusting the volume of the left channel and the right channel for the BC-50 Line-in.

Step 1. Please click the blank for the Input Vol L or Input Vol R option.

Input Vol L :	<input type="text" value="15"/>	(-97~30) db
Input Vol R :	<input type="text" value="15"/>	(-97~30) db

Step2. Please enter your desired value into the blank of the Input Vol L or Input Vol R.

Step3. After the desired value is entered, please press the Apply button

on the bottom of the interface and then the volume of the left or right input audio source of the BC-50 is set successfully.

- ADTS Option: **Please keep this option Off if the ADTS function is not supported by the decoder.** This AAC ADTS format is suitable for online streaming. If the AAC ADTS is needed for audio decoding, please turn on this option. If there is no need for the ADTS, please keep the option Off.

Please follow following steps for setting the ADTS option for the BC-50 input audio.

Step 1. Please click the ADTS Option drop-down menu which is shown as follows.

ADTS Options:	<input type="button" value="Off"/> <input type="button" value="On"/>
---------------	---

Step 2. Please select your desired option from the drop-down menu.

Step 3. After the desired value is selected, please press the Apply

button on the bottom of the interface and then ATDS operation of the BC-50 input audio is set successfully.

6.6.6 System

The “System” option is the fifth option on the left column of the BC-50 network control interface which is shown as follows.

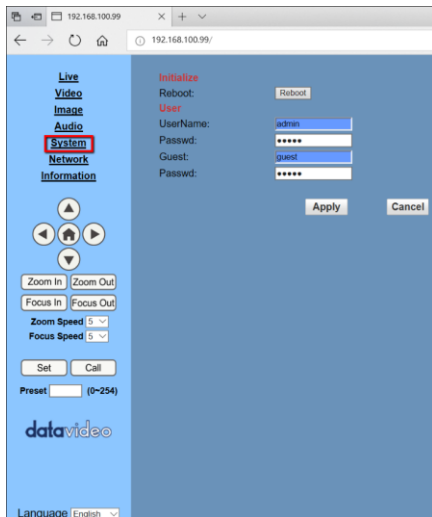

Please see following paragraphs for details of each item in the System option.

- Reboot: The reboot button is used to reboot the BC-50 camera, please follow following steps for rebooting the BC-50. **If any change is made in any item of the “Video” and “Network” menu. Please remember to press the reboot button and then the new setting will be effective.**

Step 1. Please click the reboot button



Step 2. After the reboot button is pressed, please press the Apply button on the bottom of the interface and then the BC-50 will reboot automatically.

- **UserName & Password for users:** This option is for users to set the login user name and password for the BC-50 camera network control interface. The default user name is “admin” and the default password is “admin”. The default user name can not be changed by users. However, users can change the password by themselves. Please follow following steps for modifying the password.

Step 1. Please delete the original password in the blank of the password option.



Step 2. Please enter your desired new password into the blank and then please press the Apply button on the bottom of the interface to set a new user password for the BC-50 camera.

- **UserName & Password for guest:** This option is for users to set the login guest name and password for the BC-50 camera network control interface. The default user name is “guest” and the default password is “guest”. The default user name can not

be changed by users. However, users can change the password by themselves. Please follow following steps for modifying the password.

Step 1. Please delete the original password in the blank of the password option.



Guest: guest

Passwd: ●●●●●

Step 2. Please enter your desired new password into the blank and then please press the Apply button on the bottom of the interface to set a new guest password for the BC-50 camera.

6.6.7 Network

The “Network” option is the sixth option on the left column of the BC-50 network control interface which is shown as follows. Please pay attention that each time the network setting is changed, the BC-50 must be rebooted for applying new setting.

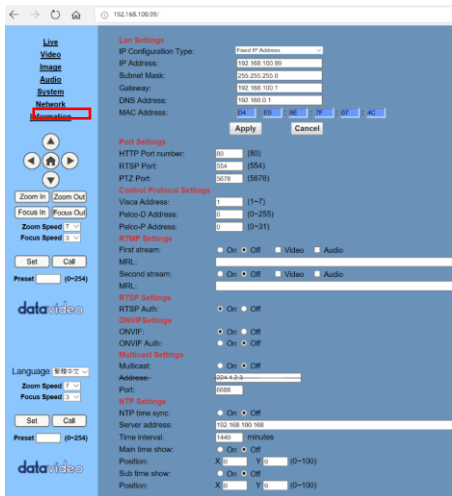

Please see following paragraphs for details of each item in the Network option.

- IP Configuration Type: This option is used for users to set the IP configuration type. The BC-50 provides two types including Fixed IP address and Dynamic IP address.

Please follow following steps for setting the IP configuration type of the BC-50.

Step 1. Please click the drop-down menu of the IP configuration type.



Step 2. Please select your desired IP configuration type from the drop-down menu.

- If the “Fixed IP Address” option is selected, users need to enter the network related parameters including IP Address, Subnet Mask, Gateway and DNS address. The default value of the fixed IP address for the BC-50 is “192.168.100.99”. The Fixed IP address and the Dynamic IP addresses are set by Web UI. However, if the existing BC-50s can not be found from the network, users can press the MENU button on the rear panel of the BC-50 to enter the OSD for looking for the network information. Moreover, users can also press and hold the menu button for about 5 seconds and then plug the DC 12V power to the BC-50 power connector to restore the default fixed IP address: 192.168.100.99.

Lan Settings

IP Configuration Type: Fixed IP Address

IP Address: 192.168.100.99

Subnet Mask: 255.255.255.0

Gateway: 192.168.100.1

DNS Address: 168.95.1.1

MAC Address: D4 : E0 : 8E : 16 : 46 : 9C

Apply Cancel

Step 3. After all addresses are entered, please press the Apply button

 below the MAC address to apply the Fixed IP address setting.

Step 4. Please go back to the “**system**” menu  and then click the

“**Reboot**” button . Finally, please click the “**Apply**” button

 again and the new setting will be effective.

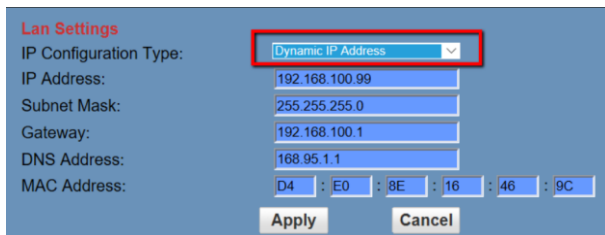

- If the “Dynamic IP Address” option is selected, all related parameters including IP address, subnet mask, Gateway and DNS address will be set by the system automatically.



The screenshot shows a "Lan Settings" dialog box with a blue background. The "IP Configuration Type" dropdown menu is highlighted with a red border and shows "Dynamic IP Address" selected. Below it, the IP Address is 192.168.100.99, Subnet Mask is 255.255.255.0, Gateway is 192.168.100.1, and DNS Address is 168.95.1.1. The MAC Address is displayed as D4 : E0 : 8E : 16 : 46 : 9C. At the bottom, there are "Apply" and "Cancel" buttons.

Please follow following steps for setting the IP configuration type to be Dynamic IP Address.

Step 1. Since all of the IP related parameters are set automatically by the system when choosing the “Dynamic IP Address” option. Please press the Apply button  to set the “Dynamic IP Address” to be the IP configuration type.

Step 2. Please go back to the “**system**” menu  and then click the “**Reboot**” button . Finally, please click the “**Apply**” button  again and the new setting will be effective.

- MAC Address: The MAC address is preset by the system and it is unmodifiable for users.

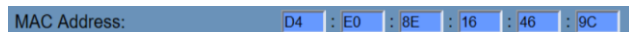

The screenshot shows the MAC Address field with the value D4 : E0 : 8E : 16 : 46 : 9C.

- HTTP Port Number: IP address identifies the network device. The network device can run various web applications. However, network programs use port to transmit data. The data transmission is between ports to ports. The port setting is to determine which port is used by the WEB SERVER for the data transmission. If users need to set the port mapping, please remember that it is a must that the port number must be consistent. The default HTTP Port Number is 80. It's no need for users to modify the port number.

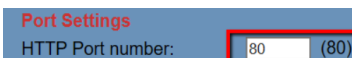

- RTSP Port: The BC-50 Full HD block camera supports RTSP protocol. Please use the VLC tools for broadcasting. The default RTSP Port Number is 554. It's no need for users to modify the port number.



- PTZ Port: The BC-50 Full HD block camera supports PTZ port. The default port is "5678". It's no need for users to modify the port number.



- VISCA Address: This option is used for users to set the VISCA address. The range of the VISCA address is from 1 to 7. The VISCA address in the Web UI is for Web UI setting only. The VISCA setting in the BC-50 OSD is for RS-485 setting only.



Please follow following steps for setting the VISCA address.

Step 1. Please connect a RS-485 to USB adapter cable from the rear panel of the BC-50 to the USB interface of your PC/Laptop.

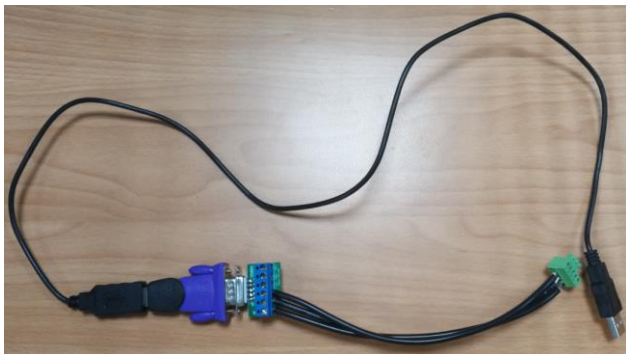







Step 2. Please set your desired VISCA address from the BC-50 homepage control page.

Visca Address: (1~7)

Step 3. After the desired VISCA address is entered, please press the Apply button on the bottom of the interface.

Step 4. After that, please press the Reboot button and then please press the Apply button to reboot the BC-50.

Step 5. Please press the MENU button  and then select the “Setting” option. Please press the MENU button  again to enter the

“Setting” option. After that, please select the “VISCA Addr” option by the Down button  and the next option button . And then, please modify the number of VISCA address to be the same as the one in the homepage control interface by the Down button  and the next option button .



Step 6. After that, users can control the BC-50 by the VISCA commands by related PTZ camera control softwares/hardwares. For example, if the VISCA addresses in the BC-50 homepage control interface and the “VISCA addr” of the MENU are set to be 1. Then the VISCA command format “Tele (Standard) 8x 01 04 07 02 FF” will be “Tele (Standard) 81 01 04 07 02 FF”. The x means the VISCA address 1.

- RTMP Setting: The RTMP setting is used for users to set the RTMP streaming related parameters. For the step by step instruction for the RTMP streaming, please refer to the section **“6.7. How to Live-Stream BC-50’s Video on Live-Streaming Platform-Take Facebook as an Example”**.
- RTSP Auth: The RTSP Auth is used for users to set the RTSP authority. Please follow following steps for setting the RTSP Authority to On.

Step 1. Please click the “On” option of the RTSP Auth option.

RTSP Auth: On Off

Step 2. After the “On” option for the RTSP Auth is selected, please press the Apply button  on the bottom of the interface to set the RTSP Auth option for the BC-50 camera.

Step 3. Please go back to the “system” menu  and then click the “Reboot” button . Finally, please click the “Apply” button  again and the new setting will be effective.

Step 4. Please open the VLC media player which is shown as following diagram.

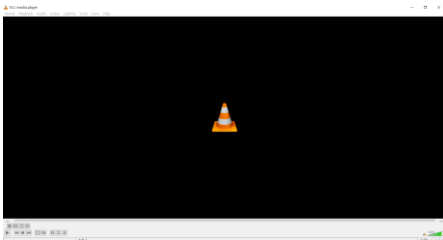

Step 5. Please click the “Open Network Stream” option by clicking the Media drop-down menu.

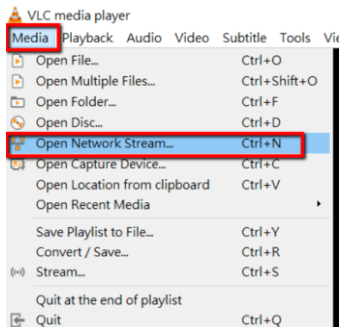

Step 6. After the network setting window is shown, please enter the RTSP streaming URL into the blank and then please press the “Play” button.

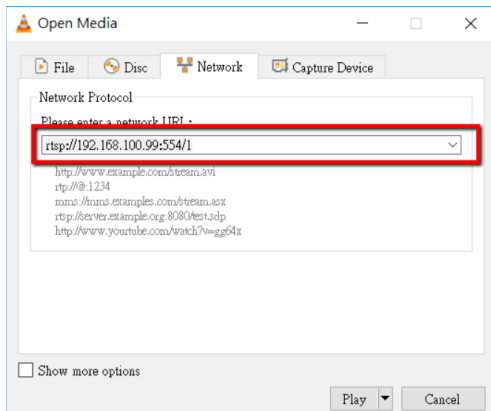

Step 7. After that, a dialogue window is shown for users to enter the Username and Password. Please enter the default user name “admin” and default password “admin” into the blanks. Finally, please press the “OK” button.

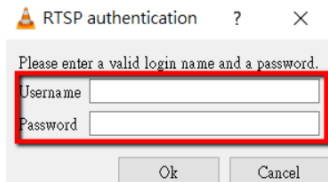

Step 8. Users can see the RTSP streaming screen from the VLC media player.

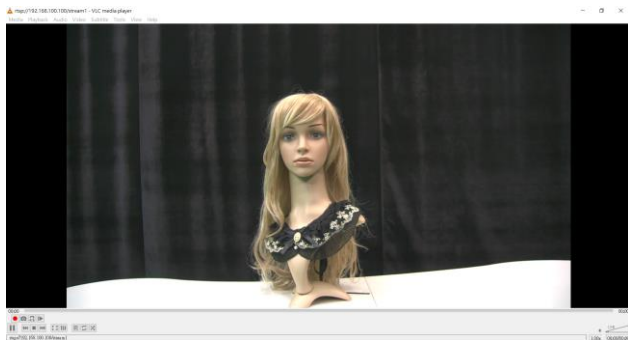





- ONVIF: The ONVIF (Open Network Video Interface Forum) is a global open standard for developing the standard network interface of the internet video products such as IP cameras and PTZ cameras.

Please follow following steps for setting the ONVIF settings.

Step 1. Please click the “On” option of the ONVIF option.



Step 2. After the “On” option for the ONVIF is selected, please press the Apply button  on the bottom of the interface to set the ONVIF option.

Step 3. Please go back to the “**system**” menu  and then click the “**Reboot**” button . Finally, please click the “**Apply**” button  again and the new setting will be effective.

Step 4. Please download the free software “ONVIF Device Manager” from the website

https://sourceforge.net/projects/onvifdm/?source=typ_redirect



Step 5. After the download is finished, please double-click the installation file to install this software.

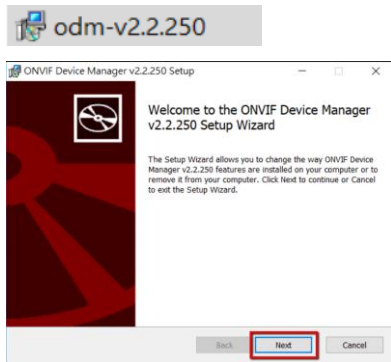

Step 6. After the installation is finished, please open the software and then enter the User name “admin” and the password “admin” into the blanks. After that, please click the log in button.



Step 7. After the login is completed, users can see address and firmware information on the left side of the screen. Please click the area inside the red box.

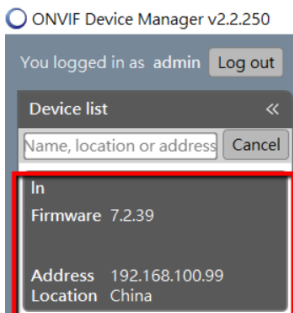

Step 8. Please click the Application settings on the top right corner of the screen to set the video streaming transport as the UDP from the drop down menu.

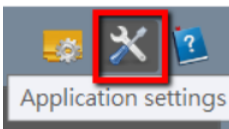

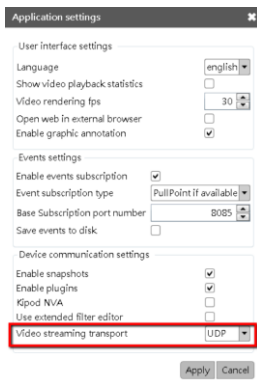

Step 9. After that, Please click the Live video option from the NVT section and then users can see the BC-50 live video.

- ONVIF Auth: This option is used to turn on/off the ONVIF authority. Please follow following steps for setting the ONVIF Auth.

Step 1. Please click “On” or “Off” option for turning on/off the ONVIF Auth option.



Step 2. After the “On”, “Off” is selected, please press the Apply button



to “set the ONVIF Auth option.

Step 3. Please go back to the “**system**” menu **System** and then click the “**Reboot**” button **Reboot**. Finally, please click the “**Apply**” button **Apply** again and the new setting will be effective.

- Multicast: Multicast option is used for users to turn on/off the multicast function. Multicast is group communication where data transmission is addressed to a group of destination computers simultaneously.

Multicast: On Off

- Address: This option is the multicast address. It is a default value.

Address:

- Port: This is the port for the multicast. It is a default value.

Port:

Please follow following steps for setting the Multicast option.

Step1. Please set the Multicast setting to “On”.

Multicast: On Off

Step 2. After the “On” option for the Multicast is selected, please press the Apply button **Apply** on the bottom of the interface to activate the Multicast option.

Step 3. After that, please press the reboot button **Reboot** in the System option and then please press the Apply button **Apply** for rebooting the BC-50.

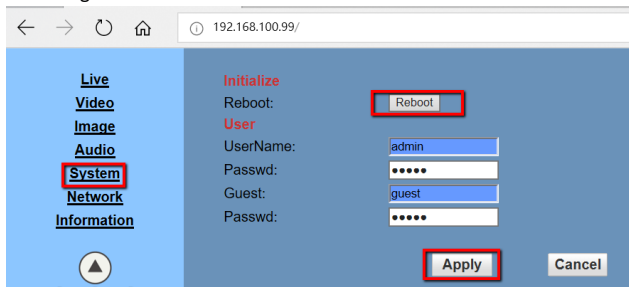

Step 4. After the BC-50 is rebooted, please open the VLC media player and then please click “Open Network Stream” from the “Media” drop-down menu.

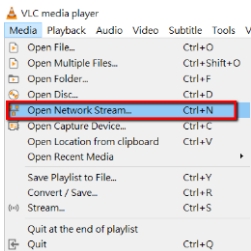

Step 5. Please enter the default multicast address in the format of “rtp://224.1.2.3:6688”. After that, please click the “Play” button for playing the multicast image.

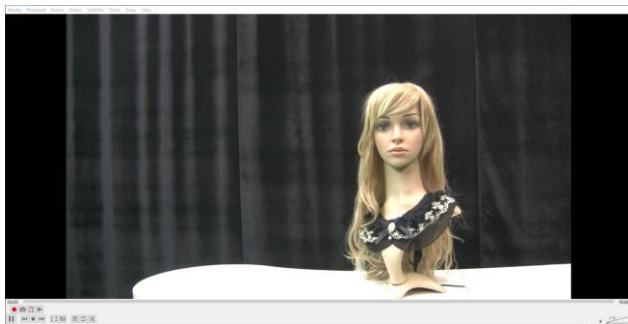
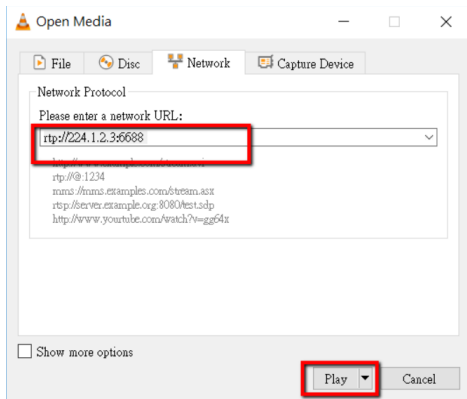

- NTP time sync: The NTP time sync is used for the automatic Network Time Precision Setting. Please follow following steps for setting the NTP time sync option.

Step 1. Click the NTP “On” or “Off” option.



Step 2. After the “On”, “Off” is selected, please press the Apply button



Step 3. Please go back to the “system” menu **System** and then click the

“Reboot” button **Reboot**. Finally, please click the “Apply” button

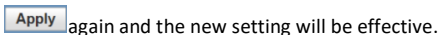

- Server address and Time interval: This server address and Time interval is for NTP that can help users for precision time calibration. Users can find NTP server address through the Internet for this setting. In this example, the server address is clock.stdtime.gov.tw If the device is connected to the network then the time will be calibrated automatically.



- Main Time Show & Position: This option is used for users to adjust the position of the main time. Users can adjust the X & Y values to adjust the position of the OSD. The value (0,0) represents the top left position and the value(100,100) is the bottom right position.

Main time show: On Off
Position: X Y (0~100)

Please follow following steps for setting the main time position.

Step 1. Please enter your desired X and Y values into the blanks for the Position option. The range of the value must be within 0~100.

Step 2. After the desired X and Y values are entered, please press the Apply button to “set the Main time show on/off and main time position.



Step 3. Please go back to the “**system**” menu and then click the “**Reboot**” button . Finally, please click the “**Apply**” button again and the new setting will be effective.

- Sub Time Show & Position: This option is used for users to adjust the position of the sub time. Users can adjust the X & Y values to adjust the position of the OSD. The value (0,0) represents the top left position and the value(100,100) is the bottom right position.
- Please follow following steps for setting the main time position.

Sub time show: On Off
Position: X Y (0~100)

Step 1. Please enter your desired X and Y values into the blanks for the Position option. The range of the value must be within 0~100.

Step 2. After the desired X and Y values are entered, please press the Apply button  to “set the Sub time show on/off and main time position.

Step 3. Please go back to the “**system**” menu  and then click the “**Reboot**” button . Finally, please click the “**Apply**” button  again and the new setting will be effective.

6.6.8 Information

The “Information” option is the seventh option on the left column of the BC-50 network control interface which is shown as follows. There are four items will be shown in the information option including Device ID, Software Version, Device Type and Webware Version. However, the Device ID is the only item that can be changed by users.







Please follow following steps for modifying the Device ID.

Step 1. Please delete the original Device ID and then please enter your desired device ID into the blank.

Step 2. After the desired device ID is entered, please press the Apply button  to “set the new Device ID as the default value.

6.6.9 Control Buttons on the Left Column of the Network Control Interface

There are several buttons on the left column of the network control interface including Menu(confirm), Up, Down, Next Option, Previous Option, Zoom In, Zoom Out, Focus In, Focus Out, Set and Call buttons. The functions of the Home, Up, Down, Next option and Previous option are equal to buttons on the rear panel of the BC-50 camera.

Button	Function
	This is the MENU/confirm button. Users can press the MENU button to show the MENU. If any option of the menu is selected, users can press this button to confirm the selection.
	This is the Up button. Users can use this key to move up to any option
	This is the Down button. Users can use this key to move down to any option
	This is the Left button(previous option button). When entering into MENU, users can go to previous option by this button.
	This is the Right button(Next option button). When entering into MENU, users can go to next option by this button.

- Zoom Speed: This option is used to set the Zoom Speed of the BC-50 camera. Higher value means faster speed and lower value means slower speed.

Please select your desired Zoom speed from the Zoom Speed drop-down menu. After the speed is selected, the new setting is effective.

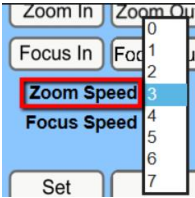

- Focus Speed: This option is used to set the Focus Speed of the BC-50 camera. Higher value means faster speed and lower value means slower speed.

Please select your desired Focus speed from the Focus Speed drop-down menu. After the speed is selected, the new setting is effective.

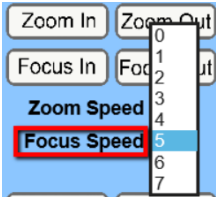

- Zoom In: This Zoom in button Zoom In helps users for zooming in.
- Zoom Out: This Zoom out button Zoom Out helps users for zooming out.
- Focus In: This Focus In button Focus In helps users for focusing in.

- Focus Out: This Focus Out button  helps users for focusing out.
- Preset: Users can set the desired Zoom In/Zoom Out and Focus In/Focus Out point in advance. After that, users can set those desired Zoom and Focus points as presets. Once a pre-saved preset is set, users can call it out if it is needed. Please see following steps **for setting the preset**.

Step 1. Please adjust the Zoom and Focus points in advance.

Step 2. After the desired Zoom and Focus points are adjusted, please enter the desired number in the preset blank.

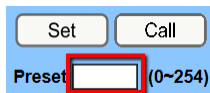

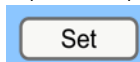

Step 3. Please press the “Set” button to save the preset.

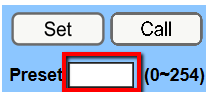

Please see following steps **for calling the preset**.

Step 1. Please enter the pre-saved preset number in the preset blank.



Step 2. After that, please press the “Call” button  and then the desired preset is shown.

6.6.10 Download the Network Upgrade Program

The latest version firmware and software are already uploaded to the Datavideo official website. Please visit the Datavideo official website <https://www.datavideo.com/product/BC-50> for downloading the latest firmware and software of the BC-50 block camera.

6.7. How to Live-Stream BC-50's Video on Live-Streaming Platform- Take Facebook as an Example

At first, users must confirm whether the BC-50's IP address is set in DHCP mode. If the IP address is set in DHCP mode, then you can skip this paragraph, if the IP address is set in manual mode, what you have to do is to set the BC-50 and your PC or laptop in the same Local Area Network(LAN).

1. Please connect the BC-50 Full HD block camera to your PC or Laptop via the Ethernet cable.
2. Please press the **MENU** key on the rear panel of the BC-50 when the BC-50 is turned on to enter the main menu.
3. Please press the **Down** key to select the option "information", and then press the **MENU** key to enter into this option.

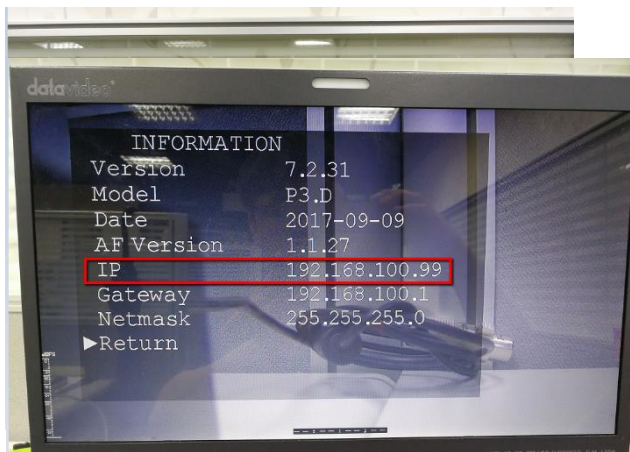

4. After entering the option, users can see the default IP address of the BC-50.
5. Please open your web browser and input BC-50's IP address" in the address bar to enter BC-50's web-page control interface.



6. A pop-up window will appear and ask you to input the user name and password. Please input the default user name "admin" and the default password "admin". After that, you can enter the BC-50 web-page control interface.



7. Please select the “Network” option.



8. In the LAN Setting section, please select the option “Dynamic IP Address” in the drop-down menu of IP Configuration Type.

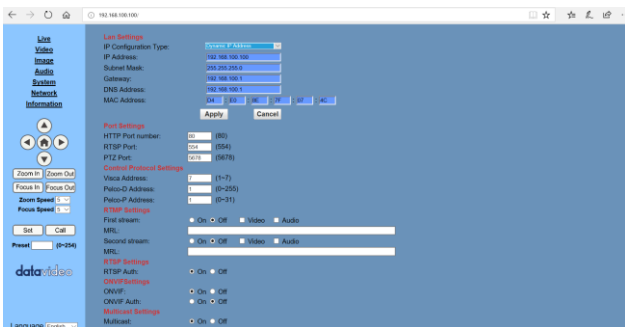

9. Please press the button **“Apply”** to apply the setting.

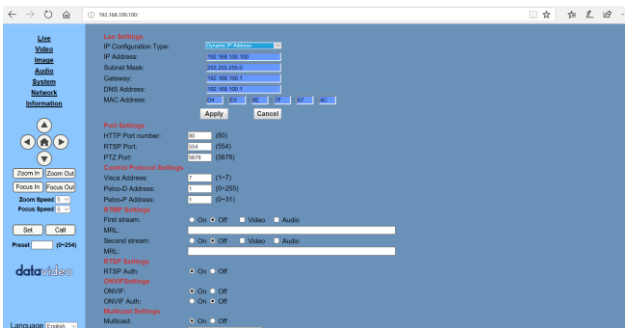

10. Please connect the Ethernet cable that is connected to the fixed network to the WAN port of the router.

11. After that, please connect the Ethernet cables that are connected to the BC-50 and the PC to your routers.

12. On the desktop of the Windows computer, please select the **“Network Connections”** option as shown in following diagram.



13. Please select the **Ethernet** option.

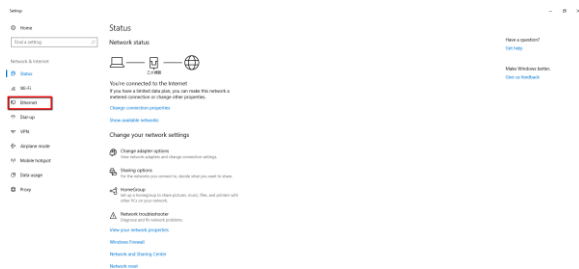

14. Select the item “**Change adapter options**”.



15. Select the Ethernet icon, click mouse's right button and then select "Properties"

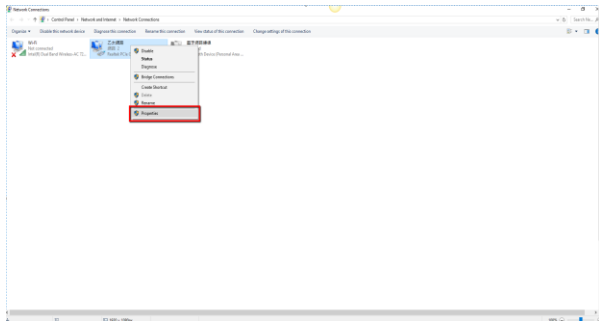

16. Please select the "(TCP/IPv4)", and then press "Properties"

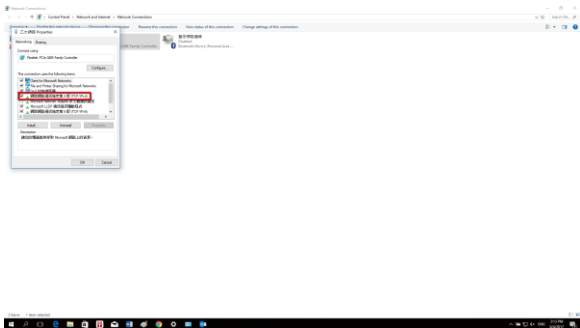

17. Please select “**Obtain an IP address automatically**”, and then press **OK**.

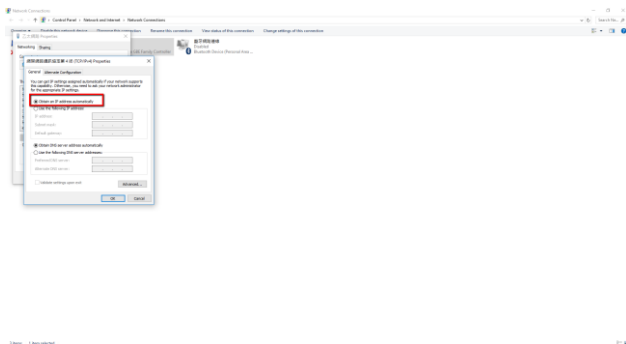

18. Please unplug and then re-plug the power cable of the BC-50 to resume the BC-50.

19. Please press the “**MENU**” key on the rear panel of the BC-50 to show the main menu and select the “**Information**” option to enter into it and to check the IP address of the BC-50.

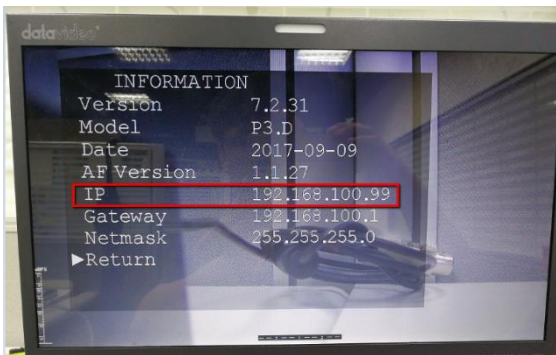

20. Please open the web browser and then input the BC-50 default IP address in the address bar.



21. A pop-up window will appear and ask users to input the user name and password. Please enter the default user name “admin” and the default password “admin” to reach the BC-50 web-page control interface.



22. Please get the “streaming server address” and “streaming name/key” in advance from the live-streaming platform that you want to live-stream.

23. Take Facebook as an example. Please follow the steps below.

- Step1. Please go to the website <https://www.facebook.com/live/create>.
- Step2. Please click “**Create Live Stream**” as follows.

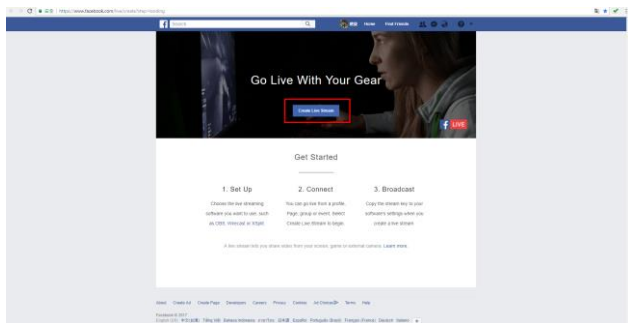

- Step3. Please choose where you want your live stream to appear including your timeline, a friend's timeline, in a group or in an event and then click **“Next”**.

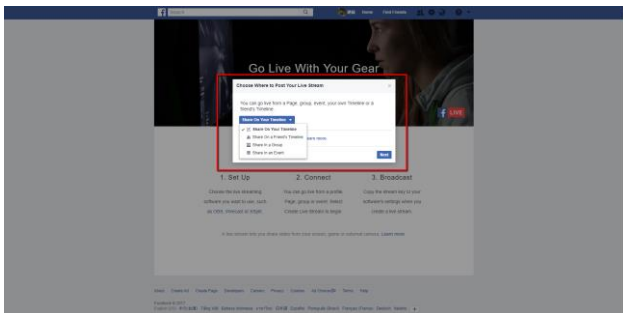

- Step4. Please copy the server URL and the stream key from the screen as shown as follows.

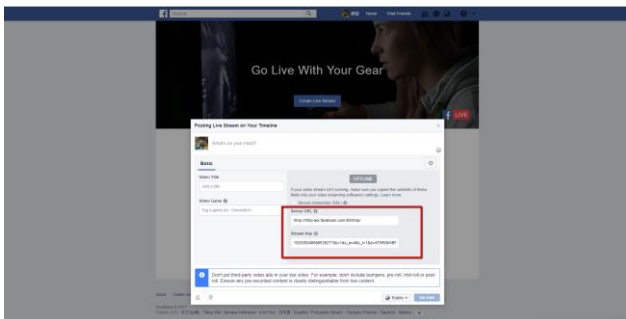

- Step5. Please paste the server URL and the stream key into the MRL of the first stream in the BC-50 web-page control interface as shown as follows. And please remember to select the “On” option. Moreover, the “Audio” and “Video” options for the first stream must be ticked. For the second stream, the setting method is the same as the first stream if it is needed.



- Step 6. Please click “Apply” button on the bottom of the screen.

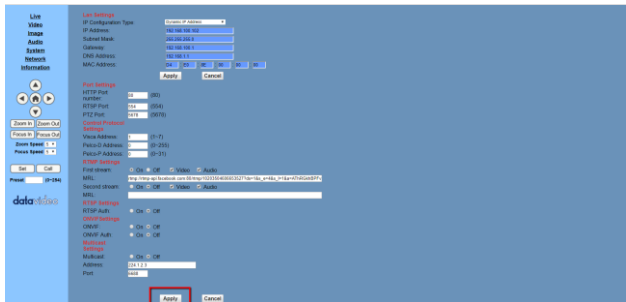

- Step 7. Select the **System** option and then click the “**Reboot**” button to reboot the BC-50.

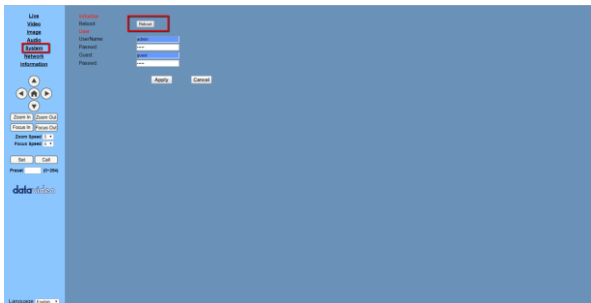

- After the BC-50 reboot, you can see the live-stream preview screen as shown as follows. Just click the “**Go Live**” button, then the real-time video of the BC-50 can be live-streamed to your Facebook page as you wish.

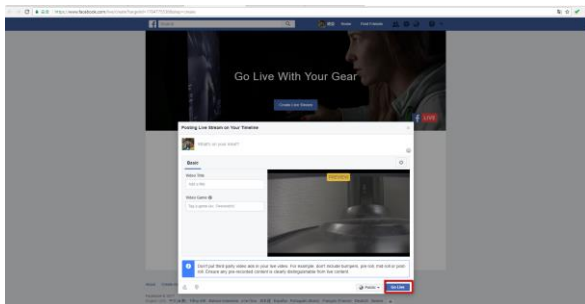

7. Maintenance & Warnings

7.1. Maintenance

In order to prevent the BC-50 Full HD block camera from broken, there are some tips or reminders for users to keep in mind about the maintenance and troubleshooting of the BC-50 Full HD block camera.

- **Maintenance of the BC-50 Full HD Block Camera**
If the BC-50 Full HD block camera is not used for a long time, please remember to disconnect the power cable from the BC-50, so that the BC-50 can be turned off completely for safety consideration. At the same time, please remember to disconnect the power adapter from the AC socket. For storing the BC-50, please remember to clear the dust on the camera housing by soft cloth or cotton paper. If users want to clean the camera lens, please remember to use dry soft cloth for wiping. If the BC-50 is very dirty, please use neutral detergent to wipe gently. DO NOT use strong or corrosive cleaner so as to avoid the lens scratches to affect the image quality.
- **Avoid Camera Operation in the Environment that Exceeds its Maximum Intensity of Illumination**
The BC-50 Full HD Block camera may not achieve its best image quality if it is operated in the environment that the maximum intensity of illumination exceeds the tolerance of the BC-50 Full HD block camera.
- **Avoid Using the BC-50 for Following Situation**
Users should avoid shooting for ultra-bright objects such as sunshine and lamplight, etc. Please remember that do not use the BC-50 Full HD block camera in unstable lighting environment or it may cause flashing image condition.

- **Do Not Use the BC-50 near Facilities with High Power Radio Waves**

Please remember that the BC-50 Full HD Block camera can not be used near facilities that will generate high power radio waves such as television station and radio transmitter, etc.

8. Failures & Troubleshooting

Image	
Failures	Troubleshooting Steps
Display shows no image	<ol style="list-style-type: none">1. Check whether the camera power supply is connected correctly2. Check whether the supply voltage is correct3. Check whether the power light is lit.4. Check whether the SDI cables are connected correctly.5. Check the manual lens aperture and open the aperture.
Sometimes there is no image	<ol style="list-style-type: none">1. Check whether the SDI cables are connected correctly.2. Check whether the camera is installed stably and please assure that there is no strong shock.
Image Blurring	<ol style="list-style-type: none">1. Check whether the focus of the camera lens is accurate.2. Check whether the surface of the lens is clean.
Control	
Camera can't be controlled by the serial port	<ol style="list-style-type: none">1. Check whether the camera control parameter is set correctly.2. Check whether the control wire is connected correctly.

9. Dimensions

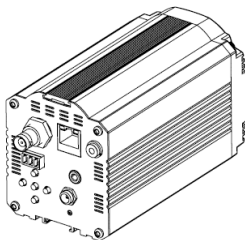
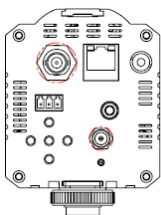
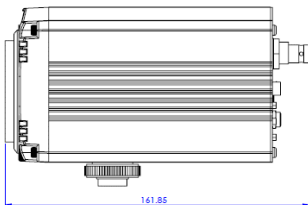
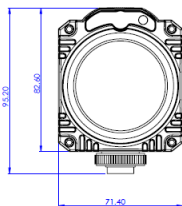
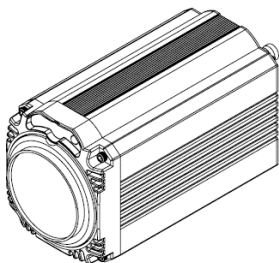

All measurements in millimeters (mm)

10. Frequently-Asked Questions

This section describes problems that you may encounter while using the BC-50. If you have questions, please refer to related sections and follow all the suggested solutions. If problem still exists, please contact your distributor or the service center.

No	Problems	Solutions
1.	It takes a lot of time for the white balance calibrating. How long does it take to complete the white balance calibrating?	It takes about 10 seconds for calibrating the white balance.
2.	Why the streaming cannot be resumed by setting the Web UI after the streaming is terminated?	When the streaming is terminated, it is needed to reboot the BC-50 to resume the streaming.
3.	Why the new setting does not take effect after setting by the web-based user interface?	The BC-50 must be rebooted after making any modification.
4.	How long does it take to boot the BC-50	It takes about 10 seconds for booting the BC-50.

5.	How many frame delay does the BC-50 have for its SDI output?	There are 3 frame delays for the BC-50
6.	When users preview the streaming by the Google Chrome web browser, the warning “This plug-in is not supported” will appear and the VLC download option can not be found. However, this issue will not be happened when using the IE web browser.	The recommended browser for the Web UI is the Internet Explorer or the Firefox browser which the version is prior to 51.0.1. It’s not recommended to use the Google Chrome.
7.	What is the specification of the Audio in.	The spec. of the Audio in is the line in level rather than the Mic in. This audio signal can output with the streaming. However, it cannot be embedded to the SDI output.
8.	How to use PoE?	Please buy a PoE switch or PoE router in advance. When you are using PoE, please remember to connect the PoE cable only and

		<p>not to connect the SDI cable, DC12V power cable, the RS-485 cable and tally light simultaneously. The PoE function can be used only in IP CAM mode.</p>
<p>9</p>	<p>How to find the network related information in BC-50 OSD?</p>	<p>Those network related information can be found in BC-50 MENU. At first, please make sure all Ethernet and power related cables are connected correctly. Next, please press the MENU button for entering the MENU OSD. And then, please select the Information option and press the MENU button to enter into it. In the main page of the information option, users can see all Ethernet related parameters of the BC-50.</p>

11. Specifications

Model Name	BC-50
Product Name	IP Block Camera
Video Format	1080p 60/50/30/25 1080i 60/50 720p 60/50
Image Sensor	1/2.7" progressive scan CMOS sensor
Effective Pixels (approx.)	2.07 Mega pixels
S/N Ratio	55dB
Min. Illumination	0.05 Lux @ (F1.8, AGC ON)
Electronic Shutter	1/30s ~ 1/10000s
Zoom Ratio	20x Optical zoom ; 16x Digital zoom
Gamma Control	Yes
Iris Control	Auto/Manual
Digital Noise Reduction	2D & 3D

On-Screen Display (OSD)	English, Simplified Chinese, Traditional Chinese
White Balance	Auto, 3000K/Indoor, 4000K, 5000K/Outdoor, 6500K_1, 6500K_2, 6500K_3, One Push, Manual
AGC/Gain Control	Auto / Manual (0 to 28 step) Max. Gain Limit (6 to 28 step)
Mirror/Flip Image	Yes
Focus Mode	Auto / Manual
Panning/Tilting Range	N/A
Panning/Tilting Speed	N/A
Preset	N/A
Field of View (Horizontal, Wide)	Approx. 63.7° (WIDE END) / 2.3° (TELE END)
Image Compensation	Day & Night function
Image Output	3G/HD-SDI x1
Tally LED	Dual color (Red, Green)
Filter	M52.0 x 0.75 Thread with UV Protection

ROHS	Compliant
Protocol	VISCA, Pelco-D, Pelco-C
Remote Control Interface and Transmit Distance	RS-485: Transmit up to 1000m
F/W Update	Ethernet
IR Control	N/A
Camera Control Unit	N/A
Size of Screw Hole for Tripod	Use hot shoe mount
Options	PTR-10 Robotic Pan Tilt Head
Color	Dark Blue
Lens	
Angle of View (Vertical)	34.1 degrees to 1.89 degrees
Backlight Compensation	Supported
Power over Ethernet	Supported

IP Camera Features	
Video Compression Format	H.265/H.264/MJPEG
Video Stream	first stream & second stream
First Stream Resolution	1920x1080, 1280x720, 1024x576, 960x540, 640x480, 640x360
Second Stream Resolution	1280x720, 1024x576, 720x576, 720x408, 640x360, 480x270, 320x240, 320x180
Video Bit Rate	32Kbps ~ 20480Kbps
Bit Rate Type	Variable Rate, Fixed Rate
Frame Rate	50Hz: 1fps ~ 50fps 60Hz: 1fps ~ 60fps
Audio Compression Format	AAC
Audio Bit Rate	96Kbps, 128Kbps, 256Kbps
Protocols Supported	TCP/IP, HTTP, RTSP, RTMP, DHCP, Multicast, etc.
Control/Input & Output Interface	

HD Output	1x3G-SDI: BNC type, 800mVp-p, 75Ω, Along to SMPTE 424M standard
Network Interface	1xRJ45:10M/100M adaptive Ethernet ports
Audio interface	1x Stereo 3.5mm audio interface, Line- In
Others	
Power Connector	DC Jack w/Lock
Reset Button	Supported (Web UI)
Input Voltage	DC 12V
Current Consumption	0.5A (Max)
Operating Temperature	0°C ~ 40°C (32°F ~ 104°F)
Storage Temperature	-40°C ~ 60°C (-40°F ~ 140°F)
Power Consumption	6W (Max)
Ceiling Installation	Supported
Dimensions (W x H x D)	71.4mm x 95.20mm x 161.85mm (w/ tripod mount)

	71.4mm x 82.60mm x 161.85mm (w/o tripod mount)
Net Weight	0.706Kg (w/ tripod mount)

Note

Note

Note

Service & Support

It is our goal to make your products ownership a satisfying experience. Our supporting staff is available to assist you in setting up and operating your system. Please refer to our web site www.datavideo.com for answers to common questions, support requests or contact your local office below.

China Shanghai
Datavideo Technologies China Co
601 Building, 10, No. 1228,
Rd. Jiangchang,
Jingan District, Shanghai
Tel: +86 21-5603 6599
Fax: +86 21-5603 6770
E-mail: service@datavideo.cn

China Beijing
Datavideo Technologies China Co
No. 812, Building B, Wankai Center,
No.316, Wan Feng Road, Fengtai District,
Beijing, China
Tel: +86 10-8586 9034
Fax: +86 10-8586 9074
E-mail: service@datavideo.cn

China Chengdu
Datavideo Technologies China Co
B-523, Meilian square, No. 1386,
Middle of Tianfu Avenue, Gaocun District,
Chengdu, Sichuan
Tel: +86 28-8613 7786
Fax: +86 28-8513 6486
E-mail: service@datavideo.cn

China Fuzhou
Datavideo Technologies China Co
A1-2318-19 Room, No.8, Aojiang Road,
Tajiang District, Fuzhou, Fujian, China
Tel: 0591-83211756 + 0591-83210187
Fax: 0591-83211262
E-mail: service@datavideo.cn

China Jinan
Datavideo Technologies China Co
902, No. 1 business building,
Xiangtai Square, No. 129,
Yingshionshan Road, Shizhong District,
Jinan City, Shandong Province, China
Tel: +86 531-8607 8813
E-mail: service@datavideo.cn

Hong Kong
Datavideo Hong Kong Ltd
G/F, 26 Cross Lane
Wanchai, Hong Kong
Tel: +852-2833-1981
Fax: +852-2833-9916
E-mail: info@datavideo.com.hk

India Noida
Datavideo India Noida
A-132, Sec-63, Noida-201307,
India
Tel: +91-0120-2427337
Fax: +91-0120-2427338
E-mail: sales@datavideo.in

India Kochi
Datavideo India Kochi
2nd Floor- North Wing, Govardhan Building,
Opp. NCC Group Headquarters, Chittoor Road,
Cochin- 682035
Tel: +91 4844-025336
Fax: +91 4844-047696
E-mail: sales@datavideo.in

Netherlands
Datavideo Technologies Europe BV
Flionsdreef 106
3565 AM Utrecht,
The Netherlands
Tel: +31-30-2619856
Fax: +31-30-2619657
E-mail: info@datavideo.nl

Singapore
Datavideo Visual Technology(S) Pte Ltd
No. 178 Paya Lebar Road #06-07
Singapore 409030
Tel: +65-6749 6866
Fax: +65-6749 3266
E-mail: info@datavideovirtualset.com

Singapore
Datavideo Technologies (S) PTE Ltd
No. 178 Paya Lebar Road #06-03
Singapore 409030
Tel: +65-6749 6866
Fax: +65-6749 3266
E-mail: sales@datavideo.sg

Taiwan
Datavideo Technologies Co. Ltd
10F, No. 176, Jian 1st Rd., Chung Ho
District, New Taipei City 235, Taiwan
Tel: +886-2-3227-2888
Fax: +886-2-3227-2777
E-mail: service@datavideo.com.tw

United States
Datavideo Corporation
7349 Elmer Avenue,
Whittier, CA 90602,
U.S.A.
Tel: +1-562-696 2324
Fax: +1-562-698 6930
E-mail: sales@datavideo.com

United Kingdom
Datavideo UK Limited
Brookfield House, Brookfield Industrial
Estate, Peakdale Road, Glossop,
Derbyshire, SK13 6LQ
Tel: +44-1457 851 000
Fax: +44-1457 850 964
E-mail: sales@datavideo.co.uk

France
Datavideo France s.a.r.l.
Cité Descaries 1, rue Albert Einstein
Champs sur Marne 77477 -
Marne la Vallée cedex 2
Tel: +33-1-60370246
Fax: +33-1-60376732
E-mail: info@datavideo.fr



Please visit our website for latest manual update.
www.datavideo.com/product/BC-50

datavideo

www.datavideo.com

All the trademarks are the properties of their respective owners.
Datavideo Technologies Co., Ltd. All rights reserved 2018