

PAR 2 CT Zoom

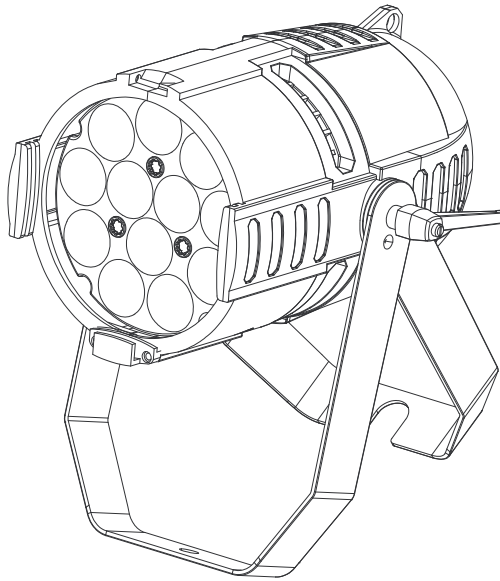

User Manual



© 2013-2015 Martin Professional ApS. Information subject to change without notice. Martin Professional and all affiliated companies disclaim liability for any injury, damage, direct or indirect loss, consequential or economic loss or any other loss occasioned by the use of, inability to use or reliance on the information contained in this manual. The RUSH logo, the RUSH name, the Martin logo, the Martin name and all other trademarks in this document pertaining to services or products by Martin Professional or its affiliates and subsidiaries are trademarks owned or licensed by Martin Professional or its affiliates or subsidiaries.

Martin Professional • Olof Palmes Allé 18 • 8200 Aarhus N • Denmark • www.martin.com

Manual: Revision D

Table of contents

Safety information	4
Introduction	9
Before using the product for the first time	9
Physical installation	10
Fastening the fixture to a flat surface	10
Mounting the fixture on a truss	10
Securing with a safety cable	11
AC power	11
Linking fixtures to power in a chain	12
Fixture overview	13
Control data link	14
Tips for reliable data transmission	15
Connecting the DMX data link	15
Fixture setup	15
Using the control menus	15
DMX addressing	16
Dimming curves	16
Blackout or Hold if DMX signal stops	17
Display panel backlight sleep mode	17
Dimmer speed	17
Fixture test	18
Cooling fan options	18
Single standalone scene	19
Fixture information	19
Reset	19
Effects	20
Maintenance	21
Cleaning	21
Fuse replacement	22
Service and repairs	22
DMX protocol	23
Control menus	24
Troubleshooting	25
Specifications	26

Safety information



WARNING!

Read the safety precautions in this manual before installing, operating or servicing this product.

The following symbols are used to identify important safety information on the product and in this manual:



Warning!

Safety hazard. Risk of severe injury or death.



Warning!

Powerful light emission. Risk of eye injury.



Warning!

See user manual for important safety information.



Warning!

Hazardous voltage. Risk of lethal or severe electric shock.



Warning!

Hot surfaces and fire hazard.



Warning! Risk Group 2 product according to EN 62471. Do not look directly into the beam. Do not view the light output with optical instruments or any device that may concentrate the beam.

This lighting fixture is for professional use only and must be installed by a qualified technician. It is not for household use. It presents risks of severe injury or death due to fire hazards, electric shock and falls. It produces a powerful, concentrated beam of light that can create a fire hazard or a risk of eye injury if the safety precautions below are not followed.



Install, operate and service RUSH by Martin™ products only as directed in their user manuals, or you may create a safety hazard or cause damage that is not covered by product warranties.

Follow the safety precautions listed below and observe all warnings in this manual and printed on the product. Keep this user manual for future use.

For the latest user documentation and other information for this and all Martin™ products, please visit the Martin website at <http://www.martin.com>

If you have any questions about how to install, operate or service the fixture safely, please contact your Martin™ distributor (see www.martin.com/distributors for details) or call the Martin™ 24-hour service hotline on +45 8740 0000, or in the USA on 1-888-tech-180.

Respect all locally applicable laws, codes and regulations when installing, operating or servicing the fixture.



Protection from electric shock

Do not expose the fixture to rain or moisture.

Disconnect the fixture from AC power before carrying out any installation or maintenance work and when the fixture is not in use.

Ensure that the fixture is electrically connected to ground (earth).

Use only a source of AC power that complies with local building and electrical codes and has both overload and ground-fault (earth-fault) protection.

Socket outlets or external power switches used to supply the fixture with power must be located near the fixture and easily accessible so that the fixture can easily be disconnected from power.

Replace defective fuses with ones of the specified type and rating only.

Isolate the fixture from power immediately if the power plug or any seal, cover, cable, or other component is damaged, defective, deformed, wet or showing signs of overheating. Do not reapply power until repairs have been completed

Before using the fixture, check that all power distribution equipment and cables are in perfect condition and rated for the current requirements of all connected devices.

Use only Neutrik PowerCon cable connectors to connect to the fixture's power sockets.

Do not connect devices to power in a chain that will exceed the electrical ratings of any cable or connector used in the chain.

The supplied power input cable is rated 6 A and can safely supply only one fixture with mains power. Do not connect any device to the fixture's MAINS OUT connector when using this cable. If you replace this cable and also use the replacement cable to supply only one fixture with mains power, the replacement cable must also be rated 6 A minimum, have three conductors 18 AWG or 0.75 mm² minimum conductor size, have an outer cable diameter of 6 - 15 mm (0.2 - 0.6 in.) and be temperature-rated to suit the application. In the USA and Canada the cable must be UL listed, type SJT or equivalent. In the EU the cable must be type H05VV-F or equivalent.

To connect fixtures to mains power in a chain, you must first obtain 14 AWG or 1.5 mm² power input and throughput cables that are 16 A rated and temperature-rated to suit the application. In the USA and Canada the cables must be UL-listed, type SJT or equivalent. In the EU the cables must be type H05VV-F or equivalent. Suitable cables with Neutrik PowerCon connectors are available from Martin™ (see 'Accessories' on page 28). If you use these cables, you can connect fixtures to power in a linked chain, MAINS OUT throughput socket to MAINS IN input socket, but do not link more than:

- eight (8) RUSH PAR 2 fixtures in total at 100-120 V, or
- eighteen (18) RUSH PAR 2 fixtures in total at 200-240 V.

The voltage and frequency at the MAINS OUT socket are the same as the voltage and frequency applied to the MAINS IN socket. Only connect devices to the MAINS OUT socket that accept this voltage and frequency.



Protection from burns and fire

Do not operate the fixture if the ambient temperature (T_a) exceeds 40° C (104° F).

The surface of the product casing can reach up to 60° C (140° F) during operation. Avoid contact by persons and materials. Allow the fixture to cool for at least 15 minutes before handling.

Keep flammable materials well away from the fixture. Keep all combustible materials (e.g. fabric, wood, paper) at least 100 mm (4 in.) away from the fixture housing.

Ensure that there is free and unobstructed airflow around the fixture. Provide a minimum clearance of 100 mm (4 in.) around fans and air vents.

Do not use the fixture to illuminate surfaces within 200 mm (8 in.) of the fixture.

Do not attempt to bypass thermostatic switches or fuses.

Do not stick filters, masks or other materials onto any optical component.

The fixture's lenses can focus the sun's rays, creating a risk of fire and damage. Do not expose the front of the fixture to sunlight or any other bright light source.



Protection from eye injury

Do not stare directly into the product's light output.

Do not look at the light output with magnifiers, telescopes, binoculars or similar optical instruments that may concentrate the light output.

Ensure that persons are not looking directly into the front of the fixture when the product lights up suddenly. This can happen when power is applied, when the product receives a DMX signal, or when certain control menu items are selected.

To minimize the risk of eye irritation or injury, disconnect the fixture from power at all times when the fixture is not in use, and provide well-lit conditions to reduce the pupil diameter of anyone working on or near the fixture.



Protection from injury

Fasten the fixture securely to a fixed surface or structure when in use. The fixture is not portable when installed.

Ensure that any supporting structure and/or hardware used can hold at least 10 times the weight of all the devices they support.

If suspending from a rigging structure, fasten the fixture to a rigging clamp. Do not use safety cables as the primary means of support.

If the fixture is installed in a location where it may cause injury or damage if it falls, install as directed in this manual a secondary attachment such as a safety cable that will hold the fixture if a primary attachment fails. The secondary attachment must be approved by an official body such as TÜV as a safety attachment for the weight that it secures, must comply with EN 60598-2-17 Section 17.6.6 and must be capable of bearing a static suspended load that is ten times the weight of the fixture and all installed accessories.

Check that all external covers and rigging hardware are securely fastened.

Block access below the work area and work from a stable platform whenever installing, servicing or moving the fixture.

Do not operate the fixture with missing or damaged covers, shields or any optical component.

In the event of an operating problem, stop using the fixture immediately and disconnect it from power. Do not attempt to use a fixture that is obviously damaged.

Do not modify the fixture in any way not described in this manual or install other than genuine RUSH by Martin™ parts.

Refer any service operation not described in this manual to a qualified technician.

Introduction

The RUSH PAR 2 CT Zoom™ is a bright single-lens LED PAR Can. It offers white color temperature mixing using twelve 10 W CWUW (warm white and ultra white) LEDs and a 10° to 60° motorized zoom. This fixture also offers electronic dimming and strobe and features a bracket for floor or truss mounting.

The PAR 2 CT Zoom™ can be controlled using any DMX-compliant controller.

The fixture is supplied with a 1.5 m (5 ft.) power cable (local power plug not included) and a folding mounting bracket.

Before using the product for the first time

1. Read 'Safety information' on page 4 before installing, operating or servicing the fixture.
2. Unpack and ensure that there is no transportation damage before using the fixture. Never attempt to operate a damaged fixture.
3. If the fixture is not going to be hard-wired to an AC mains power source, install a local power plug (not supplied) on the end of the supplied power cable.
4. Before operating, ensure that the voltage and frequency of the local power source match the mains power requirements of the fixture.
5. Check the RUSH support pages on the Martin Professional website at www.martin.com for the most recent user documentation and technical information about the fixture. RUSH by Martin™ user manual revisions are identified by the revision letter at the bottom of the inside cover.

When the fixture is powered on for the first time, it may smoke slightly as it warms up, but this will only last a few minutes and is no cause for concern.

Physical installation



Read ‘Safety information’ on page 4 before installing the fixture.

The fixture is designed for indoor use only and must be used in a dry location with adequate ventilation. Ensure that none of the fixture’s ventilation slots are blocked.

Fasten the fixture to a secure structure or surface. Do not stand it on a surface or leave it where it can be moved or fall over. If you install the fixture in a location where it may cause injury or damage if it falls, secure it as directed in this user manual using a securely anchored safety cable that will hold the fixture if the primary fastening method fails.

Martin™ can supply safety cables and rigging clamps that are suitable for use with the fixture (see ‘Accessories’ on page 28).

Fastening the fixture to a flat surface

The fixture can be fastened to a hard, fixed, flat surface that is oriented at any angle. Ensure that the surface can support at least 10 times the weight of all fixtures and equipment to be installed on it.

Fasten the fixture securely. If you install the fixture in a location where it may cause injury or damage if it falls, install a safety cable as directed in ‘Securing with a safety cable’ on page 11.

Mounting the fixture on a truss

The fixture can be clamped to a truss or similar rigging structure in any orientation. When installing the fixture hanging vertically down, you can use an open-type clamp such as a G-clamp. When installing in any other orientation, you must use a half-coupler clamp (see illustration on right) that completely encircles the truss chord.



To clamp the fixture to a truss:

1. Check that the rigging structure can support at least 10 times the weight of all fixtures and equipment to be installed on it.
2. Block access under the work area.
3. Fold the legs of the mounting bracket together and bolt a rigging clamp securely to the mounting bracket. The bolt used must be M12, grade 8.8 steel minimum. It must pass through both mounting bracket legs and be fastened with a self-locking nut.

4. Working from a stable platform, hang the fixture with its clamp on the truss and fasten the clamp securely.
5. Secure the fixture with a safety cable as directed below.

Securing with a safety cable

Secure the fixture with a safety cable (or other secondary attachment) that is approved for the weight of the fixture so that the safety cable will hold the fixture if a primary attachment fails.

Loop the cable through one of the safety cable attachment points on the fixture (see arrows in illustration on right) and around a secure anchoring point.

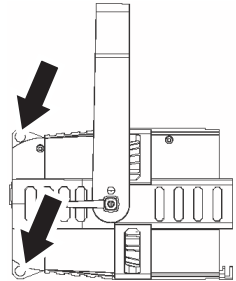

AC power



Read ‘Safety information’ on page 4 before connecting the fixture to AC mains power.

Warning! The mains power input cable supplied with the fixture is rated 6 A and can supply only one fixture with mains power. Do not connect any device to the fixture’s MAINS OUT power throughput socket when using this input cable. If you want to connect other fixtures to the MAINS OUT socket, see ‘Linking fixtures to power in a chain’ on page 12.

For protection from electric shock, the fixture must be grounded (earthed). The power distribution circuit must be equipped with a fuse or circuit breaker and ground-fault (earth-fault) protection.

Socket outlets or external power switches used to supply the fixture with power must be located near the fixture and easily accessible so that the fixture can easily be disconnected from power.

Do not insert or remove live Neutrik PowerCon connectors to apply or cut power, as this may cause arcing at the terminals that will damage the connectors.

Do not use an external dimming system to supply power to the fixture, as this may cause damage to the fixture that is not covered by the product warranty.

You can hard-wire the fixture to a building electrical installation if you want to install it permanently. Alternatively, you can install a power plug (not supplied) that is suitable for the local power outlets on the supplied power cable.

If you install a power plug on the power cable, install a grounding type (earthed) plug with integral cable grip that is rated minimum 250 V, 6 A. Follow the plug manufacturer's instructions and connect the wires in the power cable as shown in this table:

	Earth, Ground or 	Neutral or N	Live or L
US system	Green	White	Black
EU system	Yellow/green	Blue	Brown

The fixture has an auto-ranging power supply that accepts AC mains power at 100-240 V at 50/60 Hz. Do not apply AC mains power at any other voltage or frequency to the fixture.

Linking fixtures to power in a chain

If you obtain a 14 AWG / 1.5 mm² power input cable and 14 AWG / 1.5 mm² throughput cables from Martin™ (see 'Accessories' on page 28), you can relay mains power from one fixture to another by connecting fixtures to power in a linked daisy-chain, MAINS OUT throughput socket to MAINS IN input socket.

Using 14 AWG or 1.5 mm² cables from Martin™, you can link:

- Maximum eight (8) RUSH PAR 2 CT Zoom™ fixtures in total at 100-120 V, or
- Maximum eighteen (18) RUSH PAR 2 CT Zoom™ fixtures in total at 200-240 V.

Fixture overview

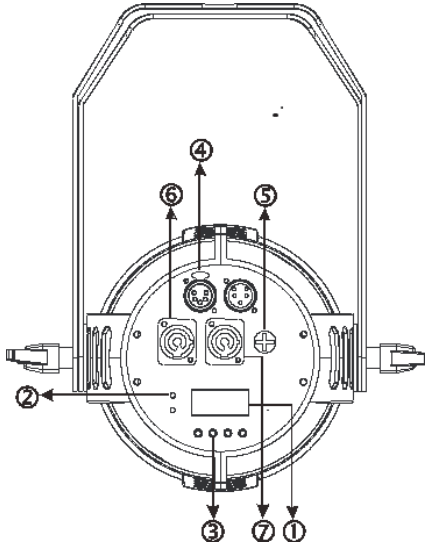

1 - Display

2 – Status LEDs

The two LEDs on the rear of the fixture have the following functions:

POWER	On	Power on
DMX	On	Valid DMX signal present

3 – Control buttons

MENU	<ul style="list-style-type: none"> • Activate the menus, or • Return to the previous level of the menu structure, or • Press and hold to exit the menus
DOWN	Scroll down through a menu
UP	Scroll up through a menu
ENTER	Confirm the selection

4 – 5-pin XLR DMX input/output sockets

5 – Primary (mains power) fuse F1

The T 6.3A fixture fuse is located in a fuseholder next to the power input/output connectors.

6 – AC mains power IN

A blue Neutrik PowerCon socket is provided to connect the fixture to AC mains power.

7 – AC mains power OUT (THRU)

See ‘Safety information’ on page 4. The light-grey Neutrik PowerCon socket can be used to supply power to other fixtures only if the supplied power input cable is replaced as directed in this manual and safety limits are respected.

Control data link

A DMX 512 data link is required in order to control the fixture via DMX. The fixture has 5-pin XLR connectors for DMX data input and output.

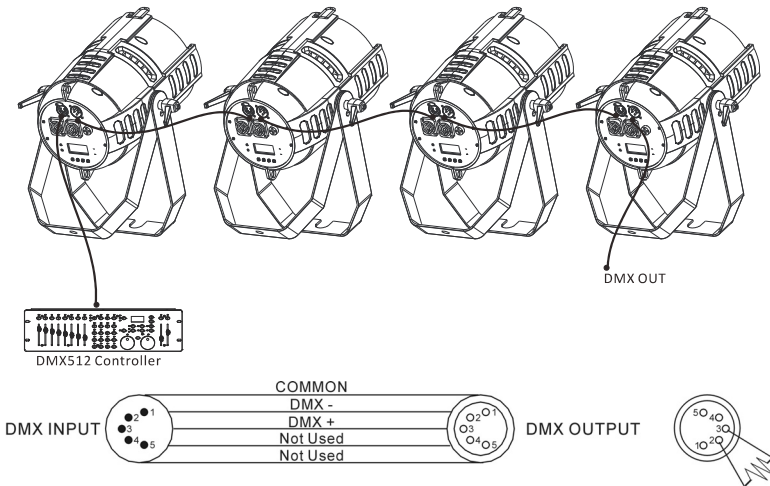

The number of fixtures that you can connect in a daisy chain is limited by the number of DMX channels required by the fixtures in relation to the maximum 512 channels available in one DMX universe. No matter how many channels are available, we recommend connecting a maximum of 32 fixtures in one daisy chain.

Note that if independent control of a fixture is required, it must have its own DMX channels. Fixtures that are required to behave identically can share the same DMX address and channels. To add more fixtures or groups of fixtures when the above limit is reached, add a DMX universe and another daisy-chained link.

Tips for reliable data transmission

Use shielded twisted-pair cable designed for RS-485 devices: standard microphone cable cannot transmit control data reliably over long runs. 24 AWG cable is suitable for runs up to 300 meters (1000 ft.). Heavier gauge cable and/or an amplifier is recommended for longer runs. The pinout on all connectors is pin 1 = shield, pin 2 = cold (-), and pin 3 = hot (+). Pins 4 and 5 in the 5-pin XLR connectors are not used in the fixture but are available for possible additional data signals as required by the DMX512-A standard. Standard pinout is pin 4 = data 2 cold (-) and pin 5 = data 2 hot (+).

To split the link into branches, use a splitter such as the Martin DMX 5.3 Splitter or RDM 5.5 Splitter.

Terminate the link by installing a DMX termination plug in the output socket of the last fixture. The termination plug, which is a male XLR plug with a 120 Ohm, 0.25 W resistor soldered between pins 2 and 3, “soaks up” the control signal so it does not reflect and cause interference. If a splitter is used, terminate each branch of the link.

Connecting the DMX data link

To connect the fixture to data:

1. Connect the DMX data output from the controller to the first fixture’s male XLR DMX input connector.
2. Connect the first fixture’s DMX output to the DMX input of the next fixture and continue connecting fixtures output to input. Terminate the last fixture on the link with a DMX termination plug.

Fixture setup

This section explains the fixture characteristics that can be set to determine how it can be controlled and will behave. These settings are made using the menus available in the control panel. Settings are retained in memory when the fixture is powered off.

A complete map of the control menu structure and brief explanations of their purposes can be found in ‘Control menus’ on page 24.

Using the control menus

- To access the control menus or to return to the previous level in the menu structure, press the MENU button.
- Navigate the menu structure using the DOWN, UP and ENTER buttons.
- If you have selected a menu option, confirm your selection and set that option using the ENTER button, or if you want to return to the previous

level in the menu structure without making a change, press the MENU button.

- To exit the menus, press and hold the MENU button.

DMX addressing

The DMX address, also known as the start channel, is the first channel used to receive instructions from a DMX controller. You control the fixture by sending signals from a DMX controller over this channel and the channels immediately above it – seven channels in total. If you give the first fixture DMX address 1, it will use channels 1 to 7. DMX address 8 is available for the next fixture, address 15 for the next fixture and so on.

If you want independent control, you must give each fixture its own DMX address. If you want grouped control and identical fixture behavior, give fixtures the same DMX address.

To set the fixture's DMX address:

1. In the fixture's control panel, use the UP and DOWN buttons to select DMX ADDRESS and press ENTER. The fixture's currently set DMX address will blink in the display.
2. Use the UP and DOWN buttons to select a new address.
3. Once the new address has been selected, press ENTER to confirm it (or press MENU to exit without making a change).

Dimming curves

Four dimming curves are available:

- MODE 1: LINEAR – The increase in light intensity appears to be linear as DMX value is increased.
- MODE 2: SQUARE LAW – light intensity control is finer at low levels and coarser at high levels.
- MODE 3: INVERSE SQUARE LAW – light intensity control is coarser at low levels and finer at high levels.
- MODE 4: S-CURVE – light intensity control is finer at low levels and high levels and coarser at medium levels.

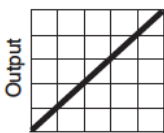

DMX %
Output
Optically linear

MODE 1

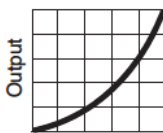

DMX %
Output
Square law

MODE 2

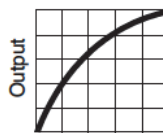

DMX %
Output
Inverse square law

MODE 3

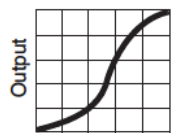

DMX %
Output
S-curve

MODE 4

To set the fixture's dimming curve:

1. Select DIMMER and press ENTER. The currently set mode will blink in the display.
2. Use the DOWN and UP buttons to select MODE 1, MODE 2, MODE 3, or MODE 4.
3. Once the mode has been selected, press ENTER to set it (or press MENU to exit without making a change).

Blackout or Hold if DMX signal stops

You can decide how the fixture should behave if you are controlling the fixture via DMX and you stop sending the DMX signal.

1. Select BLACKOUT and press ENTER. The currently set blackout mode will blink in the display.
2. Using the DOWN and UP buttons, select YES or HOLD to decide how the fixture should respond if it stops receiving a DMX signal:
 - If you select YES, the fixture will black out
 - If you select HOLD, the fixture will continue to show the effect that it is displaying at the time.
3. Press ENTER to confirm your choice (or press MENU to exit without making a change).

Display panel backlight sleep mode

To set the display panel backlight to remain on all the time or to automatically sleep when the control panel is not in use:

1. Select BACKLIGHT and press ENTER.
2. Use the DOWN and UP buttons to select ON (display backlight constantly on) or OFF (display backlight sleeps after a short period with no activity). Press ENTER to confirm (or press MENU to exit without making a change).

Dimmer speed

Dimmer speed provides two options:

- SNAP sets the dimmer to exactly follow changes in dimming level sent from the controller. This gives the fastest dimmer response.
- FADE adds a one-second (approx.) smooth fade to all changes in dimming level sent from the controller. This gives the smoothest dimmer response.

To set the dimmer speed:

1. Select DIMMER SPEED and press ENTER to confirm.

2. Use the DOWN and UP buttons to select FADE or SNAP. Press Enter to confirm (or press MENU to exit without making a change).

Fixture test

Automatic tests of all effects or manual test of individual effects can be run from the control menus.

Automatic effects test

To perform a complete test of all of the fixture's effects:

1. Select FIXTURE TEST and press ENTER to confirm. The automatic test will run.
2. To stop the test and exit, press MENU.

Manual effects test and single standalone scene

The Manual effects test menu can be used to test the fixture's effects individually and to set a single standalone scene that the fixture will show each time it is powered on.

1. Select MANUAL TEST and press ENTER.
2. Use the DOWN and UP buttons to select an effect (White 1, White 2, Shutter, Dimmer or Zoom). Press ENTER to confirm your selection.
3. Use the DOWN and UP buttons to change the value (000-255). This will be the equivalent of sending this DMX value to the selected effect.
4. Press ENTER to confirm your selection and activate the effect (or press MENU to exit).
5. If you have confirmed a selection with the ENTER button, press MENU to return to the list of effects.
6. If you want, you can now scroll to another effect and set a value for it as described above. This effect will be added to the effects that you have already set.

See also 'Single standalone scene' below.

Cooling fan options

You can set cooling fans to run at constant low speed or automatically regulated speed depending on whether light output intensity or quiet operation is your highest priority.

1. Select FAN MODE and press ENTER. The currently set fan mode will blink in the display.
2. Using the DOWN and UP buttons, toggle between the two modes:
 - If you select LOW, fans are set to constant low speed. This gives quieter operation but light output is reduced when necessary to control fixture temperature.

- If you select AUTO, fan noise levels vary as fans control fixture temperature, but light output is constant.
3. Press ENTER to confirm your choice (or press MENU to exit without making a change).

Single standalone scene

If you power the fixture off while it is running the effect – or the combination of effects – that you have set in the MANUAL TEST menu (see above), it will hold that setting in memory. The next time you power the fixture on, it will display those effects. This feature lets you set a standalone scene that runs automatically each time the fixture is powered on.

Note that when the fixture is running a single standalone scene, it will not respond to DMX control signals. To restore DMX operation, exit the MANUAL TEST menu on the control panel.

Fixture information

Fixture temperature readout

To check the onboard temperature of the fixture:

1. Select TEMP and press ENTER. The display will show the temperature of the unit.
2. Press MENU to exit.

Fixture operating time

The fixture operating time counter monitors the total number of hours the fixture has been in operation since manufacture. To display the counter:

1. Select FIXTURE TIME and press ENTER. The display will show the time the unit has been running.
2. Press MENU to exit.

Firmware version

To see which software version is installed in the fixture:

1. Select FIRMWARE VERSION and press ENTER. The firmware version will be shown.
2. Press MENU to exit.

Reset

The fixture resets each time it is powered off and on, but it is possible to force a reset at any time:

1. Select RESET and press ENTER to confirm.
2. Give the fixture time to reset.

Effects

The effects below can be controlled using DMX. See 'DMX protocol' on page 23 for full details of DMX channels and values.

Color temperature control

White color temperature can be controlled by mixing warm white and cold white LEDs.

Electronic dimming

Overall intensity can be adjusted 0-100% using electronic dimming.

Shutter effect

The electronic 'shutter' effect provides instant open and blackout as well as variable speed regular and random strobe and pulse effects.

Zoom

Zoom angle can be varied from 10° to 60°.

Maintenance



Read ‘Safety information’ on page 4 before servicing the fixture.

Refer any service operation not described in this user manual to a qualified service technician.

Disconnect the fixture from mains power and allow to cool completely before cleaning or servicing.

Service fixtures in an area where there is no risk of injury from falling parts, tools or other materials.

Excessive dust, smoke fluid, and particle buildup degrades performance, causes overheating and will damage the fixture. Damage caused by inadequate cleaning or maintenance is not covered by the product warranty.

Cleaning

The cleaning of external optical lenses must be carried out periodically to optimize light output. Cleaning schedules for lighting fixtures vary greatly depending on the operating environment. It is therefore impossible to specify precise cleaning intervals for the fixture. Environmental factors that may result in a need for frequent cleaning include:

- Use of smoke or fog machines.
- High airflow rates (near air conditioning vents, for example).
- Presence of cigarette smoke.
- Airborne dust (from stage effects, building structures and fittings or the natural environment at outdoor events, for example).

If one or more of these factors is present, inspect fixtures within their first 100 hours of operation to see whether cleaning is necessary. Check again at frequent intervals. This procedure will allow you to assess cleaning requirements in your particular situation. If in doubt, consult your RUSH by Martin dealer about a suitable maintenance schedule.

Use gentle pressure only when cleaning, and work in a clean, well-lit area. Do not use any product that contains solvents or abrasives, as these can cause surface damage.

To clean the fixture:

1. Disconnect the fixture from power and allow it to cool for at least 15 minutes.
2. Vacuum or gently blow away dust and loose particles from the outside of the fixture and the air vents with low-pressure compressed air.

3. Clean lenses by wiping gently with a soft, clean lint-free cloth moistened with a weak detergent solution. Do not rub the surface hard: lift particles off with a soft repeated press. Dry with a soft, clean, lint-free cloth or low-pressure compressed air. Remove stuck particles with an unscented tissue or cotton swab moistened with glass cleaner or distilled water.
4. Check that the fixture is dry before reapplying power.

Fuse replacement

If the fixture is completely dead, the fixture's primary fuse F1 may have blown and it may be necessary to install a new fuse. This fuse is located in a fuseholder next to the Mains OUT socket on the connections panel (see **5** in 'Fixture overview' on page 13).

To change the fuse:

1. Disconnect the fixture from power and allow it to cool for at least 15 minutes.
2. Use a large flat-bladed screwdriver to unscrew the cap of the fuseholder.
3. Replace the fuse with one of the same type and rating only.
4. Reinstall the fuseholder cap before reapplying power.

Service and repairs

There are no user-serviceable parts inside the fixture. Do not open the housing.

Refer any service or repair operation not described in this manual to an authorized RUSH by Martin™ service technician. Do not try to carry out such an operation yourself, as doing so may present a health or safety risk. It may also cause damage or malfunction, and it may void your product warranty.

Installation, on-site service and maintenance can be provided worldwide by the Martin Professional Global Service organization and its approved agents, giving owners access to Martin's expertise and product knowledge in a partnership that will ensure the highest level of performance throughout the product's lifetime. Please contact your RUSH by Martin supplier for details.

DMX protocol

Channel	Value	Function	Fade type	De- fault
1	0-255	Dimmer 0 → 100%	Fade	0
2	0-255	Dimmer Fine 0 → 100%	Fade	0
3		Strobe and pulse effects	Snap	12
	0-7	Off		
	8-15	Open		
	16-131	Strobe slow → fast		
	132-139	Open		
	140-181	Pulse fast close, slow open		
	182-189	Open		
	190-231	Pulse fast open, slow close		
	232-239	Open		
	240-247	Strobe random		
248-255	Open			
4	0-255	Warm White 0 → 100%	Fade	255
5	0-255	Cold White 0 → 100%	Fade	255
6	0-26	Color Temperature disabled	Fade	0
	27-72	Color Temperature from 2700 to 7800 K in approx. 100 K steps (Cold and Warm LED channels are disabled)		
	73-255	7800 K		
7	0-255	Zoom wide → narrow	Fade	128

Control menus

To access the control menus, press the MENU button. Use the UP and DOWN buttons to navigate the menus. Select any required menu option using the ENTER button. For more information, see ‘Using the control menus’ on page 15.

Default fixture settings are shown in **bold**.

Menu	Setting/value	Explanation
DMX Address	001 –512	Set fixture’s DMX address
Dimmer	Mode 1	Optically linear
	Mode 2	Square law
	Mode 3	Inverse square law
	Mode 4	S-curve
DMX State	Blackout	Set fixture behavior if DMX signal stops: blackout or hold current effect
	Hold	
Backlight	Off	Automatically turn off display backlight when not in use
	On	
Dimmer Speed	Fade	Optimize dimmer for smoothness
	Snap	Optimize dimmer for speed
Manual Test	Warm	Manually test individual effects Set single standalone scene
	Cold	
	Zoom	
	Dimmer	
	Strobe	
Auto Test		Automatic test of all effects
Temp.		Display fixture’s current temperature
Fan Mode	Low	Adjust cooling fan speed
	Auto	
Fixture time		Display total operation time
Firmware Version		Display currently installed firmware version
Reset		Force a fixture reset

Troubleshooting

This section describes a few common problems that may occur during operation and provides some suggestions for easy troubleshooting:

Symptom	Potential cause	Remedies
No light from fixture or fans not working.	Power supply issue, such as blown fuse, faulty connector or damaged cable.	Check whether fixture's power indicator LED is lit. Check all power connections and cables. Replace fixture's primary fuse.
One of the control channels is unresponsive or only responds intermittently.	DMX setup or DMX link fault. Damaged step motor or cable connection.	See next section. Contact your RUSH by Martin™ authorized distributor or service center for assistance.
Fixture does not respond to DMX control.	Incorrect DMX addressing. Fault on DMX link due to damaged connector or cable, or potential interference from proximity to a high-voltage installation.	Ensure that fixture's DMX address matches address set on DMX control device. Check that fixture DMX LED is on, and if not, check all DMX cables and connections. Ensure that DMX link is terminated. Check that all components on DMX link use standard DMX polarity. Attempt to control the fixture with another DMX control device. Move or shield link if it is close to an unshielded high-voltage installation.

Specifications

Physical

Dimensions (LxWxH)..... 266x287x329 mm (10.5x11.3x13.0 in.)
 Weight..... 5.5 kg (12.1 lbs.)

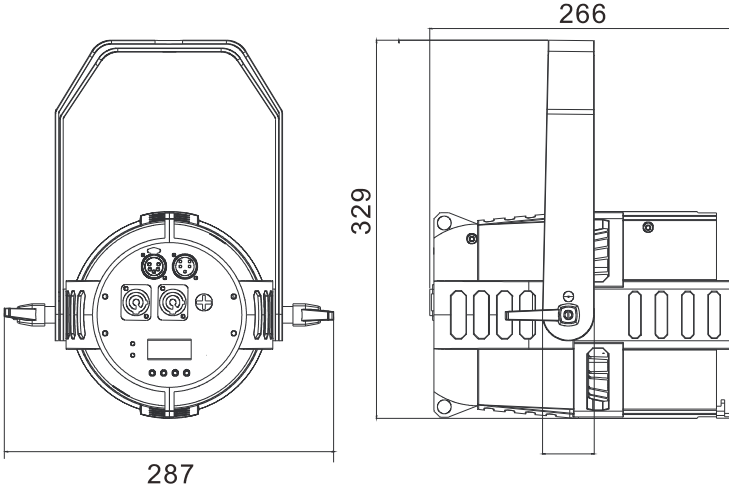

Dynamic Effects

Color temperature control..... Variable 2700 - 7800 K
 Color mixing..... WW-CW (warm white & cold white)
 Electronic dimming 0 - 100%, four dimming curve options
 Strobe and pulse effects..... Variable speed and action, random strobe
 Electronic 'shutter' effect..... Instant open and blackout
 Zoom..... Motorized

Control and Programming

Control options DMX, single standalone scene
 DMX channels 7
 DMX address setting Control panel with LCD display
 Standalone programming Control panel with LCD display
 Protocol..... USITT DMX512/1990

Optics

Light source 12 x 10 W CWUW LEDs
 Minimum LED lifetime..... 50 000 hours (to >70% luminous output)*
 CRI (Color rendering index)..... 90
 Beam angle 10° - 60°

**Figure obtained under manufacturer's test conditions*

Construction

Color Black
Housing Aluminum
Protection rating IP 20

Installation

Mounting points Adjustable bracket, surface or truss mount
Location Dry location
Orientation Any
Minimum distance to illuminated surfaces 0.2 m (8 in.)
Minimum distance to combustible material 0.1 m (4 in.)

Connections

AC power input Neutrik PowerCon
AC power throughput Neutrik PowerCon
DMX data in/out 5-pin locking XLR

Electrical

AC power 100-240 V nominal, 50/60 Hz
Typical power consumption 152 W
Fuse T 6.3 A
Power supply unit Auto-ranging electronic switch mode

Maximum power and current

120 V, 60 Hz 1.25 A, 151 W, PF 0.993
230 V, 50 Hz 0.66 A, 148 W, PF 0.961
*Measurements made at nominal voltage with all LEDs at full intensity.
Allow for a deviation of +/- 10%.*

Thermal

Cooling Forced air (temperature regulated, low noise)
Maximum ambient temperature (Ta max.) 40° C (104° F)
Minimum ambient temperature (Ta min) 0° C (32° F)
Total heat dissipation* 520 BTU/hr.
**Calculated, +/- 10%, at full intensity.*

Approvals



EU safety EN 60598-2-17 (EN 60598-1), EN 62471, EN 62493
EU EMC EN 55015, EN 55032, EN 55103-2,
..... EN 61000-3-2, EN 61000-3-3, EN 61547
US safety UL 1573
US EMC FCC Part 15 Class A

Canadian safety.....	CSA C22.2 No. 166
Canadian EMC	ICES-003 Class A
Australia/NZ.....	C-TICK N4241

Included Items

- Power cable, 6 A, 18 AWG, 0.75 mm², UL- listed, H05VV-F, 1.5 m, without mains plug
- Mounting bracket
- Gel holder

Accessories

- Additional Gel Holders for RUSH PAR 2™, set of 10P/N 46000106

Cables, 16 A, for connection to power in chains

- Power input cable, 14 AWG, SJT, 1.5 mm², H05VV-F, with PowerCon input connector, 3 m (9.8 ft.).....P/N 11541508
- Power relay cable, 14 AWG, SJT, 1.5 mm², H05VV-F, with PowerCon connectors, 1.4 m (4.6 ft.).....P/N 11541509
- Power relay cable, 14 AWG, SJT, 1.5 mm², H05VV-F, with PowerCon connectors, 2.25 m (7.4 ft.).....P/N 11541510
- Power relay cable, 14 AWG, SJT, 1.5 mm², H05VV-F, with PowerCon connectors, 3.25 m (10.7 ft.).....P/N 11541511

Power connectors

- Neutrik PowerCon NAC3FCA
power input connector, cable mount, blueP/N 05342804
- Neutrik PowerCon NAC3FCB
power output connector, cable mount, light grey.....P/N 05342805

Installation hardware

- Half-coupler clamp.....P/N 91602005
- G-clamp (suspension vertically downwards only)P/N 91602003
- Quick-trigger clamp (suspension vertically downwards only)..P/N 91602007
- Safety cable, safe working load 50 kg.....P/N 91604003

Related Items

- RUSH Software Uploader 1™P/N 91611399

Ordering Information

- RUSH PAR 2 CT Zoom™ in cardboard box, EU modelP/N 90280060
- RUSH PAR 2 CT Zoom™ in cardboard box, US modelP/N 90280065

Specifications are subject to change without notice. For the latest product specifications, see www.martin.com



Disposing of this product

RUSH by Martin™ products are supplied in compliance with Directive 2012/19/EC of the European Parliament and of the Council of the European Union on WEEE (Waste Electrical and Electronic Equipment), where applicable. Help preserve the environment! Ensure that this product is recycled at the end of its life. Your supplier can give details of local arrangements for the disposal of RUSH by Martin products

Photobiological Safety Warning

The label shown below is displayed on this product. If it becomes difficult or impossible to read, it must be replaced using the illustration below to reproduce a new label sized 45 x 18 mm, in black on a yellow background.

RISK GROUP 2

CAUTION. Possibly hazardous optical radiation emitted from this product.

Do not stare at operating lamp. May be harmful to the eyes.

RUSH™
by Martin®