

VIO Series

INDEX

Introducing The Series	4
VIO L210	6
Unique Acoustic Design	8
Advanced DSP	10
Flying Hardware	12
VIO S318	14
Tri-Amped Active Subwoofer	16
Outstanding Performance	18
Software	20
System Configurations	22
Small System	24
Medium System	26
Large System	28
Stacked System	30
Tech Specs	32
Accessories	34

INTRODUCING VIO SERIES

In the last 10 years, since DVA series' launch on the pro audio market, dBTechnologies has set new standards in the sound reinforcement industry, bringing the benefits of line array technology to a much wider range of users.

With the new VIO series dBTechnologies is ready to step up to the next level, presenting a fully powered line array and sub series intended for large sound reinforcement applications.

Making the most of many years experience developing powered speaker systems, alongside with innovative solutions in acoustic design and digital sound processing, dBTechnologies created a line array solution able to face smoothly professional production requirements.

Freshly designed wooden cabinets, premium components, last generation amplifying technology, as well as an advanced DSP programming, come together to deliver imposing sound pressure levels combined with an outstanding control of dispersion and a detailed, clear cut audio performance. In addition to that, all the VIO systems can be remotely controlled via RDNet protocol and, last but not least, the line array modules features an integrated rigging system and dedicated accessories in order to ensure simple and quick configuration and set up operations.

**SMARTER
LIGHTER
FASTER
STRONGER**





VIO L210

As a result of many years' experience developing solutions for powered line array systems, VIO L210 reaches the next level among dBTechnologies' speaker range aimed at larger sound reinforcement applications. The internal acoustic design and sound processing developed by dBTechnologies' R&D department merge to deliver outstanding performances in terms of sound pressure, coverage coherence, intelligibility and sound definition.

A detailed technical line drawing of a speaker enclosure, showing the internal structure, including the driver array, waveguide, and various mounting points. The drawing is oriented vertically and serves as a background for the text.

2-WAY ACTIVE LINE ARRAY SYSTEM

**NETWORK READY WITH AN INTEGRATED
RDNET PORT**

**NEWLY DESIGNED WOODEN ENCLOSURE COATED
WITH POLYUREA**

**SMOOTH CONFIGURATION AND SET UP
OPERATIONS THANKS TO THE INTEGRATED
3-POINT RIGGING HARDWARE**

**EXCLUSIVELY DESIGNED HF WAVEGUIDE FOR
IMPRESSIVE THROW DISTANCE AND PHASE
COHERENCE**

**ALUMINIUM PHASE PLUGS FOR AN EXTREMELY
CONSTANT DISPERSION**

**ADVANCED DSP FEATURING LINEAR PHASE FIR
FILTERS FOR IMPROVED INTELLIGIBILITY**

UP TO 6 MODULES IN A SINGLE 16A 230V CIRCUIT

**LIGHTWEIGHT NEODYMIUM MAGNETS FOR ALL
TRANSDUCERS**

**ON-BOARD DOUBLE ROTARY EQ CONTROL SYSTEM
FOR PRECISE TUNING**

UNIQUE ACOUSTIC DESIGN

Functional yet unobtrusive design

Made of solid multiplex plywood coated with a black polyurea finish, the housing is fronted with a black grille which complete a sober, unobtrusive look which can easily adapt to any scenic design. The speaker's cabinet is easy to tote thanks to its 4 handles, 1 per side and 2 on the back, and its amplifier module is protected with an integrated black raincover.

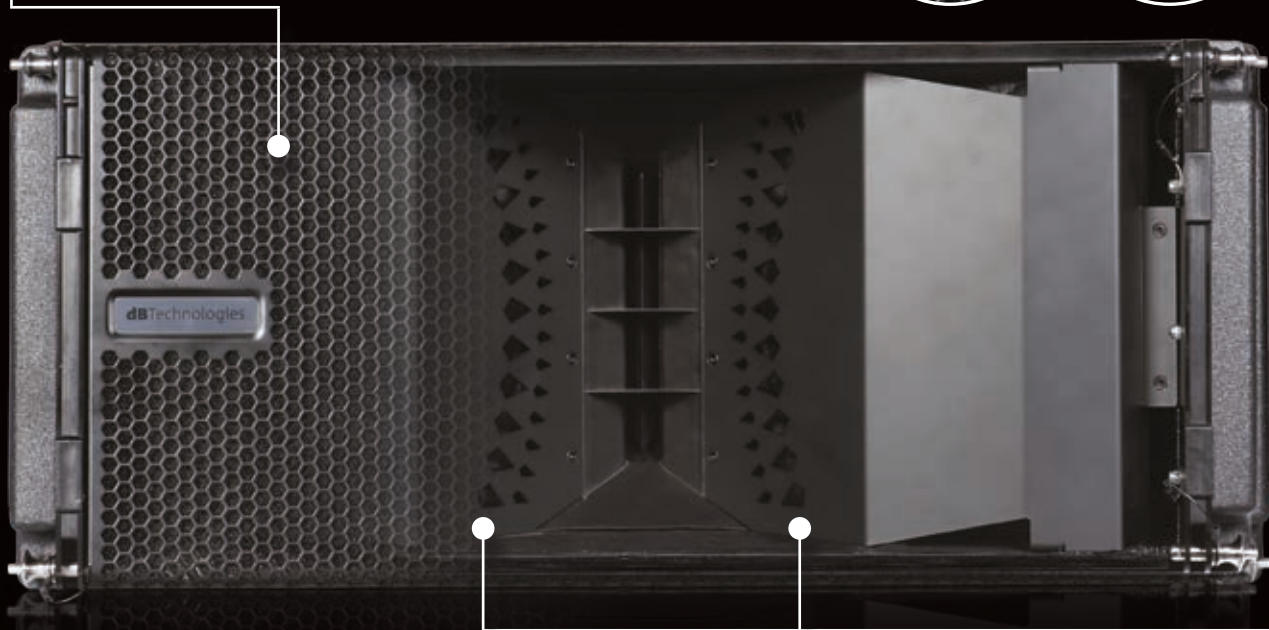

Phase plug

Acoustic enclosure is completed by two massive aluminum phase plugs located in front of both 10" woofers. Their external surface is the prosecution of the constant directivity high-frequency waveguide.

Each phase plug features 26 diamond-shaped holes essential to reduce the interference between the two LF emission points and to improve frequency and transient response.



Woofers

The two premium 10" neodymium transducers, positioned in a V form and sealed in a bass reflex enclosure, have been custom-designed to improve efficiency. In fact, their voice coils, made of copper plus aluminum coating, are designed to last even in the most demanding conditions, providing an accurate transient response and an extended low-end reproduction. Furthermore, these transducers have been specifically designed for the VIO in order to make the most of the system.

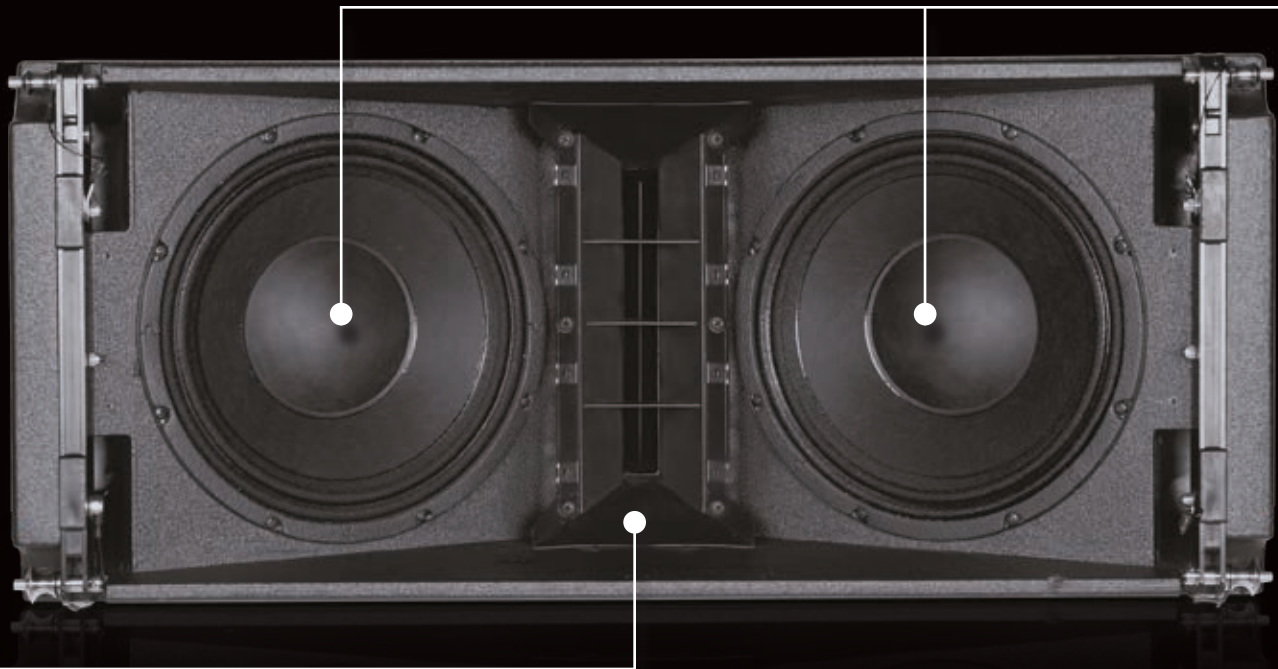
**High-frequency**

One single 3" voice coil compression driver (1.4" exit throat) accurately delivers high frequencies. A brand new waveguide contributes to create a cylindrical wavefront, allowing a very precise high-frequency directivity control, much to the advantage of the system's throw-distance.

The crossover frequency between the 2 ways lows down to 950 Hz and each module guarantees a uniform 100° horizontal coverage.



ADVANCED DSP

Advanced DSP paired with notable efficiency

The module features a 900W RMS Class D Digipro G3 highly efficient amplifier allowing the system to achieve up to 135 dB SPL. High efficiency is a key feature of the VIO L210: it is actually possible to connect up to 6 modules on a single 16A 230V circuit.

The amplifier also features an auto-range circuit and is fed via PowerCON TRUE1 waterproof connectors.

A perfectly coherent coverage is granted even at a long distance thanks to advanced sound processing with FIR filters. The pre-amp module is also equipped with a digital optical isolation on the signal input stage, which makes the system more resistant to any interference.



On board EQ controls

VIO L210 features a double rotary user interface to process the system manually. The first rotary is dedicated to low frequency adjustments in order to control coupling effects depending on the array dimensions. The second rotary helps to compensate for the high frequencies loss due to throw distance.

Both rotaries features several accurate presets, while the prediction software dBTechnologies Composer provides for more precise configurations. Any preset can be easily changed remotely via dBTechnologies Network.



Rotary 1 - Speaker coupling presets

Depending on the dimension of the array, the coupling effect affects frequency response. This dedicated “speaker coupling” control allows the user to attenuate the mid-low frequency according to the total number of line array cabinets.

SPEAKER COUPLING		
NUMBER OF CABINETS	2 → 6	A
	7 → 8	B
	9 → 10	C
	11 → 12	D
	13 → 14	E
	more than 15	F
	Bass boost	G
	service	

Rotary 2 - High Freq. compensation presets

Being a considerable long-throw system, VIO L210 is capable to provide incredibly flat response all over the target area also thanks to the high frequencies compensation control. Choosing among the different presets, allows the user to compensate high frequencies loss due to air absorption in each cabinet.

HIGH FREQ. COMPENSATION		
THROW DISTANCE m [ft]	FLAT	1
	front fill 0 → 5 [16]	2
	6 [17] → 20 [66]	3
	21 [67] → 30 [98]	4
	31 [99] → 40 [131]	5
	41 [132] → 50 [164]	6
	51 [165] → 60 [197]	7
	more than 61 [198]	8

FLYING HARDWARE

Smart rigging hardware & accessories

The VIO L210 comes with a built-in 3-point rigging system allowing a smooth and fast set up of the system. The 2 front links easily connect the modules from any angle.

The back central rigging strand is equipped with a hook type link to set the relative splay angles, determined via the prediction software dBTechnologies Composer.

While lifting up the array, the rigging strand will automatically block the system at the preset angles. Splay angles can be set directly while the system is still located on the transport cart DT-VIOL210, which houses up to 4 modules.



Flying and stacking cabinets

The dedicated flying frame DRK 210 comes with 2 hooks whose design allows to set a more precise inclination of the array. The DRK 210 can also serve as a groundstacking accessory to secure VIO L210 cabinets on a VIO S318 subwoofer. When not in use, the flying frame can be fixed and stored on the top lid of DT-VIOL210 transport cart. Even details like cables mounts, or the attachment of a laser inclinometer are included in the design.





VIO S318

As for lower frequencies, the VIO series is completed by VIO S318 subwoofer, a one of a kind system both for its acoustic configuration and majestic output. Indeed, dBTechnologies succeeded in designing an extraordinary powerful triple 18" woofer system while maximizing in-phase frontal emission and extending lower frequencies down to 35 Hz.





**ACTIVE TRI-AMPED 3x 18" BASSREFLEX
SEMI-HORN LOADED SUBWOOFER**

**INTERNAL DESIGN TO MAXIMIZE IN-PHASE
FRONTAL EMISSION**

**ON-BOARD DELAY FOR PERFECT TIME
ALIGNMENT**

**ON-BOARD CARDIOID ARRAY CONFIGURATION
PRESET**

FREQUENCY RANGE EXTENDING DOWN TO 35HZ

**NETWORK READY WITH AN INTEGRATED
RDNET PORT**

**POLYUREA PAINTING ON A ROAD-RESISTANT
WOODEN ENCLOSURE**

TRI-AMPED ACTIVE SUBWOOFER

VIO S318 is equipped with 3x18" woofers, 2 of which are half horn loaded, while the third one is a direct radiation woofer. This way, the sub combines the contribution of two different configurations.

The 3 woofers are aligned in order to achieve a perfect phase response. Its innovative acoustic design contributes in creating an unprecedented performance/ dimension ratio for a triple woofer powered system.

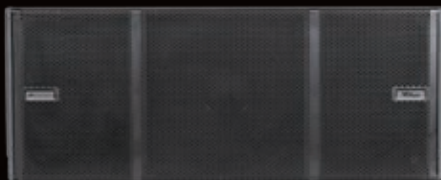

Designed to pair perfectly with VIO L210, VIO S318 features 3x18" woofers and Digipro G3 amplification technology encompassed in a sturdy plywood cabinet designed to ease transport, storage, as well as multi-sub configurations.



The high quality multiplex housing is reinforced with a robust polyurea finish and equipped with 4 aluminium handles per side. The eyelets on the top of the cabinet allow to fix the DRK-210 flybar, while 4 additional eyelets allow to fasten the load during transport using ratchet straps.



The internal configuration of the 3 woofers maximizes the acoustic radiant surface, delivering a solid sound performance.



OUTSTANDING PERFORMANCE



The 3 DIGIPRO G3 amplifiers deliver a total 2700 W RMS power, allowing the system to reach up to 143dB SPL. A solution combining resolute power, compact design and ease of use.

The system features an integrated delay module achieving up to 9.9 ms delay with 0.1 ms steps (a further delay can be set via RNet remote control software). The crossover module sets both the low pass filter and the highpass filter for the integrated crossover output. The system also features an attenuation control, a polarity switch and an RNet port for remote control.

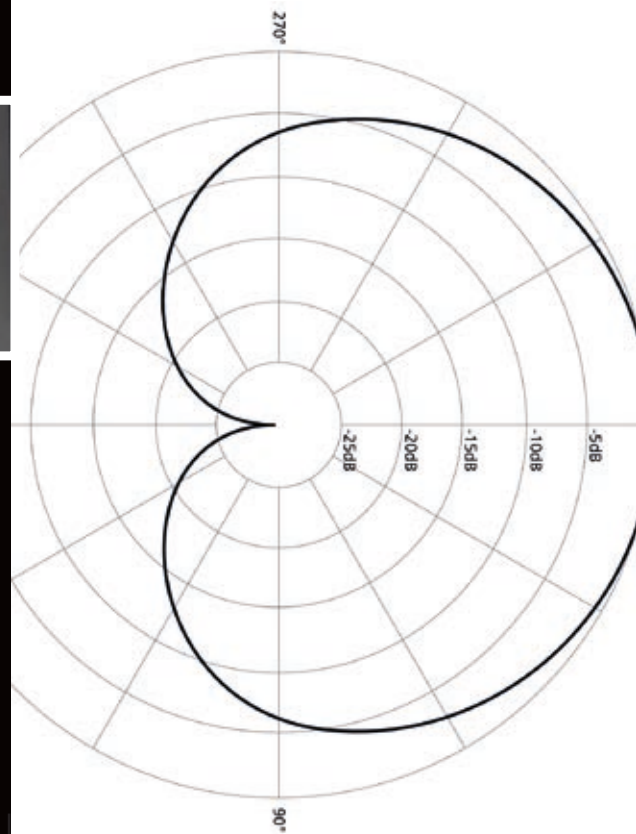
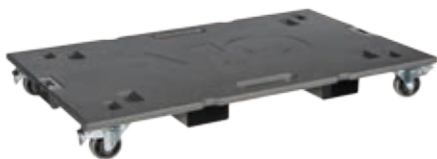

DO-VIOS318

The dolly transport DO-VIOS318 allows to transport up to 3 subs simultaneously, both on wheels or on the forklift truck. As an alternative to the dolly, 4 wheels can be mounted on the rear side of the cabinet.

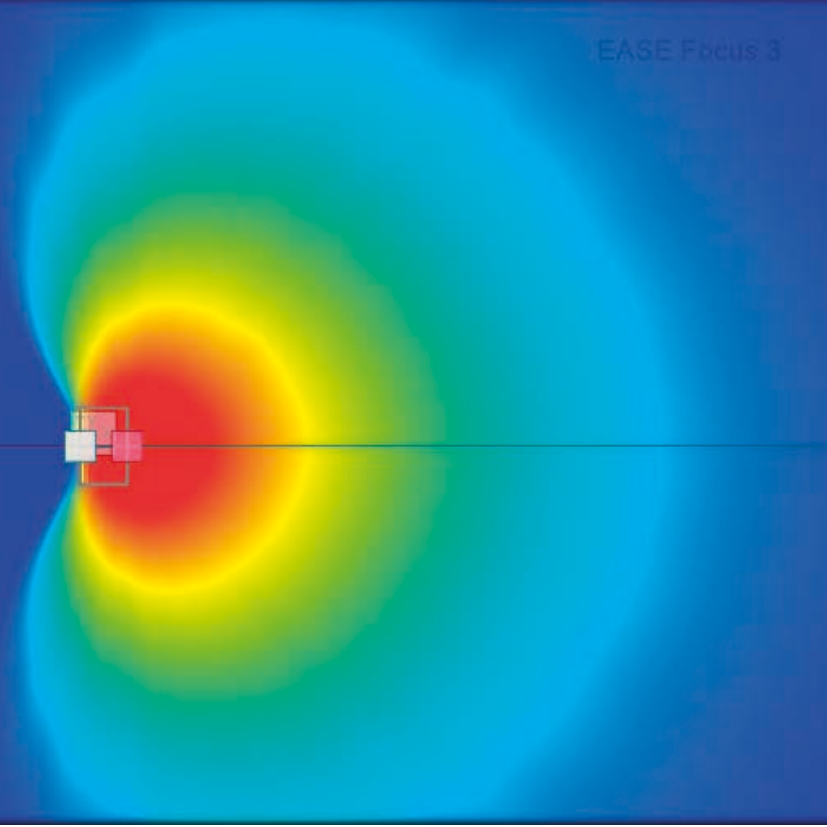

In cardioid configurations with 3 subs, the 'cardioid' button allows to process automatically the sub facing backwards, in order to achieve the maximum cancellation. The recessions on the top of the sub facilitates the passage of the cables between the cabinets.

VIO series' simulation models for Ease Focus 3 are available at dbtechnologies.com, as well as the proprietary prediction software dBTechnologies Composer.

SOFTWARE



dBTechnologies

NETWORK

Fully compatible with Network

VIO Series is fully compatible with dBTechnologies Network. This software allows the user to remotely control dBTechnologies products using an RNet Protocol, obtaining advanced management and monitoring powers of the sound reinforcement system in real time. Features:

- Monitor levels, limiters, and temperatures
- Select system presets
- Manage EQ, Delay and Gain of modules
- Configure setups off-line
- Mute and solo units
- Group modules
- Test each way of the amplifier
- Tap into LAN and USB interfaces
- Multi-threading management
- Camera preset feature (manages switch between multiple layout snapshots in the workspace)





dBTechnologies
COMPOSER

dBTechnologies Composer-ready

dBTechnologies Composer is a line array configuration software which has been especially developed to optimize VIO and DVA systems alignment and acoustic performance.

It is possible to simulate system reinforcement physics in order to set up a system in a fast and easy way according to your needs and the safety precautions.

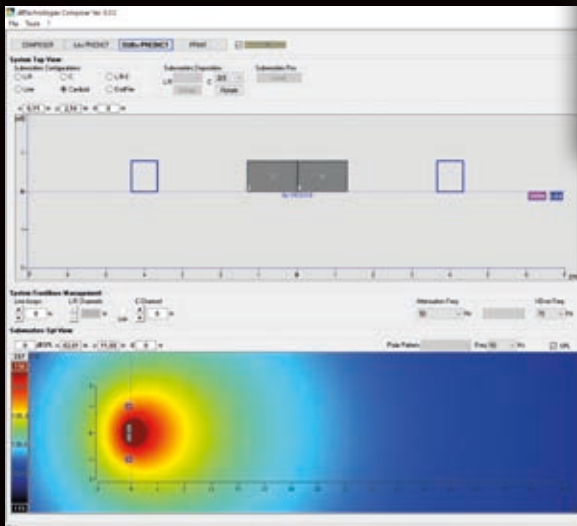
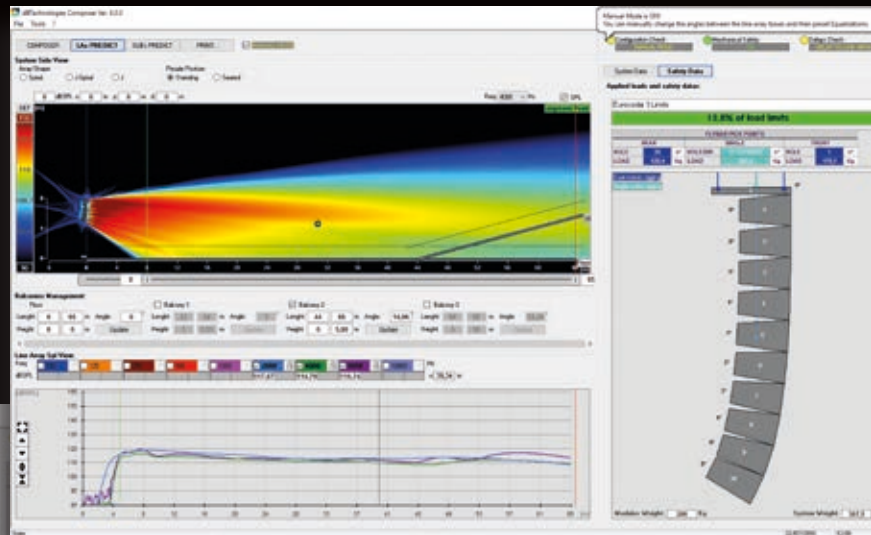

Furthermore the software allows the user to predict acoustic coverage of both tops and subs, splay angles and it automatically checks the set up presets in order to evaluate the efficiency of the system and its nominal coverage.

SYSTEM CONFIGURATIONS

Aimed at larger sound reinforcement applications, the new VIO Line Array and Sub series also features a remarkable versatility, allowing several configurations optimized for different sized venues and audience.

An advanced Digital Sound Processing, an innovative rigging system, smart accessories and a simple and effective monitoring system allow users to get the most out of VIO system both in larger suspended applications and in smaller stacked configurations.





SMALL SYSTEM

12 x VIO L210
4 x VIO S318

DESCRIPTION

6 VIO L210 with DRK-210 suspending bar per side
Application height: 6/8 meters
Single cluster weight: 193 kg / 425 lbs (bumper included)

POWER SPECIFICATIONS - IEC60268-5

VOLTAGE	NOMINAL POWER 1/8	MAX POWER USAGE 1/3	IDLE POWER (NO SIGNAL)
230V	29 A - 3520 W	63 A - 8456 W	5 A - 478 W
115V	50 A - 3524 W	111 A - 8624 W	8 A - 462 W

SETTINGS

DSP presets, relative splay angles and subwoofer configurations are shown in dBTechnologies Composer prediction software.
CROSSOVER POINT suggested: 85/90 hz.

REQUIRED EQUIPMENT

QUANTITY	MODEL	DESCRIPTION
12	VIO L210	Active two-way line array module
4	VIO S318	Active high power triple 18" subwoofer
2	DRK-210	Flybar for VIO L210
10	DPTC-70L	PowerCON TRUE1 - PowerCON TRUE1 power link cable for L210 (70 cm)
2	DPTC-160L	PowerCON TRUE1 - PowerCON TRUE1 power link cable for S318 (160 cm)
12	DAC-70	XLR link cable for L210 (70 cm)
4	XLR STANDARD CABLES	Audio connection cable between subwoofer clusters
1	CAT-5 STANDARD CABLES	Cat-5 cables connection long enough for sub-config needed
10	RJ45-RJ45-75	RDNet cat-5 cables link between L210 (75 cm)
2	RJ45-RJ45-150	RDNet cat-5 cables link between S318 (150 cm)
3	RDC-45 M	RJ-45 to XLR male conversion cable, RDNet
1	RDNET CONTROL-8	8 output RDNet master unit
4	DPTC-1000M	Master power cable to PowerCON TRUE1 (10 meters)

RECOMMENDED EQUIPMENT

QUANTITY	MODEL	DESCRIPTION
3	DT-VIOL210	Touring cart for 4x VIO L210
2	DO-VIOS318	Dolly transport for VIO S318

**SUGGESTED WIRING PLAN
FOR AVERAGE USE**

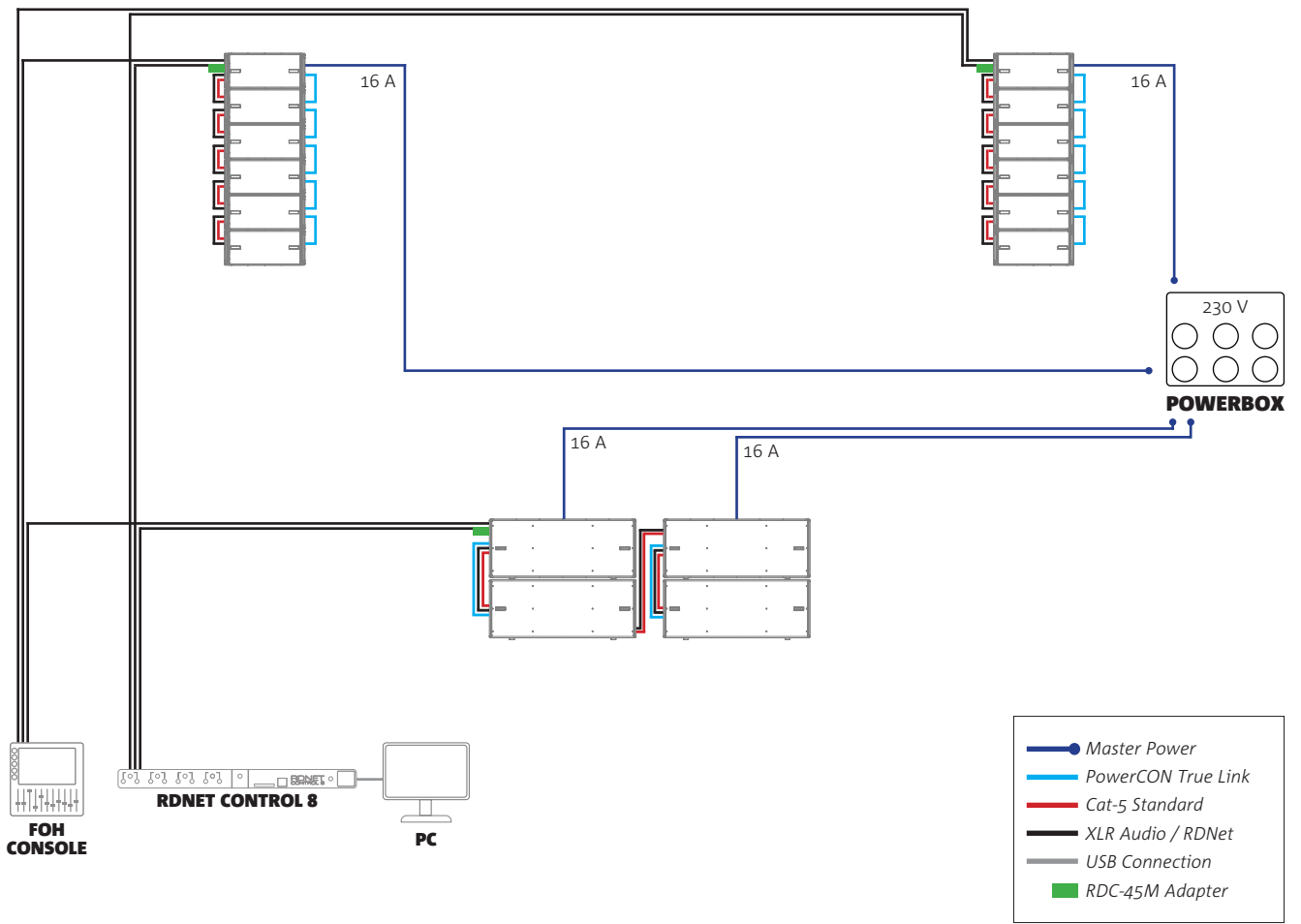

MEDIUM SYSTEM

20 x VIO L210
8 x VIO S318

DESCRIPTION

10 VIO L210 with DRK-210 suspending bar per side
Application height: 8/10 meters
Single cluster weight: 307 kg / 676 lbs (bumper included)

POWER SPECIFICATIONS - IEC60268-5

VOLTAGE	NOMINAL POWER 1/8	MAX POWER USAGE 1/3	IDLE POWER (NO SIGNAL)
230V	52.5 A - 6480 W	116.4 A - 15632 W	9.4 A - 900 W
115V	90.7 A - 6490 W	202.8 A - 16000 W	14.5 A - 844 W

SETTINGS

DSP presets, relative splay angles and subwoofer configurations are shown in dBTechnologies Composer prediction software.
CROSSOVER POINT suggested: 75 hz.

REQUIRED EQUIPMENT

QUANTITY	MODEL	DESCRIPTION
20	VIO L210	Active two-way line array module
8	VIO S318	Active high power triple 18" subwoofer
2	DRK-210	Flybar for VIO L210
16	DPTC-70L	PowerCON TRUE1 - PowerCON TRUE1 power link cable for L210 (70 cm)
4	DPTC-160L	PowerCON TRUE1 - PowerCON TRUE1 power link cable for L210 (160 cm)
22	DAC-70	XLR link cable for L210 (70 cm)
3	XLR STANDARD CABLES	Audio connection cable between subwoofer clusters
3	CAT-5 STANDARD CABLES	Cat-5 cables connection long enough for sub-config needed
18	RJ45-RJ45-75	RDNet cat-5 cables link between L210 (75 cm)
4	RJ45-RJ45-150	RDNet cat-5 cables link between S318 (150 cm)
3	RDC-45 M	RJ-45 to XLR male conversion cable, RDNet
1	RDNET CONTROL-8	8 Output RDNet master unit
8	DPTC-1000M	Master power cable to PowerCON TRUE1 (10 meters)

RECOMMENDED EQUIPMENT

QUANTITY	MODEL	DESCRIPTION
5	DT-VIOL210	Touring cart for 4x VIO L210
4	DO-VIOS318	Dolly transport for VIO S318

**SUGGESTED WIRING PLAN
FOR AVERAGE USE**

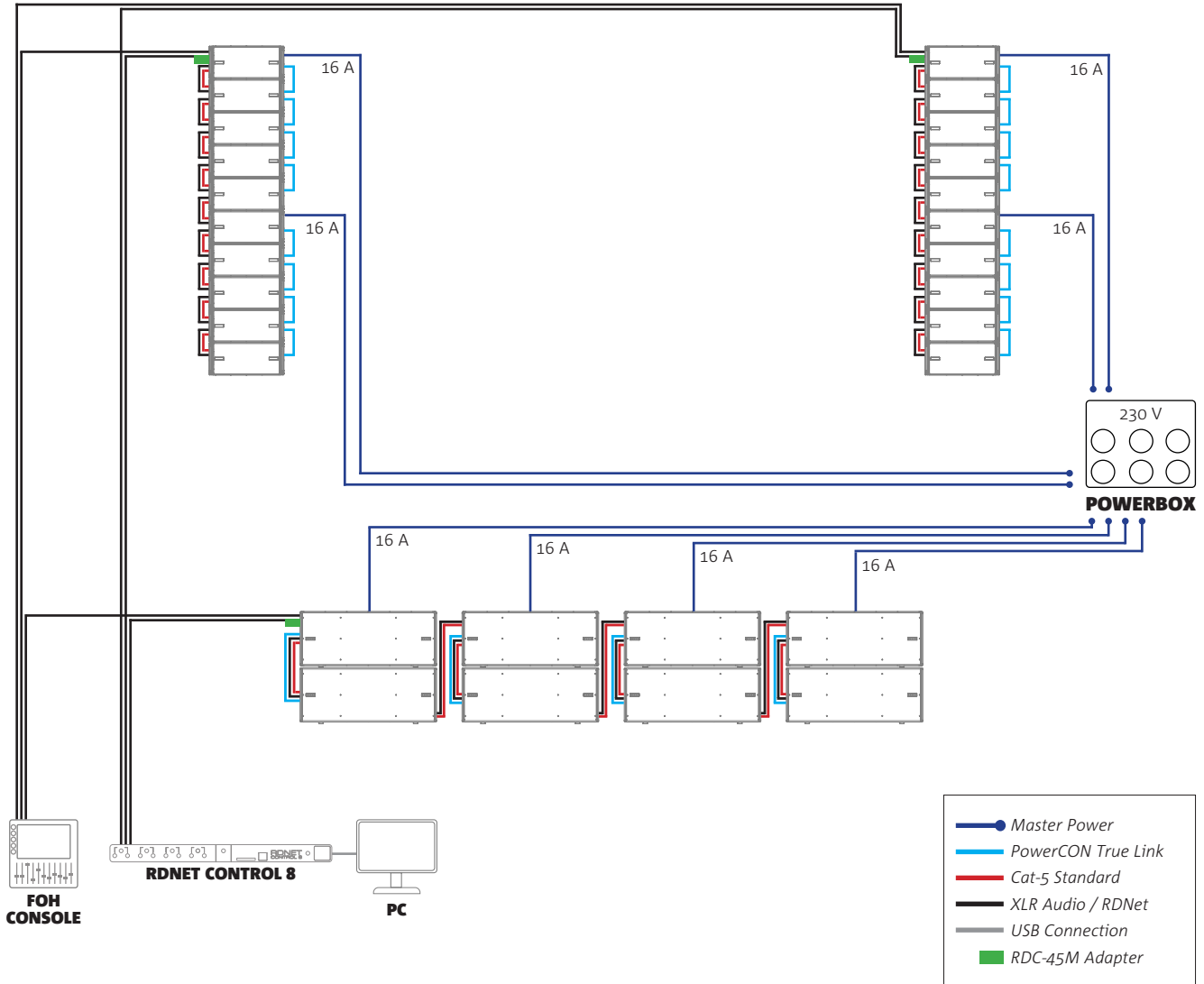

LARGE SYSTEM

32 x VIO L210
14 x VIO S318

DESCRIPTION

16 VIO L210 with DRK-210 suspending bar per side
Application height: 10/12 meters
Single cluster weight: 479 kg / 1056 lbs (bumper included)

POWER SPECIFICATIONS - IEC60268-5

VOLTAGE	NOMINAL POWER 1/8	MAX POWER USAGE 1/3	IDLE POWER (NO SIGNAL)
230V	88.2 A - 11000 W	195.6 A - 26400 W	15.6 A - 1500 W
115V	152.2 A - 11000 W	340.8 A - 27000 W	24.3 A - 1420 W

SETTINGS

DSP presets, relative splay angles and subwoofer configurations are shown in dBTechnologies Composer prediction software.
CROSSOVER POINT suggested: 70 hz.

REQUIRED EQUIPMENT

QUANTITY	MODEL	DESCRIPTION
32	VIO L210	Active two-way line array module
14	VIO S318	Active high power triple 18" subwoofer
2	DRK-210	Flybar for VIO L210
26	DPTC-70L	PowerCON TRUE1 - PowerCON TRUE1 power link cable for L210 (70 cm)
7	DPTC-160L	PowerCON TRUE1 - PowerCON TRUE1 power link cable for S318 (160 cm)
37	DAC-70	XLR link cable for L210 (70 cm)
6	XLR STANDARD CABLES	Audio connection cable between subwoofer clusters
6	CAT-5 STANDARD CABLES	Cat-5 cables connection long enough for sub-config needed
30	RJ45-RJ45-75	RDNet cat-5 cables link between L210 (75 cm)
7	RJ45-RJ45-150	RDNet cat-5 cables link between S318 (150 cm)
3	RDC-45 M	RJ-45 to XLR male conversion cable, RDNet
1	RDNET CONTROL-8	8 output RDNet master unit
13	DPTC-1000M	Master power cable to PowerCON TRUE1 (10 meters)

RECOMMENDED EQUIPMENT

QUANTITY	MODEL	DESCRIPTION
8	DT-VIOL210	Touring cart for 4x VIO L210
7	DO-VIOS318	Dolly transport for VIO S318

**SUGGESTED WIRING PLAN
FOR AVERAGE USE**

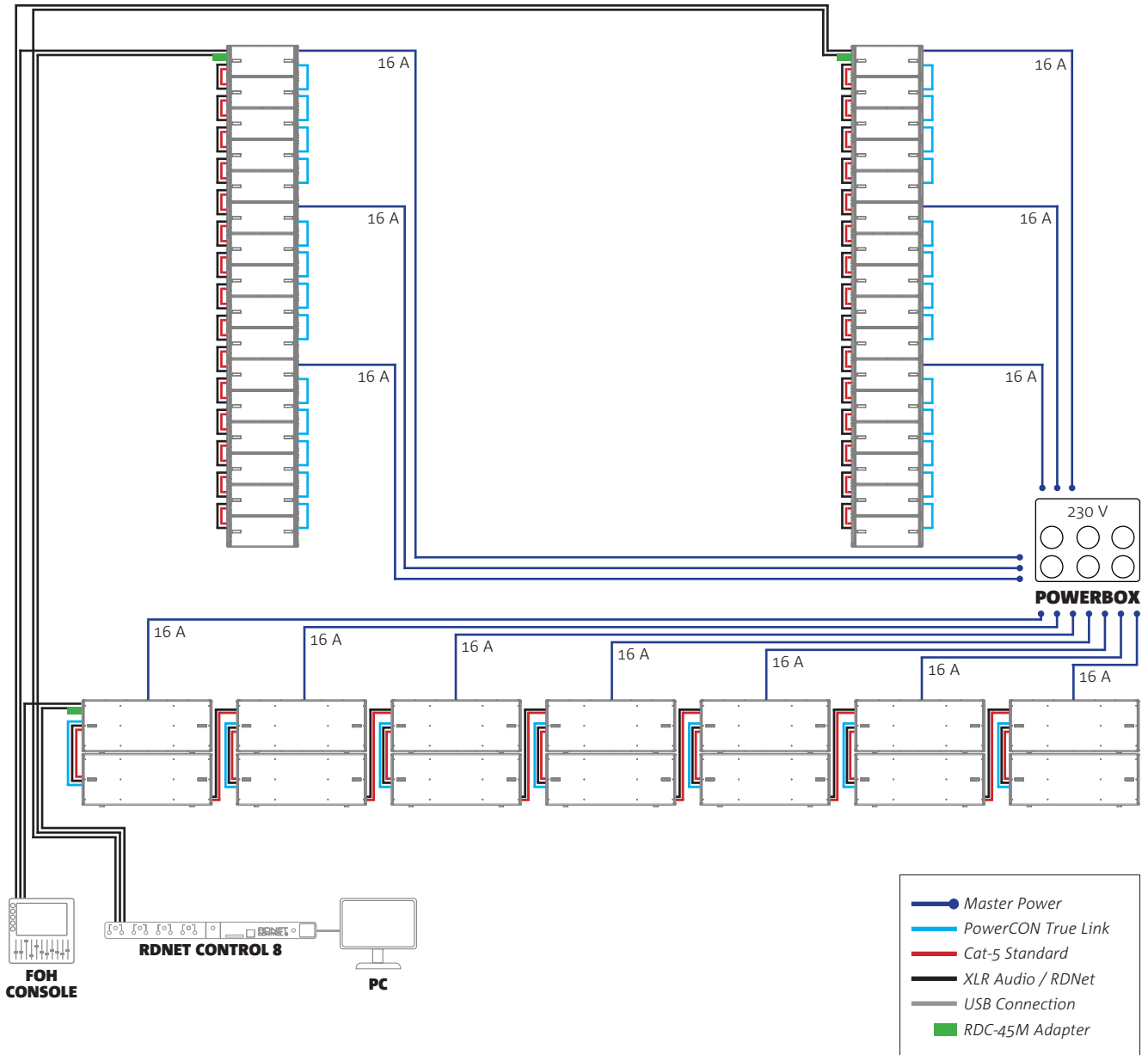

STACKED SYSTEM

8 x VIO L210
3 x VIO S318

DESCRIPTION

4 VIO L210, stacked on stage with DRK-210 per side
Application height: 2 meters, stacked on stage
Additional floor attachment system for mechanical stability is required.

POWER SPECIFICATIONS - IEC60268-5

VOLTAGE	NOMINAL POWER 1/8	MAX POWER USAGE 1/3	IDLE POWER (NO SIGNAL)
230V	20.3 A - 2500 W	47.7 A - 6022 W	3.6 A - 350 W
115V	35 A - 2500 W	78.4 A - 6150 W	5.6 A - 326 W

SETTINGS

DSP presets, relative splay angles and subwoofer configurations are shown in dBTechnologies Composer prediction software.
CROSSOVER POINT suggested: 85 hz.

REQUIRED EQUIPMENT

QUANTITY	MODEL	DESCRIPTION
8	VIO L210	Active two-way line array module
3	VIO S318	Active high power triple 18" subwoofer
2	DRK-210	Flybar for VIO L210
6	DPTC-70L	PowerCON TRUE1 - PowerCON TRUE1 power link cable for L210 (70 cm)
2	DPTC-160L	PowerCON TRUE1 - PowerCON TRUE1 power link cable for S318 (160 cm)
6	DAC-70	XLR link cable for L210 (70 cm)
2	XLR STANDARD CABLES	Audio connection cable between subwoofer clusters
2	RJ45-RJ45-150	RDNet CAT-5 cables link between S318 (150 cm)
6	RJ45-RJ45-75	RDNet cat-5 cables link between L210 (75 cm)
3	RDC-45 M	RJ-45 to XLR male conversion cable, RDNet
1	RDC-45 F	RJ-45 to XLR female conversion cable, RDNet
1	RDNET CONTROL-2	2 output RDNet master unit
4	DPTC-1000M	Master power cable to PowerCON TRUE1 (10 meters)

RECOMMENDED EQUIPMENT

QUANTITY	MODEL	DESCRIPTION
2	DT-VIOL210	Touring cart for 4x VIO L210
1	DO-VIOS318	Dolly transport for VIO S318

**SUGGESTED WIRING PLAN
FOR AVERAGE USE**

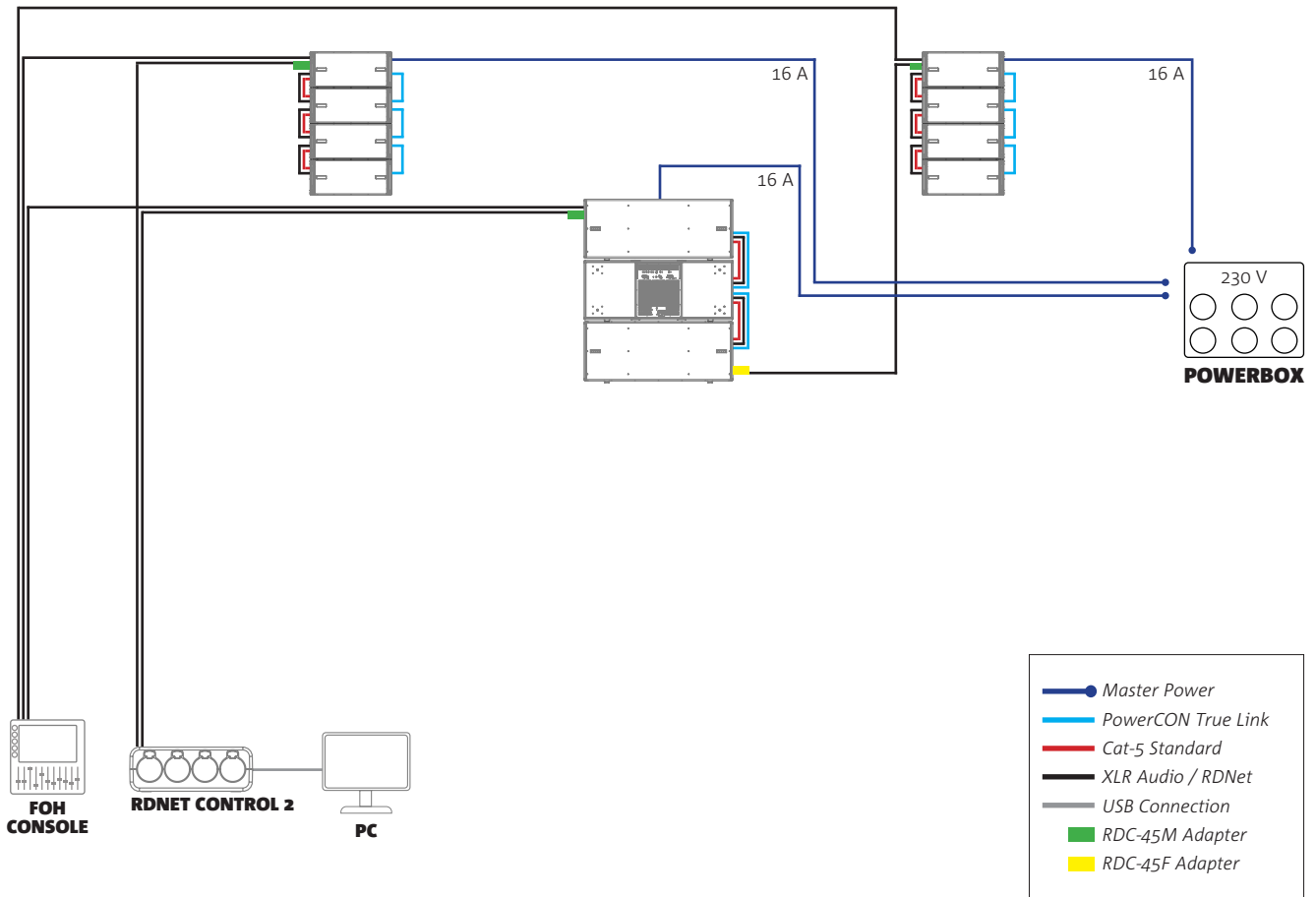

TECH SPECS

VIO L210

Speaker Type	2-Way Active Line Array Module
Usable Bandwidth [-6dB]	67 - 20.000 Hz
Frequency Response [±/- 3dB]	78 - 18.100 Hz
Max SPL	One Unit: 135 dB
HF	1 x 1.4", 3" v.c. - Neodymium, Titanium diaphragm
LF	2 x 10", 2.5" v.c. - Neodymium
Phase Correction	Aluminum Phase Plug
Horizontal Directivity	100°
Vertical Directivity	depends on array size and configuration
Amplifier	900 W RMS Class-D Digipro® G3
Cooling	Convection
Power Supply	900 W SMPS with Auto-range PSU
Controller	DSP 56 bit
AD/DA Converter	24 bit/48 kHz
Limiter	Dual Active Multiband Peak, RMS, Thermal
Processing (filters)	FIR Linear phase
Crossover Frequency LF-HF	950 Hz
Slope LF-HF	24 dB/Octave
Signal Input	1x XLR female, balanced
Signal Output	1x XLR male, balanced
Network	RDNet remote control RJ45 connector IN/OUT
Power Socket	1x PowerCON TRUE1 In 1x PowerCON TRUE1 Out
Controls	1 x Speaker Coupling (7 presets) 1 x HF Compensation (8 presets) 1 x Input Attenuation Rotary Switch
Housing	Multiplex plywood - Polyurea painting
Housing Design	Trapezoidal 10°
Handles	1 x Side, 2 on back
Rain cover	Included
Rigging Points	Integrated rigging hardware
Width x Height x Depth	720 x 320 x 520 mm (28.35 x 12.6 x 20.47 in)
Weight	28.6 kg (63 lbs)



TECH SPECS

VIO S318

Speaker Type	Active Bassreflex, semi-horn loaded subwoofer
Frequency Response [-6dB]	39 Hz to cut frequency (Xover dependent)
Frequency Response [-10dB]	35 Hz (HPF)
Max SPL	143 dB
LF	3x18"
Voice Coil LF	4"
Directivity	Omnidirectional
Amplifier	2700 W RMS Class-D Digipro® G3
Cooling	Convection
Power Supply	2700 W SMPS with Auto-range PSU
Controller	DSP 64 bit
AD/DA Converter	24 bit/96 kHz
 Limiter	Peak, RMS, Thermal
Delay Option	0-9.9 ms internal steps of 0.1 ms
Crossover Frequency LF-HF	70-105 Hz + Full Range
LF-Xover out slope	24 dB/Octave
Signal Input	1 x XLR balanced, 1 x RJ45 Link (RDNet)
Signal Output	1x XLR balanced, 1 x RJ45 Link (RDNet)
Power Socket	1x PowerCON TRUE1 In 1x PowerCON TRUE1 Out
Controls	1x Input Attenuation Rotary Encoder 2x Rotary Encoder (Delay 9.9 ms) 1x Polarity Inversion Switch (0° or 180°) 1x Cardioid mode Switch 1x X-Over Frequency Switch (70-105 Hz + Full-Range steps of 5 Hz)
Housing	Multiplex plywood - Polyurea painting
Additional Features	4x Eyelets for ratchet straps
Handles	4x Side. Aluminium
Rain cover	Included
Rigging Points	2x Pick Points on top to fix DRK-210 rigging frame
Width x Height x Depth	1300 x 520 x 800 mm (51.18 x 20.47 x 31.5 in)
Weight	103.9 kg (229.06 lbs)

ACCESSORIES

TRANSPORT & INSTALLATION

DO-VIOS318

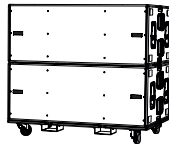

Dolly for up to 3x VIO S318 Stacked horizontally (wheels included).

DRK-210



Flybar for VIO L210. Suitable for fly and stack use.

DT-VIOL210

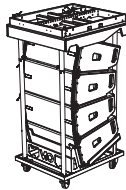

Touring cart for 4 VIO L210 modules and a DRK-210 flybar. Including 4 poles and a wooden lid.

SWK-18 KIT

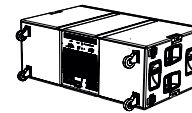

Kit consisting of 4 wheels for VIO S318 back panel.

BAGS & COVERS

FC-VIOS1

Functional cover for VIO S318. Waterproof.

TC-VIOL210

Transport cover for DT-VIOL210. Waterproof.

TC-VIOS2

Transport cover for two VIO S318. Waterproof.

CABLES

DAC-70

XLR-XLR audio cable (70 cm).

DCK-27T

Cable-Set for VIO L210 / S318 containing 2x DAC-70 and 2x DPTC-70L.

DPTC-70L

PowerCON TRUE1-PowerCON TRUE1 power link cable (70cm).

DPTC-160L

PowerCON TRUE1-PowerCON TRUE1 power link cable (160cm) for VIO S318.

DPTC-1000M

Mains PowerCON TRUE1 cable (10m). Different plugs available for several countries.

RDC-45F

RJ45 to XLR 3 poles female conversion cable, 6 cm length. The cable converts from RDNet RJ45 to XLR.

RDC-45M

RJ45 to XLR 3 poles male conversion cable, 6 cm length. The cable converts from RDNet RJ45 to XLR.

RJ45-RJ45-150

RJ45-RJ45 link cable (150cm) for RDNet speakers. EtherCON connectors.

RJ45-RJ45-75

RJ45-RJ45 link cable (75cm) for RDNet speakers. EtherCON connectors.

SMARTER LIGHTER FASTER STRONGER

dBTechnologies

Italy & International sales

AEB Industriale Srl

Via Brodolini, 8 - Loc. Crespellano

40053 Valsamoggia (BO) ITALY

Tel +39 051 96 98 70

Fax +39 051 96 97 25

info@dbtechnologies-aeb.com

dBTechnologies Deutschland GmbH

Germany, Belgium, Netherlands,

Luxembourg, Austria

Hansestrasse 93

51149 Köln

Tel. +49 (0)2203 925370

Fax. +49 (0)2203 9253773

verkauf@dbtechnologies.de

V.1 ENG