

COLORADO 1 SOLO

User Manual

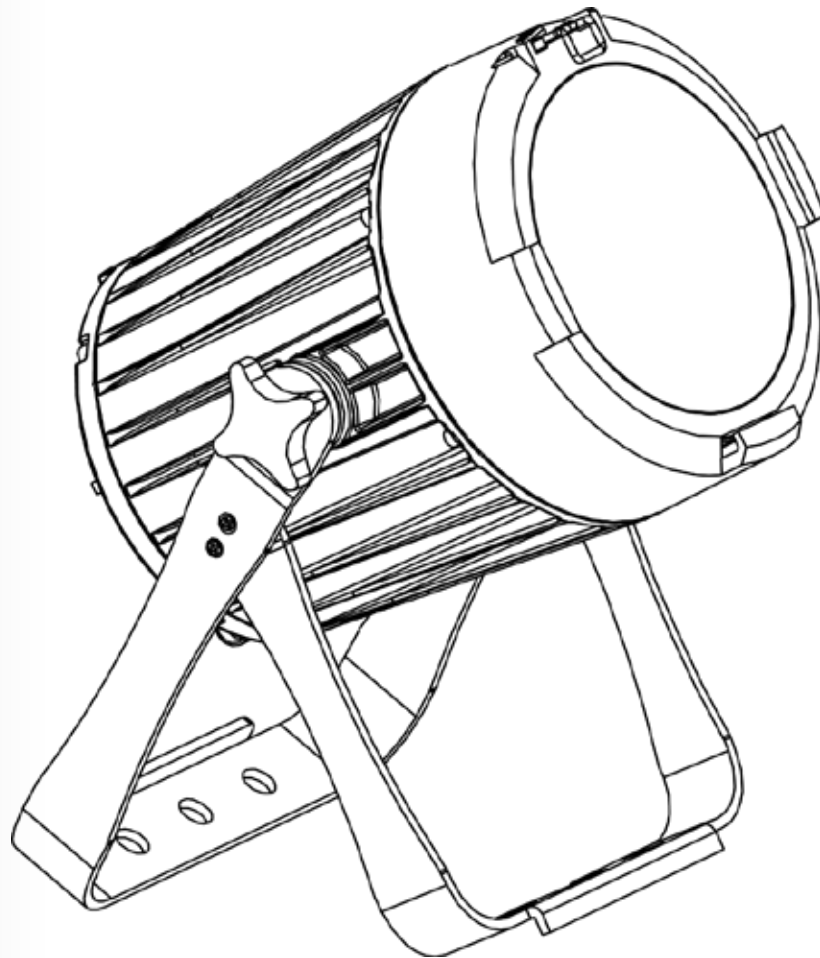

CHAUVET
PROFESSIONAL

Edition Notes The COLORado 1 Solo User Manual Rev. 6 includes a description, safety precautions, and installation, programming, operation, and maintenance instructions for the COLORado 1 Solo as of the release date of this edition in April 2018.

Trademarks CHAUVET, the Chauvet logo and COLORado 1 Solo are registered trademarks or trademarks of Chauvet & Sons LLC. (d/b/a Chauvet and Chauvet Lighting) in the United States and other countries. Other company and product names and logos referred to herein may be trademarks of their respective companies.

Copyright Notice The works of authorship contained in this manual, including, but not limited to, all design, text and images are owned by Chauvet.

© **Copyright 2018 Chauvet & Sons, LLC. All rights reserved.**

Electronically published by Chauvet in the United States of America.

Manual Use Chauvet authorizes its customers to download and print this manual for professional information purposes only. Chauvet expressly prohibits the usage, copy, storage, distribution, modification, or printing of this manual or its content for any other purpose without written consent from Chauvet.

Document Printing For better results, print this document in color, on letter size paper (8.5 x 11 in), double-sided. If using A4 paper (210 x 297 mm), configure your printer to scale the content accordingly.

Intended Audience Any person in charge of installing, operating, and/or maintaining this product should completely read through the guide that shipped with the product, as well as this manual, before installing, operating, or maintaining this product.

Disclaimer Chauvet believes that the information contained in this manual is accurate in all respects. However, Chauvet assumes no responsibility and specifically disclaims any and all liability to any party for any loss, damage or disruption caused by any errors or omissions in this document, whether such errors or omissions result from negligence, accident or any other cause. Chauvet reserves the right to revise the content of this document without any obligation to notify any person or company of such revision, however, Chauvet has no obligation to make, and does not commit to make, any such revisions..

Document Revision The COLORado 1 Solo User Manual Rev. 6 supersedes all previous versions of this manual. Discard any older versions of this manual and replace with this version. Go to www.chauvetprofessional.com for the latest version.

Table of Contents

| | |
|--------------------------------------|----------|
| 1. Before You Begin | 1 |
| What Is Included | 1 |
| Claims | 1 |
| Manual Conventions | 1 |
| Symbols | 1 |
| Safety Notes | 2 |
| Personal Safety..... | 2 |
| Mounting And Rigging..... | 2 |
| Power And Wiring | 2 |
| Operation | 2 |
| Expected LED Lifespan | 2 |
| 2. Introduction | 3 |
| Description | 3 |
| Features..... | 3 |
| Overview | 4 |
| Dimensions | 5 |
| 3. Setup..... | 6 |
| AC Power..... | 6 |
| AC Plug..... | 6 |
| Power Linking..... | 6 |
| DMX Linking..... | 7 |
| DMX Personalities..... | 7 |
| Remote Device Management (RDM) | 7 |
| Master/Slave Connectivity..... | 7 |
| Mounting | 8 |
| Orientation | 8 |
| Rigging..... | 8 |
| Procedure | 8 |
| 4. Operation | 9 |
| Control Panel Description | 9 |
| Control Options..... | 9 |
| Programming | 9 |
| Control Panel Lock | 9 |
| Passcode | 9 |
| Menu Map | 10 |
| Menu Map (Cont.)..... | 11 |
| Configuration (Standalone)..... | 12 |
| Auto Programs | 12 |
| Edit Custom Programs..... | 12 |
| Master/Slave | 12 |
| Dimmer Profiles..... | 13 |
| Program Upload..... | 13 |
| Reset..... | 13 |
| Whites Setting..... | 14 |
| Static Color | 14 |
| Color Temperature Settings | 14 |
| Zoom Mode..... | 14 |
| LED Frequency | 14 |
| Software Information..... | 14 |
| RDM..... | 14 |
| Configuration (DMX) | 15 |
| DMX Personalities..... | 15 |
| DMX Control..... | 15 |

| | |
|---|-----------|
| Loss Of Signal Setting..... | 15 |
| TOUR Notes | 16 |
| Master Dimmer..... | 16 |
| Red, Green, Blue, and White Color Selection | 16 |
| Color Macros..... | 16 |
| Strobe | 16 |
| Auto/Custom | 16 |
| Zoom..... | 16 |
| Dimmer Speed | 16 |
| DMX Values | 17 |
| DMX Values (Cont.)..... | 18 |
| DMX Values (Cont.)..... | 19 |
| DMX Values (Cont.)..... | 20 |
| DMX Values (Cont.)..... | 21 |
| DMX Values (Cont.)..... | 22 |
| DMX Values (Cont.)..... | 23 |
| DMX Values (Cont.)..... | 24 |
| 5. Technical Information | 25 |
| Product Maintenance..... | 25 |
| 6. Technical Specifications..... | 26 |
| Returns | 27 |
| Contact Us | 28 |

1. Before You Begin



- What Is Included**
- COLORado 1 Solo
 - Seetronic Powerkon IP65 power cord
 - Warranty Card
 - Quick Reference Guide

Claims Carefully unpack the product immediately and check the box to make sure all the parts are in the package and are in good condition. If the box or the contents (the product and included accessories) appear damaged from shipping or show signs of mishandling, notify the carrier immediately, not Chauvet. Failure to report damage to the carrier immediately may invalidate your claim. In addition, keep the box and contents for inspection. For other issues, such as missing components or parts, damage not related to shipping, or concealed damage, file a claim with Chauvet within 7 days of delivery.

Manual Conventions

| Convention | Meaning |
|---------------|--|
| 1–512 | A range of values in the text |
| 50/60 | A set of mutually exclusive values in the text |
| <SET> | A button on the product’s control panel |
| Settings | A product function or a menu option |
| MENU>Settings | A sequence of menu options |
| 1–10 | A range of menu values from which to choose in a menu |
| Yes/No | A set of two mutually exclusive menu options in a menu |
| ON | A unique value to be entered or selected in a menu |

Symbols

| Symbols | Meaning |
|---|---|
|  | Critical installation, configuration, or operation information. Failure to comply with this information may cause the product not to work, damage third-party equipment, or cause harm to the operator. |
|  | Important installation or configuration information. Failure to comply with this information may keep the product from working. |
|  | Useful information. |



The term “DMX” used throughout this manual refers to the USITT DMX512-A digital data transmission protocol.



Any reference to data or power connections in this manual assumes the use of Seetronic IP rated cables

Safety Notes

Read all the following Safety Notes before working with this product. These notes include important information about the installation, usage, and maintenance of this product.



This product contains no user-serviceable parts. Any reference to servicing in this User Manual will only apply to properly trained Chauvet certified technicians. Do not open the housing or attempt any repairs.



All applicable local codes and regulations apply to proper installation of this product.

Personal Safety

- Avoid direct eye exposure to the light source while the product is on.
- Always disconnect this product from its power source before servicing.
- Always connect this product to a grounded circuit to avoid the risk of electrocution.
- Do not touch this product's housing during operation because it may be very hot.
- Do not submerge this product (IP65). Temporary outdoor operation is fine.
- Do not allow the product to remain pointed straight down if using in below freezing temperatures.
- CAUTION: When transferring product from extreme temperature environments, (e.g. cold truck to warm humid ballroom) condensation may form on the internal electronics of the product. To avoid causing a failure, allow product to fully acclimate to the surrounding environment before connecting it to power.
- Not for permanent outdoor installation in locations with extreme environmental conditions. This includes, but is not limited to:

- Exposure to a marine/saline environment (within 3 miles of a saltwater body of water).
- Where the normal high or low temperatures of the location exceed the temperature ranges in this manual.
- Locations that are prone to flooding or being buried in snow.
- Other areas where the product will be subject to extreme radiation or caustic substances.

Mounting And Rigging

- Mount this product in a location with adequate ventilation, at least 20 in (50 cm) from adjacent surfaces.
- Make sure there are no flammable materials close to this product while it is operating.
- When hanging this product, always secure to a fastening device using a safety cable.

Power And Wiring

- Always make sure you are connecting this product to the proper voltage in accordance with the specifications in this manual or on the product's specification label.
- To eliminate unnecessary wear and improve its lifespan, during periods of non-use completely disconnect the product from power via breaker or by unplugging it.
- Never connect this product to a dimmer pack or rheostat.
- Never disconnect this product by pulling or tugging on the power cable.

Operation

- Do not operate this product if you see damage on the housing, lenses, or cables. Have the damaged parts replaced by an authorized technician at once.
- Do not cover the ventilation slots when operating to avoid internal overheating.
- The maximum ambient temperature is 113 °F (45 °C). Do not operate this product at a higher temperature.
- In case of a serious operating problem, stop using this product immediately!



Expected LED Lifespan

In the unlikely event that your Chauvet product requires service, contact Chauvet Technical Support.

LEDs gradually decline in brightness over time, mostly because of heat. Packaged in clusters, LEDs exhibit higher operating temperatures than in ideal, single-LED conditions. For this reason, using clustered LEDs at their fullest intensity significantly reduces the LEDs' lifespan. Under normal conditions, this lifespan can be 40,000 to 50,000 hours. If extending this lifespan is vital, lower the operating temperature by improving the ventilation around the product and reducing the ambient temperature to an optimal operating range. In addition, limiting the overall projection intensity may also help to extend the LEDs' lifespan.

2. Introduction

Description The COLORado 1 Solo is an IP65-rated high-power quad-color (RGBW) LED wash product with color mixing and zoom control. This powerful wash product projects an even, fully homogenized beam through fast and smooth zooming optics. The COLORado 1 Solo features new IP rated power and data connectors, full convection cooling, and a double-bracketed yoke that can serve as a floor mount or hanging support bracket.

- Features**
- 9, 12 or 17-channel quad-color LED wash product
 - Operating modes:
 - 9-channel: H/S/CCT control, dimmer, strobe, zoom, zoom reset, dimmer speed
 - 9-channel: R/G/B/W, dimmer, strobe, zoom, zoom reset, dimmer speed
 - 12-channel: R/G/B/W, dimmer, strobe, color macro, auto/custom, dimmer speed, auto speed, zoom, zoom reset
 - 17-channel: 16-bit R/G/B/W and dimmer; strobe, color macro, auto/custom, dimmer speed, auto speed, zoom, zoom reset
 - 17-channel: 16-bit R/G/B/W and dimmer; strobe, color macro, auto/custom, dimmer speed, auto speed, zoom, zoom reset
 - Zooming RGBW LED wash for touring, rental and production indoors or out
 - Completely homogenized wash with superior color mixing and zoom
 - 8° to 55° smooth and fast zoom
 - All environment operation with IP rated power and DMX connections
 - Color temperature presets, from 3200 K to 10000 K
 - Selectable, smooth dimming curves for programming versatility
 - OLED display with password protection

Overview

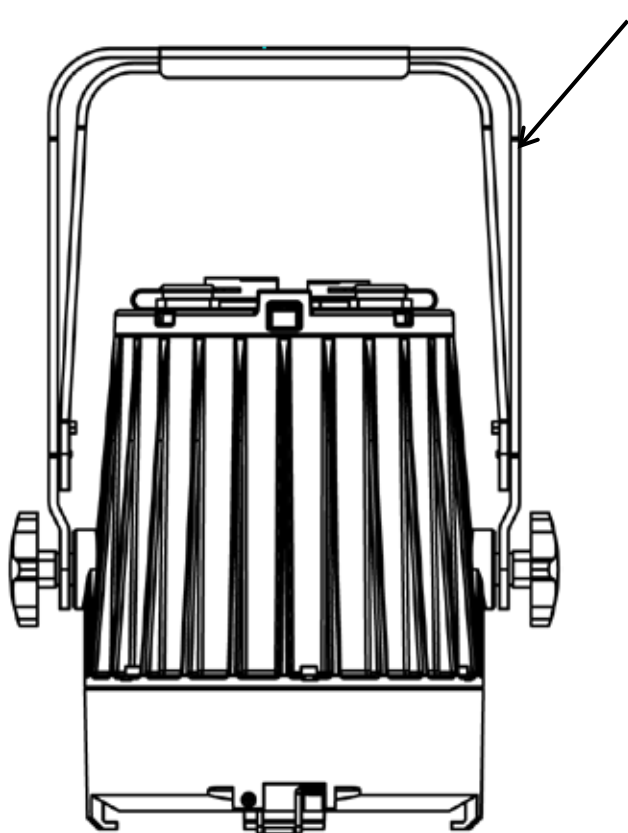

Top View

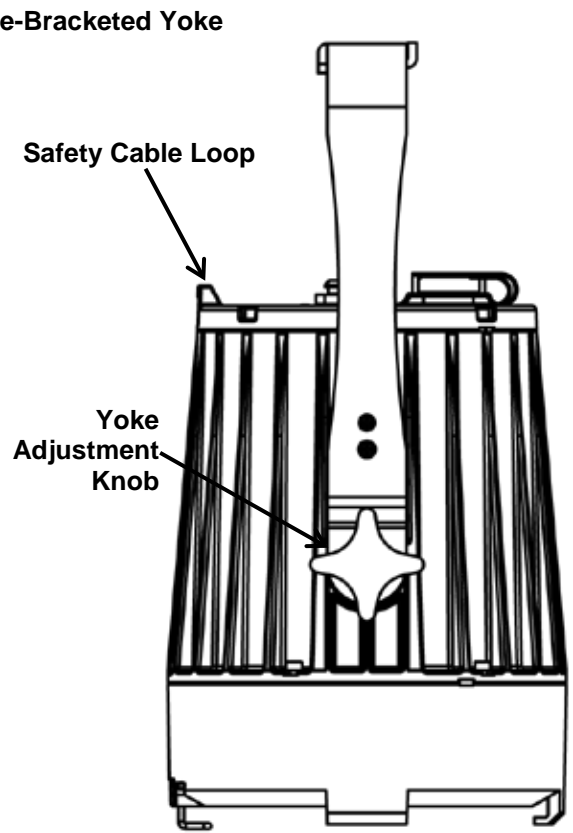

Side View

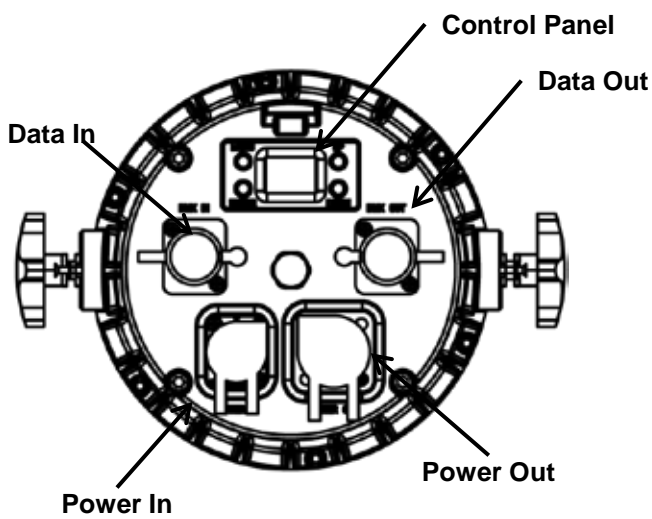

Rear View

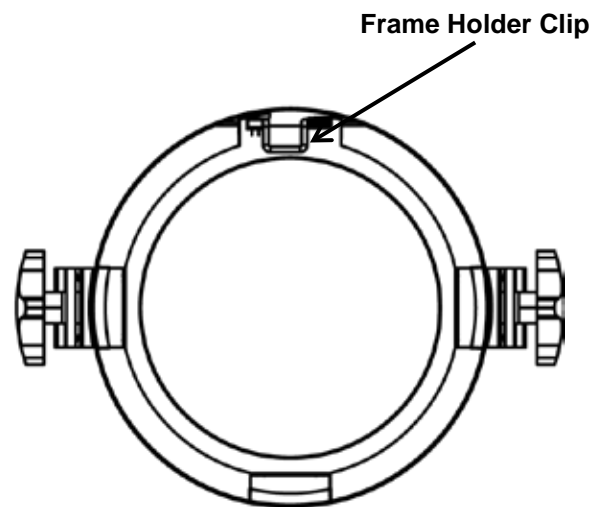

Front View

Dimensions

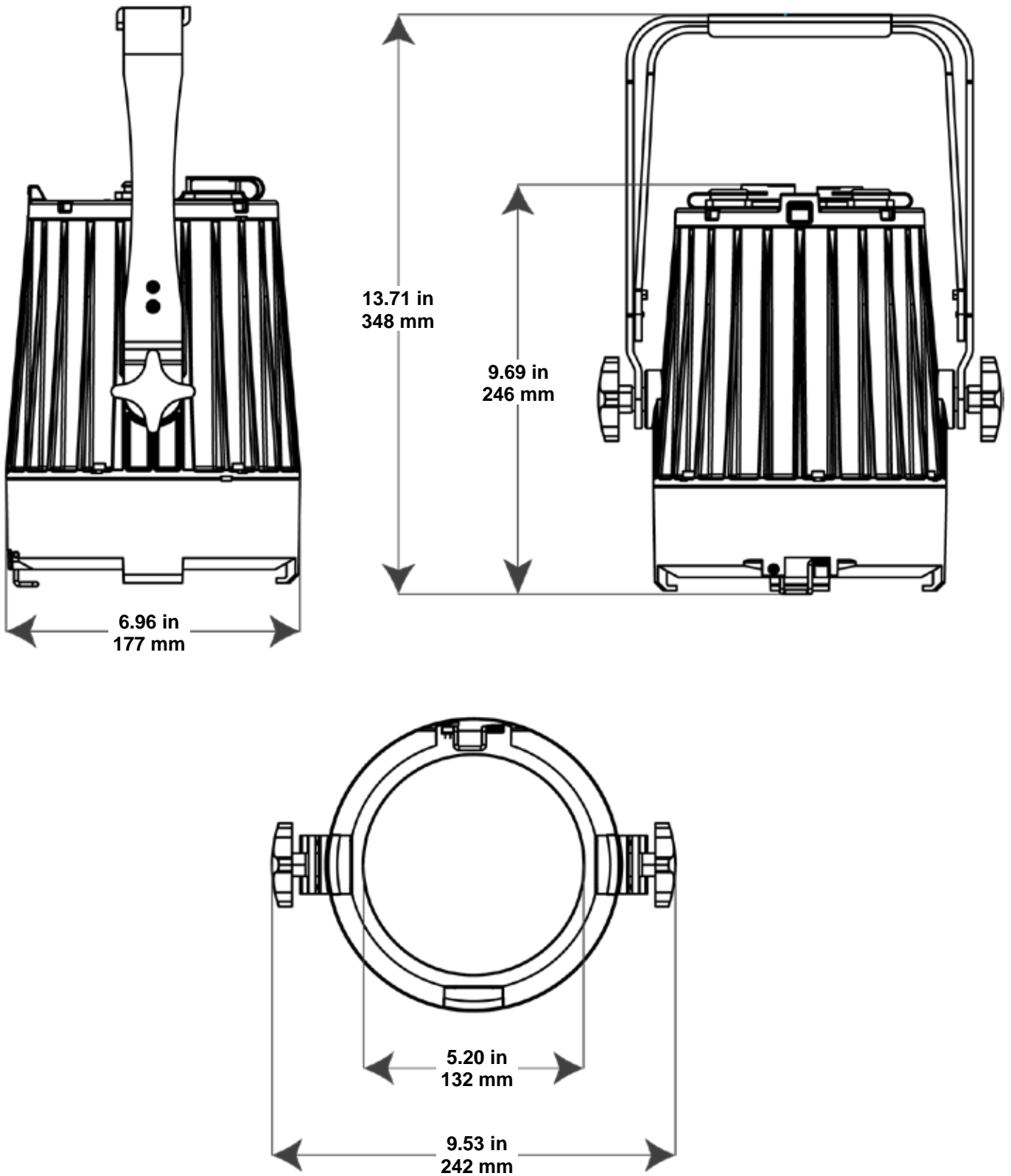

3. Setup

AC Power

Each COLORado 1 Solo has an auto-ranging power supply that works with an input voltage range of 100 to 240 VAC, 50/60 Hz. To determine the power requirements for each COLORado 1 Solo, refer to the label affixed to the product. You can also refer to the [Technical Specifications](#) chart in this manual.

The listed current rating indicates the maximum current draw during normal operation. For more information, you may download Sizing Circuit Breakers from the Chauvet website: www.chauvetprofessional.com.



- **Always connect this product to a protected circuit with an appropriate electrical ground to avoid the risk of electrocution or fire.**
- **To eliminate unnecessary wear and improve its lifespan, during periods of non-use completely disconnect the product from power via breaker or by unplugging it.**



Never connect this product to a rheostat (variable resistor) or dimmer circuit, even if the rheostat or dimmer channel serves only as a 0 to 100% switch.

AC Plug

The COLORado 1 Solo comes with a power input cord terminated with a Seetronic Powerkon A connector on one end and an Edison plug on the other end (U.S. market). If the power input cord that came with your product has no plug, or if you need to change the Edison plug, use the table below to wire the new plug.

| Connection | Wire (U.S.) | Wire (Europe) | Screw Color |
|------------|--------------|---------------|-----------------|
| AC Live | Black | Brown | Yellow or Brass |
| AC Neutral | White | Blue | Silver |
| AC Ground | Green/Yellow | Green/Yellow | Green |

Power Linking

The COLORado 1 Solo supports power linking. You can power link up to 24 products at 120 V; up to 40 at 208 V; or up to 45 at 230 V. This product comes with a power input cord.



- **To preserve the IP65 rating and the warranty of this product, Seetronic Powerkon cables must be used.**
- **Insert the attached IP65 rated plugs into the corresponding power/data connections when not in use.**

DMX Linking You can link the COLORado 1 Solo to a DMX controller using a 5-pin DMX connection. If using other DMX-compatible products with the COLORado 1 Solo, you can control each individually with a single DMX controller.

DMX Personalities The COLORado 1 Solo uses a 5-pin DMX data connection for the **HSIC, SSP, TOUR, TR16,** and **STD.Y** DMX personalities.

- Refer to the [Introduction](#) chapter for a brief description of each DMX personality.
- Refer to the [Operation](#) chapter to learn how to configure the COLORado 1 Solo to work in these personalities.
- The [DMX Values](#) section provides you with detailed information regarding the DMX personalities.



- **If you are not familiar with or need more information about DMX standards, Master/Slave connectivity, or the DMX cables needed to link this product to a DMX controller, download the DMX Primer from the Chauvet website: www.chauvetprofessional.com.**
- **For optimum control of the 16-bit dimming channels in the TR16 and STD.Y personalities, be sure that both dimming curves in SETTING > DIMMER are set to OFF.**

Remote Device Management (RDM) Remote Device Management, or RDM, is a standard for allowing DMX-enabled devices to communicate bi-directionally along existing DMX cabling. Check the DMX controller's User Manual or with the manufacturer as not all DMX controllers have this capability. The COLORado 1 Solo supports RDM protocol that allows feedback to make changes to menu map options.

Master/Slave Connectivity The Master/Slave mode allows a COLORado 1 Solo (the master) to control one or more COLORado 1 Solos (the slaves) without a DMX controller. One COLORado 1 Solo becomes the master when running an auto or custom program, or by being in a Static mode. You must configure each slave's control panel to operate in Slave mode. During Master/Slave operation, the slaves will operate in unison with the master.



DO NOT connect a DMX controller to products operating in Master/Slave mode. The DMX controller signals may interfere with the signals from the master.



- The [Operation](#) section of this manual provides detailed instructions on how to configure the master and slaves.
- **If you are not familiar with or need more information about DMX standards, or the DMX cables needed to link this product to a DMX controller, download the DMX Primer from the Chauvet website: www.chauvetprofessional.com.**
- **To preserve the IP65 rating and the warranty of this product, IP65 data cables must be used.**
- **Insert the attached IP65 rated plugs into the corresponding power/data connections when not in use.**



- Mounting** Before mounting this product, read and follow the [Safety Notes](#). For our CHAUVET Professional line of mounting clamps, go to <http://trusst.com/products/>.
- Orientation** Always mount this product in a safe position and make sure there is adequate room for ventilation, configuration, and maintenance.
- Rigging** Chauvet recommends using the following general guidelines when mounting this product.
- When selecting an installation location, consider easy access to this product for operation, programming adjustments, and routine maintenance.
 - Make sure to mount this product away from any flammable material as indicated in the [Safety Notes](#).
 - If hanging this product, make sure that the mounting location can support the product's weight. See the [Technical Specifications](#) for the weight-bearing requirements of this product.
 - When hanging this product, always secure to a fastening device using a safety cable. For our CHAUVET Professional line of safety cables, go to <http://trusst.com/products/>.
- Procedure** The COLORado 1 Solo comes with a double-bracketed yoke to which you can either attach mounting clamps for hanging or simply use as a floor stand. You must supply your own mounting clamps. Make sure the clamps are capable of supporting the weight of this product. Use at least one mounting point per product. For our CHAUVET Professional line of mounting clamps, go to <http://trusst.com/products/>.

Mounting Diagram

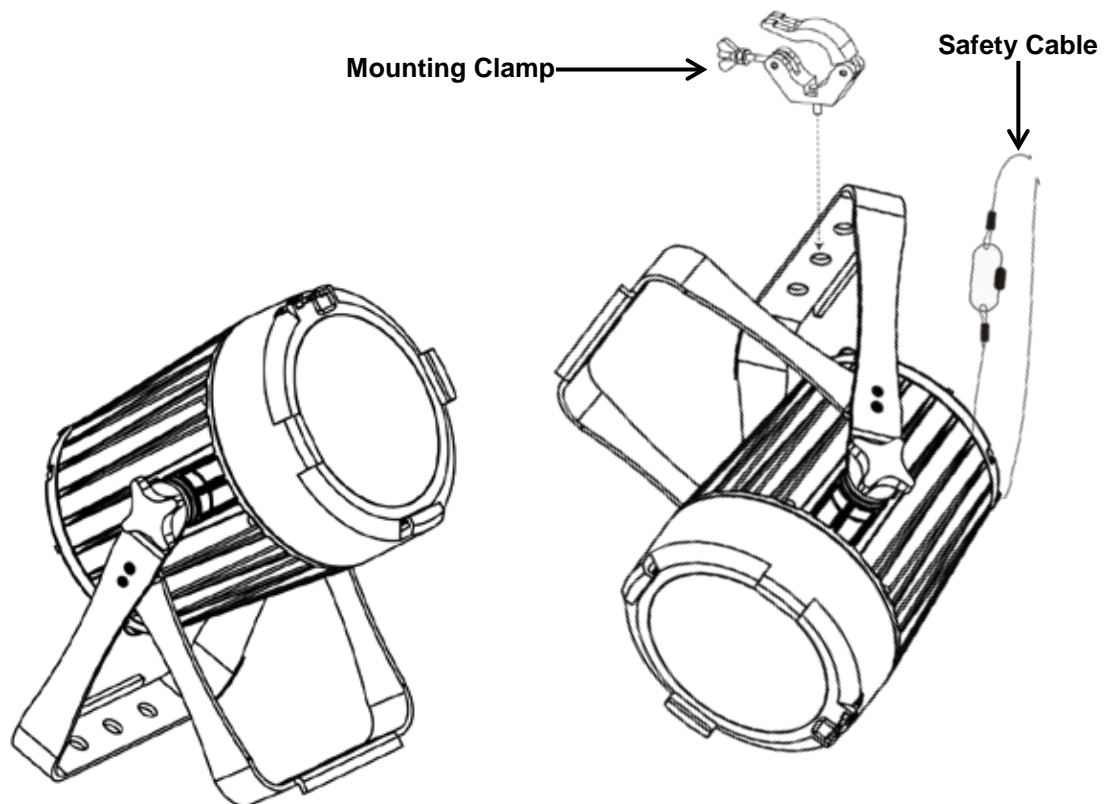

Floor Mounting

Overhead Mounting



When using only one mounting clamp, be sure to use a clamp with a captive bolt to prevent accidental loosening.

4. Operation

| Control Panel Description | Button | Function |
|---------------------------|---------|--|
| | <MENU> | Exits from the current menu or function |
| | <ENTER> | Enables the currently displayed menu or sets the currently selected value in to the current function |
| | <UP> | Navigates upward through the menu list or increases the numeric value when in a function |
| | <DOWN> | Navigates downward through the menu list or decreases the numeric value when in a function |

Control Options Set the COLORado 1 Solo starting address in the **001–512** DMX range. This enables control of up to 30 products in the 17-channel **TR16** personality.

Programming Refer to the [Menu Map](#) to understand the menu options. The menu map shows the main level and a variable number of programming levels for each option.

- To go to the desired main level, press **<MENU>** repeatedly until the option shows on the display. Press **<ENTER>** to select. This will take you to the first programming level for that option.
- To select an option or value within the current programming level, press **<UP>** or **<DOWN>** until the option shows on the display. Press **<ENTER>** to select. In this case, if there is another programming level, you will see that first option, or you will see the selected value.
- Press **<MENU>** repeatedly to exit to the previous main level.

Control Panel Lock This setting enables you to activate or disable the control panel lock, which keeps non-authorized personnel from changing the product's settings.

1. Go to the **KEY** main level.
2. Select **ON** or **OFF**.



When the control panel lock is activated, in order to access the products main programming level, the product will prompt you to enter the passcode. Enter the passcode as described in [Passcode](#).

Passcode After being prompted to enter the passcode:

- Press **<UP>**, **<DOWN>**, **<UP>**, **<DOWN>**, **<ENTER>**.

Menu Map

| Main Level | Programming Levels | | | Description | |
|--------------|--------------------|----------------|--------|--|--|
| STATIC | | | RED | 000–255 | Combines red, green, blue, and white to make a custom color (0–100%) |
| | | | GREEN | | |
| | | | BLUE | | |
| | | | WHITE | | |
| | | | ZOOM | | Changes the beam angle (zoom) |
| | | | STROBE | | Selects the strobe frequency (0–25 Hz) |
| ADDRESS | 001–512 | | | Selects the DMX starting address | |
| AUTO PROGRAM | AUTO1-10 | Speed 000–255 | | 10 automatic programs | |
| | PROGRAM1-10 | | | 10 customizable programs | |
| RUN MODE | DMX | | | DMX mode | |
| | SLAVE | | | Master/Slave mode | |
| ZOOM MODE | ZOOM MODE 1 | | | Normal operation | |
| | ZOOM MODE 2 | | | Recommended for use Below 40 °F | |
| PERSONALITY | HSIC | | | 9-channel: H/S/CCT control, dimmer, strobe, zoom, zoom reset, dimmer speed | |
| | SSP | | | 9-channel: R/G/B/W, dimmer, strobe, zoom, zoom reset, dimmer speed | |
| | TOUR | | | 12-channel: R/G/B/W, dimmer, strobe, color macro, auto/custom, dimmer speed, auto speed, zoom, zoom reset | |
| | TR16 | | | 17-channel: 16-bit RGBW and dimmer; strobe, color macro, auto/custom, dimmer speed, auto speed, zoom, zoom reset | |
| | STD.Y | | | 17-channel: 16-bit RGBW and dimmer; strobe, color macro, auto/custom, dimmer speed, auto speed, zoom, zoom reset | |
| EDIT | PROGRAM 01-10 | SCENE 01–30 | RED | 000– 255 | Combines red, green, blue, and white to make a custom color (0-100%) |
| | | | GREEN | | |
| | | | BLUE | | |
| | | | WHITE | | |
| | | | ZOOM | | Changes the beam angle (zoom) |
| | | | STROBE | | Selects the strobe frequency (0–25 Hz) |
| | | | TIME | | Defines the step duration (slow to fast) |
| | | | FADE | | Defines the fade duration (slow to fast) |

Menu Map (Cont.)

| Main Level | Programming Levels | | | | Description | |
|------------|--------------------------|----------------|--------------------------|--|---|--|
| SETTING | **** (Enter Passcode) | UPLOAD | **** (Enter Passcode) | SEND | Uploads custom programs to other COLORado 1 Solo products | |
| | | RESET | **** (Enter Passcode) | | Defaults product to factory settings | |
| | | DIMMER | OFF | | | No dimmer |
| | | | DIM4 | | | Selects dimming profiles from fast (DIM1) to slow (DIM4) or OFF |
| | | | DIM3 | | | |
| | | | DIM2 | | | |
| | | DIM1 | | | | |
| | | DMX ERROR | SAVE | | | Continues with last command upon loss of DMX control |
| | | | BLACK | | | Blacks out fixture upon loss of DMX |
| | | PWM | 600Hz | | | Selects the PWM output frequency |
| | | | 1200Hz | | | |
| | | | 2000Hz | | | |
| | | | 2400Hz | | | |
| | | | 6000Hz | | | |
| | | | 18000Hz | | | |
| | | | 25000Hz | | | |
| | | FULL POWER CCT | WARM WHITE | | | Sets the color temperature when all color faders are set to 100% |
| | | | NEUTRAL WHITE | | | |
| | | | COOL WHITE#1 | | | |
| | | | COOL WHITE#2 | | | |
| XY OFFSET | NORMAL | | | Manual color temperature | | |
| | HIDE | | | Shows and hides XY settings in PWM menu option | | |
| SHOW | | | | | | |
| KEY | ON | | | | Turns the passcode on or off | |
| | OFF | | | | | |
| CALIB.C | **** (Enter Passcode) | WHITE | WHITE 01-13 | X FINE Y FINE | +/-200 | Modifies the color macros used in the TOUR , TR16 , HSIC , and STD.Y personality |
| INFO | VERSION | V0.1 | | | Shows installed software version | |
| | RDM | UID | 0x21A40067____ | | Displays Current UID # | |
| | | LABEL | COLORado 1 SoLo | | | Product Name |

Configuration (Standalone) Use standalone configuration to operate the product without a DMX controller.

Auto Programs Auto programs allow for dynamic RGBW color mixing without a DMX controller.

1. Go to the **AUTO PRPGRAM** main level.
2. Select the desired auto (**AUTO1-10**) and (**Speed 000-255**) or custom program (**PROGRAM1-10**).



You cannot edit any of the auto programs (AUTO1-10); however, you can edit the custom programs (PROGRAM1-10). See [Edit Custom Programs](#) for details.

Edit Custom Programs This setting allows the programming of up to 30 scenes for each of the 10 customizable programs, including colors and effects.

1. Go to the **EDIT** main level.
2. Select the desired auto program (**PROGRAM01-10**).
3. Select the desired scene (**SCENE 01-30**).
4. Select the desired color or effect (**RED, GREEN, BLUE, WHITE, STROBE, TIME, or FADE**).
5. Select the color or effect value (**000-255**).
6. Repeat for the other colors or effects.
7. Return to the scene (**SCENE 01-30**) level.
8. Repeat the settings of colors and effects for the other scenes.

Master/Slave The Master/Slave mode allows a group of COLORado 1 Solos (the slaves) to simultaneously duplicate the output of another COLORado 1 Solo (the master) without a DMX controller.

1. Set each of the slaves:
 - a. Go to the **RUN MODE** main level.
 - b. Select **SLAVE**.
2. Set the master:
 - a. Set the running mode to **DMX** as explained in [DMX Control](#).
 - b. Select an auto or custom program as explained in [Auto Programs](#), or a static mix of colors.



- **The master is the one that runs a program whether in Auto, Custom or Static Color mode.**
- **Do not connect a DMX controller to the products configured for Master/Slave operation. The DMX controller may interfere with signals from the master.**
- **The master should be the first product in the daisy chain.**

Dimmer Profiles This setting determines how fast the output of the COLORado 1 Solo changes when you modify the values of the red, green, blue, white, and dimmer faders. This setting provides four different options to simulate the dimming curve of an incandescent lighting product.

1. Go to the **SETTING** main level.
2. Enter the master access passcode as described in [Passcode](#).
3. Select **DIMMER**.
4. Select a dimmer curve (**OFF**, **DIM1**, **DIM2**, **DIM3**, or **DIM4**).



- OFF:** The output is proportional (linear) to the dimmer and RGBW channel values.
- DIM1–4:** The output follows the dimmer and RGBW channel values based on the corresponding dimmer curve, **DIM1** being the fastest and **DIM4** the slowest.



For optimum control of the 16-bit dimming channels in the TR16 and STD.Y personalities, be sure that both dimming curves in SETTING > DIMMER are set to OFF.



When the control panel lock is active, the product will prompt you to enter the passcode after 30 seconds of control panel inactivity or after turning on the product. See [Passcode](#).

Program Upload This option allows you to copy the custom programs of one COLORado 1 Solo onto other COLORado 1 Solo by using the Master/Slave mode.

1. Configure and connect the products in a Master/Slave arrangement, where the master has the custom programs you want to transfer to the slaves.
2. From the master, go to the **SETTING** main level.
3. Enter the master access passcode as shown in [Passcode](#).
4. Select **UPLOAD**.
5. Enter the master access passcode as shown in [Passcode](#).
6. When **SEND** shows, press **<ENTER>** to start the upload.
7. Wait for the upload process to finish (the display will show **END** before continuing or turning the products off).

The master and slaves will provide the status of the process by lighting up as follows:



- **Yellow** indicates that the upload process is running.
- **Green** indicates that the upload process completed successfully.
- **Red** indicates that the upload process failed due to an error. Recheck all cable connections and restart the process. If the issue persists, contact Chauvet Technical Support.



DO NOT upload the data from a COLORado 1 Solo to a different product. The other product may become inoperative.

Reset This setting allows you to reset the COLORado 1 Solo to the default values, including the custom programs.

1. Go to the **SETTING** main level.
2. Enter the master access passcode as described in [Passcode](#).
3. Select **RESET**.
4. Enter the master access passcode as described in [Passcode](#).
5. Wait for the reset process to finish.

- Whites Setting** This setting allows you to select and edit the temperature of the white colors used in channel 6 (Macros) when in the **TOUR** mode, channel 11 when in the **TR16** and **STD.Y** mode, or channel 5 when in the **HSIC** mode.
1. Go to the **CALIB.C** main level.
 2. Enter the master access passcode as described in [Passcode](#).
 3. Select a white color (**WHITE > WHITE 01-13**).
 4. Select a white color sides (**X FINE-Y Fine**).
 5. Select a white color side value (**+/- 200**).
 6. Repeat for the other colors.
- Static Color** The Static Color mode allows for permanent RGBW color mixing without a DMX controller.
1. Go to the **STATIC** main level.
 2. Select the desired color or effect (**RED, GREEN, BLUE, WHITE, STROBE, or ZOOM**).
 3. Select the color or effect value (**000–255** for colors, strobe, and effect).
 4. Repeat for the other colors or effects.
- Color Temperature Settings** This setting controls the color temperature with preset white output options when all color faders are set to 100%.
1. Go to the **SETTING** main level.
 2. Enter the master access passcode as described in [Passcode](#).
 3. Select **FULL POWER CCT**.
 4. Choose a white output color temperature. (**WARM WHITE, NEUTRAL WHITE, COOL WHITE#1, COOL WHITE#2, or NORMAL**)
- Zoom Mode** These settings are to be changed when operating in environmental temperatures lower than 40 °F. The default setting for normal operating temperatures above 40 °F is **ZOOM MODE 1**.
1. Go to the **ZOOM MODE** main level.
 2. Select **ZOOM MODE 1** for use in normal operating temperature environments or **ZOOM MODE 2** environmental temperatures lower than 40 °F.
- LED Frequency** This option changes the Pulse Width Modulation (PWM) frequency of the LEDs on the COLORado 1 Solo.
1. Go to the **SETTING** main level.
 2. Enter the master access passcode as described in [Passcode](#).
 3. Select **PWM**.
 4. Choose an output frequency. (**600Hz, 1200Hz, 2000Hz, 2400Hz, 6000Hz, 18000Hz, or 25000Hz**)
- Software Information** This option shows what version of software the COLORado 1 Solo is running.
1. Go to the **INFO** main level.
 2. Select **VERSION** and the version number will show on the screen.
- RDM** This option shows the product's **UID #** and the product name.
1. Go to the **RDM** main level.
 2. Select **UID** and the version number will show on the screen.
 3. Select **LABEL** and the product name will show on the screen.

Configuration (DMX)

Use DMX configurations to operate the product with a DMX controller.

DMX Personalities

This setting allows you to choose a particular DMX personality.

1. Go to the **PERSONALITY** main level.
2. Select the desired personality (**TOUR**, **TR16**, **STD.Y**, **HSIC**, or **SSP**).



- **See the DMX Values section for the highest starting address you can select for each personality.**
- **Make sure that the starting addresses on the various products do not overlap due to the new personality setting.**

DMX Control

In this mode, each product will respond to a unique starting address from the DMX controller. All products with the same starting address will respond in unison.

1. Select a DMX personality as shown in [DMX Personalities](#).
2. Set the running mode:
 - a. Go to the **RUN MODE** main level.
 - b. Select the **DMX** programming level.
3. Set the starting address:
 - a. Go to **ADDRESS** main level.
 - b. Select the starting address (**001–512**).

The highest recommended starting address for each DMX mode is as follows:



| DMX Personality | DMX Address | DMX Personality | DMX Address | DMX Personality | DMX Address |
|-----------------|-------------|-----------------|-------------|-----------------|-------------|
| TOUR | 501 | TR16 | 496 | STD.Y | 496 |
| HSIC | 504 | SSP | 504 | | |

Loss Of Signal Setting

This setting controls how the product will respond when the DMX signal is lost.

1. Go to the **SETTING** main level.
2. Enter the master access passcode as described in [Passcode](#).
3. Select **DMX ERROR**.
 - a. Select **SAVE** to make the product use the last command used when the signal is lost.
 - b. Select **BLACK** to turn off the all the LEDs when the signal is lost.

TOUR Notes These notes clarify the way the **TOUR** DMX personality works.

- Master Dimmer**
 - Channel 1 controls the intensity of the currently projected color.
 - When the slider is at the highest position (**100%**), the intensity of the output is at maximum.
- Red, Green, Blue, and White Color Selection**
 - Channels 2 through 5 control the intensity ratio of each of the red, green, blue, and white LEDs.
 - When these channels are at the highest position (**100%**), the intensity of each color is at maximum if **SETTING > COLOR** is **OFF**.
 - You can combine channels 2 through 5 to create over one trillion colors.
- Color Macros**
 - Channel 6 selects the required color macro.
 - Channel 6 has priority over channels 2 through 6.
 - Channel 1 controls the intensity of the color macro.
- Strobe**
 - Channel 7 controls the strobe frequency (not the intensity) of channels 2 through 6.
 - Channel 7 can strobe channels 2 through 5 when not running macros, allowing the individual faders (**R**, **G**, **B**, and **W**), as well as channel 1 (**D**), to control the output intensity.
 - Channel 7 can strobe channel 6 when running macros, allowing channel 6 to select the macro and channel 1 to control the output intensity.
- Auto/Custom**
 - Channel 8 selects the preset auto programs **AUTO01–10** or the custom programs **PROGRAM1-10**.
 - When activating the custom auto programs **PROGRAM1-10**, you can control the step time and fade time using channels 2 and 3, respectively.
 - Channel 8 has priority over channels 2 through 7.
 - Channel 9 controls the speed at which each auto program plays.
- Zoom**
 - Channel 10 controls Zoom adjustment. This provides options to adjust the beam angle from 8 to 55 degrees.
 - Channel 11 resets the zoom lens to the home position.
- Dimmer Speed**
 - Channel 12 selects the Dimmer mode and speed. Dimmer mode provides four different options to simulate the dimming curve of an incandescent lighting product.
 - When dimmer is set to **OFF**, the changes in the RGBW and master dimmer faders are linear.
 - When dimmer is set to **DIM1–DIM4**, **DIM1** is the fastest dimmer curve and **DIM4** is the slowest.

DMX Values

STD.Y

| Channel | Function | Value | Percent/Setting |
|----------|---------------|----------|--|
| 1 | Dimmer | 000ó 255 | 0–100% |
| 2 | Dimmer Fine | 000ó 255 | Fine control (16-bit) (Step Duration if Custom 1–10 in CH. 13 is active) |
| 3 | Red | 000ó 255 | 0–100% (Fade Duration if Custom 1–10 in CH. 13 is active) |
| 4 | Red Fine | 000ó 255 | Fine control (16-bit) |
| 5 | Green | 000ó 255 | 0–100% |
| 6 | Green Fine | 000ó 255 | Fine control (16-bit) |
| 7 | Blue | 000ó 255 | 0–100% |
| 8 | Blue Fine | 000ó 255 | Fine control (16-bit) |
| 9 | White | 000ó 255 | 0–100% |
| 10 | White Fine | 000ó 255 | Fine control (16-bit) |
| 11 | Color Macro | 000ó 010 | No function |
| | | 011ó 030 | R: 100% G: 0-100% B: 0 |
| | | 031ó 050 | R: 100%-0 G: 100% B: 0 |
| | | 051ó 070 | R: 0 G: 100% B: 0-100% |
| | | 071ó 090 | R: 0 G: 100%-0 B: 100% |
| | | 091ó 110 | R: 0-100% G: 0 B: 100% |
| | | 111ó 130 | R: 100% G: 0 B: 100%-0 |
| | | 131ó 150 | R: 100% G: 0-100% B: 0-100% |
| | | 151ó 170 | R: 100%-0 G: 100%-0 B: 100% |
| | | 171ó 195 | R: 100% G: 100% B: 100% W: 100% |
| | | 196ó 200 | White 1 |
| | | 201ó 205 | White 2 |
| | | 206ó 210 | White 3 |
| | | 211ó 215 | White 4 |
| | | 216ó 220 | White 5 |
| | | 221ó 225 | White 6 |
| 226ó 230 | White 7 | | |
| 231ó 235 | White 8 | | |
| 236ó 240 | White 9 | | |
| 241ó 245 | White 10 | | |
| 246ó 250 | White 11 | | |
| 251ó 255 | White 12 | | |
| 12 | Strobe Effect | 000ó 009 | No function |
| | | 010ó 099 | 0–25 Hz |
| | | 100ó 109 | No function |
| | | 110ó 179 | Lightning Strobe |
| | | 180ó 189 | No function |
| | | 190ó 255 | Random Strobe |

DMX Values (Cont.)

| STD.Y (Cont.) | Channel | Function | Value | Percent/Setting |
|------------------|---------------------|-----------------|-----------|--|
| | 13 | Programs | 000 ó 040 | No function |
| | | | 041 ó 050 | Auto 1 |
| | | | 051 ó 060 | Auto 2 |
| | | | 061 ó 070 | Auto 3 |
| | | | 071 ó 080 | Auto 4 |
| | | | 081 ó 090 | Auto 5 |
| | | | 091 ó 100 | Auto 6 |
| | | | 101 ó 110 | Auto 7 |
| | | | 111 ó 120 | Auto 8 |
| | | | 121 ó 130 | Auto 9 |
| | | | 131 ó 140 | Auto 10 |
| | | | 141 ó 150 | Custom 1 |
| | | | 151 ó 160 | Custom 2 |
| | | | 161 ó 170 | Custom 3 |
| | | | 171 ó 180 | Custom 4 |
| | | | 181 ó 190 | Custom 5 |
| | 191 ó 200 | Custom 6 | | |
| | 201 ó 210 | Custom 7 | | |
| | 211 ó 220 | Custom 8 | | |
| | 221 ó 230 | Custom 9 | | |
| | 231 ó 255 | Custom 10 | | |
| 14 | Auto Speed | | 000 ó 255 | 0–100% (Only when using Auto 1–10) |
| 15 | Zoom | | 000 ó 255 | 0–100% |
| 16 | Zoom Control | | 000 ó 200 | No function |
| | | | 201 ó 220 | Zoom reset |
| | | | 221 ó 255 | No function |
| 17 | Dimmer Speed | | 000 ó 009 | Preset dimmer speed from display menu |
| | | | 010 ó 029 | Linear dimmer |
| | | | 030 ó 069 | Nonlinear dimming curve 1 (fastest) |
| | | | 070 ó 129 | Nonlinear dimming curve 2 |
| | | | 130 ó 189 | Nonlinear dimming curve 3 |
| | | | 190 ó 255 | Nonlinear dimming curve 4 (slowest) |

DMX Values (Cont.)

| TR16 | Channel | Function | Value | Percent/Setting |
|------|----------|---------------|----------|--|
| | 1 | Dimmer | 000ó 255 | 0–100% |
| | 2 | Dimmer Fine | 000ó 255 | Fine control (16-bit) (Step Duration if Custom 1–10 in CH. 13 is active) |
| | 3 | Red | 000ó 255 | 0–100% (Fade Duration if Custom 1–10 in CH. 13 is active) |
| | 4 | Red Fine | 000ó 255 | Fine control (16-bit) |
| | 5 | Green | 000ó 255 | 0–100% |
| | 6 | Green Fine | 000ó 255 | Fine control (16-bit) |
| | 7 | Blue | 000ó 255 | 0–100% |
| | 8 | Blue Fine | 000ó 255 | Fine control (16-bit) |
| | 9 | White | 000ó 255 | 0–100% |
| | 10 | White Fine | 000ó 255 | Fine control (16-bit) |
| | 11 | Color Macro | 000ó 010 | No function |
| | | | 011ó 030 | R: 100% G: 0-100% B: 0 |
| | | | 031ó 050 | R: 100%-0 G: 100% B: 0 |
| | | | 051ó 070 | R: 0 G: 100% B: 0-100% |
| | | | 071ó 090 | R: 0 G: 100%-0 B: 100% |
| | | | 091ó 110 | R: 0-100% G: 0 B: 100% |
| | | | 111ó 130 | R: 100% G: 0 B: 100%-0 |
| | | | 131ó 150 | R: 100% G: 0-100% B: 0-100% |
| | | | 151ó 170 | R: 100%-0 G: 100%-0 B: 100% |
| | | | 171ó 195 | R: 100% G: 100% B: 100% W: 100% |
| | | | 196ó 200 | White 1 |
| | | | 201ó 205 | White 2 |
| | | | 206ó 210 | White 3 |
| | | | 211ó 215 | White 4 |
| | | | 216ó 220 | White 5 |
| | 221ó 225 | White 6 | | |
| | 226ó 230 | White 7 | | |
| | 231ó 235 | White 8 | | |
| | 236ó 240 | White 9 | | |
| | 241ó 245 | White 10 | | |
| | 246ó 250 | White 11 | | |
| | 251ó 255 | White 12 | | |
| | 12 | Strobe Effect | 000ó 009 | No function |
| | | | 010ó 099 | 0–25 Hz |
| | | | 100ó 109 | No function |
| | | | 110ó 179 | Lightning Strobe |
| | | | 180ó 189 | No function |
| | | | 190ó 255 | Random Strobe |

DMX Values (Cont.)

| TR16 (Cont.) | Channel | Function | Value | Percent/Setting |
|-----------------|--------------|-------------------------------------|-----------|--|
| 13 | Programs | | 000 ó 040 | No function |
| | | | 041 ó 050 | Auto 1 |
| | | | 051 ó 060 | Auto 2 |
| | | | 061 ó 070 | Auto 3 |
| | | | 071 ó 080 | Auto 4 |
| | | | 081 ó 090 | Auto 5 |
| | | | 091 ó 100 | Auto 6 |
| | | | 101 ó 110 | Auto 7 |
| | | | 111 ó 120 | Auto 8 |
| | | | 121 ó 130 | Auto 9 |
| | | | 131 ó 140 | Auto 10 |
| | | | 141 ó 150 | Custom 1 |
| | | | 151 ó 160 | Custom 2 |
| | | | 161 ó 170 | Custom 3 |
| | | | 171 ó 180 | Custom 4 |
| | 181 ó 190 | Custom 5 | | |
| | 191 ó 200 | Custom 6 | | |
| | 201 ó 210 | Custom 7 | | |
| | 211 ó 220 | Custom 8 | | |
| | 221 ó 230 | Custom 9 | | |
| | 231 ó 255 | Custom 10 | | |
| 14 | Auto Speed | | 000 ó 255 | 0–100% (Only when using Auto 1–10) |
| 15 | Zoom | | 000 ó 255 | 0–100% |
| 16 | Zoom Control | | 000 ó 200 | No function |
| | | | 201 ó 220 | Zoom reset |
| | | | 221 ó 255 | No function |
| 17 | Dimmer Speed | | 000 ó 009 | Preset dimmer speed from display menu |
| | | | 010 ó 029 | Linear dimmer |
| | | | 030 ó 069 | Nonlinear dimming curve 1 (fastest) |
| | | | 070 ó 129 | Nonlinear dimming curve 2 |
| | | | 130 ó 189 | Nonlinear dimming curve 3 |
| | 190 ó 255 | Nonlinear dimming curve 4 (slowest) | | |

DMX Values (Cont.)

| TOUR | Channel | Function | Value | Percent/Setting |
|------|-----------|---------------|-----------|---|
| | 1 | Dimmer | 000 ∘ 255 | 0–100% |
| | 2 | Red | 000 ∘ 255 | Fine control (16-bit) (Step Duration if Custom 1–10 in CH. 8 is active) |
| | 3 | Green | 000 ∘ 255 | 0–100% (Fade Duration if Custom 1–10 in CH. 8 is active) |
| | 4 | Blue | 000 ∘ 255 | 0–100% |
| | 5 | White | 000 ∘ 255 | 0–100% |
| | 6 | Color Macro | 000 ∘ 010 | No function |
| | | | 011 ∘ 030 | R: 100% G: 0-100% B: 0 |
| | | | 031 ∘ 050 | R: 100%-0 G: 100% B: 0 |
| | | | 051 ∘ 070 | R: 0 G: 100% B: 0-100% |
| | | | 071 ∘ 090 | R: 0 G: 100%-0 B: 100% |
| | | | 091 ∘ 110 | R: 0-100% G: 0 B: 100% |
| | | | 111 ∘ 130 | R: 100% G: 0 B: 100%-0 |
| | | | 131 ∘ 150 | R: 100% G: 0-100% B: 0-100% |
| | | | 151 ∘ 170 | R: 100%-0 G: 100%-0 B: 100% |
| | | | 171 ∘ 195 | R: 100% G: 100% B: 100% W: 100% |
| | | | 196 ∘ 200 | White 1 |
| | | | 201 ∘ 205 | White 2 |
| | | | 206 ∘ 210 | White 3 |
| | | | 211 ∘ 215 | White 4 |
| | | | 216 ∘ 220 | White 5 |
| | | | 221 ∘ 225 | White 6 |
| | 226 ∘ 230 | White 7 | | |
| | 231 ∘ 235 | White 8 | | |
| | 236 ∘ 240 | White 9 | | |
| | 241 ∘ 245 | White 10 | | |
| | 246 ∘ 250 | White 11 | | |
| | 251 ∘ 255 | White 12 | | |
| | 7 | Strobe Effect | 000 ∘ 009 | No function |
| | | | 010 ∘ 099 | 0–25 Hz |
| | | | 100 ∘ 109 | No function |
| | | | 110 ∘ 179 | Lightning Strobe |
| | | | 180 ∘ 189 | No function |
| | | | 190 ∘ 255 | Random Strobe |

DMX Values (Cont.)

| TOUR (Cont.) | Channel | Function | Value | Percent/Setting |
|-----------------|---------------------|-------------------------------------|-----------|--|
| | 8 | Programs | 000 ó 040 | No function |
| | | | 041 ó 050 | Auto 1 |
| | | | 051 ó 060 | Auto 2 |
| | | | 061 ó 070 | Auto 3 |
| | | | 071 ó 080 | Auto 4 |
| | | | 081 ó 090 | Auto 5 |
| | | | 091 ó 100 | Auto 6 |
| | | | 101 ó 110 | Auto 7 |
| | | | 111 ó 120 | Auto 8 |
| | | | 121 ó 130 | Auto 9 |
| | | | 131 ó 140 | Auto 10 |
| | | | 141 ó 150 | Custom 1 |
| | | | 151 ó 160 | Custom 2 |
| | | | 161 ó 170 | Custom 3 |
| | | | 171 ó 180 | Custom 4 |
| | | | 181 ó 190 | Custom 5 |
| | 191 ó 200 | Custom 6 | | |
| | 201 ó 210 | Custom 7 | | |
| | 211 ó 220 | Custom 8 | | |
| | 221 ó 230 | Custom 9 | | |
| | 231 ó 255 | Custom 10 | | |
| 9 | Auto Speed | | 000 ó 255 | 0–100% (Only when using Auto 1–10) |
| 10 | Zoom | | 000 ó 255 | 0–100% |
| 11 | Zoom Control | | 000 ó 200 | No function |
| | | | 201 ó 220 | Zoom reset |
| | | | 221 ó 255 | No function |
| 12 | Dimmer Speed | | 000 ó 009 | Preset dimmer speed from display menu |
| | | | 010 ó 029 | Linear dimmer |
| | | | 030 ó 069 | Nonlinear dimming curve 1 (fastest) |
| | | | 070 ó 129 | Nonlinear dimming curve 2 |
| | | | 130 ó 189 | Nonlinear dimming curve 3 |
| | 190 ó 255 | Nonlinear dimming curve 4 (slowest) | | |

DMX Values (Cont.)

| SSP | Channel | Function | Value | Percent/Setting |
|-----|---------|----------------------|-------------------------------------|---------------------------------------|
| | 1 | Dimmer | 000 ó 255 | 0–100% |
| | 2 | Red | 000 ó 255 | 0–100% |
| | 3 | Green | 000 ó 255 | 0–100% |
| | 4 | Blue | 000 ó 255 | 0–100% |
| | 5 | White | 000 ó 255 | 0–100% |
| | 6 | Strobe Effect | 000 ó 009 | No function |
| | | | 010 ó 099 | 0–25 Hz |
| | | | 100 ó 109 | No function |
| | | | 110 ó 179 | Lightning Strobe |
| | | | 180 ó 189 | No function |
| | | | 190 ó 255 | Random Strobe |
| | 7 | Zoom | 000 ó 255 | 0–100% |
| | 8 | Zoom Control | 000 ó 200 | No function |
| | | | 201 ó 220 | Zoom reset |
| | | | 221 ó 255 | No function |
| | 9 | Dimmer Speed | 000 ó 009 | Preset dimmer speed from display menu |
| | | | 010 ó 029 | Linear dimmer |
| | | | 030 ó 069 | Nonlinear dimming curve 1 (fastest) |
| | | | 070 ó 129 | Nonlinear dimming curve 2 |
| | | | 130 ó 189 | Nonlinear dimming curve 3 |
| | | 190 ó 255 | Nonlinear dimming curve 4 (slowest) | |

DMX Values (Cont.)

| HSIC | Channel | Function | Value | Percent/Setting |
|------|----------|-------------------------------------|----------|---------------------------------------|
| | 1 | Dimmer | 000ó 255 | 0–100% |
| | 2 | Hue | 000ó 255 | 0–100% |
| | 3 | Hue Fine | 000ó 255 | 0–100% |
| | 4 | Saturation | 000ó 255 | 0–100% |
| | 5 | Color Macro | 000ó 010 | No function |
| | | | 011ó 030 | White 1 |
| | | | 031ó 050 | White 2 |
| | | | 051ó 070 | White 3 |
| | | | 071ó 090 | White 4 |
| | | | 091ó 110 | White 5 |
| | | | 111ó 130 | White 6 |
| | | | 131ó 150 | White 7 |
| | | | 151ó 170 | White 8 |
| | | | 171ó 190 | White 9 |
| | | | 191ó 210 | White 10 |
| | | | 211ó 230 | White 11 |
| | 231ó 255 | White 12 | | |
| | 6 | Strobe Effect | 000ó 009 | No function |
| | | | 010ó 099 | 0–25 Hz |
| | | | 100ó 109 | No function |
| | | | 110ó 179 | Lightning Strobe |
| | | | 180ó 189 | No function |
| | 190ó 255 | Random Strobe | | |
| | 7 | Zoom | 000ó 255 | 0–100% |
| | 8 | Zoom Control | 000ó 200 | No function |
| | | | 201ó 220 | Zoom reset |
| | | | 221ó 255 | No function |
| | 9 | Dimmer Speed | 000ó 009 | Preset dimmer speed from display menu |
| | | | 010ó 029 | Linear dimmer |
| | | | 030ó 069 | Nonlinear dimming curve 1 (fastest) |
| | | | 070ó 129 | Nonlinear dimming curve 2 |
| | | | 130ó 189 | Nonlinear dimming curve 3 |
| | 190ó 255 | Nonlinear dimming curve 4 (slowest) | | |

5. Technical Information

Product Maintenance

To maintain optimum performance and minimize wear, clean this product frequently. Usage and environment are contributing factors in determining the cleaning frequency.

As a rule, clean this product at least twice a month. Dust build-up reduces light output performance and can cause overheating. This can lead to reduced light source life and increased mechanical wear.

To clean your product:

1. Unplug the product from power.
2. Wait until the product is at room temperature.
3. Use a vacuum (or dry compressed air) and a soft brush to remove dust collected on the external vents.
4. Clean all external surfaces with a mild solution of non-ammonia glass cleaner or isopropyl alcohol.
5. Apply the solution directly to a soft, lint-free cotton cloth or a lens cleaning tissue.
6. Wipe any dirt or grime to the outside edges of the lens surface.
7. Gently polish the lens surfaces until they are free of haze and lint.



Always dry the external surfaces thoroughly and carefully after cleaning them.

6. Technical Specifications

| | | | | |
|---|----------------------------------|-------------------------|------------------|--------------------------|
| Dimensions and Weight | Length | Width | Height | Weight |
| | 13.62 in (346 mm) | 6.93 in (176 mm) | 9.53 in (242 mm) | 11.8 lb (5.4 kg) |
| Note: Dimensions in inches rounded to the nearest decimal digit. | | | | |
| Power | Power Supply Type | Range | | Voltage Selection |
| | Switching (internal) | 100–240 VAC, 50/60 Hz | | Auto-ranging |
| | Parameter | 120 VAC, 60 Hz | | 230 VAC, 50 Hz |
| | Consumption | 65 W | | 65 W |
| | Current | 0.548 A | | 0.297 A |
| | Power linking current (products) | 13.6 A (24 products) | | 8 A (45 products) |
| | Power I/O | U.S./Canada | | Worldwide |
| | Power input connector | Seetronic Powerkon IP65 | | Seetronic Powerkon IP65 |
| | Power output connector | Seetronic Powerkon IP65 | | Seetronic Powerkon IP65 |
| | Power cord plug | Edison (U.S.) | | Local plug |
| Light Source | Type | Power | | Lifespan |
| | LED | 60 W | | 50,000 hours |
| | Color | Quantity | | Current |
| | quad-color RGBW | 1 | | 4 A |
| Photometrics | Parameter | Narrow Zoom | | Wide Zoom |
| | Illuminance @ 5 m | 5,370 lux | | 97 lux |
| | Beam angle | 4° | | 40° |
| | Field angle | 8° | | 55° |
| Thermal | Max. External Temperature | Cooling System | | |
| | 113 °F (45 °C) | Convection | | |
| DMX | I/O Connectors | Connector Type | | Channel Range |
| | Seetronic IP65 5-pin XLR | Sockets | | 9, 12 or 17 |
| Ordering | Product Name | Item Code | | UPC Number |
| | COLORado 1 Solo | 01031124 | | 781462214722 |



UL 1573
CSA C22.2 No. 166
E113093



Returns Send the product prepaid, in the original box, and with the original packing and accessories. Chauvet will not issue call tags.
 Call Chauvet and request a Return Merchandise Authorization (RMA) number before shipping the product. Be prepared to provide the model number, serial number, and a brief description of the cause(s) for the return.
 Clearly label the package with an RMA number. Chauvet will refuse any product returned without an RMA number.



DO NOT write the RMA number directly on the box. Instead, write it on a properly affixed label.

Once you have received the RMA number, include the following information on a piece of paper inside the box:

- Your name
- Your address
- Your phone number
- The RMA number
- A brief description of the problem(s)

Be sure to pack the product properly. Any shipping damage resulting from inadequate packaging will be the customer's responsibility. FedEx packing or double-boxing is recommended.



Chauvet reserves the right to use its own discretion to repair or replace returned product(s).

Contact Us

| General Information | Technical Support |
|---|---|
| Chauvet World Headquarters | |
| Address: 5200 NW 108th Avenue Sunrise, FL 33351 Voice: (954) 577-4455 Toll free: (800) 762-1084 | Voice: (844) 393-7575 Email: chauvetcs@chauvetlighting.com Website: www.chauvetprofessional.com |
| Chauvet Europe Ltd | |
| Address: Unit 1C Brookhill Road Industrial Estate Pinxton, Nottingham, UK NG16 6NT Voice: +44 (0)1773 511115 | Email: uktech@chauvetlighting.com Website: www.chauvetlighting.co.uk |
| Chauvet Europe BVBA | |
| Address: Stokstraat 18 9770 Kruishoutem Belgium Voice: +32 9 388 93 97 | Email: Eutech@chauvetlighting.com Website: www.chauvetlighting.eu |
| Chauvet France | |
| Address: 3, Rue Ampère 91380 Chilly-Mazarin France Voice: +33 1 78 85 33 59 | Email: Eutech@chauvetlighting.com Website: www.chauvetlighting.eu |
| Chauvet Germany | |
| Address: Bruno-Bürgel-Str. 11 28759 Bremen Germany Voice: +49 421 62 60 20 | Email: Eutech@chauvetlighting.com Website: www.chauvetlighting.eu |
| Chauvet Mexico | |
| Address: Av. de las Partidas 34-3B (Entrance by Calle 2) Zona Industrial Lerma Lerma, Mexico C.P. 52000 Voice: +52 (728) 690-2010 | Email: servicio@chauvet.com.mx Website: www.chauvetprofessional.mx |

Outside the U.S., U.K., Ireland, Benelux, France, Germany, or Mexico, contact the dealer of record. Follow the instructions to request support or to return a product. Visit our website for contact details