

JBL

Control[®] 60PS/T

Pendant Subwoofer with Crossover

Professional Series

Key Features:

- ▶ High impact, 150 Watt direct radiating pendant subwoofer with built-in passive crossover for up to four satellite speakers.
- ▶ 200 mm (8 in) long-excursion driver.
- ▶ 8 ohm (150 Watt) and 70V/100V (100 Watt) operation.
- ▶ Hanging hardware with 4.5 m (15 foot) galvanized steel cable and easy to adjust clamp.
- ▶ Stylish design, available in black or white (-WH).
- ▶ UL listed (speaker and hanging cable system).

Applications:

The Control 60PS/T pendant subwoofer loudspeaker provides bass extension and high impact for high-fidelity sound systems in a wide variety of applications including restaurants, retail stores, music cafes, health clubs, theme bars, leisure venues, and other locations where full-range high fidelity foreground/background music systems are utilized. Featuring 150 Watt power handling and low distortion, the long-excursion 200 mm (8 in) low frequency driver features butyl rubber surround for well-damped, tight sound quality and long-term reliability, and a polypropylene-coated cone for humidity protection. The high-temperature 50 mm (2 in) voice coil and low-mass fiberglass coil former ensure good bass transient response and excellent stability under high power, high duty-cycle, working conditions.

The Control 60PS/T may be driven by itself (or with other subwoofers) on an amplifier channel, sending it either a signal that has been actively low-passed earlier in the signal chain via DSP or a full-range signal, utilizing the built-in passive 125 Hz low-pass filter. The included passive crossover also provides high-passed satellite outputs for use with either two or four satellite loudspeakers (not for one or three satellite speakers), resulting in a full-range, wide-bandwidth, passively-crossed, mono subwoofer-satellite system. Using the built-in passive crossover is best suited for satellite speakers with sensitivities in the 82 dB to 86 dB (2.83V @ 1m) range, resulting in a well-balanced overall frequency response.

A 100 Watt multi-tap, wide-bandwidth, low-saturation transformer allows the speaker to be used on either a 70V/100V distributed speaker system or as a direct low-impedance 8Ω speaker. If satellite speakers are used on the 70V/100V settings, the satellite speakers should be low-impedance (8Ω to 16Ω each).

A loop out connector is provided on the subwoofer for looping the full-range input signal to other loudspeakers or to other subwoofer/satellite systems. Rubber boot covers for each locking connector protect the terminals and the optional MTC-PC60 full-top cover accessory adds additional terminal protection for when using outdoors.

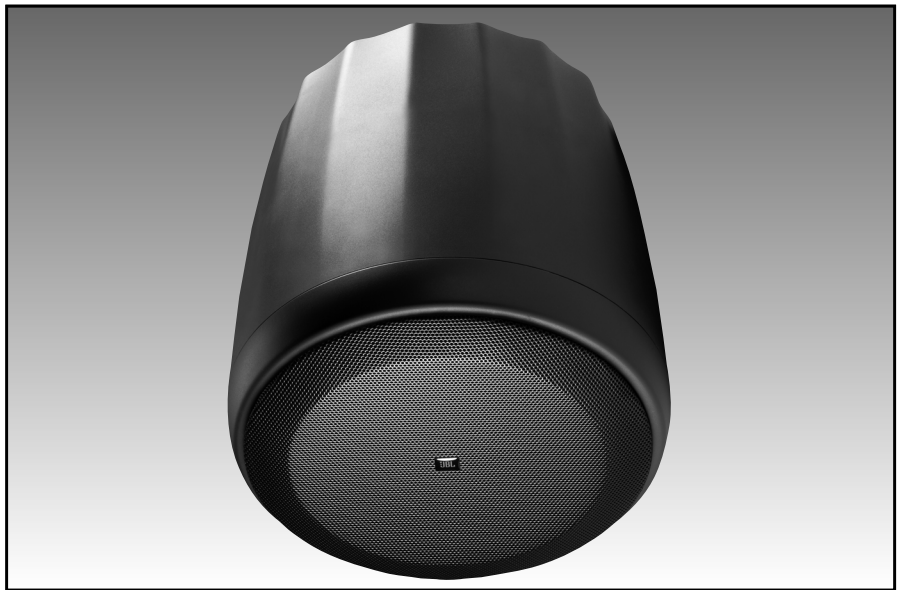

Specifications:

| | |
|---------------------------------|---|
| System: | |
| Frequency Range (-10 dB): | 42 Hz – 350 Hz |
| Frequency Response (± 3 dB): | 55 Hz – 125 Hz |
| Power Capacity: | 300 Watts Continuous Program Power, 100 hrs 150 Watts Continuous Pink Noise, 100 hrs |
| Nominal Sensitivity (2.83V/1m): | 88 dB |
| Rated Maximum SPL: | 107 dB @ 1 m (3.3 ft) average, 113 dB peak |
| Rated Impedance: | 8 ohms |
| Transformer Taps: | 110W, 55W, 30W (& 15W@70V). Set via rotary tap-selector switch (70V/100V taps along with direct 8Ω setting) on top terminal panel |
| Transformer Insertion Loss: | 0.98 dB @ 15W, 0.99 dB @ 30W, 0.94 dB @ 55W, 1.10 @ 110W |
| Standalone Hookup: | Connect to Input connector; built-in low-pass filter permanently engaged. Loop Out in parallel with Input connector (pre low-pass filter) for sending to additional speakers. |
| Subwoofer-Satellite Hookup: | For either two or four satellite speakers (not for one or three satellite speakers). With two satellite speakers, must connect to Sat 1 and Sat 2 terminals only (NC to Sat 3 and Sat 4 terminals). Satellite outputs high-passed. Suggested satellite speakers include Control 62P (pendant), Control 52 (surface-mount on-wall) and Control 42C (in-ceiling). Satellite speakers to be low-Z type (8 to 16Ω) regardless whether tap selector is set to low-Z or 70V/100V. Loop Out in parallel with Input connector (pre low-pass filter) for sending to additional speakers. |
| Transducer: | 200mm (8 in) polypropylene-coated paper cone with butyl rubber surround, 50 mm (2 in) high-temperature copper voice coil, vented fiberglass resin voice coil former. |
| Enclosure: | |
| Enclosure Material: | High impact polystyrene |
| Grille: | Zinc-plated steel grille with powder-coat finish, foam backing (grille and grille backing are removable for painting) |
| Environmental: | Exceeds Mil Spec 810 for humidity, salt spray, temperature & UV. IP44 capability per IEC 529 – splash-proof rating |
| Termination: | Six removable locking 2-pin connectors with screw-down terminals. Input, Loop Out, Sat 1, Sat 2, Sat 3, Sat 4. Max wire 12 AWG (2.5 mm ²). Rubber terminal covers included. |
| Suspension: | Two identical suspension cable systems (one as main suspension cable and the other as safety cable), each consisting of 4.5 m (15 ft) long, 2 mm (0.077 in) high-tensile galvanized-steel wire rope suspension cable with spring-clips for clipping onto the loudspeaker bracket and Gripple [™] brand adjustable-height cable fasteners for infinitely adjustable height. Cable has SWL rating of 45 kg (99 lb). |
| Safety Agency: | Speaker listed per UL1480 (UEAY), transformer registered per UL1876. In accordance with IEC60849/EN60849. Suspension system and Gripple [®] -brand cable fastener listed per UL1598 and UL2239, TUV, and CSA Class 3426-01 & Class 3426-81. |
| Dimensions: | 333 mm (13.1 in) diameter, 344 mm (13.6 in) height to top of cabinet. 369 mm (14.5 in) to top of suspension bracket. |
| Net Weight: | 7.6 kg (16.7 lb) |
| Shipping Weight: | 17.6 kg (38.7 lbs) per pair-packed carton |
| Included Accessories: | Two suspension cable systems (see “suspension”, above), six removable locking 2-pin euro-block connectors, six rubber cover boots for euro-block connectors. |
| Optional Accessories: | MTC-PC60 full top panel / terminal cover. Wire access holes in plastic cover to be drilled by installer to suit the number and dimensions of wire. |
| Colors: | Available in black or white (-WH). Paintable. |

¹ Full-space (suspended)

² Continuous Pink Noise rating is IEC-shaped pink noise with a 6 dB crest factor for 100 hours continuously. Continuous Program power is conservative expression of the system's ability to handle normal speech and music program material, and is defined as 3 dB above the Continuous Pink Noise Rating.

JBL continually engages in research related to product improvement. Changes introduced into existing products without notice are an expression of that philosophy.

► Control 60PS/T 8" Pendant Sub-Woofer with Crossover

Frequency Response:

Full Space (4π), suspended

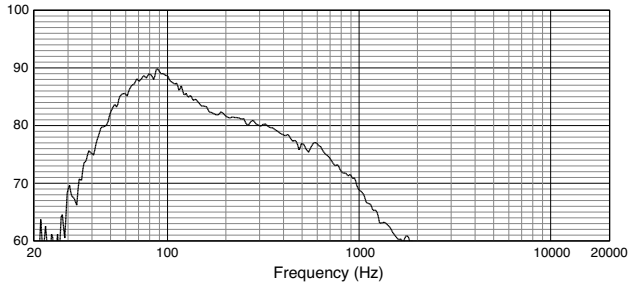

Impedance:

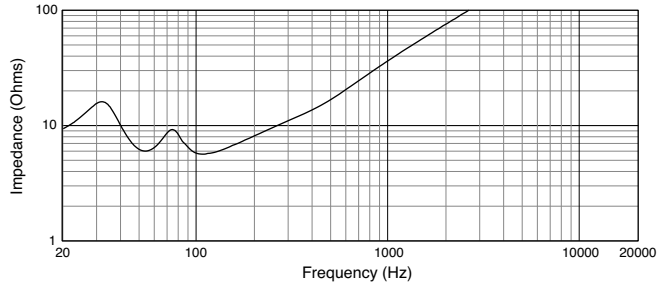

Dimensions:

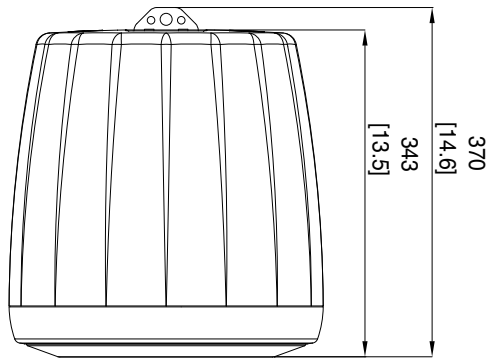
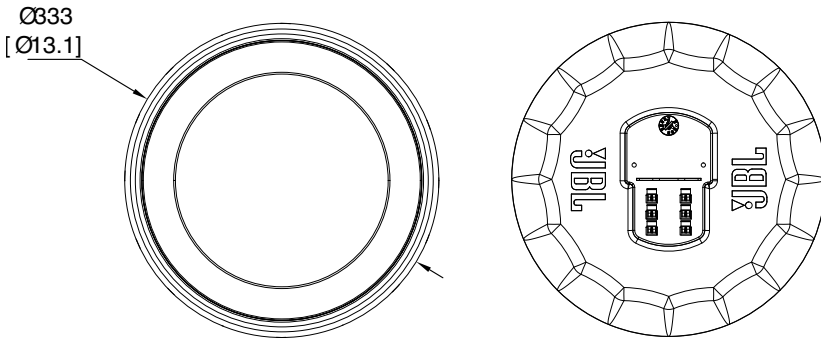

Dimensions in mm (in)

Using 2 Control 62P Satellite Loudspeakers

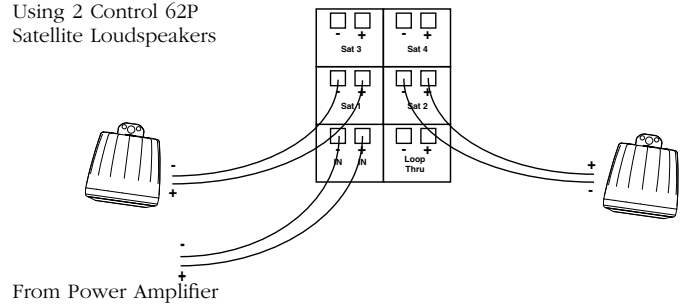

Using Four Control 62P Satellite Loudspeakers

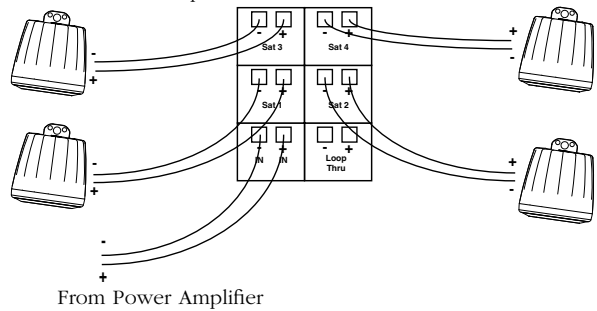

JBL Professional
8500 Balboa Boulevard, P.O. Box 2200
Northridge, California 91329 U.S.A.

© Copyright 2014 JBL Professional
www.jblpro.com

SS C60PST
CRP
05/14