



DIGITAL MIXING CONSOLE **M7CL**





Easy Digital At Last

Digital mixing consoles are certainly not new, but the evolution toward a truly intuitive, easy-to-use interface has been long and at times fraught with growing pains. If you've been delaying a move to digital because of interface or operational issues, the wait is over. The Yamaha M7CL Digital Mixing Console offers professional digital console performance and features for live sound in a 32- or 48-channel system that can actually be easier to use than a conventional analog console. It sounds great, too.



Centrallogic™ Brings It All Together

Yamaha's Centrallogic™ interface takes the most direct approach to giving you maximum operational ease and efficiency in a digital console. Rather than trying to simulate the feel and workflow of an analog mixer, Centrallogic™ goes straight to the heart of the matter, simplifying digital operation to the point where it is actually as intuitive as analog ... if not easier. A touch-panel display combined with Yamaha's acclaimed selected channel concept and a straightforward navigation system – no layers, one-function physical controls, and all digital controls can be accessed through just two main display screens – lets you focus in on any operation directly and instantly. In fact, the entire 32-channel or 48-channel console can quite easily be operated from the 44.2-centimeter-wide (that's a little over 17 inches) Centrallogic™ section alone.



Two Approaches to Total Access

Adjusting M7CL input and output levels is easy since individual 100-millimeter motor faders are provided for each channel. You have two ways to access the other mix controls – via the Selected Channel display or the Overview display. In fact, you can access the entire console via just these two displays – no need to flip through endless pages and menus to find the function you need. Here’s how ...



Overview

The Overview display – the console’s default display – gives you a standard view of the 8 channels selected via the Centralogic™ navigation keys. These keys, arranged in an exact replica of the 8-channel channel groups on the console, let you instantly bring any group of 8 channels to the central controls with a single button-press. You can then touch any row of controls on the display screen to focus on them – pan, or bus send, for example – and adjust via the corresponding multi-function encoders immediately below the display. It really is that simple, and armed with the information you have read in this brochure so far you should be able to perform a basic mix on the M7CL without even having to open the manual.



Overview



Selected Channel

Selected Channel

To adjust pan for a channel, for example, simply press the channel’s [SEL] key and rotate the console’s physical PAN control. The same applies to preamp gain, dynamics, high-pass filter, EQ, and bus send control. Adjustments are clearly shown on the display as you make them, and if you press any of the Selected Channel encoders the Selected Channel display will appear, showing you the current status of all mix parameters for the currently selected channel. You can also zoom in on any of the on-screen parameters for in-depth control by simply touching the parameter on the screen. When you’re focused on an individual parameter the multi-function encoders below the display screen adjust the corresponding parameters in the display.

Virtual Effect and GEQ Rack

Effects and graphic equalization are indispensable for most live sound applications, and having them built in is one of the many attractive features that only digital consoles can provide. The problem, sometimes, is finding them. Not so in the M7CL: just touch the RACK button on the display and the virtual effect and EQ rack pops right up for instant, easy access. A few quick touches on the screen and you can easily patch effects or graphic EQ into any channel and output. Another touch or two and you can get right inside the effects for detailed editing. The M7CL lets you use up to 8 signal processors simultaneously – normally that’s up to 4 effects and 4 graphic EQ units. But since the effect units can also function as graphic EQs, you can use more EQ units if you don’t need all 4 effects.

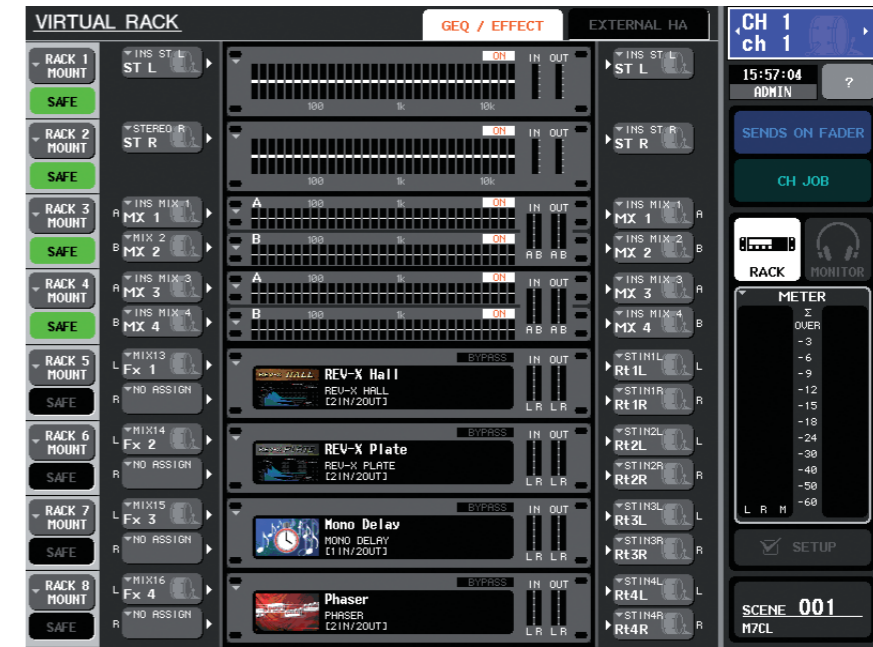

High-resolution Effects

Yamaha digital effects are highly regarded in the professional sound field for a very good reason: they are simply the best. The M7CL gives you an outstanding range of top-quality effects from ambience and echo to modulation and distortion. Whether you simply need to add a touch of natural-sounding reverb or manipulate a sound for other-worldly effect, the M7CL offers everything you need built in and ready to roll. The M7CL also comes with Yamaha’s superlative Add-on Effects REV-X package, providing some of the best, most natural-sounding ambience effects available anywhere.

Standard or Flex15 GEQ

The M7CL’s standard graphic EQ modules offer a full 31 bands for precise response shaping and feedback control. If your application requires even more EQ capability than the standard EQ modules

provide, the M7CL offers Flex15 GEQ: each GEQ module functions as two 31-band units with 15-bands available at a time. You can use up to 16 channels of Flex15 GEQ!

Direct EQ Control

The M7CL makes adjusting any of the 31 bands on the graphic equalizer modules direct and easy. Simply touch the EQ unit you want to adjust in the virtual on-screen rack, touch one of the band selectors, then use the 8 Centralogic™ faders to directly adjust the corresponding EQ bands. Other convenient-control features include the ability to instantly reset any band to nominal simply by pressing the appropriate [ON] key.



The Time To Go Digital Is Now

If you're planning to build or upgrade a mid-size sound system – installed or portable – now's the time to move up to a top-performance, easy-operation digital system based on the M7CL. This is one digital mixing console that lets you concentrate on sound without being overwhelmed by the technology.

- 48 or 32 mono microphone/line inputs, 4 stereo inputs, and 3 mini-YGDAI card slots (a total of 56 or 40 mixing channels).
- 16 mix buses, LCR bus, 8 matrix channels, and 8 DCAs assignable to 16 omni outputs.
- Virtual effect and EQ rack: up to 4 simultaneous multi-effect processors; up to 8 simultaneous 31-band graphic EQs.
- Centralogic™ interface: central, logical, and intuitive.
- Dual power modes: use the built in power supply, or add an external PW800W power supply unit (optional) for failsafe dual-supply operation.
- Compact and lightweight: 48 channels in the space and weight normally required for 24.



DIGITAL MIXING CONSOLE **M7CL-32**



DIGITAL MIXING CONSOLE **M7CL-48**

Advanced Mixing Functions Made Easy

Easy-access Channel Controls

All M7CL channel controls are conveniently organized in just three categories according to operational frequency and importance: physically controls for all channels that are always immediately visible and accessible, physical and display controls that provide direct access to the parameters of the currently selected channel or channel group, and “in-depth” parameters that reside just one level below the main display screens. A combination of this highly logical approach to control organization and a revolutionary interface design, the M7CL makes comprehension and operation of even advanced mixing functions easier than ever.

■ Channel Faders

The channel faders are the controls you’ll use most for just about all mixing applications, and that’s why the M7CL provides independent full-length (100-millimeter) motor faders for all mono and stereo input channels as well as stereo/mono masters. You can see all channel faders at all times, and simply reach out and grab any that you want to adjust. Each channel fader also has an [ON] key, a [CUE] key for cue monitoring, and a [SEL] key that assigns that channel to the Selected Channel controls (see below). Each input channel also has a 6-segment level meter for easy visual level monitoring.

■ Centralogic™ Navigation & Physical Controls

The 8 Centralogic™ faders are of the same type as the primary channel faders, with the same [ON], [CUE], and [SEL] keys and level meters. Simply press the appropriate Centralogic™ navigation key to bring control of any group of 8 input channel faders to the Centralogic™ controls and Overview display. The multi-function encoders at the top of each Centralogic™ control strip are used to control the parameters you “focus” on by touching the appropriate area of the Overview display.

■ Selected Channel & Touch-panel Display Controls

Accessing the mix and processing functions for each channel is easy, too: either press the [SEL] key of the channel you want to control and use the appropriate Selected Channel encoder to adjust as required, or use the touch-panel display and Centralogic™ controls as described above. Both methods give you easy access to the following parameters, and more:

• HA

Adjusts input-channel head amplifier (pre-amplifier) gain. Here’s where you match the channel’s input sensitivity to the source microphone or line input. HA gain is recallable like almost all of the console’s other settings. Touch the HA section of the display to access the +48V phantom power and phase settings.

• PAN

Pan control for mono input channels; balance control for stereo channels or mix channels assigned as pairs. Touch the PAN section of the display to access the TO STEREO and TO MONO ON/OFF settings.

• DYNAMICS 1 and DYNAMICS 2

DYNAMICS 1 adjusts gate threshold level for input channels, or compressor threshold level for mix, matrix, or stereo/mono channels. DYNAMICS 2 adjusts compressor threshold level for input channels. In either case the actual parameter controlled depends on the dynamics processor selected from the well-stocked dynamics library provided – including de-esser for advanced vocal processing. Although initially set up for gate + compressor processing, you can also use dual compressors. Touch the DYNAMICS 1 or DYNAMICS 2 section of the display to access the remaining comp and gate parameters as well as the DYNAMICS preset library.



• HPF

Adjusts high-pass filter cutoff frequency for input channels.

• EQ

This very versatile 4-band parametric EQ section affords extraordinary equalization control and quality for all inputs and buses.

Touch the EQ section of the display to access the $-\infty \sim +24\text{dB}$ ATT (level adjust) function.



• MIX / MATRIX

These are the send controls for the console’s 16 mix buses and 8 matrices. Depending on your application you can think of them as auxiliary, monitor, effect send, or group controls. AUX SEND (VARI) pre-attenuator and pre/post-fader modes are provided for auxiliary send applications, and a GROUP (MIX) mode is provided for convenient group send operation. There’s also an INPUT TO MATRIX mode that lets you send the input channel signals directly to the matrix.



Variable Direct Outputs

In addition to the bus outputs the M7CL provides direct outputs with selectable pre-EQ or pre-HPF output points. It also features variable-level direct output capability that can be used to optimally feed stereo or multitrack recording gear. Although the M7CL is basically a live sound console, the ability to conveniently make high-quality “off-the-board” recordings can be a great advantage.

Easy Channel Identification

Although this is an easy feature to overlook, it is vitally important for fast, error-free operation, particularly for live sound mixing. Channel names and icons appear at the top and bottom of every channel in the Overview display, and by simply touching one you can select one of the preset names provided or enter your own via the convenient on-screen keyboard. There’s even an excellent selection of icons you can choose from for easy visual identification of the source type.



Comprehensive Setup Libraries

Yamaha’s concept of using “libraries” to store presets for major console functions means you have extensive resources to draw on when setting up effects, parametric EQ, graphic EQ, or dynamics processing. You can load an appropriate preset and use it as is or tweak it to optimally match the source – examples: you might load a vocal compressor preset from the dynamics library and then adjust the threshold, or load a kick-drum EQ preset and nudge the center frequency to match the instrument actually being used. Of course you can also save your edited versions of the presets for easy recall whenever they’re needed again.

Versatile Monitoring and Monitor Mixing

Touch the MONITOR button on the display for full access to all of the M7CL monitor functions, from monitor source selection through talkback and oscillator controls. A headphone jack and level control are conveniently located on the console’s front panel. There’s also a dedicated talkback mic input and level control, but any of the input channels can be assigned to talkback operation for convenient system testing. And of course independent physical [CUE] buttons are provided with each fader for instant, error-free cue monitoring.



Straightforward Connections & Patching

The M7CL rear panel looks pretty much like the rear panel on an analog console, with individual balanced inputs for each of the console’s input channels. All outputs are patched to the 16 OMNI OUT connectors (the main stereo L and R outputs are patched to OMNI OUT 15 and 16 by default). All you have to do is plug in your sources and output system and you’re ready to mix. If you need a different routing arrangement re-routing is easily accomplished via the M7CL’s straightforward digital patching interface, so you can set up the signal flow your application requires in a matter of minutes.



Sends On Fader

When working on a monitor mix, touch the SENDS ON FADER button on the display to instantly assign the selected mix bus sends to the faders so you can visually confirm send levels and adjust them with precision that only full-length linear faders can provide. Touch the SENDS ON FADER button again and you’re right back at the main mix.

Metering

Accurate fast-response metering for all channels and buses is easily accessible via the M7CL display. A variety of metering points can also be selected so you have comprehensive visual monitoring of signal levels throughout the entire console.



Programmable LED Dimmer

LED visibility depends to a large extent on ambient light conditions, and there are times when a brightly lit console can interfere with the audience’s enjoyment of a performance. To accommodate a wide range of lighting and performance situations the M7CL provides two LED brightness levels. To accommodate a wide range of lighting and performance situations the M7CL allows the brightness of the screen, panel indicators, and lamps to be adjusted individually, and two brightness setups can be memorized for instant recall.

Multiple Security Levels Make Operation Safe and Easy For Any Operator

Advanced Access Management

In many applications it is desirable to prevent unauthorized access to the console, or restrict access to a limited set of functions. Limiting access is a great way to prevent “accidents” during critical live performances, for example, and can minimize the need for direct supervision of inexperienced operators. Or you might have spent hours with an analyzer setting up the EQ to precisely tune the system for the room, and you probably won’t want those settings changed under any circumstances. The M7CL’s access management features can be a significant advantage for overall system administration.

■ Password or USB Key Access

User access can be controlled either via passwords or USB memory keys. The administrator can assign specific functions to each unique password or key, so the user only has to log onto the

console with the assigned password on insert the USB key to begin operation at the assigned level. USB memory keys can be easily created either directly via the console or a computer running the M7CL Editor applications software. USB memory keys are particularly handy because they can also be used to store the user’s scenes and other preferences.



Beyond Basic Operation ... When You Need In-depth Control

Store and Recall Up to 300 Scenes

A “scene” is a complete snapshot of all the console’s settings, and the M7CL’s 301-scene memory lets you store up to 300 complete scenes for instant recall whenever they’re needed. This makes it a snap to reset the entire console for band changes or difference scenes in a theatrical performance, for example. You could also store basic setups for a number of different types of shows your system may be required to handle, then recall and tweak the settings as required.



Library

Name	Number	Total
Scene Memory	Preset 1 + User 300	301
Input EQ Library	Preset 40 + User 159	199
Output EQ Library	Preset 3 + User 196	199
Dynamics Library	Preset 40 + User 154	199
Effect Library	Preset 48 + User 151	199
GEQ Library	Preset 1 + User 198	199

■ Recall Focus and Recall Safe Functions

The M7CL takes scene functionality to a new level with recall focus and recall safe functions: recall focus lets you specify the parameters to be recalled with each scene, while recall safe works from the other perspective, allowing you to specify parameters that are not to be recalled with a scene. There are actually two kinds of recall safe: global recall safe specifies parameters that will not be changed when any scene is recalled, and scene-specific safe parameters that will not be changed when a specified scene is recalled. You could, for example, use global recall safe to prevent

any scene recall operation from changing a critical overall EQ setting, or use safe parameter settings to prevent the vocal channel fader setting from being changed by recall of a specific scene.

USB Memory for Convenient Data Management and Portability

Standard USB memory sticks can be plugged into the M7CL USB port for convenient storage and recall of a range of data: scenes, patches, user libraries, channel names, preferences ... essentially all system data. In addition to providing a secure backup, this makes it easy to transfer data between the console and the M7CL Editor application running on your personal computer, or directly between M7CL consoles. You can program the console’s settings using the M7CL Editor on a computer in your hotel room or on the tour bus – wherever you don’t have access to the console itself – and simply transfer those settings from your USB memory to the console at the venue.

Unlimited Channel Linking

There will undoubtedly be times when you’ll want to link a pair of faders to handle stereo signals, or perhaps even link more channels for simultaneous operation. The M7CL lets you link as many channels together as you like, and even deselect parameters that you don’t want to be linked. You might want to link a number of channels together but retain individual control over the channel EQ, for example. You can quickly and easily create as many pairs or linked groups as your application requires.



DCA Groups

While linked channel faders are directly adjusted via the channel faders themselves, the levels of channels assigned to a DCA group are controlled from one of the console’s DCA faders in the Centralogic™ control area. Any number of channel faders can be assigned to any of the console’s 8 DCA faders. This is not only convenient for central single-fader control of channel groups, but it also means you don’t have to use any of the console’s bus resources for channel grouping.

Mute Groups

Mute grouping is another feature that can be great advantage in live-sound applications. Any number of channels can be muted or unmuted via assigned User Defined Keys (see below). Up to 8 mute groups can be specified.

Channel Copy, Move and Clear

Features like these add significantly to the attraction of digital technology for live sound. The Channel Copy function lets you copy the parameters from any one channel to any number of other channels, Channel Move swaps the parameters between two specified channels, and Channel Clear clears all parameters of the specified channels. All of these capabilities can dramatically streamline the process of setting up the console or modifying the console settings.

Bus Setup

Each of the M7CL mix buses can be quickly assigned for mono or stereo operation. You also have a choice of pre/post-attenuator or pre/post-fader or variable send, and pre/post-pan settings for fixed send. Pre-EQ send can be an advantage when using the mix buses to feed an in-ear monitor system, for example.

Output Port Delay and Phase

Another feature that makes the M7CL a valuable asset for many live sound systems is built-in output delay and phase adjustment facilities on each output port. This lets you set up precise speaker distance compensation without the need for bulky, expensive external compensation equipment.

Bus Cascade Capability

The M7CL allows full bus cascading – including the CUE bus – for easy system expansion using a second M7CL console or a wide range of other console types.



User Defined Keys

As their name suggests, the 12 M7CL User Defined Keys can be user-defined to perform a range of handy functions. You could assign one for tap-tempo input of delay times, others to jump to specific display screens, or to control specified mute groups as described above. An innovative User Defined Key function is “Set by SEL”, with which the channel [SEL] keys perform a range of alternate functions if pressed while the assigned User Defined Key is held: reset the defaults for that channel, turn phantom power on or off, set the channel fader to nominal ... and more. Although you can set them up as required, the User Defined Keys have the following pre-assigned default functions: keys 1 through 8 select the corresponding mix buses for the SENDS ON FADER function, keys 9 and 10 are the mute masters for mute groups 1 and 2, key 11 clears all cue settings, and key 12 is talkback.



M7CL Editor Software

The M7CL Editor application for Windows operating systems gives you off-line programming access to all console parameters. You can set up and edit console parameters anywhere you can use your personal computer – in the office, on the road, in your hotel. A comprehensive graphical interface makes locating and editing parameters easy, and you can download setups from the computer to the console either by directly connecting the computer to the console via an Ethernet cable, or by saving the data to a USB memory stick that can then be plugged into the console's USB port. You can even control the console from the computer in real time while connected via Ethernet.



Overview
The Overview display offers a convenient view of the mix parameters for 16 channels or mix buses at a time.



Selected Channel
Similar to the Selected Channel display on the console, this display provides comprehensive access to all parameters for the selected channel. Multiple "Additional Views" for other channels can be opened simultaneously.

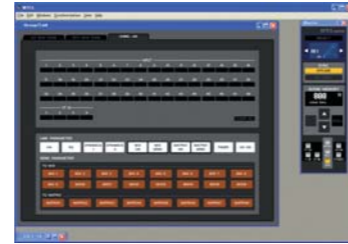

Group/Link
Channel linking can quickly and efficiently be accomplished on the console itself, but if you need to create channel link or group setups offline, the M7CL Editor makes the task easy.



Rack
The M7CL Editor Rack display is essentially the same as the console display, allowing smooth, intuitive effect assignment and editing.



Library
The M7CL Editor allows convenient data library management, too: shown here is the effect library display, complete with high-quality REV-X ambience effects.



Scene
You also have full access to scene functions with the M7CL Editor, including the focus and recall safe functions that allow exceptional control over the parameters that will be included and excluded when a scene is recalled.

Rear Panel

M7CL-32



M7CL-48



Options

Mini-YGDAI Expansion Cards

The M7CL has 3 expansion slots on the rear panel that accept a wide range of optional Yamaha mini-YGDAI I/O cards that can be used to add analog and/or digital input and output capability in a range of formats. You could add mini-YGDAI cards to connect to an MTR for direct multitrack recording, or to connect an Aviom personal monitoring system, for example. You can even use mini-YGDAI cards to bus-cascade the M7CL with other consoles for significantly expanded input/output capacity.



Option Input/Output miniYGDAI slot x3

	mini-YGDAI card Name	Function	Input	Output	The number of Available cards
	MY8-AE	AES/EBU	8In	8Out	3
	MY8-AT	ADAT	8In	8Out	3
	MY8-TD	TASCAM	8In	8Out	3
	MY4-AD	Analog In	4In	—	3
	MY8-AD24	Analog In	8In	—	3
	MY8-AD96	Analog In	8In	—	3
	MY4-DA	Analog Out	—	4Out	3
	MY8-DA96	Analog Out	—	8Out	3
Yamaha	MY8-ADDA96	Analog In/Out	8In	8Out	3
	MY8-AE96	AES/EBU	8In	8Out	3
	MY8-AE96S	AES/EBU	8In	8Out	3
	MY16-AT	ADAT	16In	16Out	3
	MY16-TD	TASCAM	16In	16Out	3
	MY16-AE	AES/EBU	16In	16Out	3
	MY16-C	Cobra	16In	16Out	3
	MY16-mLAN	mLAN	16In	16Out	3
AVIOM	16/o-Y1	AVIOM A-Net	—	16Out	3
AuviTran	AVY16-ES	EtherSound	16In	16Out	3
Audio-Service	MYMADI64	MADI	48In	48Out	1set (3)

MBM7CL Meter Bridge

Although the M7CL has comprehensive metering facilities built in (simply touch the meter section on the display for full-screen total-system visual monitoring), the optional MBM7CL Meter Bridge fits right above the console's display and provides high-visibility level monitoring while allowing the display to be used for other operations.



PW800W Power Supply Unit

For many applications you can simply plug the M7CL directly into a convenient AC outlet and use the built-in power supply. But you should consider the external PW800W Power Supply Unit in situations where maximum regulation and reliability are required. When a PW800W unit is added the internal power supply and the PW800W provide redundant failsafe operation.



M7CL Specifications

General Specifications

Sampling Frequency	Internal: 44.1kHz, 48kHz External: 44.1kHz (-10%) to 48kHz (+6%)0
Signal Delay	Less than 2.5ms INPUT to STEREO A, B (@ Sampling frequency = 48kHz)
Fader	100mm motorized x62 (46)
Touch Screen LCD	800 x 600 dot TFT LCD
Total Harmonic Distortion*	INPUT to STEREO A Less than 0.05% 20Hz to 20kHz @+4dBu into 600Ω
Frequency Response	INPUT to STEREO A 0.5, -1.5dB 20Hz to 20kHz @+4dBu into 600Ω
Dynamic Range	110dB typ. DA Converter (STEREO A) 108dB typ. AD+DA (to STEREO A)

Hum & Noise**	-128dBu typ. Equivalent Input Noise -86dBu residual output noise (STEREO A) STEREO Master off Master fader at nominal level and one input fader at nominal level
Maximum Voltage Gain	86dB INPUT1-48 to Each Output
Crosstalk (@1kHz)	-80dB adjacent input channels (INPUT1-48, ST IN 1-4 [L, R], OMNI OUT 1-16)
Phantom Power	48V
Dimensions (W x H x D mm)	M7CL-32: 1,060 x 286 x 701 (Included MBM7CL: 340) M7CL-48: 1,274 x 286 x 701 (Included MBM7CL: 340)
Net Weight	M7CL-32: 42kg M7CL-48: 50kg
Power Requirements	AC100-240V 50Hz/60Hz
Power Consumption	M7CL-32: 250W M7CL-48: 300W
Operation free-air Temperature Range	+10°C to +35°C
Storage Temperature Range	-20°C to +60°C

*Total Harmonic Distortion is measured with a 18dB/octave filter @80kHz
**Hum & Noise is measured with 6dB/octave filter @12.7kHz; Equivalent to a 20kHz filter with infinite dB/octave attenuation.

Analog Input Characteristics

Input Terminals	GAIN	Actual Load Impedance	For Use With Nominal	Input Level			Connector
				Sensitivity *1	Nominal	Max. Before Clip	
INPUT 1-32 <M7CL-32>	-62dB	3kΩ	50-600Ω Mics & 600Ω Lines	-82dBu (6.16μV)	-62dBu (0.616mV)	-42dBu (6.16mV)	XLR-3-31 type (Balanced) *2
INPUT 1-48 <M7CL-48>	+10dB	3kΩ	50-600Ω Mics & 600Ω Lines	-10dBu (245mV)	+10dBu (2.45V)	+30dBu (24.5V)	
ST IN 1-4 [L, R]	-62dB	3kΩ	50-600Ω Mics & 600Ω Lines	-82dBu (6.16μV)	-62dBu (0.616mV)	-42dBu (6.16mV)	XLR-3-31 type (Balanced) *2
TALKBACK	+10dB	3kΩ	50-600Ω Mics & 600Ω Lines	-10dBu (245mV)	+10dBu (2.45V)	+30dBu (24.5V)	
TALKBACK	-60dB	3kΩ	50-600Ω Mics & 600Ω Lines	-70dBu (0.245mV)	-60dBu (0.775mV)	-40dBu (7.75mV)	XLR-3-31 type (Balanced) *2
	-16dB	3kΩ	50-600Ω Mics & 600Ω Lines	-26dBu (38.8mV)	-16dBu (0.123V)	+4dBu (1.23V)	

*1. Sensitivity is the lowest level that will produce an output of +4dBu (1.23V) or the nominal output level when the unit is set to maximum gain. (all faders and level controls are maximum position.)
*2. XLR-3-31 type connectors are balanced. (1 = GND, 2 = HOT, 3 = COLD)
*3. In these specifications, 0dBu = 0.775 Vrms.
*4. All input AD converters are 24bit linear, 128times oversampling.
*5. +48V DC (phantom power) is supplied to INPUT (1-48), ST IN 1L-4R, TALKBACK XLR type connectors via each individual software controlled switches.

Analog Output Characteristics

Output Terminals	Actual Source Impedance	For Use With Nominal	GAIN SW *5	Output Level		Connector
				Nominal	Max. Before Clip	
OMNI OUT 1-16	75Ω	600Ω Lines	+24dB (default)	+4dBu (1.23 V)	+24dBu (12.28V)	XLR-3-32 Type (Balanced) *1
			+18dB	-2dBu (616mV)	+18dBu (6.16V)	
PHONES	15Ω	8Ω Phones 40Ω Phones	-	75mW *6	150mW	Stereo Phone Jack (TRS) (Unbalanced) *2
			-	65mW *6	150mW	

*1. XLR-3-32 type connectors are balanced. (1 = GND, 2 = HOT, 3 = COLD)
*2. PHONES stereo phone jack is unbalanced. (Tip = LEFT, Ring = RIGHT, Sleeve = GND)
*3. In these specifications, 0dBu = 0.775 Vrms.
*4. All output DA converters are 24bit, 128times @48kHz) oversampling.
*5. There are switches inside the body to preset the maximum output level.
*6. The position of the level control is 10dB lowered from Max.

Digital Output Characteristics

Terminal	Format	Data Length	Level	Connector
2TR OUT DIGITAL	AES/EBU *1 Professional Use	24bit *2	RS422	XLR-3-32 Type (Balanced) *3

*1. Channel status of 2TR OUT DIGITAL
*2. Dither: word length 16/20/24 bit
*3. XLR-3-32 type connectors are balanced. (1 = GND, 2 = HOT, 3 = COLD)

Control Input/Output Characteristics

Terminal	Format	Level	Connector
MIDI	IN	MIDI	DIN Connector 5P
	OUT	MIDI	DIN Connector 5P
WORD CLOCK	IN	TTL/75Ω Terminated	BNC Connector
	OUT	TTL/75Ω	BNC Connector
REMOTE	-	RS422	D Sub Connector 9P (Male)
Ethernet	Ethernet	100Base-T	RJ-45
LAMP 1, [2]	-	0V-12V	XLR-4-31 type *1
USB	USB 1.1 Host *5	USB *6	A type USB Connector (Female)
DC POWER INPUT	-	-	JL05 Connector

*1. 4pin = HOT, 3pin = COLD, lamp rated powered 5W Voltage can be adjust by a software.

Dimensions

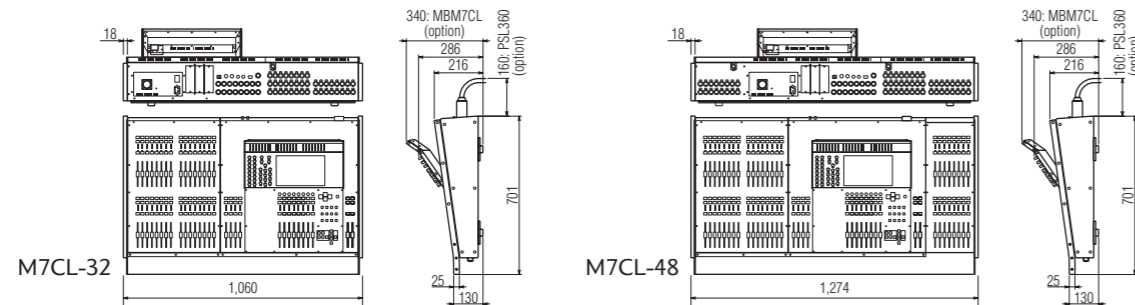

Block Diagram

