

IPS10E-I INFRASUB™

SELF-POWERED & SELF INFRA™ PROCESSED

APPLICATIONS

Laboratory Reference System	House of Worship
Recording Studio and Mastering	Theatrical Sound Reinforcement
Post Production and Screening Room	Installed Audio-Visual Systems
Restaurant Foreground Music Systems	Nightclub Installation

DESCRIPTION

The IPS10E-I is a self-powered and internally Infra™ processed single 10" bass system designed for permanent installation. The internal Bag End® Minima 3™ amplifier and Infra™ processing provides for convenient implementation and wiring. The internal Infra™ integrator, amplifier and loudspeaker process the full range signal into a flat response low frequency acoustic output. The Dynamic Filter™ protection threshold is internally preset to eliminate distortion or accidental overload. This insures the maximum output and robust system protection with virtually no audible effect.

The audio input incorporates an InGenius® balanced line receiver, providing very high common mode rejection, to eliminate noise often present in systems with less optimized grounding and wiring schemes.



SPECIFICATIONS

System Type:

Infrasub™ sealed chamber 0.75 ft³

Enclosure:

18 mm 13-ply birch plywood

Finish:

Black Ro Tex™ True water born environmental finish

Grille:

16 Gauge black power coated perforated steel

Low Frequency Components:

EL-10 10" Transducer, Infra™ cone, 2.5" Voice coil, 68 oz. Magnet

Input Connector:

XLR 1/4" combo with XLR loop through

Internal Amplification:

Minima 3™

Input Impedance:

48K Ohms

Input CAL Sensitivity:

+4 dBu

Maximum Continuous Amplifier Power:

300 W into 4 Ohms

High Pass Filter:

Switchable: -6 dB @ 8 Hz; @ 50 Hz; @ 95 Hz

LED Indicators:

Green - On
Yellow - Dynamic filter threshold
Red - System fault or sleep mode

Mains Voltage Requirements:

Auto sensing
Universal voltage range
88 Volts minimum to 270 Volts maximum

Mains Current Requirements:

1.6 Amps @ 120 Volts
0.8 Amps @ 240 Volts

Hardware:

Optional F2 Fly points available with a safe working load of 200 lbs.

Crossover Type:

Internal Infra™ Integrator Inside

Frequency Response:

8 Hz to 95 Hz ±3 dB

Low Frequency Limit:

8 Hz

Maximum Calculated Continuous Acoustic Output:

Half Space @ 1 Meter
10 Hz - 79 dBSPL
20 Hz - 91 dBSPL
40 Hz - 103 dBSPL
80 Hz - 113 dBSPL

Polarity:

A positive asymmetrical signal applied to pin 2 will result in a positive asymmetrical acoustical pressure

Dimensions:

12.5" h x 14" w x 11.5" d
32 cm x 36 cm x 30 cm

Weight:

27 lbs
13 kg

Custom Finishes:

Optional custom finishes include white, unfinished ready to paint and outdoor weather treatment.

INFRA™, INFRASUB™, MINIMA ONE™ and DYNAMIC FILTER™ are trademarks of Modular Sound Systems, Inc.
BAG END® is a registered trademark of Bag End, Inc.

IPS10E-1 INFRASUB™

ABOUT INFRASUB™ TECHNOLOGY

Almost all designs and specifications for subwoofer systems are fixated on the frequency response domain. However, the impression of power and quality of a loudspeaker is equally related to the time domain. The long wavelengths associated with low frequencies make this particularly true with subwoofers. Likewise, the maximum SPL is not a very reliable way to judge the impact of a subwoofer. A poor time domain performer will not have the same impact or natural musically connected sound as a Time-Aligned™ Infra™ system. The reason that an Infra™ subwoofer sounds dramatically better is because of their superior time domain performance, as well as their extended low frequency response. The Infra™ subwoofer maintains the bass energy in a tight packet, aligned with the upper range signal, providing a greater body impact and a seamless musical connection with the main loudspeakers. Conventional subwoofer designs perform so poorly in the time domain because designers have used methods that sacrifice the phase response for more control over the frequency response (e.g.: steep low pass filter slopes, vented speaker enclosures, and narrow bandwidth systems). With the Infra™ technique, we do not degrade the phase response while extending the frequency response.

While the Infra™ dual Integrator does function as the system crossover, it does so without using a conventional low pass filter. The Infra™ integrator applies an inverse electrical response to the acoustical response of the Infra™ loudspeaker in its sealed enclosure. This provides the extended frequency

response while maintaining the hi sound quality often associated with a sealed box design. This design approach requires the most amplifier power to be used at the lowest frequency, thus we implement the Dynamic Filter™ technology to protect the system from the bottom up, affecting the lowest frequency first and leaving the middle and upper bass unaffected. The Dynamic Filter™ is a complimentary technology to the Infra™ system taking unique advantage of the Infra™ design approach, to implement a reliable protection scheme that is transparent and inaudible to the listener. When comparing a genuine Bag End® Infra™ loudspeaker system to any other, our technology and design is easy to hear and appreciate. The dramatic clarity, realism, and overall pleasant sound of an Infra™ system is well noted throughout the world.

ABOUT MINIMA 3™ SELF POWERED

The Minima™ amplifier is both a high fidelity and a high efficiency amplifier. With efficiency well over 80%, it provides more power to the loudspeakers, and creates less heat in the amplifier. In real world applications there is practically no heat emitted from the amplifier and thus it requires no cooling fan. The AC power input automatically adapts to any voltage between 88 and 270 volts.

ABOUT DYNAMIC FILTER™

The Dynamic Filter™ is a complimentary technology to the Infra™ system taking unique advantage of the Infra™ design approach, to implement a reliable protection

scheme that is transparent and inaudible to the listener. Systems using the external rack mount Infra-MXB processor require an appropriate threshold adjustment that sets the amplifiers power and sensitivity to the Infra™ loudspeakers in use. When a system is asked to do more than it is capable of, or if an accidentally large signal is presented the threshold of the Dynamic Filter™ is crossed and the system protects itself from the bottom up by reducing the lowest frequencies first. Since the most power and excursion is always required at the lowest frequency, reducing the level of the lowest frequencies first avoids an overload, while at the same time the system is able to reproduce the middle and upper bass and leave the upper crossover region unaffected. This is a very natural and inaudible method to protect the system and unique to the Infra™ technology.

ABOUT BAG END® LOUDSPEAKERS

Bag End loudspeakers began in 1976 in a small shop by people dedicated to the pursuit of making high quality loudspeaker systems. Over the decades Bag End® has employed the very best construction techniques and innovative acoustical designs into their products. The ground breaking introductions of the Time-Align® and ELF™ Technologies into sound reinforcement and studio monitor loudspeakers in the 1980's was followed by Minima One™ self-powered systems and the highly unique E-Trap™, electronic bass trap. Over the decades, Bag End® has been a leader in providing uniquely good sounding products and extraordinary service to our customers world wide.

DIMENSIONS

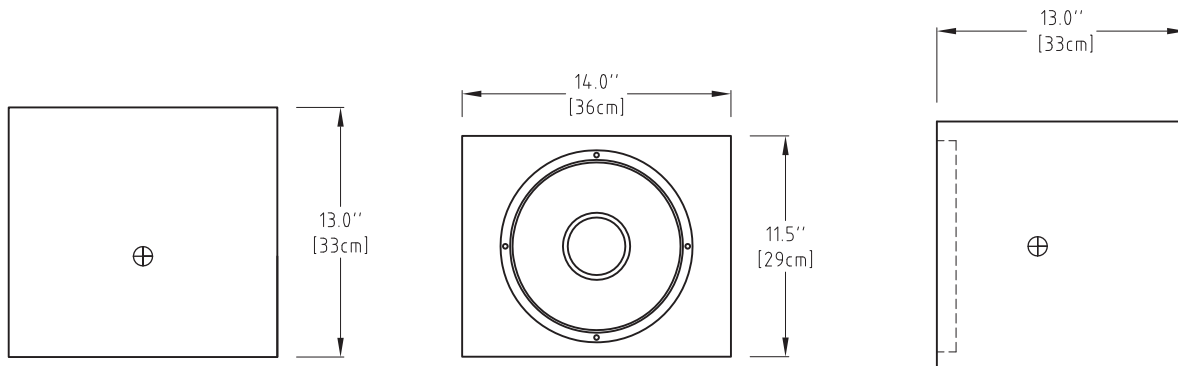

⊕ = Center of Gravity

