

Wallplate Control Interface for DM Series



The RCWPB4 is a control interface for Lectrosonics DM Series processors to provide a variety of remote control operations. The unit is connected to the 25-pin D-sub connector on the rear panel of a DM Series processor. As each button is pressed, an operation is triggered on the processor and the LED on the wallplate illuminates.

The most common use is to make changes in the setup of a DM Series processor by launching macros and recalling presets. When the button is pressed the associated LED lights up and stays lit until another button is pressed so that the LED indicates the current state of the processor. Applications such as room combining are easily accomplished with preset recalls from a single button press.

Basic Operation

Pressing buttons B1 thru B4 will send a pulse to the corresponding connector terminal and light the associated LED (L1 thru L4 respectively) and turn off all other LEDs. If the same button is repeatedly pressed, a pulse will be sent to the DM system at each press, and the corresponding LED will remain lit; it does not toggle. For this reason, the RCWPB4 is intended to be used as a "State Indicator" showing the user which state was last executed. Space has been provided next to each LED for labeling.

External LED Control

As an alternate configuration, you can use connector pins 6 and 7 to allow a DM processor to control LED's 1 & 3 instead of button presses on the RCWPB4 itself. This will allow the LEDs to indicate events that occur in the DM processor. To configure the unit for this mode, remove the corresponding jumper EXT 1 (for LED 1) or EXT 2 (for LED 3) and wire the connector pin 6 or 7 to the appropriate Programmable Output Pin on the DM processor. Then configure the Programmable Output Pin with the DM processor control panel. The programmable output will latch to ground, allowing the LED to light when the associated event takes place.

Basic Room Combining

A typical application for the RCWPB4 is wiring each of its outputs (pins 2 – 5) to programmable inputs on the DM, and using the button press pulses to recall presets such as those used for room combining. Each button would correspond to a specific room setup, and the LEDs would indicate the current room combination.

Triggering Macros and Indicating DM Processor Events

Another application consists of wiring the RCWPB4's outputs (pins 2 – 5) to programmable inputs on a DM processor to launch macros, but allowing the DM to control LED's 1 & 3 in response to certain events. Both EXT 1 & EXT 2 jumpers should be removed and connector pins 6 & 7 wired to DM's programmable outputs as described above.

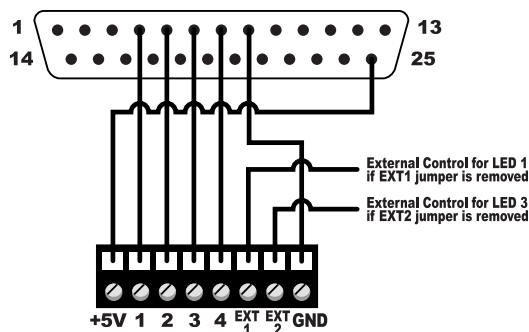

Front

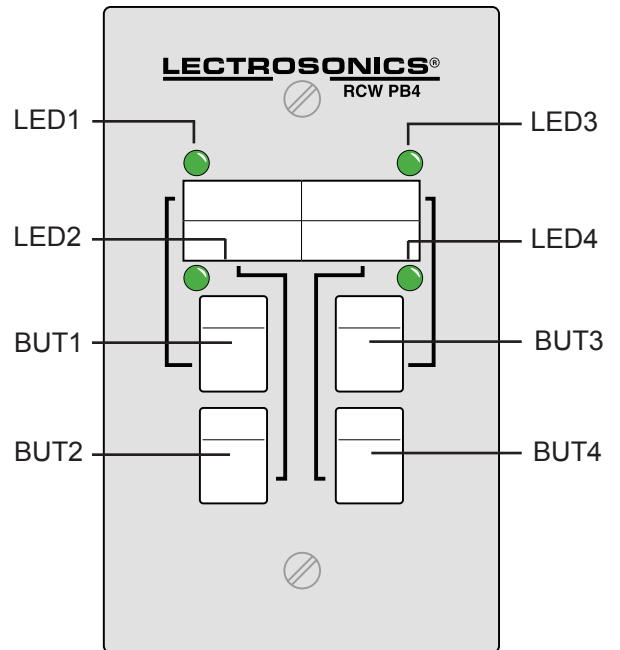

Rear

