



RRM16UW

Good construction doesn't go out of style. That's our MO and that's why we create cases that are done right. Designed with a 10U slanted top rack for convenient mixer/CD controller placement and a 16U vertical rack for amp. or effect units, the RRM16U is built right. The RRM16U features an 18" mountable rack depth and 2 heavy-duty removable covers. To make a good thing even better we added an unique removable, rear hinged door for easy access to your gear. We even included a heavy-duty 3 1/2" caster kit for easy mobility. At last, connections without a hassle.

Rugged Road Ready Features

- * Beefy, Stackable Ball Corners
- * Double Anchor Industrial Rivets
- * Recessed, Industrial Grade Latches
- * Recessed, Spring Loaded Handles
- * Industrial Grade Rubber Feet
- * Premium 3/8" Vinyl Laminated Plywood
- * Tongue and Groove Locking Fit
- * Heavy Duty Rack Rails
- * Hinged Rear Access Door
- * Heavy Duty 3 1/2" Caster Kit
- * Mounting Hardware Included
- * ATA 300 Rating
- * Road Ready Limited Lifetime Warranty

Shipping Dimensions (inch): 22.4 x 25 x 41.7

Shipping Weight (lbs): 102.3 lbs

Product Dimensions (inch): 21.5 x 23.8 x 39.8

Product Weight (lbs): 90.6 lbs

Shipping Dimensions (cm): 57 x 63.5 x 106

Shipping Weight (kg): 46.5 kg

Product Dimensions (cm): 54.5 x 60.5 x 101

Product Weight (kg): 41.2 kg

10U Slant Mixer/16U Vertical Rack Case with Caster Kit

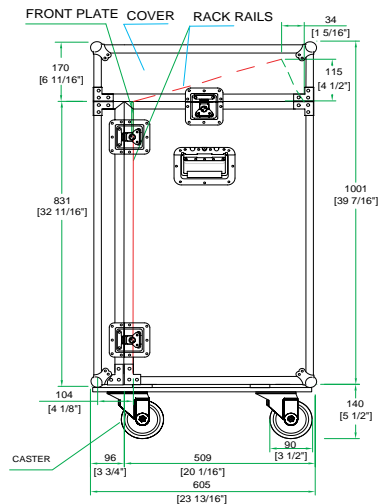

SIDE VIEW

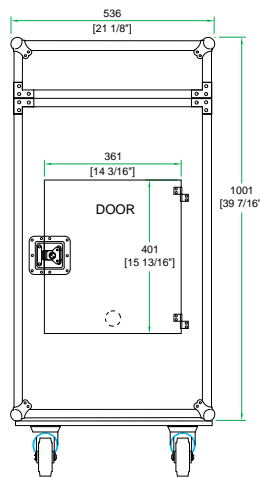

BACK VIEW

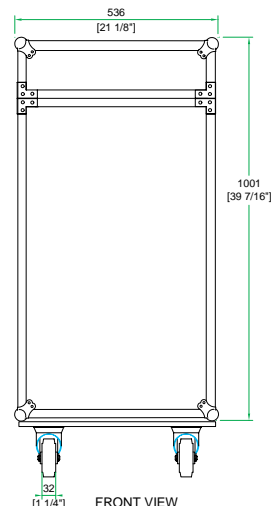

FRONT VIEW

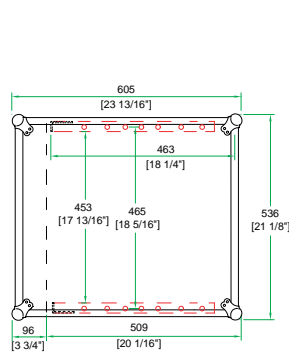

TOP VIEW

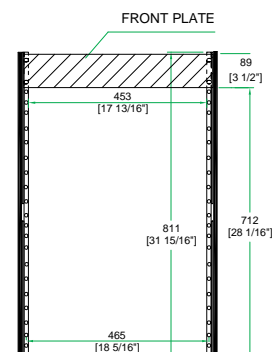

INSIDE VIEW

Need optional Road Ready Accessories to help outfit your Slant Rack? Check out our Road Ready Caster Kit (RRWAD), Rolling Base with Storage Drawer (RR6WD) and Road Ready Side Wings (RRMW)

www.roadreadycases.com

Road Ready Cases 18120 S. Broadway St. Unit B Gardena, Ca. 90248- 3536
 ph: 310 767 1772 fax: 310 767 1798