

# LynTec RPC

Instruction Bulletin

Remote  
Power  
Controller



Retain for future use.

## HAZARD CATEGORIES AND SPECIAL SYMBOLS

Read these instructions carefully and look at the equipment to become familiar with the device before trying to install, operate, service, or maintain it. The following special messages may appear throughout this bulletin or on the equipment to warn of potential hazards or to call attention to information that clarifies or simplifies a procedure.



The addition of either symbol to a "Danger" or "Warning" safety label indicates that an electrical hazard exists which will result in personal injury if the instructions are not followed.



This is the safety alert symbol. It is used to alert you to potential personal injury hazards. Obey all safety messages that follow this symbol to avoid possible injury or death.

### **DANGER**

DANGER indicates an immediately hazardous situation which, if not avoided, **will result in** death or serious injury.

### **WARNING**

WARNING indicates a potentially hazardous situation which, if not avoided, **can result in** death or serious injury.

### **CAUTION**

CAUTION indicates a potentially hazardous situation which, if not avoided, **can result in** minor or moderate injury.

### **CAUTION**

CAUTION, used without the safety alert symbol, indicates a potentially hazardous situation which, if not avoided, **can result in** property damage.

*NOTE: Provides additional information to clarify or simplify a procedure.*

## PLEASE NOTE

Electrical equipment should be installed, operated, serviced and maintained only by qualified electrical personnel. This document is not intended as an instruction manual for untrained persons. No responsibility is assumed by LynTec for any consequences arising out of the use of this manual.

## Class A FCC Statement

**Contents**

Chapter 1--Introduction..... 5

    OVERVIEW ..... 5

    CONTENTS ..... 5

        Controller overview..... 6

Chapter Two--Safety Precautions ..... 9

Chapter Three--Quick Start Guide..... 10

    Introduction ..... 10

Chapter 4--Wiring..... 11

    Additional Control Options..... 12

        Emergency Shutdown Wiring:..... 15

        Emergency Lighting Wiring:..... 16

        TCP/IP..... 17

        sACN ..... 17

        DMX ..... 17

        RS-232 ..... 17

        RS-485 ..... 17

        Switch Wiring Instructions..... 18

        LynTec SS-2 Switch Set ..... 18

        SS-2PL and SS-2LRP Locking Switch Sets ..... 19

    Initial Power up procedure..... 23

Chapter 5--Control Setup (Web Page)..... 24

    OVERVIEW ..... 24

    Status ..... 24

    Control ..... 24

    Setup..... 24

    Support..... 24

    event log ..... 24

Setup ..... 25

    Setup Home..... 25

Network setup ..... 26

Panel Setup ..... 29

    Breaker setup ..... 29

    Zone setup..... 30

    Global Preferences ..... 34

    Setup..... 34

        Labeling..... 34

        Numbering and addressing ..... 34

        Global Control Preferences..... 35

        Selecting breakers for Emergency Shutdown, Emergency Lighting or Brownout ..... 36

        Brownout Thresholds (optional) ..... 36

**RPC Controller**  
**Table of Contents**

Schedule Setup..... 37

Assigning Schedules to Zones..... 37

Contact Closure Setup ..... 38

Assigning Contact Closures to Zones ..... 38

Individual Momentary Contact ON and OFF Pushbuttons..... 39

I/OR Setup ..... 40

Email Alert Setup..... 41

Chapter Six: Operating your RPC..... 42

    Using the built-in web page..... 42

    Using a secondary controller ..... 42

Appendix A--RPC Quick Start Guides..... 43

    RPC to RPS Wiring Instructions..... 43

    RPC Quickstart Guide..... 45

    RPCR Quickstart Guide..... 47

    RPC Contact Closure Wiring Instructions ..... 49

Appendix B--RS-232 and TCP/IP Protocols ..... 51

    RS-232 Protocol..... 51

        Addressing Scheme..... 51

        Breaker Related Commands..... 51

        Zone Related Commands ..... 53

        Event Related Commands..... 54

        Checksum ..... 56

    TCP/IP Protocol..... 56

        Breaker Control = B ..... 56

        Zone Control = Z..... 56

        Events Control = E ..... 57

Appendix C--Troubleshooting ..... 58

    Troubleshooting the controller ..... 58

Appendix D--RPC System Components ..... 60

    Control Bus ..... 61

    Remotely Operated ..... 61

    Circuit Breakers ..... 61

    Power Supply..... 62

    Buffer..... 62

    Transducer ..... 62

    Controller ..... 63

    Slave Address Selector ..... 63

---

## Chapter 1--Introduction

### OVERVIEW

This bulletin explains how to install and operate the LynTec Remote Power Controller (RPC) and the RPCR relay panel. The controller uses remotely operated circuit breakers to control up to 167 remotely operated branch circuits. In the case of the RPCR, the controller can control up to 64 relays. Control signals originate externally from commands received via the communications network or from dry contact inputs. Acceptable communications protocols include TCP/IP, RS-232, sACN and DMX-512. RS-485 optional.

### CONTENTS

Each RPC comes standard with the following components installed:

- RPC Controller
- Power Supply
- Capacitive Buffer (optional on RPCR)
- Isolated technical ground (panels only)
- 15A unmotorized breaker(panels only)
- Voltage Transducer (panels only)

Optional additional components include:

- I/O expansion board
- I/O-R outbound relay control board
- Multi-panel expansion board (panels only)
- Current Monitoring (panels only)

**Controller overview**

Figure 1-1 shows the parts of the RPC controller. A brief description of each part follows in Table 1-1.

**Figure 1-1: RPC Controller**

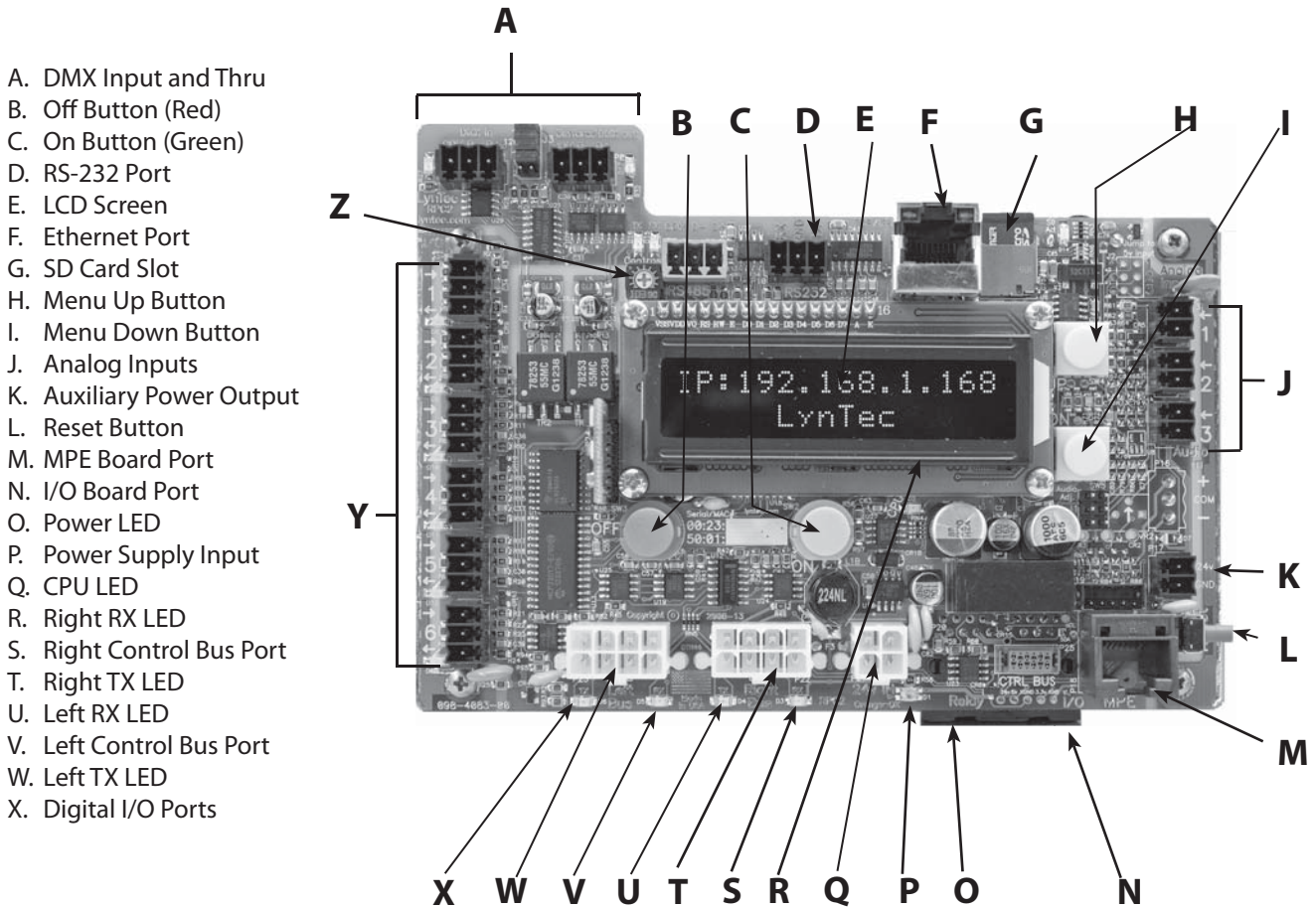

**Table 1-1: Parts of the RPC Controller**

Component	Description
A. DMX Input and Thru	Allows the panel to be directed by a secondary DMX controller. Indicator LED signal the receipt and transmission of DMX. When DMX is enabled, the control page is disabled.
B. OFF Button	Turns all breakers off
C. ON Button	Turns all breakers on
D. RS-232 Port	Control Port for secondary controller such as AMX or Crestron.
E. LCD Screen	Screen shows the IP address, time and setup information.
F. Ethernet Port	Connects the panel to a computer or network for initial setup or long-term operation using the built-in web interface. Port also provides sACN connection
G. microSD Card	Card slot for microSD card
H. Menu Up Button (yellow)	Scrolls the screen up.
I. Menu Down Button (yellow)	Scrolls the screen down.
J. Analog Inputs	Additional analog inputs to connect voltage/current monitors or light sensors.
K. Auxiliary Power Output	Auxiliary 24V power for accessories. Maximum allowable current--200mA
L. Reset Button	Resets the controller.
M. MPE Port	Connects the Multi Panel Expander Board (for use with up to 3 slave panels)

**Table 1-1: Parts of the RPC Controller**

Component	Description
N. I/O Board Port	Connects additional I/O boards to the controller. Up to two boards can be added for a total of 38 contact closure inputs. OR, the I/OR board may be added to provide outbound relay control
O. Relay Driver Port	Connects relay driver boards to the controller.
P. Power Led	Illuminates when the controller is receiving power.
Q. Power Supply Input	Connects the controller to the power supply.
R. CPU LED	CPU Heartbeat
S. Right RX LED	Flashes when the controller is receiving data from the local right control bus.
T. Right Control Bus Port	Connects the controller to the local right control bus.
U. Right TX LED	Flashes when the controller is transmitting data to the local right control bus.
V. Left RX LED	Flashes when the controller is receiving data from the local left control bus.
W. Left Control Bus Port	Connects the controller to the local left control bus.
X. Left TX LED	Flashes when the controller is transmitting data to the local left control bus.
Y. Digital I/O Ports	Contact closure input, indicator output, and 24VDC common
Z. LCD Contrast	Adjusts contrast on LCD screen (E)

**Figure 1-2: I/O Expander Board**

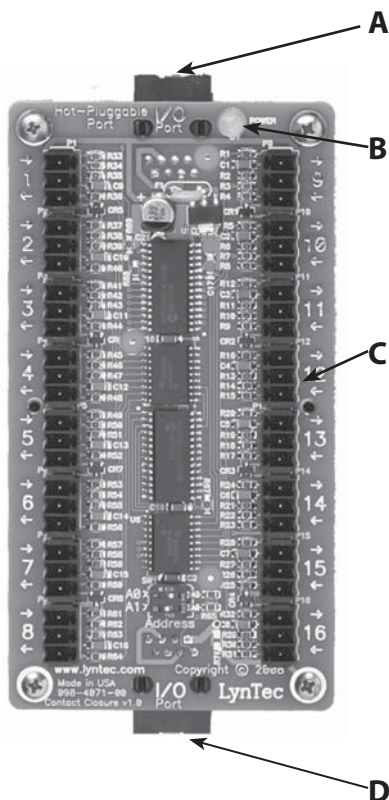

Figure 1–2 shows the parts of the I/O Board. A brief description of each part follows in Table 1–2.

**Table 1-2: Parts of the I/O Board**

Component	Description
A. I/O Control Port	Connects the board to the controller.
B. Power LED	The power LED is always on when the board is receiving power.
C. Digital I/O Headers	Allows the panel to be controlled by contact closure devices.
D. I/O Control Port Thru	Connects to an additional I/O expander board.

**Figure 1-3: Multi-Panel Expander Board**

Figure 1-3 shows the parts of the additional slave board. A brief description of each part follows in Table 1-3.

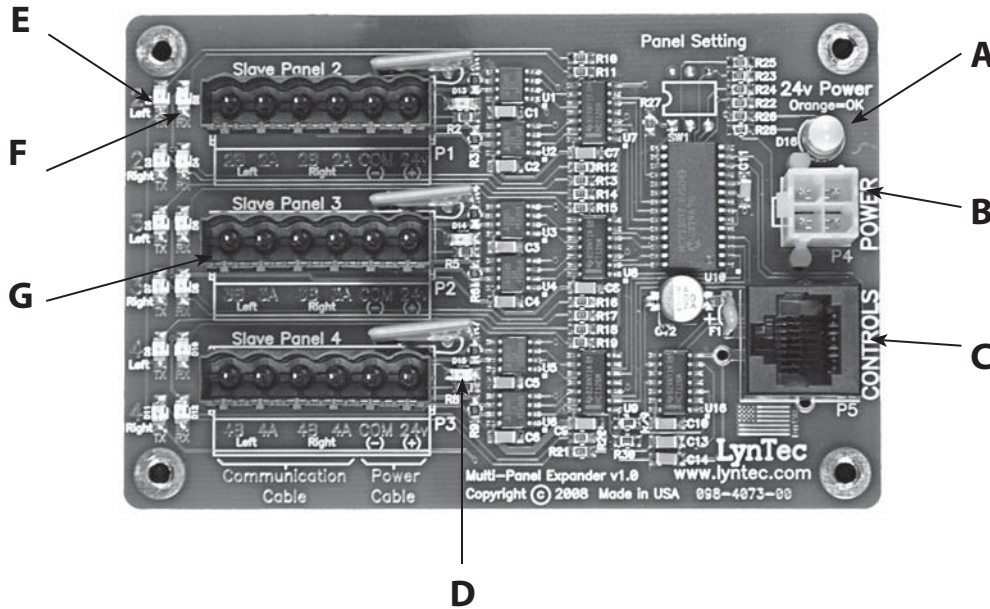

**Table 1-3: Parts of the Multi-Panel Expander Board**

Component	Description
A. Power LED	The power LED is always orange when the board is receiving power.
B. Power Input	Provides power to control busses on panels two, three and four.
C. Control Input	Receives control signal from control board.
D. Control Bus Indicator	Indicates that the control busses on panel two, three or four have power.
E. Data transmission indicator	Indicates that the Multi-Panel expander board is transmitting data to a particular control bus (example: panel 2 left).
F. Data reception indicator.	Indicates that the Multi-Panel Expander Board is receiving data from a particular control bus (example: panel 2 left)
G. Expansion Ports	Connects the MPE board to control busses on panels two, three and four.



---

## Chapter Two--Safety Precautions

This chapter contains important safety precautions that must be followed before attempting to install, service, or maintain electrical equipment. Carefully read and follow the safety precautions below.



### **DANGER**

#### **HAZARD OF ELECTRIC SHOCK, EXPLOSION, OR ARC FLASH**

- This equipment must be installed and serviced only by qualified electrical personnel.
- Apply appropriate personal protective equipment (PPE) and follow safe electrical work practices. See NFPA 70E.
- Turn off all power supplying this equipment before working on or inside equipment.
- Always use a properly rated voltage sensing device to confirm that power is off.
- Replace all devices, doors, and covers before turning on power to this equipment.
- Before energizing panelboard, all unused spaces must be filled with blank fillers.

**Failure to follow this instruction will result in death or serious injury.**

## Chapter Three--Quick Start Guide

### INTRODUCTION

This chapter is a quick reference listing the steps necessary to install the RPC system. The steps in this chapter are provided as an installation checklist. For complete installation instructions, refer the chapter listed.

Steps	Reference
1. Install all the RPC components according to their instruction bulletins. Typical components include, but are not limited to, the following: <ul style="list-style-type: none"> <li>• circuit breakers</li> <li>• controller</li> <li>• control bus</li> <li>• power supply</li> <li>• voltage transducer</li> <li>• slave address selectors</li> </ul>	See appropriate instruction bulletins.  <b>Chapter 4--Wiring</b>
2. Wire all RPC components according to their instruction bulletins.	See appropriate instruction bulletins.
3. Connect the controller to a computer or network for panel setup.	<b>Chapter 4--Wiring</b>
4. Access the web page by entering the IP address or NetBIOS name into web browser on the aforementioned computer.	<b>Chapter 5--Control Setup</b>
5. Complete the panel setup.	<b>Chapter 5--Control Setup</b>
6. Connect the controller to a secondary controller or add contact closures if necessary.	<b>Chapter 4--Wiring</b> <b>Chapter 5--Control Setup</b>
7. If your RPC system does not operate as expected, verify that everything is installed and programmed correctly.	<b>Appendix A--Troubleshooting</b>

## Chapter 4--Wiring

To initially wire the RPCR connect the power breaker in your panel to the transformer in the RPCR. For additional RPCR wiring, skip to page 14.

To initially wire the RPC follow these easy steps:

1. Install and connect all main and neutral feeds as per NEC.
2. Install and connect the Isolated Technical Ground feed from the star ground of the isolation transformer or the tie point from a ground rod or building steel to the Isolated Technical Ground bar in the ITG sidecar.
3. Ensure all breakers are properly installed in the panel and that the motorized breakers are firmly plugged into the adjacent control busses.

**Figure 4-1: Power Supply**

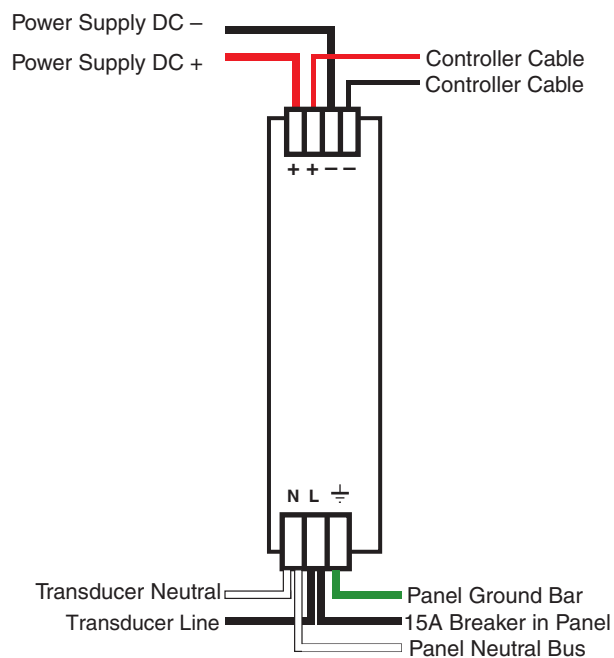

Steps four, five and six are completed at the factory. The instructions are included as a reference only.

4. Connect the black 14 AWG wire from the Line terminal of the Power Supply unit (Figure 4-1--located at the top of the Isolated Technical Ground sidecar) to the 15 Amp Controller Power breaker in the panel.
5. Connect the white 14 AWG wire from the Neutral terminal of the Power Supply unit to the neutral bus located below the breakers in the panel.

6. Connect the green 14 AWG wire from the ground terminal of the Power Supply unit to the ground bar attached directly to the panel (**DO NOT attach to the isolated technical ground in the sidcar**).
7. Install and connect all load, neutral and Isolated Technical Ground feeds to circuits.
8. Ensure that all bolts and lug connections in the panel are tight. Check both sides of the main breaker, the bars connecting the busses to the main and all breaker retaining bolts.
9. Check the cable connections at the top of the breaker control busses to ensure the connectors are properly seated.
10. Replace the dead front pan and cover with door.

## ADDITIONAL CONTROL OPTIONS

Additional circuit boards may be used to add additional panels or I/O inputs.

Figure 4-1: Multi Panel Expander

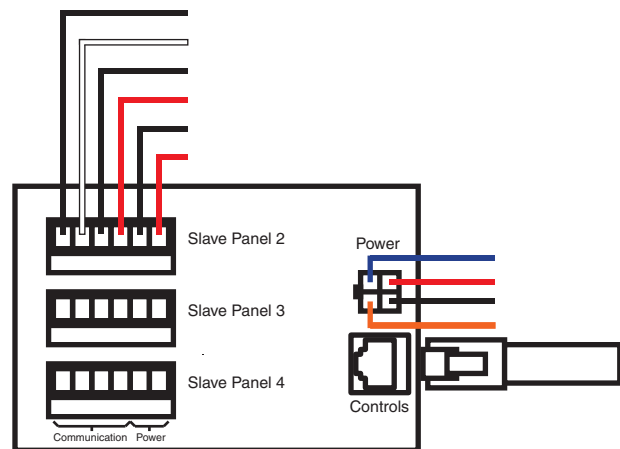

1. If RPS Slave panels are being used in conjunction with an RPC Master panel, install and connect one 18 AWG six (6) conductor, (Belden 27600 A or equivalent) or two 18-24 AWG twisted pairs for data and one 16-18 AWG for power per RPS unit. Terminate the Left Bus B, Left Bus A, Right Bus B, Right Bus A, Common (-) and 24VDC (+) in the screw-terminal header for that RPS (Slave Panel 2 – 4) from left to right. Cables must be rated to 600V.

2. At the RPS Slave panels, strip the cable sheath back approximately 20 inches. Cut the conductors for Left Bus B, Left Bus A, – and + down to approximately 4 inches and terminate them in the Left Bus screw-terminal header from left to right. Terminate the remaining two conductors in the Right Bus B and Right Bus A positions of the Right Bus screw-terminal header.
3. Using two cut lengths of 18 AWG wire, install jumpers from Left Bus – and + to Right Bus – and +. Right Bus will not operate without these jumpers installed to provide 24VDC power and common.
4. Set the slave address selectors as follows:

Table 4-2

	Left Control Bus	Right Control Bus
<b>Panel #2</b>	<b>2</b>	<b>3</b>
<b>Panel #3</b>	<b>4</b>	<b>5</b>
<b>Panel #4</b>	<b>6</b>	<b>7</b>

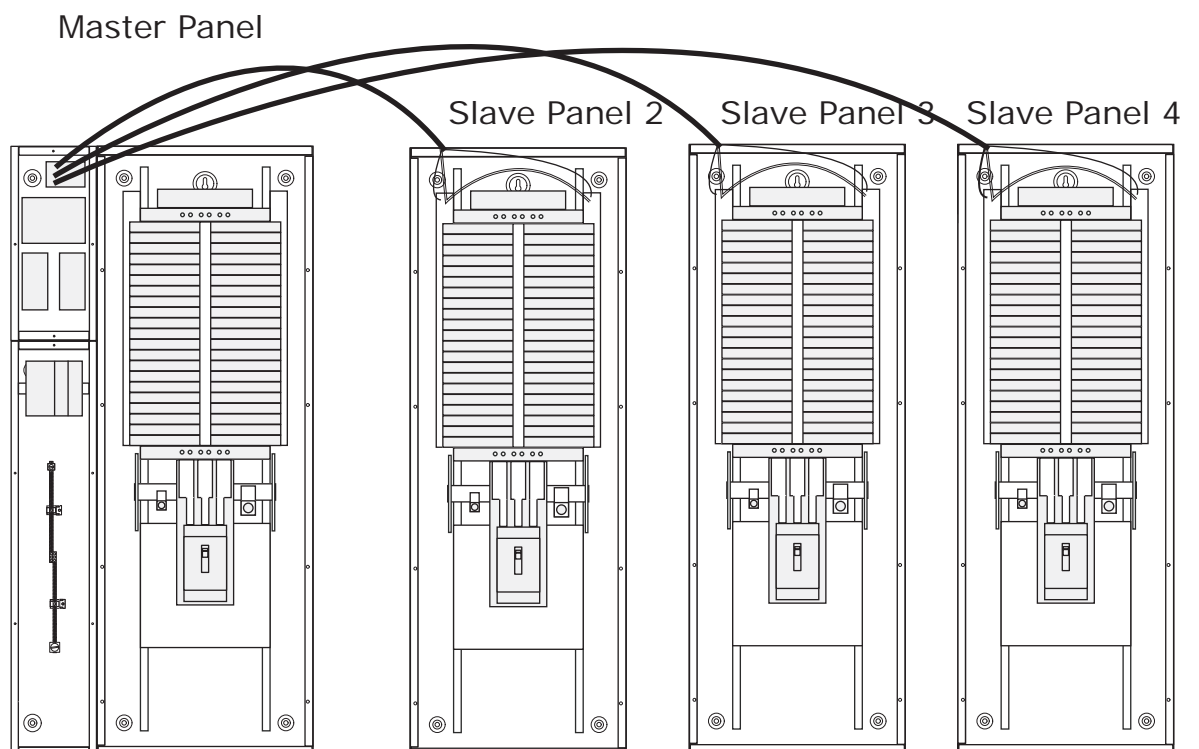

**Figure 4-3: Digital I/O Remote Switch and Sensor Wiring**

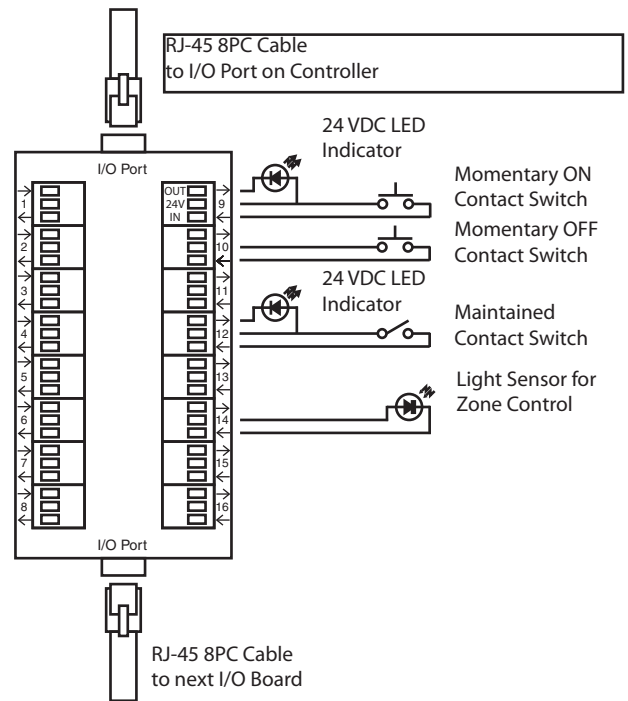

Switches or sensors being used to control either sequenced or grouped zones are to be connected to the Digital I/O three-position spring-clamp headers. Each header can accommodate one input device (switch, sensor, relay) and one output device (indicator) maximum.

The center terminal of each Digital I/O header is used as a 24VDC source. The input terminal is triggered when connected through a remote device to the 24VDC source. The output terminal activates a remote device by pulling down from 24VDC to 0VDC and creating current flow.

To assign both an On and Off function for one zone would require two input terminals and occupy two I/O headers. Six (6) Digital I/O headers are located on the left side of the Controller board. If more connections are required for multiple zone control, additional I/O Expander boards can be added. Each I/O Expander board provides an additional 16 headers for a maximum total of 38 input control sources and output indicators.

**Emergency Shutdown Wiring:**

To connect your fire alarm or emergency management system to the RPC, follow these steps.

1. From the fire alarm unit or latching Emergency Shutoff switch, wire the Normally Open (NO) contacts to the IN and 24V positions of Digital I/O Port #1 on the Controller.
2. If a remote status indicator is used, ensure that the positive terminal is wired to the 24V position and the negative terminal is wired to the OUT position of Digital I/O Port #1.
3. When the Normally Open contacts are closed, the status indicator will immediately light and all breakers that have been selected for E. Shutoff should cycle to OFF.
4. When the contacts are released, the status indicator will extinguish and all breakers that were ON when E. Shutoff was activated should return to the ON state.

See Chapter 5 to configure the software for emergency shutdown.

**Figure 4-4: Emergency shutdown wiring**

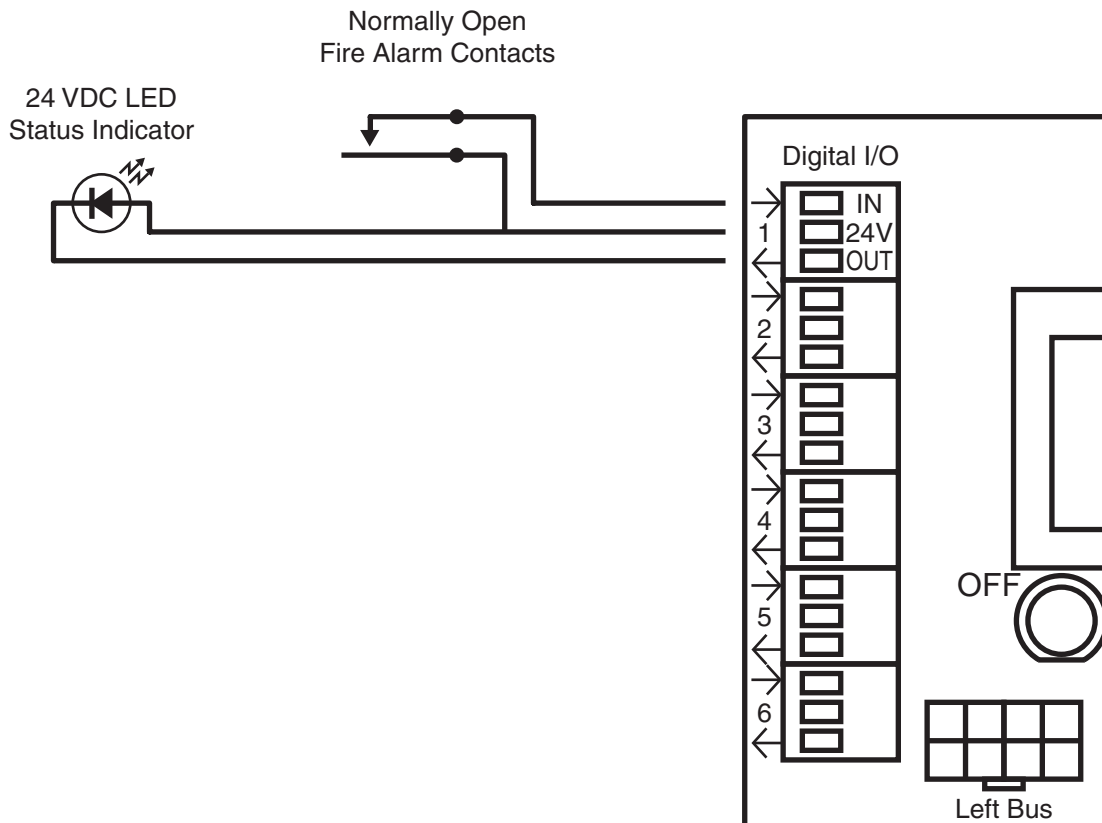

**Emergency Lighting Wiring:**

To connect your fire alarm or emergency management system to the RPC, follow these steps.

1. From the fire alarm unit or latching Emergency Lighting switch, wire the Normally Open (NO) contacts to the IN and 24V positions of Digital I/O Port #6 on the Controller.
2. If a remote status indicator is used, ensure that the positive terminal is wired to the 24V position and the negative terminal is wired to the OUT position of Digital I/O Port #6.
3. When the Normally Open contacts are closed, the status indicator will immediately light and all breakers that have been selected for E. Lighting should cycle to ON.
4. When the contacts are released, the status indicator will extinguish and all breakers that were OFF when E. Lighting was activated should return to the OFF state.

See Chapter 5 to configure the software for emergency lighting.

**Figure 4-5: Emergency Lighting Wiring**

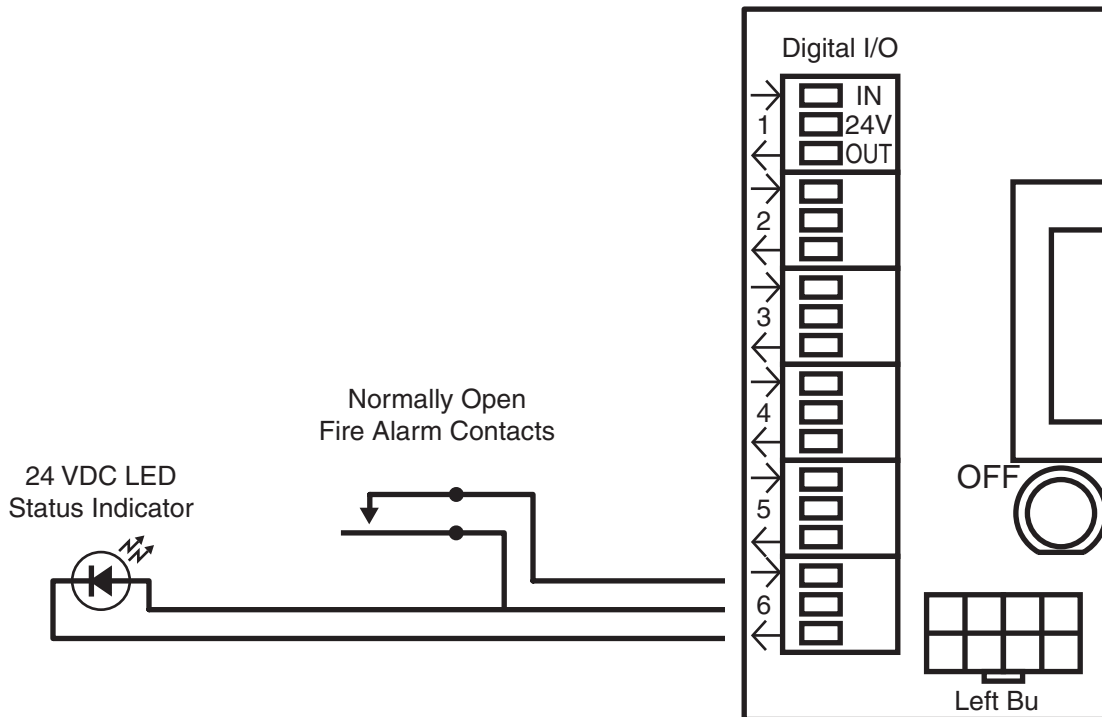
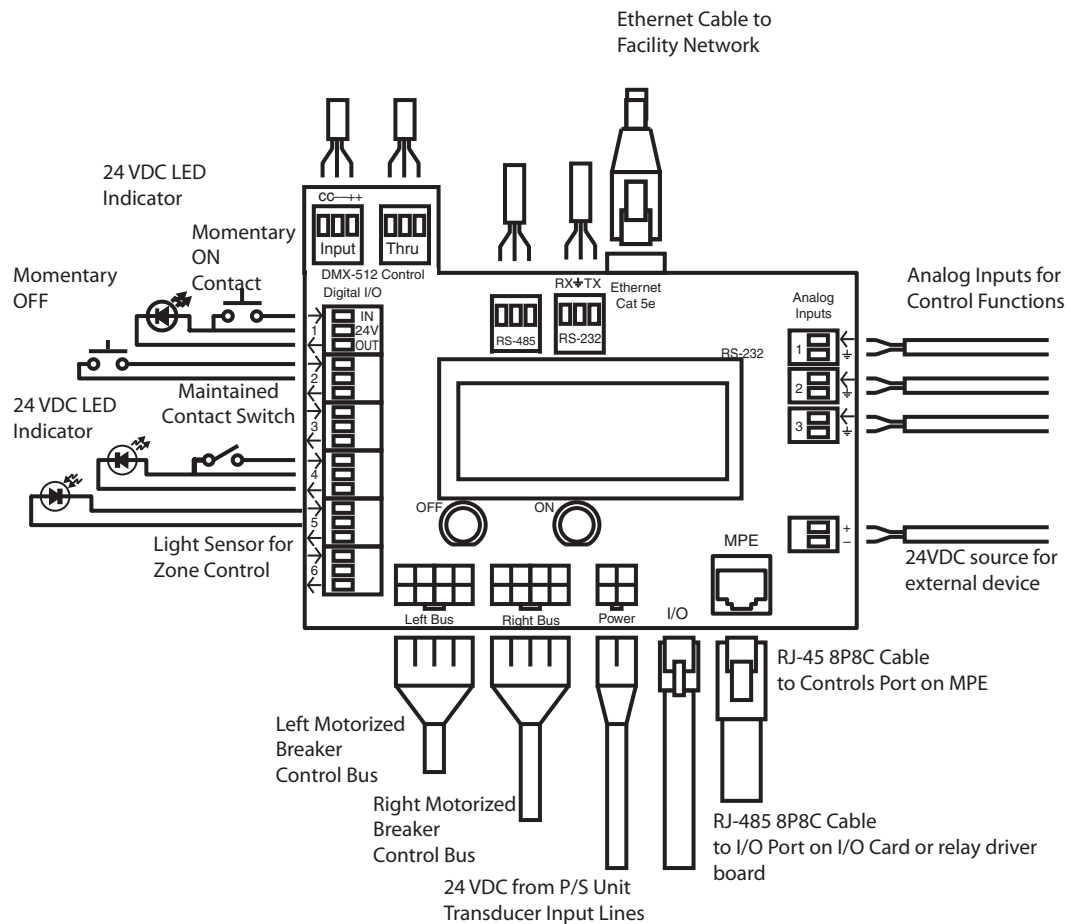



Figure 4-6: Control Wiring

**TCP/IP**

Install and connect a standard Cat. 5e cable from the facility 10/100 network to the Controller Ethernet port.

**sACN**

Install and connect a standard Cat. 5e cable from the facility 10/100 network to the Controller Ethernet port.

**DMX**

If DMX-512 is being used to control the panel, install and connect a shielded pair cable from the DMX source to the Controller DMX Input three-position spring-clamp header. Terminate common, DMX- and DMX+ from left to right in the header. Follow the same wiring guide for the DMX Thru header.

**RS-232**

If RS-232 is being used to control the panel, install and connect a shielded pair cable from the RS-232 source to the Controller RS-232 three-position spring-clamp header. Terminate receive, ground and transmit from left to right in the header.

**RS-485**

RS-485 connector is reserved for use with CM-H current monitoring hardware. See manual for installation and operation instructions.

### Switch Wiring Instructions

The I/O ports on your RPC controller allow for a variety of switch options.

#### LynTec SS-2 Switch Set

Using a standard LynTec SS-2 Switch Set with illuminated ON switch. See Figure 4-6

1. Wire the ON switch to Digital I/O port 2 on the left edge of the Controller board as follows:
  - i. Connect the 24VDC Common (center terminal of the I/O port) to the C pin of the ON switch. Jumper the C pin of the ON switch to the + pin.
  - ii. Connect the Input terminal (arrow pointing towards header) to the NO pin of the ON switch.
  - iii. Connect the Output terminal (arrow pointing away from header) to the – pin of the ON switch.
2. Wire the OFF switch to Digital I/O port 3 on the left edge of the Controller board as follows:
  - i. Connect the 24VDC Common terminal to the C pin of the OFF switch.
  - ii. Connect the Input terminal to the NO pin of the OFF switch

**Figure 4-7**  
**LynTec SS-2 Wiring Diagram**

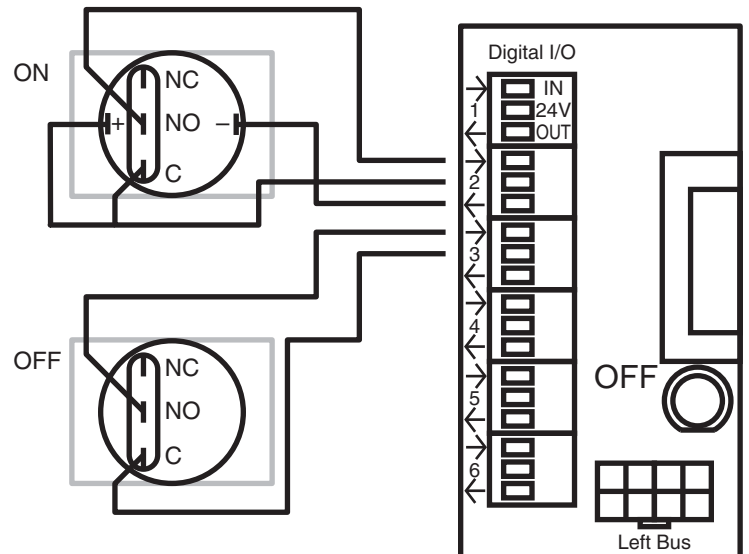

**To configure the Digital I/O port and link it to a zone see Chapter 5.**

## SS-2PL and SS-2LRP Locking Switch Sets

Using a standard LynTec SS-2PL or SS-2 LRP Switch Set with illuminated ON switch. See Figure 4-7

1. Wire the ON switch to Digital I/O port 2 on the left edge of the Controller board as follows:
  - i. Connect the 24VDC Common (center terminal of the I/O port) to the + pin of the ON switch.
  - ii. Connect the + pin on the on switch to the 1 pin on the lock.
  - iii. Connect the Input terminal (arrow pointing towards header) to the NO pin of the ON switch.
  - iv. Connect the Output terminal (arrow pointing away from header) to the – pin of the ON switch.
  - v. Connect the C pin on the ON switch to the 3 pin on the lock.
2. Wire the OFF switch to Digital I/O port 3 on the left edge of the Controller board as follows:
  - iii. Connect the 3 pin on the lock to the C pin on the OFF switch.
  - iv. Connect the Input terminal to the NO pin of the OFF switch

**Figure 4-8**

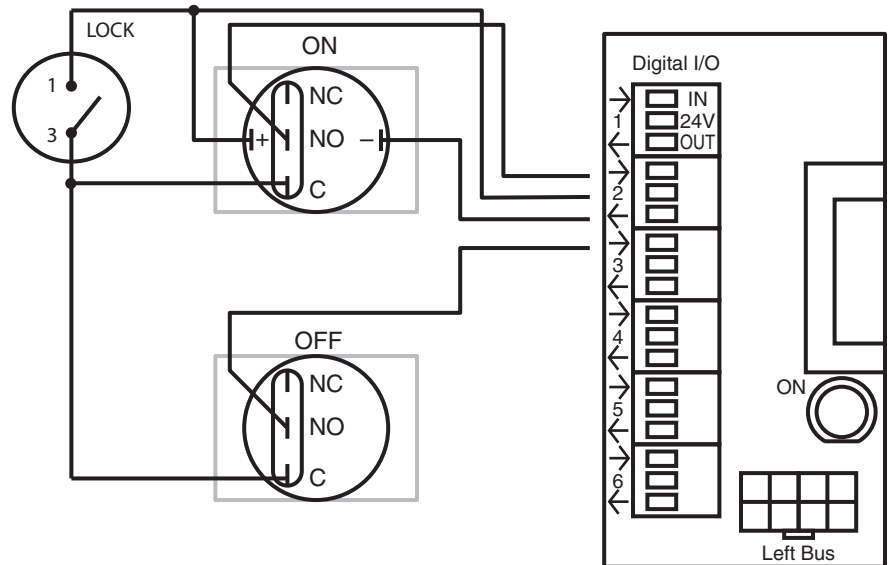

**To configure the Digital I/O port and link it to a zone see Chapter 5.**

**Figure 4-11: Complete RPC Wiring for Motorized Breaker Panels**

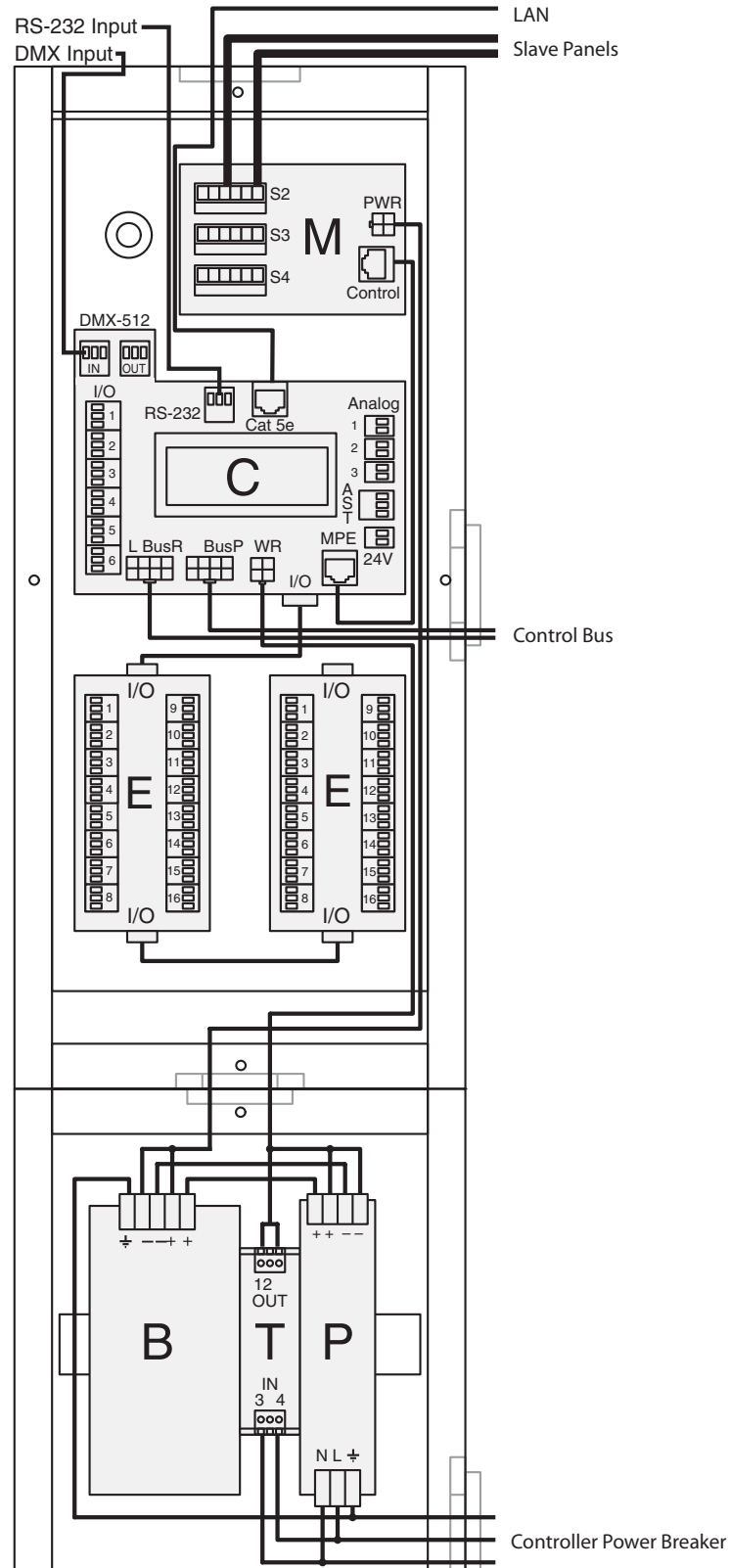

Figure 4-12: RPC Mechanical Drawing

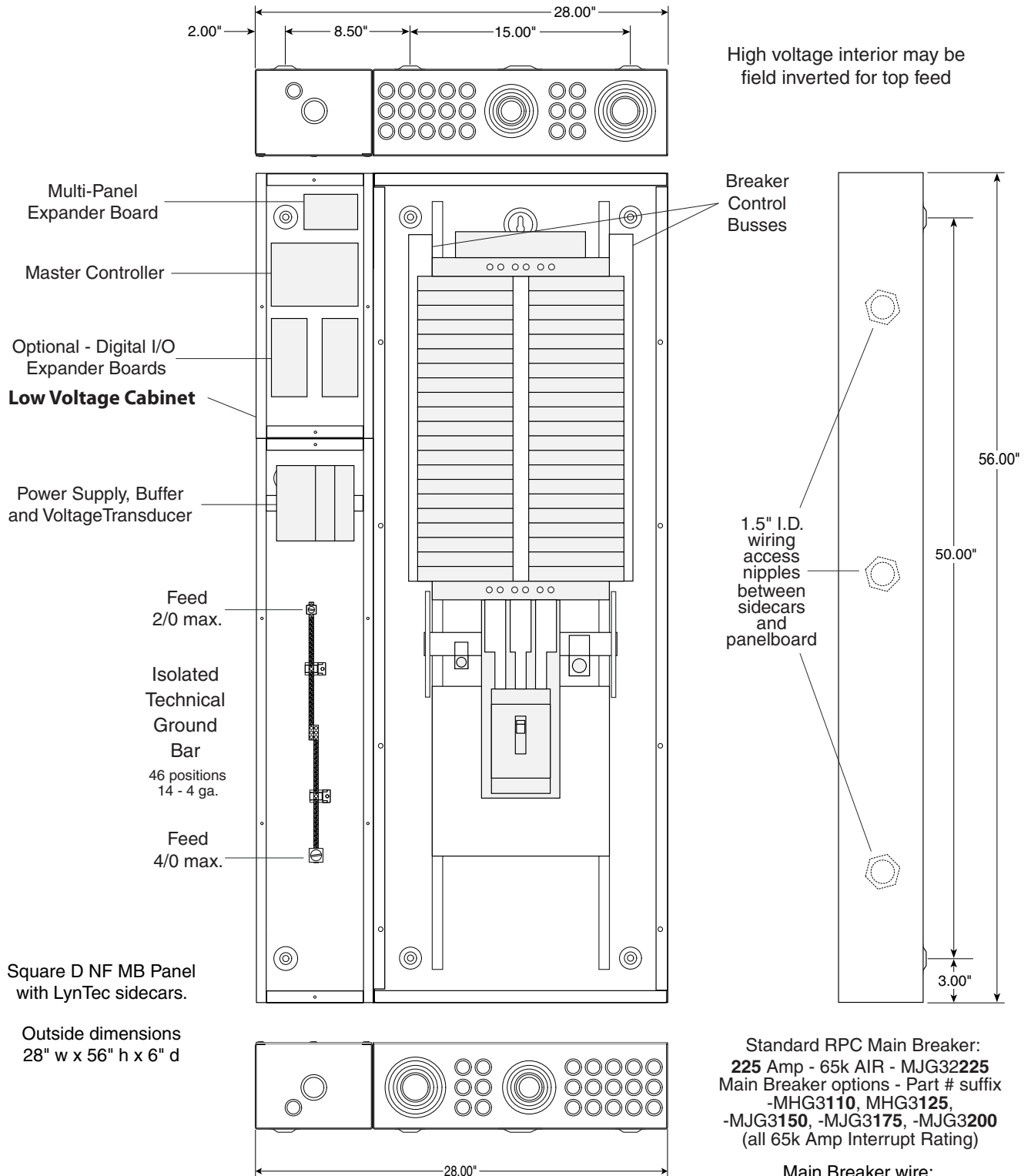
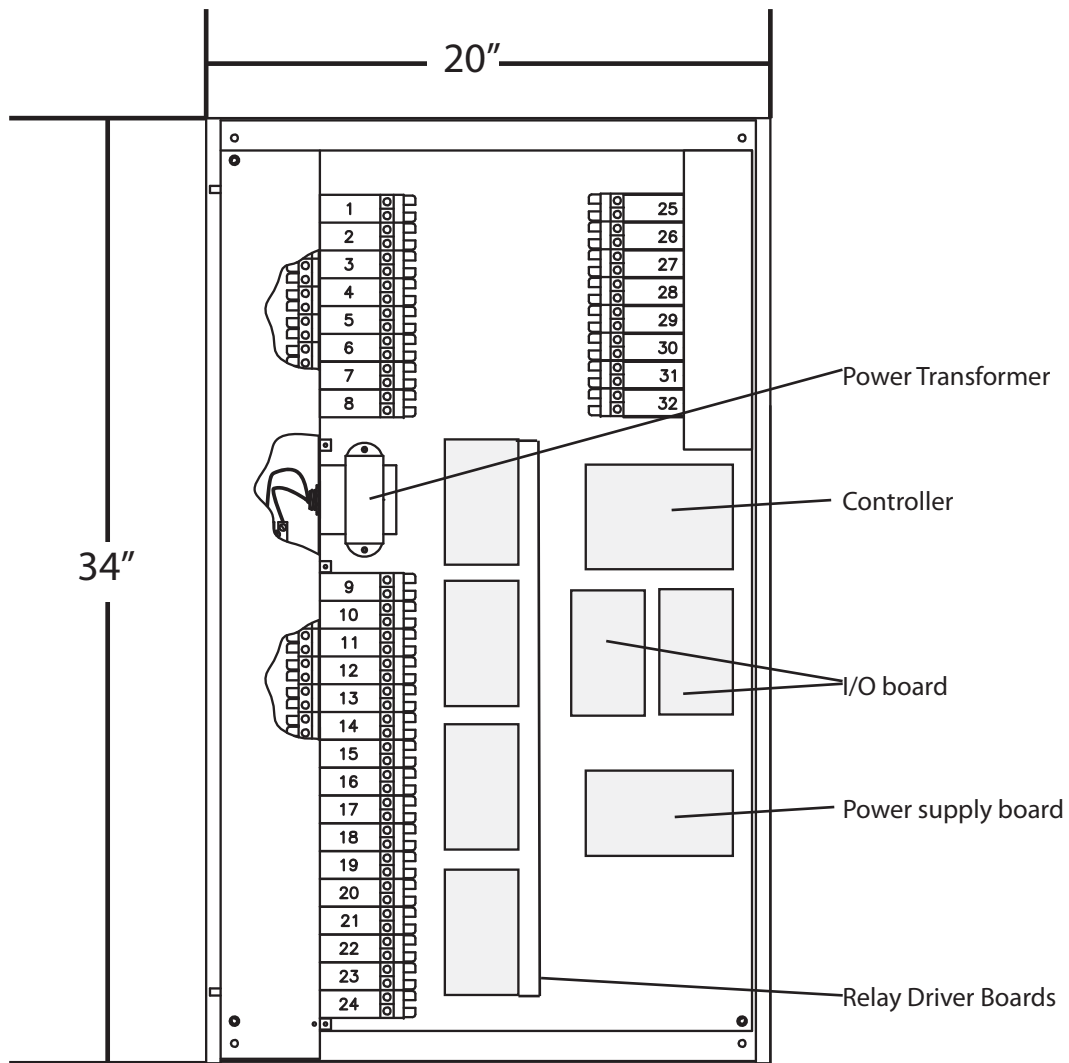

Figure 4-13: RPCR-32 Mechanical Drawing



---

## INITIAL POWER UP PROCEDURE

With panel door open and breakers visible, turn on the panel main breaker and the Controller Power 15 Amp circuit breaker.

The green 'DC OK' LED should illuminate on the Power Supply and the green 'STATUS' LED on the Buffer unit should begin flashing steadily. The Buffer 'STATUS' LED will be constantly lit when the unit has been fully charged.

The Controller LCD display and orange Power LED should illuminate. If installed, the orange Power LED's on the I/O Expander boards and the orange Power LED on the MPE board will illuminate. RPC will "beep" four times.

Connect a computer with an Ethernet port and installed web browser program to the RPC Network connector using the provided crossover cable. Then enter the default IP address for the controller, 192.168.1.250.

## Chapter 5--Control Setup (Web Page)

### OVERVIEW

There are 5 main tabs on your RPC web page. This page will give you a quick overview of the pages and their functions.

### STATUS

The status page allows you to view the current status of the breakers and zones. Zones and individual breakers cannot be manipulated from this page.

### CONTROL

This page allows the user to manipulate individual breakers as well as breaker zones. "All ON/OFF" and "Hurry-Off" commands can also be triggered from this page.

### SETUP

The setup section allows you to setup and use the RPC controller. From this section you can manipulate the network settings, assign breakers to zones, create sequences, activate emergency management features, create schedules and assign contact closures.

### SUPPORT

This page provides contact information for LynTec.

### EVENT LOG

This page provides a log of events.



## Setup

This section will guide you through the process of setting up your RPC Controller. First enter the IP address or NetBios name into your web browser. When the RPC screen pulls up. Select "Setup" and "SetupHome" Tabs.

### SETUP HOME

Figure 5-1--Setup Home

Status	Control	Setup	Support	Event Log	Logout
Setup Home	Network	Panels	Alerts	Contact Closures	
<b>Contact Information</b>					
Serial Number					
Job Name	Lyntec Test Job				
Contractor Name	Price Electrics				
Phone #	800-GET-RPC1				
System Integrator	AVI				
Phone #	800-ADD-CTLR				
<b>Clock Set</b>					
Note: Only changed clock values will be updated.					
Year (00-99)	14				
Month (1-12)	10				
Day (1-31)	21				
Hour (0-23)	14				
Min (0-59)	40				
Sec (0-59)	38				
Day of the Week	Tuesday ▼				
<b>Schedules</b>					
<input type="checkbox"/> Use Schedules					
Update Information					
<b>Printable Pages</b>					
<input type="radio"/> Network Setup <input type="radio"/> Panel Setup <input checked="" type="radio"/> Panel Schedules					Print Pages
<b>Password Reset</b>					
Note: If the root username or password updated successful , you will be prompted for login information before the webpage will reload.					
UserLevel	Super ▼				
Username					
Password					
Repeat Password					
Update Login Info					
<b>Update Web Page Software</b>					
File	Choose File No file chosen				
Upload Web Pages					
<b>Update Firmware</b>					
File	Choose File No file chosen				
Upload Firmware					
<b>Reboot RPC</b>					
Note: New Firmware does not take affect until the RPC has been rebooted.					
Reboot RPC					

To set the username and password for your panel, click the Setup tab. The Setup Home tab should be displayed. The default username displayed should be "admin" and the password fields should be "pw". Enter the desired username in the first field, password (without spaces or symbols) in the second and then retype the password again in the third field. When ready, click the Update Login Info button to save the changes to the controller's memory.

Contact information for service can also be entered on this page. Under the Serial Number field, enter the name and phone number of the installing contractor (Electrician) and the system integrator (A/V Technician) for future reference. Save this information by clicking the Update Information button below the Clock Set portion of the window.

Basic date and time information will be displayed in the Clock Set fields. Verify that the year, month and day are correct. Set the hour to the appropriate time for your time zone and verify that the minute displayed is correct. Save this information by clicking the Update Information button below the Clock Set portion of the window.

Click the radio buttons for any pages to be printed out under the Printable Pages header. To print the Network Setup, Panel Setup or Panel Schedules pages at any time, ensure the desired buttons have been selected and then click the Print Pages button to the right. Please print a copy for your records after setup is complete.

## Network setup

**Figure 5-2--Network Configuration**

Figure 5-2 shows the network configuration portion of the Network setup.

Network Configuration			
Hostname	LYNTECRPC220		
Enable DHCP	<input checked="" type="checkbox"/> <i>If checked, DHCP is enabled. This module will automatically be assigned an IP, Subnet and Gateway address.</i>		
IP Address:	192.168.1.111	DNS1:	192.168.1.254
Subnet Mask:	255.255.255.0	DNS2:	0.0.0.0
Gateway Address:	192.168.1.254	MAC Address:	00:23:50:01:02:18

This screen shows the current network values. If DHCP is enabled then the fields will be greyed out. It is recommended that the user consult with the network administrator before changing these values.

The IP, Subnet and Gateway addresses are only used in the following situations:

- When DHCP is disabled
- When DHCP is enabled, but there is no DHCP server available on the network
- When the RPC provides DHCP addresses

If DHCP is enabled and available on the network, all these values will be obtained from the DHCP server.

If DHCP is disabled and a static address is used, save changes and then press "Reset RPC" to apply changes.

Figure 5-3: Interface options

Parameters	
Port Type	<input type="radio"/> RS232      Baud Rate: 115200 ▾ OFF threshold: 63 (0-255) or 24 % (valid range: 0 to 190) ON threshold: 191 (0-255) or 74 % (valid range: 64 to 255)
	<input type="radio"/> DMX512      (valid range: 1 to 512)
	<input checked="" type="checkbox"/> Set 1: 1st Address 1 (default)      Loss of Signal Options <input checked="" type="radio"/> No Action <input type="radio"/> ON <input type="radio"/> OFF
	<input checked="" type="checkbox"/> Set 2: 1st Address 1 <input checked="" type="radio"/> No Action <input type="radio"/> ON <input type="radio"/> OFF
	<input checked="" type="checkbox"/> Set 3: 1st Address 1 <input checked="" type="radio"/> No Action <input type="radio"/> ON <input type="radio"/> OFF
	<input checked="" type="checkbox"/> Set 4: 1st Address 1 <input checked="" type="radio"/> No Action <input type="radio"/> ON <input type="radio"/> OFF
	RDM <input type="checkbox"/> (E1.20) Remote Device Management
	<input checked="" type="radio"/> sACN (E1.31)      (valid range: 1 to 63999)      (1 to 512)
	<input checked="" type="checkbox"/> Universe 1: 1 (default) 1st Address: 97      Loss of Signal Options <input checked="" type="radio"/> No Action <input type="radio"/> ON <input type="radio"/> OFF
	<input checked="" type="checkbox"/> Universe 2: 2      1st Address: 481 <input checked="" type="radio"/> No Action <input type="radio"/> ON <input type="radio"/> OFF
<input type="checkbox"/> Universe 3: 1      1st Address: 1 <input checked="" type="radio"/> No Action <input type="radio"/> ON <input type="radio"/> OFF	
<input type="checkbox"/> Universe 4: 1      1st Address: 255 <input checked="" type="radio"/> No Action <input type="radio"/> ON <input type="radio"/> OFF	
RDMnet <input type="checkbox"/> (E1.33) Remote Device Management	
Save Changes	<input type="button" value="Save"/>
Reboot RPC	<input type="button" value="Reboot RPC"/>

## Port Type

The port type section is used to select the preferred communication protocol. The controller defaults to Ethernet (TCP/IP) for setup but can be controlled in conjunction with RS-232, sACN or DMX-512 protocols.

## RS-232

For RS-232 operation use the following steps:

Select a baud rate in the dropdown box from 300 to 115,200 Baud. The default is 9600. The data structure is set at 8 Data bits, 1 Stop bit and No Parity bit (8,1,N). Then set the ON and OFF thresholds in either the 0-255 range or the percentage range.

## DMX

For DMX operation use the following steps:

The RPC allows up to four different sets of DMX starting addresses within a single universe.

In the first set, enter the first individual breaker address. All motorized breakers need to be assigned addresses manually. Do this by clicking on each breaker in the order you would like them to be addressed. If you need to skip an address or group of addresses, simply create a new zone and enter the desired starting address. If you would like the RPC to automatically assign breakers to consecutive addresses, you may change that in the "Panels" tab.

## Streaming ACN E1.31

For sACN operation use the following steps:

The RPC allows up to four different universes with sACN operation.

First, assign a number to the universe.

In the first set, enter the first individual breaker address. All motorized breakers need to be assigned addresses manually. Do this by clicking on each breaker in the order you would like them to be addressed. If you need to skip an address or group of addresses, simply create a new zone and enter the desired starting address. If you would like the RPC to automatically assign breakers to consecutive addresses, you may change that in the "Panels" tab.

Please note that selecting sACN/DMX control for a breaker or zone, will disable web browser or contact closure control for that breaker/zone. Although, breaker/zone status may still be monitored by web browser or smartphone.

DMX and sACN are exclusive and cannot be used on the same controller at the same time. Either can be used to control breakers in zones while other zones are controlled by RS-232, IP commands or contact closures.

## Panel Setup

This section explains how to setup your panel and motorized breakers for remote operation.

### BREAKER SETUP

To setup breakers, follow these steps:

1. Under Setup, go to the Panels tab.
2. After breakers are installed by a qualified electrician, click the "Scan Breakers" button. Motorized breakers are represented in white, unmotorized breakers or blank spaces are represented in gray.

**Figure 5-4**

Panel 1		Panel 2		Panel 3		Panel 4	
1		22	1		22	1	
2		23	2		23	2	
3		24	3		24	3	
4		25	4		25	4	
5		26	5		26	5	
6		27	6		27	6	
7		28	7		28	7	
8		29	8		29	8	
9		30	9		30	9	
10		31	10		31	10	
11		32	11		32	11	
12		33	12		33	12	
13		34	13		34	13	
14		35	14		35	14	
15		36	15		36	15	
16		37	16		37	16	
17		38	17		38	17	
18		39	18		39	18	
19		40	19		40	19	
20		41	20		41	20	
21		42	21		42	21	

3. If panel configurations are correct, click "Accept Changes"

4. Assign names to the breakers. (Figure 5-5)

**Figure 5-5**

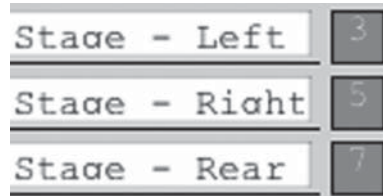

## ZONE SETUP

Breakers can be controlled individually or arranged into zones. Breakers in zones can be toggled at 25 ms intervals (Grouped Operation), at variable intervals (Sequenced Operation), or via DMX or sACN.

To setup a Zone follow these steps:

1. Choose which zone you would like to edit. (Figure 5-6)

**Figure 5-6**

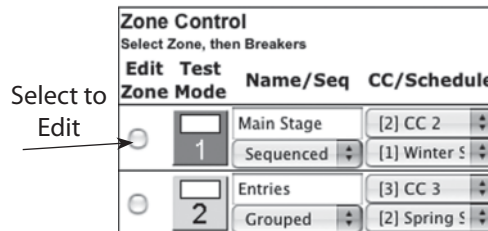

2. Name the Zone. (Figure 5-7)
3. Choose Grouped, Sequenced, DMX or sACN operation. Note: DMX and sACN may not be used within the same RPC (Figure 5-7)

Figure 5-7

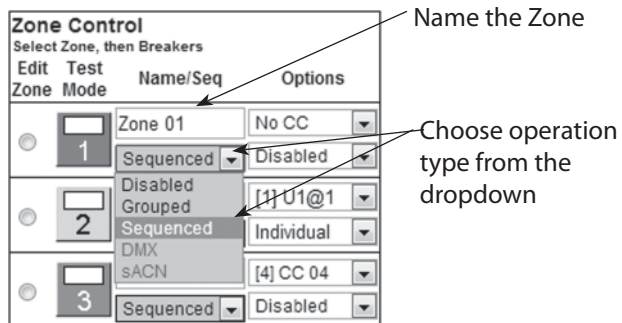

4. If using DMX or sACN operation, select the address set (Figure 5-8) or universe (Figure 5-9) from the dropdown.

Figure 5-8

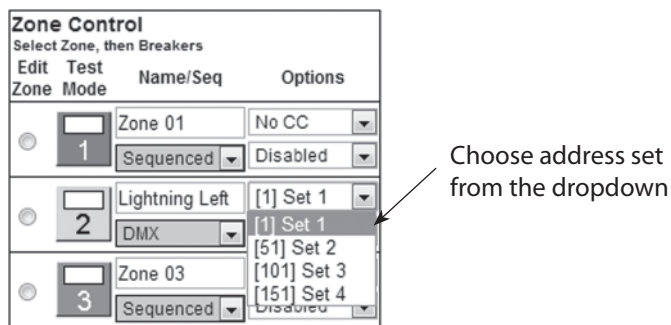
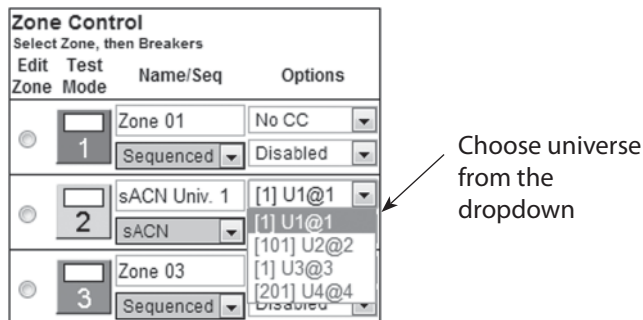

Figure 5-9



5. Select a breaker to add to the zone by clicking on the breaker you want to add. Only motorized breakers (indicated in green) may be added to zones. (Figure 5-10)

**Figure 5-10**



6. Select the position of the breaker in the zone. This set the order in which they turn on and off. Or in the case of DMX or sACN, the address order. (Figure 5-11). Note: DMX and sACN zones default to individual addressing. If you choose "All Available" the entire panel or panels will change to DMX or sACN.
7. For sequenced operation, select a delay time from the dropdown. Breakers in grouped zones toggle in 25ms intervals. (Figure 5-11) Delay time is the amount of time after a breaker changes state, before the new breaker in sequence changes state.

**Figure 5-11**

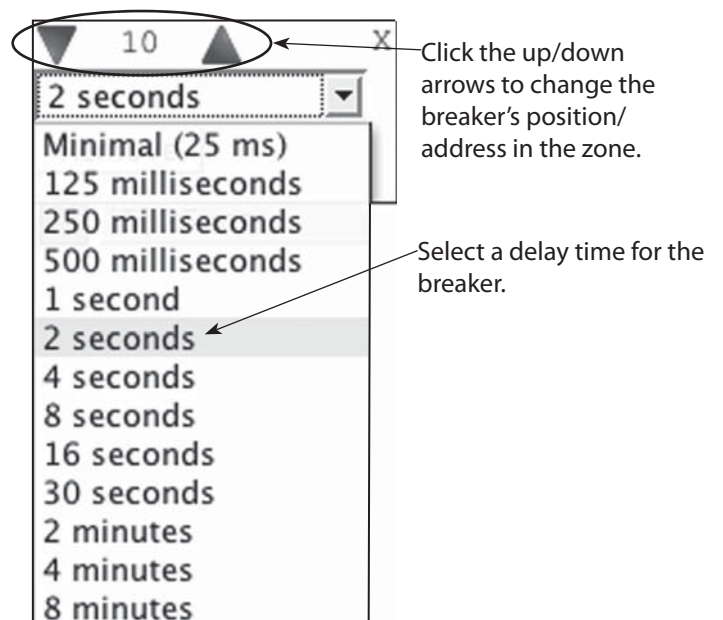



8. Click the "Close" button when finished to save. Or, click "Remove" to remove the breaker from the zone.
9. When finished adding breakers to the zone, click the "Test Mode" (Figure 5-12) button to do a blind test (breakers will not actually toggle). Please note that delay times larger than one second are reduced to one second in Test Mode for expediency.

Figure 5-12

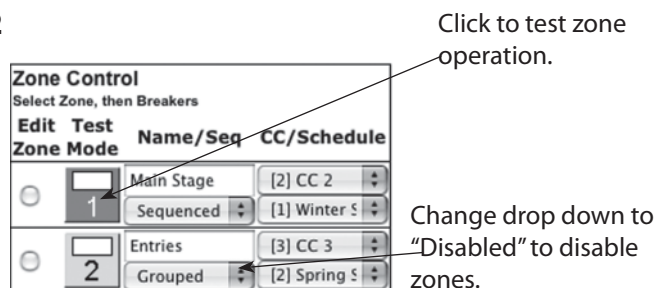

10. Disable zones that are not in use so they do not appear in the status and control pages (Figure 5-12).
11. Click "Save Changes" (Figure 5-13) to save zone information when finished.

**Figure 5-13**



## GLOBAL PREFERENCES SETUP

### Labeling

This section guides you through the setup process for the many features and preferences in your RPC system.

In addition to labeling breakers, each panel in your RPC system can be named (up to 16 characters) and the changes dated (Figure 5-14). For multi-panel systems, scroll down to see additional panels.

**Figure 5-14**

<b>Panel:</b>	Panel A
<b>Date:</b>	18-Jul-08

### Numbering and addressing

The RPC system allows the user to choose top/bottom panel numbering or left/right panel numbering. (Figure 5-15) It also allows you to select the direction for addressing (DMX only).

**Figure 5-15**

**Circuit Numbering**

Left-Right

Top-Bottom

**Addressing Scheme**

Left-Right

Top-Bottom

---

Every Circuit

Installed Breakers

## Global Control Preferences

The following features can be selected for additional system flexibility

Figure 5-16

The image shows a vertical list of control preferences. Each item has a checkbox on the left and a dark grey button on the right. Below each button are radio button options for 'Enable Recovery' and 'Disable Recovery'.

- All Breakers On
- All Breakers Off
- Hurry-Off
- E. Shutoff
  - Enable Recovery
  - Disable Recovery
- E. Lighting
  - Enable Recovery
  - Disable Recovery
- Audio
- Brownout
  - Enable Recovery
  - Disable Recovery

Table 5-1

All Breakers On/Off	Turns all the breakers on or off by order of zone and sequence
Hurry-Off	Turns breakers off rapidly without sequencing
E. Shutoff	Turns selected breakers off when external contacts or emergency management system activates (uses I/O CC#1)
E. Lighting	Turns selected breakers on when external contacts or emergency management system activates (uses I/O CC#6)
Audio	Activates optional audio sensing timer.
Brownout	Turns selected breakers off in the event of a brownout. Sequences circuits back on when voltage has stabilized for 4 seconds (optional on RPCR)

### Selecting breakers for Emergency Shutdown, Emergency Lighting or Brownout

Figure 5-17

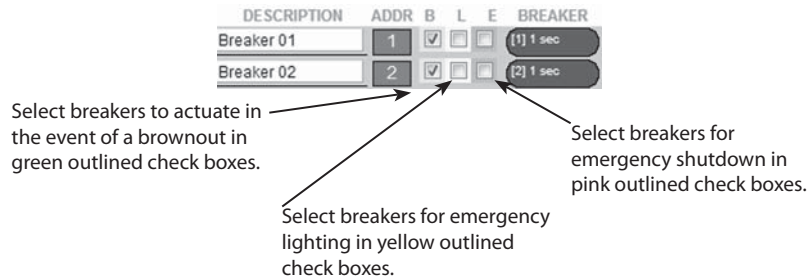

Select breakers to actuate in the event of a brownout by checking the green box next to the breaker. Select breakers to turn on in the event of a fire or other emergency by checking the yellow box next to the breaker. Select breakers to turn off in the event of a fire or other emergency by checking the red box next to the breaker. The status of unchecked breakers will remain unaffected.

### Brownout Thresholds (optional)

Figure 5-18

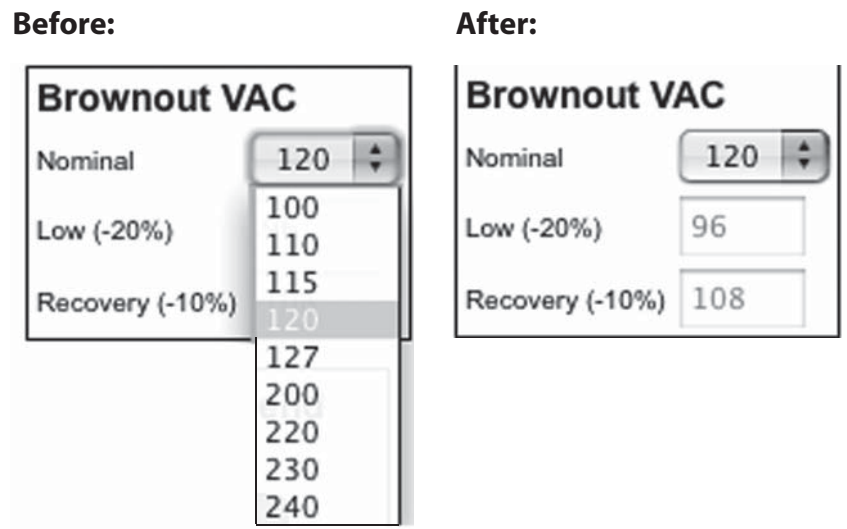

If the brownout feature has been selected, the nominal AC Voltage should be set for proper operation. Click the pull down menu in the brownout VAC box and select the nominal operation voltage for the panel (100-240 VAC) The brownout thresholds will automatically adjust for shutoff at nominal -20% and recovery at nominal -10%..

## Schedule Setup

Follow these steps to set a schedule (not compatible with DMX or sACN).

1. Enable Schedules in Setup Home tab
2. Rename each schedule as desired
3. Assign weekday (M-F) on and off times by clicking on time and off time buttons, using pull-down menu and clicking the pick button to select.
4. Assign weekend (S-S) on and off times by clicking on time and off time buttons, using pull-down menu and clicking the pick button to select.
5. Enable each schedule by clicking the checkbox for that line.
6. Click the Save Changes button at the top of the page to save

Figure 5-19

Schedule Name	Enabled	Monday - Friday		Weekend	
		On Time	Off Time	On Time	Off Time
Winter Schedule	<input checked="" type="checkbox"/>	On Time: 10:15 am	Off Time: 5:15 pm	On Time: 10:00 am	Off Time: 3:15 pm
Spring Schedule	<input checked="" type="checkbox"/>	On Time: 10:15 am	Off Time: 5:15 pm	On Time: 10:00 am	Off Time: 3:15 pm
Summer Schedule	<input checked="" type="checkbox"/>	On Time: 10:15 am	Off Time: 5:15 pm	On Time: 10:00 am	Off Time: 3:15 pm
Fall Schedule	<input checked="" type="checkbox"/>	On Time: 10:15 am	Off Time: 5:15 pm	On Time: 10:00 am	Off Time: 3:15 pm

## Assigning Schedules to Zones

To assign a schedule to a zone in the "Panel" screen:

1. Select the desired zone from the drop down box.
2. Save changes.

Figure 5-20

Zone Mode	Name/Seq	CC/Schedule
1	Main Stage Sequenced	[2] CC 2 [1] Winter
2	Entries Grouped	No Schedule
3	Sound System Sequenced	[1] Winter Schedule [2] Spring Schedule [3] Summer Schedule [4] Fall Schedule [5] Summer [6]

### Contact Closure Setup

Configure the digital I/O port and link it to a zone as follows:

Note: If the Emergency Shutoff feature is selected, the first position in the Onboard field (on the Controller) is automatically assigned to that.

1. Rename each contact closure as desired
2. Select contact closure action type
3. Use CC Module 1 and CC Module 2 only if I/O Expander boards are installed.
4. Save Changes

Figure 5-21

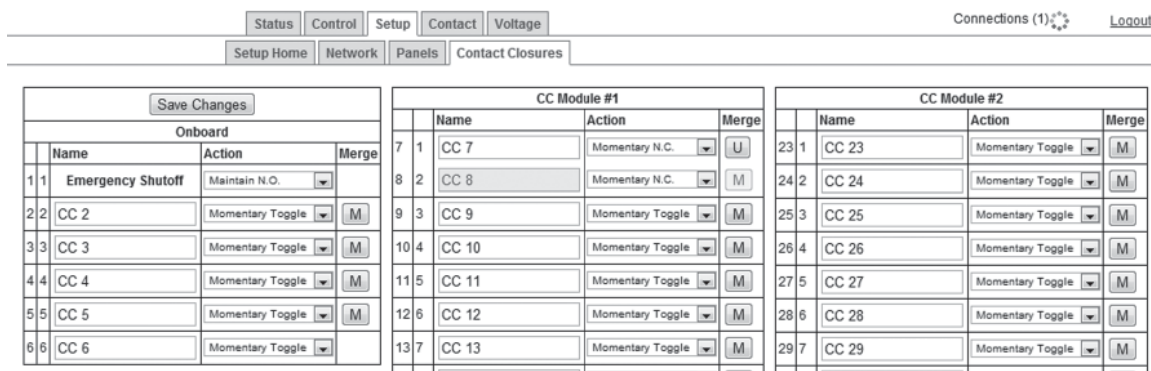

### Assigning Contact Closures to Zones

To assign a contact closure to a zone in the "Panel" screen:

1. Select the desired zone from the drop down box.
2. Save changes.

Figure 5-22

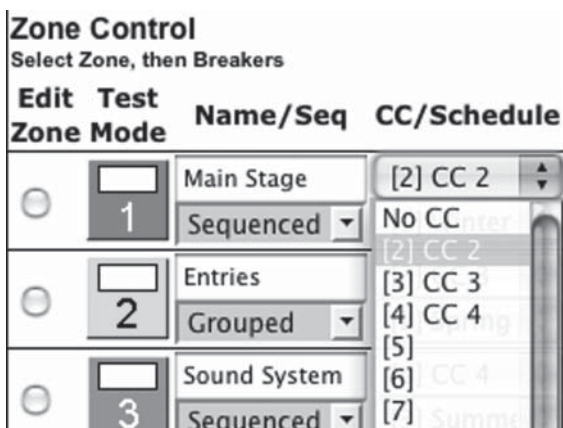

---

**Individual Momentary Contact ON and OFF Pushbuttons**

Using a standard LynTec SS-2 Switch Set with illuminated ON switch or two illuminated pushbuttons:

Configure the Digital I/O port and link it to a zone as follows:

1. Follow the previous instructions for naming the contact closure and setting closure type.
2. Click the M button at the right side of the first of the two ports used. The name box and M button in the second port should turn gray and the Action selections should default to Momentary NO. (normally open)
3. Ensure that both of the Action selections for both ports are set to Momentary NO.
4. Enter a name in the text field of the CC used that is indicative of the zone it will control.
5. Click the "Save Changes" button at the top of the Onboard I/O box.
6. Follow the previous instructions for assigning a contact closure to a zone, selecting the merged ports.
7. Click the Save Changes button in the upper left corner of the Panels page.

Verify proper operation of your Switch Set:

1. Press the ON switch. Breakers in the selected zone should immediately begin actuating.
2. The ON indicator should flash steadily until all of the breakers are in the on state.
3. When the zone has completed, the ON indicator should remain constantly lit.
4. Press the OFF switch. Breakers in the selected zone should immediately begin actuating.
5. The ON indicator should flash steadily until all of the breakers are in the off state.
6. When the zone has completed, the ON indicator should remain constantly dark. Note: When using two illuminate pushbuttons the OFF indicator will remain constantly lit when the zone has completed. (OFF indicator will extinguish immediately when ON is pressed again.)

## I/OR Setup

The I/OR board combines the input function of the I/O board with output devices (either low-voltage SPDT relays or high-current transistors) to control external devices.

In the contact closure setup page the first eight contacts in the I/OR Module are standard I/O ports. Configure the digital I/O ports and link it to a zone as described on the previous page.

The remaining contacts (under the heading "Trigger Controls" are the outputs (relays, transistors, or a combination of both)

Configure the Trigger Controls as follows:

1. Rename each contact closure as desired
2. If desired, merge a pair of outputs. Merged outputs act as a pair of momentary normally open pulsed outputs (for example, the merged outputs would mimic the SS-2 switch set when controlling a PDS-10). Unmerged outputs act as individual maintained normally open toggle switches.
3. If outputs are merged, select a pulse rate length of 50ms-500ms from the dropdown.
4. Save Changes

Figure 5-23

				Status	Control	Setup	Support	Event Log	Logout	
				Setup Home	Network	Panels	Alerts	Contact Closures		
Save Changes										
Onboard				IO Module #1					IOR Module #2	
Name	Action	Merge		Name	Action	Merge	Name	Action	Merge	
11 Emergency Shutoff	Maintain N.O.		7 1 CC 07	Momentary Toggle	M	23 1 CC 17	Momentary Toggle	M		
22 CC 02	Momentary N.O.	U	8 2 CC 08	Momentary Toggle	M	24 2 CC 18	Momentary Toggle	M		
33 CC 03	Momentary N.O.	M	9 3 CC 09	Momentary Toggle	M	25 3 CC 19	Momentary Toggle	M		
44 CC 04	Momentary Toggle	M	10 4 CC 0A	Momentary Toggle	M	26 4 CC 1A	Momentary Toggle	M		
55 CC 05	Momentary Toggle	M	11 5 CC 0B	Momentary Toggle	M	27 5 CC 1B	Momentary Toggle	M		
66 CC 06	Momentary Toggle		12 6 CC 0C	Momentary Toggle	M	28 6 CC 1C	Momentary Toggle	M		
			13 7 CC 0D	Momentary Toggle	M	29 7 CC 1D	Momentary Toggle	M		
			14 8 CC 0E	Momentary Toggle	M	30 8 CC 1E	Momentary Toggle			
			15 9 CC 0F	Momentary Toggle	M	Trigger Controls				
			16 10 CC 10	Momentary Toggle	M	31 1 CC 1F	Momentary 250ms	U		
			17 11 CC 11	Momentary Toggle	M	32 2 CC 20	Momentary 250ms	M		
			18 12 CC 12	Momentary Toggle	M	33 3 CC 21	Momentary 250ms	U		
			19 13 CC 13	Momentary Toggle	M	34 4 CC 22	Momentary 250ms	M		
			20 14 CC 14	Momentary Toggle	M	35 5 CC 23	Maintain N.O.	M		
			21 15 CC 15	Momentary Toggle	M	36 6 CC 24	Maintain N.O.			
			22 16 CC 16	Momentary Toggle		37 7 CC 25	Momentary 250ms	U		
						38 8 CC 26	Momentary 250ms	M		



## Email Alert Setup

Follow these steps to set an email alert

1. Go to Setup Alerts tab
2. Enter email addresses.
3. Select alert types (tripped breaker, BO/EO/EL, On Recovery and/or Temperature)
4. If using Temperature alerts, enter the temperature threshold.

Figure 5-24

Email Alerts							
Enter the alert contact email where alert messages should be sent							
	Enter email address(es)	Breaker Trip	BO/EO/EL	On Recovery	Temp	Current Monitoring Only:	
						Branch Overcurrent	Phase Loss
Alert Contact 1:	<input type="text" value="dan@lyntec.com"/>	<input checked="" type="checkbox"/>	<input type="checkbox"/>	<input type="checkbox"/>	<input type="checkbox"/>	<input type="checkbox"/>	<input type="checkbox"/>
Alert Contact 2:	<input type="text"/>	<input type="checkbox"/>	<input type="checkbox"/>	<input type="checkbox"/>	<input type="checkbox"/>	<input type="checkbox"/>	<input type="checkbox"/>
Alert Contact 3:	<input type="text"/>	<input type="checkbox"/>	<input type="checkbox"/>	<input type="checkbox"/>	<input type="checkbox"/>	<input type="checkbox"/>	<input type="checkbox"/>
Alert Contact 4:	<input type="text"/>	<input type="checkbox"/>	<input type="checkbox"/>	<input type="checkbox"/>	<input type="checkbox"/>	<input type="checkbox"/>	<input type="checkbox"/>
Alert Contact 5:	<input type="text"/>	<input type="checkbox"/>	<input type="checkbox"/>	<input type="checkbox"/>	<input type="checkbox"/>	<input type="checkbox"/>	<input type="checkbox"/>
Repeats:	<input type="radio"/> Hourly <input type="radio"/> Daily <input type="radio"/> Weekly				> 150 °F	> 15 A	< 85 V
Ends:	<input type="radio"/> Never <input type="radio"/> After 2 Emails						
<small>If your firewall settings prevents alert messages from being sent by the embedded SMTP server, or if your ISP blocks SMTP port 25, enter a remote SMTP server that alert email messages can be routed through. Some SMTP servers will reject non-fully qualified hostnames, so you may need to change the hostname on this device to FQDN format, e.e. use myhost.domain.com instead of myhost.</small>							
SMTP server:	<input type="text" value="mail.lyntec.com"/>	Port:	<input type="text" value="25"/>				
	<input type="checkbox"/> Use SSL (usually port 465)						
User:	<input type="text" value="rpc_v2@lyntec.com"/>	Optional					
Password:	<input type="text" value="dan321"/>	Optional					
Message:	<input type="text" value="Alert message from RPC Panel"/>						
<input type="button" value="Send Test Message"/>							

# Chapter Six: Operating your RPC

Figure 6-1

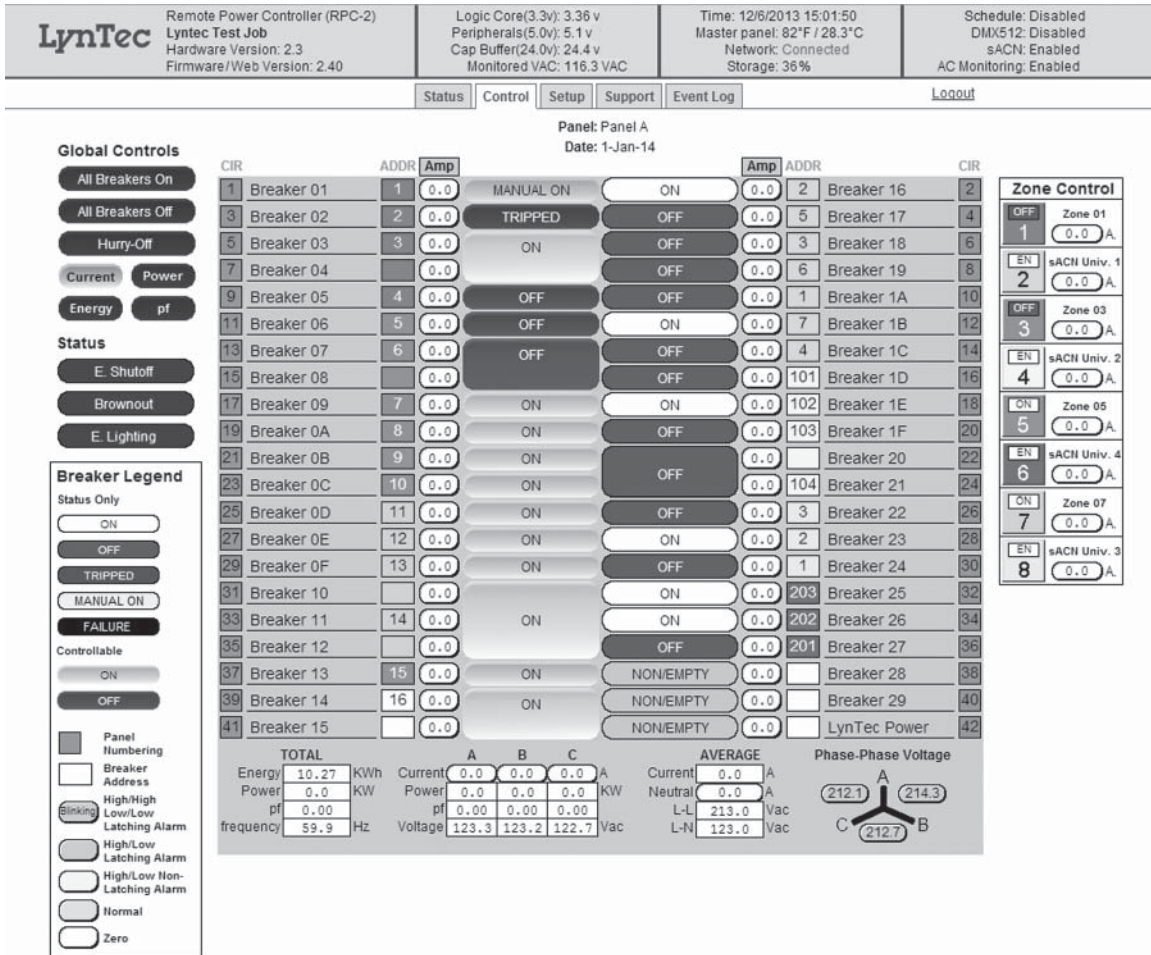

### Using the built-in web page

To operate the RPC using the built in web page, select the control tab from the top of the page. Once on the CONTROL page, simply click each breaker for individual control. Or, click a zone for zone control. "All Breakers ON" and "All breakers OFF" commands can also be executed from this page.

### Using a secondary controller

For DMX and sACN follow the manufacturer's instructions using the DMX addresses entered in the NETWORK page ( see page 16).

RS-232 and TCP/IP schemes are in Appendix B (page 38).

# Appendix A--RPC Quick Start Guides

## RPC to RPS Wiring Instructions

Figure A-1

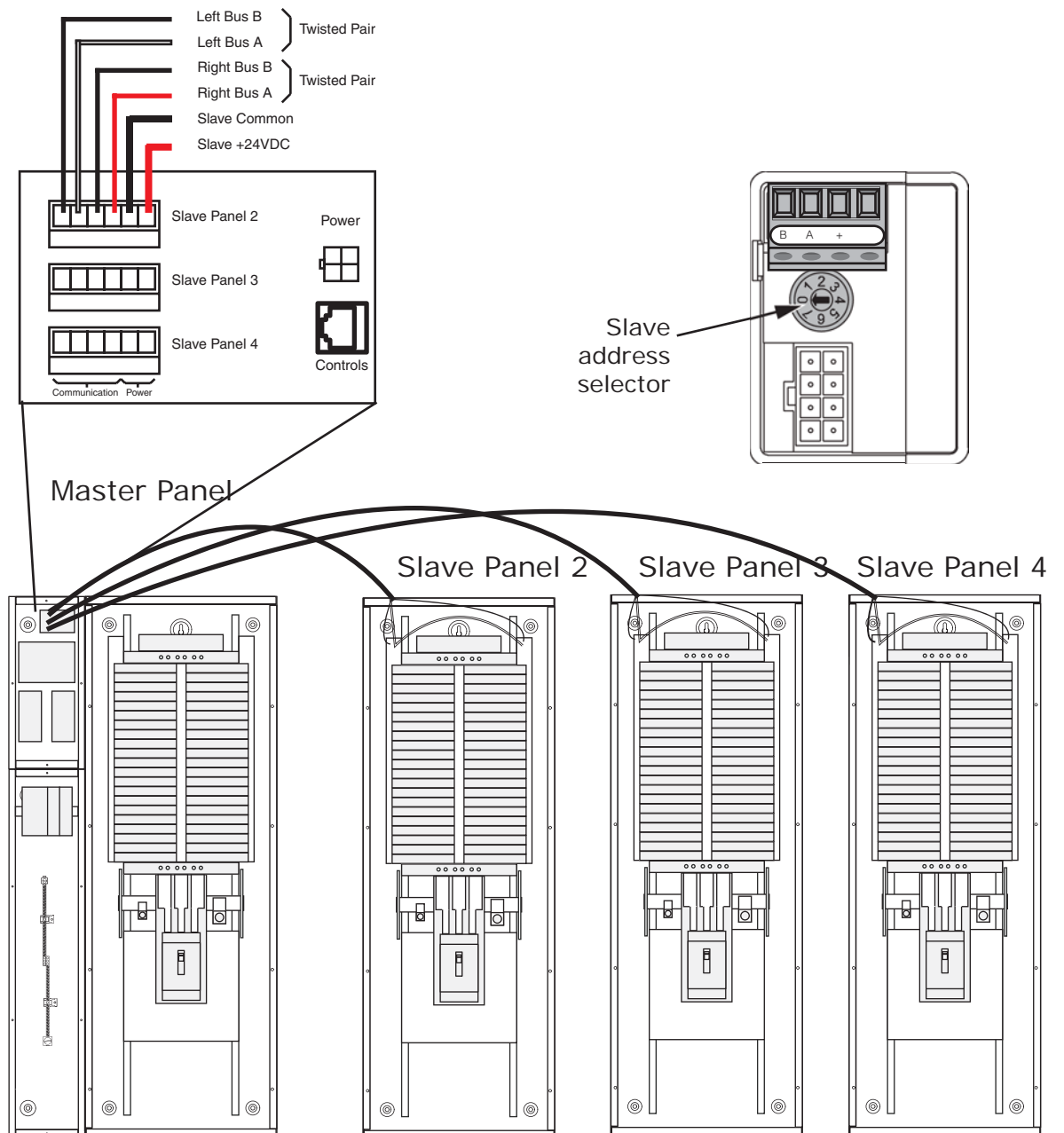

1. If RPS Slave panels are being used in conjunction with an RPC Master panel, install and connect one 18 AWG six (6) conductor (Belden 27600 A or equivalent) or two 18-24 AWG twisted pairs for data and one 16-18 AWG for power per RPS unit. Terminate the Left Bus B, Left Bus A, Right Bus B, Right Bus A, Common (-) and 24VDC (+) in the screw-terminal header for that RPS (Slave Panel 2 – 4) from left to right.
  
2. At the RPS Slave panels, strip the cable sheath back approximately 20 inches. Cut the conductors for Left Bus B, Left Bus A, – and + down to approximately 4 inches and terminate them in the Left Bus screw-terminal header from left to right. Terminate the remaining two conductors in the Right Bus B and Right Bus A positions of the Right Bus screw-terminal header.
  
3. Using two cut lengths of 18 AWG wire, install jumpers from Left Bus – and + to Right Bus – and +. Right Bus will not operate without these jumpers installed to provide 24VDC power and common.
  
4. Set the slave address selectors as follows:

**Table A-1**

	<b>Left Control Bus</b>	<b>Right Control Bus</b>
<b>Panel #2</b>	<b>2</b>	<b>3</b>
<b>Panel #3</b>	<b>4</b>	<b>5</b>
<b>Panel #4</b>	<b>6</b>	<b>7</b>

# LynTec RPC

## Quick Start Guide

- 1 Make sure that the panel(s) have been wired by a qualified electrician and that there is power to the panel(s).  
Confirm that RPS (slave) panels are connected to the master as indicated in the "RPC to RPS Wiring Instructions" bulletin.
- 2 Confirm that the electrician has connected the 15A breaker in the master panel (position 21) to the power supply in the lower sidecar.

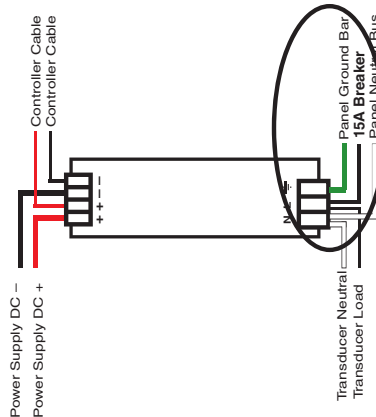

- 3 Once the 15A breaker is connected and switched on, confirm that the orange power LEDs on each circuit board are lit.

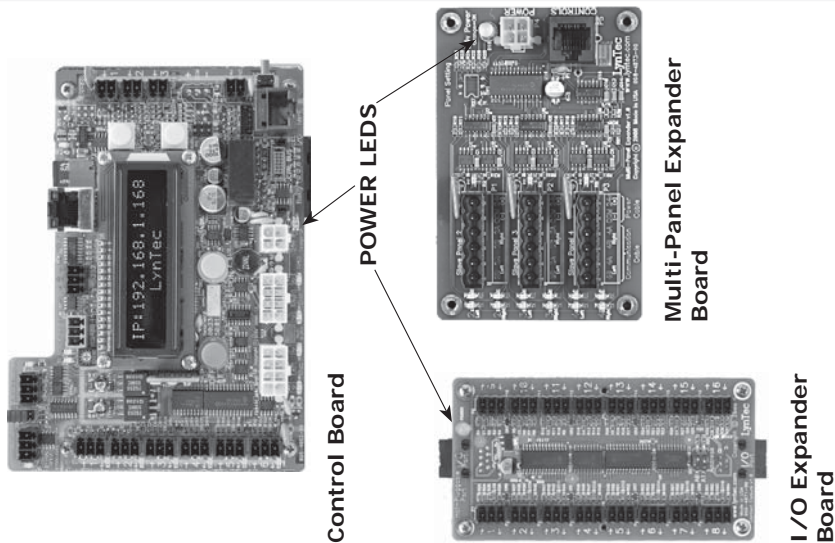

If LEDs do not light, check chapter 4 of the RPC manual to see that circuit boards are connected properly.

139-0522-00 RPC Quicksheet

## RPC Quickstart Guide

- 4 Connect a computer to the control board using a CAT5 crossover cable OR connect the RPC to your network.

**If connecting via a crossover cable:**

With a computer directly connected to the RPC through the Ethernet port, change the computer's IP address manually so it is in the same default IP subnet that the RPC uses: 192.168.1. The default IP address of the RPC is 192.168.1.250.

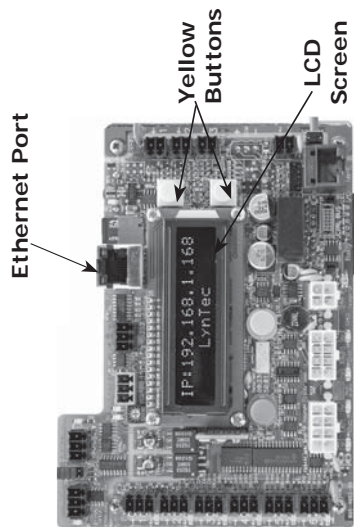

**If connecting via a network:**

Connect the RPC to the network via the Ethernet port. Push the upper yellow button twice or until the IP address appears on the LCD screen.

- 5 Open a web browser and access the status page via the IP address of the RPC.  
(ex. <http://192.168.1.250>)

**The default username is “admin” and the initial password is “pw”.**

If desired, set your username and password on the “Setup Home” page under the “Setup” tab.

The screenshot shows a web interface with a navigation bar at the top containing: Status, Control, Setup, Contact, Network, Panels, Schedules, Contact Closures. The main content area is divided into three sections:

- Contact Information:** A table with the following data:
 

Serial Number	2
Job Name	Infocomm 2009
Contractor Name	Happy Electric
Phone #	800-GET-RPC1
System Integrator	Smiling Comm.
Phone #	800-ADD-CTLR
- Clock Set:** A table with the following data:
 

Year (##)	9
Month (##)	2
Day (##)	26
Hour (##)	3
Min (##)	8
Sec (##)	45
- Password Reset:** A form with the following data:
 

Username	admin
Password	
Repeat Password	

- 6 Complete the RPC setup by following the steps in Chapter 5.

# RPCR Quickstart Guide

3 Connect a computer to the control board using a CAT5 crossover cable OR connect the RPC to your network.

**If connecting via a crossover cable:**

With a computer directly connected to the RPC through the Ethernet port, change the computer's IP address manually so it is in the same default IP subnet that the RPC uses: 192.168.1. The default IP address of the RPC is 192.168.1.250.

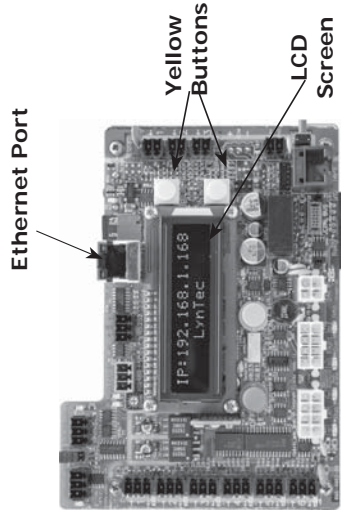

**If connecting via a network:**

Connect the RPC to the network via the Ethernet port. Push the upper yellow button twice or until the IP address appears on the LCD screen.

# OVER

1 Once transformer primary wiring is connected and source power is energized, confirm that the orange power LEDs on each circuit board

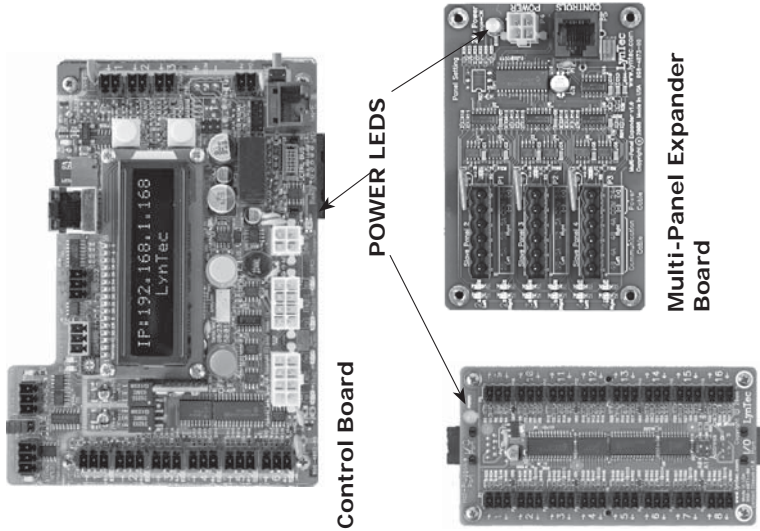

2 If LEDs do not light, check chapter 4 of the RPC manual to see that circuit boards are connected properly.

139-0598-01 RPC-R Quicksheet

# LynTec RPC-R Quick Start Guide

- 4 Open a web browser and access the status page via the IP address of the RPC. (ex. <http://192.168.1.250>)

**The default username is “admin” and the initial password is “pw”.**

If desired, set your username and password on the “Setup Home” page under the “Setup” tab.

The screenshot shows a web interface with a top navigation bar containing: Status, Control, Setup, Support, Event Log, Logout. Below this is a sub-navigation bar with: Setup Home, Network, Panels, Alerts, Contact Closures. The main content area is divided into several sections:

- Contact Information:** A table with fields for Serial Number, Job Name (Lyntec Test Job), Contractor Name (Price Electrics), Phone # (800-GET-RPC1), System Integrator (AVI), and Phone # (800-ADD-CTLR).
- Clock Set:** A form with fields for Year (00-99) (14), Month (1-12) (10), Day (1-31) (21), Hour (0-23) (14), Min (0-59) (40), and Sec (0-59) (38). A note states: "Note: Only changed clock values will be updated." There is an "Update Information" button.
- Schedules:** A section with a checkbox for "Use Schedules" and a dropdown menu set to "Tuesday".
- Printable Pages:** Radio buttons for Network Setup, Panel Setup, and Panel Schedules (selected). Includes a "Print Pages" button.
- Password Reset:** A note: "Note: If the root username or password updated successful, you will be prompted for login information before the webpage will reload." Fields for User Level (Super), Username, Password, and Repeat Password. Includes an "Update Login Info" button.
- Update Web Page Software:** A "File" section with a "Choose File" button and "No file chosen" text. Includes an "Upload Web Pages" button.
- Update Firmware:** A "File" section with a "Choose File" button and "No file chosen" text. Includes an "Upload Firmware" button.
- Reboot RPC:** A "Reboot RPC" button. A note: "Note: New Firmware does not take affect until the RPC has been rebooted."

- 0 Complete the RPC setup by following the steps in Chapter 5.



# LynTec RPC

## Contact Closure Wiring Instructions

Using a standard LynTec SS-2 Switch Set with illuminated ON switch. (For other types of switches, consult CH 4 of the instruction bulletin for wiring diagrams.)

- 1 Confirm that RPS (slave) panels are properly connected to the master as indicated in the "RPC to RPS Wiring Instructions" bulletin.
- 2 Complete all the steps in the "RPC Quick Start Guide".

- 3 Wire the ON switch to a digital I/O port on the left edge of the Controller board as follows:
  - A. Connect the 24VDC Common (center terminal of the I/O port) to the C pin of the ON switch.
  - B. Connect the Input terminal (arrow pointing towards header) to the NO pin of the ON switch.
  - C. Connect the Output terminal (arrow pointing away from header) to the - pin of the ON switch.
  - D. Connect a jumper between the C pin and the + pin of the ON switch.

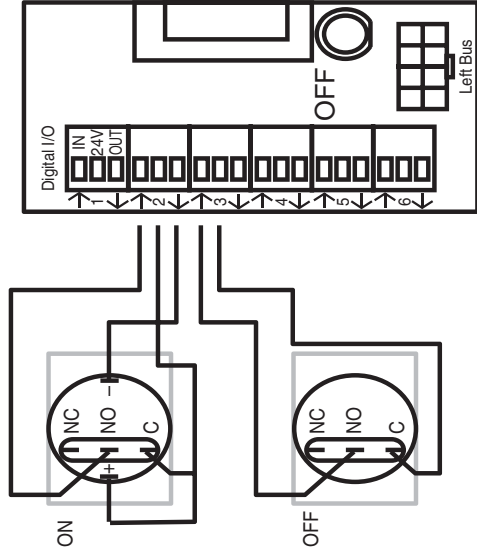

**Note: If using emergency override features, fire alarm contact closures must be wired into port 1.**

- 4 Wire the OFF switch to a digital I/O port on the left edge of the Controller board as follows:
  - A. Connect the 24VDC Common terminal to the C pin of the OFF switch.
  - B. Connect the Input terminal to the NO pin of the OFF switch.
- 5 On the RPC web page, go to the contact closure page. (SETUP==>CONTACT CLOSURES)

- 6 Configure the digital I/O port.  
**Note: If the Emergency Shutoff feature is selected, the first position in the Onboard field (on the Controller) is automatically assigned to that.**
- A. Rename each contact closure as desired
  - B. Click the M (merge) button at the right side of the first of the two ports used. The name box and M button in the second port should turn gray and the Action selections should default to Momentary NO. (normally open)
  - C. Ensure that both of the Action selections for both ports are set to Momentary NO.
  - D. Click the "Save Changes" button at the top of the Onboard I/O box.

- 7 Assign the contact closure to a zone in the "Panel" (SETUP==>PANELS) screen:
- A. In the ZONE CONTROL box under "CC/Schedule", choose which contact closure to assign to any zone using the drop down box.
  - B. Enable the zone by selecting Sequenced or Grouped operation under "Name/Seq".
  - C. Save changes.

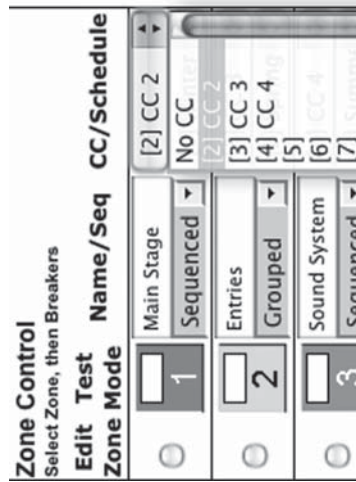

- 8 Verify proper operation of your Switch Set:
- A. Press the ON switch. Breakers in the selected zone should immediately begin actuating.
  - B. The ON indicator should flash steadily until all of the breakers are in the on state.
  - C. When the zone has completed, the ON indicator should remain constantly lit.
  - D. Press the OFF switch. Breakers in the selected zone should immediately begin actuating.
  - E. The ON indicator should flash steadily until all of the breakers are in the off state.
  - F. When the zone has completed, the ON indicator should remain constantly dark. Note: When using two illuminate pushbuttons the OFF indicator will remain constantly lit when the zone has completed. (OFF indicator will extinguish immediately when ON is pressed again.)

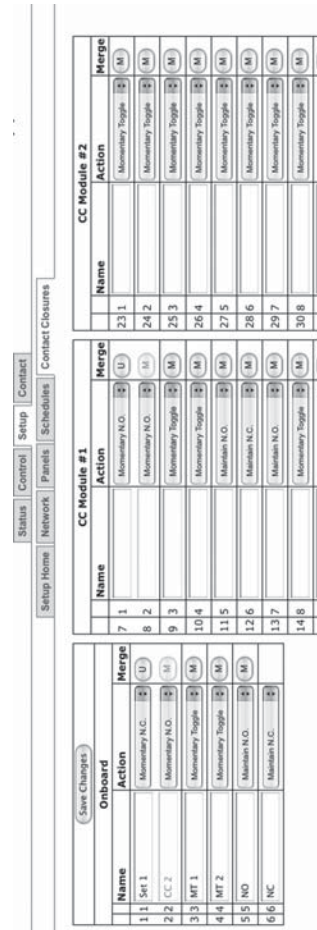

## Appendix B--RS-232 and TCP/IP Protocols

### RS-232 PROTOCOL

Table B-1 Command Codes

Command	Decimal	Hexidecimal
Start Byte	176	0xB0
Activate breakers	180	0xB4
Deactivate breakers	181	0xB5
Request all breakers status	183	0xB6
Activate zones	183	0xB7
Deactivate zones	184	0xB8
Request zones status	185	0xB9
Event ON	186	0xBA
Event OFF	187	0xBB
Event status	188	0xBC
Request breakers status	189	0xBD
Request bus status	190	0xBE
Breaker status identifier	200	0xC8
Zone status identifier	201	0xC9
Event status identifier	202	0xCA
Emergency override identifier	203	0xCB
Checksum identifier	204	0xCC
Checksum digits	205-214	0xCD - 0xD6
Stop byte	240	0xF0

#### Addressing Scheme

##### Breaker address:

1 byte. Numbers 1 through 168 (0x01 – 0xA8) are assigned to populated breakers in sequential order

Zone number: 1 byte (1-12)

#### Breaker Related Commands

##### Activate breakers

*0xB0, 0xB4, breaker\_address\_1, ..., breaker\_address\_m, 0xF0*

*breaker\_address\_1, ..., breaker\_address\_m* – addresses of breakers to be activated  $m \leq 168$

**Deactivate breakers**

*0xB0, 0xB5, breaker\_address\_1, ..., breaker\_address\_n, 0xF0*

breaker\_address\_1, ..., breaker\_address\_n – addresses of breakers to be deactivated n<=168

**Activate/deactivate breakers**

*0xB0, 0xB5, breaker\_address\_1, ..., breaker\_address\_m, 0xB6, breaker\_address\_1, ..., breaker\_address\_n, 0xF0*

breaker\_address\_1, ..., breaker\_address\_m – addresses of breakers to be activated  
breaker\_address\_1, ..., breaker\_address\_n – addresses of breakers to be deactivated  
m+n<=168

**Request all breakers status**

*0xB0, 0xB6, 0xF0*

**Request breakers status**

*0xB0, 0xBD, breaker\_address\_i, breaker\_address\_j, ..., breaker\_address\_n, 0xF0*

breaker\_address\_1, ..., breaker\_address\_n – addresses of breakers, status of which is requested

**Request bus status**

*0xB0, 0xBE, bus, 0xF0*

bus=0-7 – number of bus, status of which is requested

**Reply to activate/deactivate breakers command: status of updated breakers**

*0xB0, 0xC8, breaker\_address\_i, breaker\_status\_i, breaker\_address\_j, breaker\_status\_j, ..., breaker\_address\_n, breaker\_status\_n, 0xF0*

breaker\_address\_i, breaker\_status\_i, breaker\_address\_j, breaker\_status\_j, ..., breaker\_address\_n, breaker\_status\_n

Addresses and status of breakers updated by the command reply is generated for

**Reply to request breakers status command:**

Same format as "Request Bus Status"; contains addresses and status of the breakers specified in the request command

**Reply to request all breakers status command: status of all breakers**

*0xB0, 0xB6, byte\_1, ..., byte\_84, 0xF0*

byte\_i: bits 7-4: status of breaker # 2i, bits 3-0: status of breaker # 2i-1, i=1-84

**Reply to request bus status command: status of all breakers of the requested bus**

*0xB0, 0xBE, byte\_1, ..., byte\_11, 0xF0*

byte\_i format is identical to 3.9, except i=1-11

**Breaker status description (4 bits) (3,5 &6 panels only)**

Value	1	2	3	4	5	6
Status	Off	On	Tripped	Faulty	Empty	Manual On

**Zone Related Commands**

**Activate zone**

*0xB0, 0xB7, zone\_number\_1, ..., zone\_number\_m, 0xF0*

zone\_number\_1, ... zone\_number\_m – numbers of zones to be activated m<=12

**Deactivate zone**

*0xB0, 0xB8, zone\_number\_1, ..., zone\_number\_n, 0xF0*

zone\_number\_1, ... zone\_number\_n – numbers of zones to be deactivated n<=12

**Activate/deactivate zone**

*0xB0, 0xB7, zone\_number\_1, ... zone\_number\_m, 0xB8, zone\_number\_1, ..., zone\_number\_n, 0xF0*

zone\_number\_1, ... zone\_number\_m – numbers of zones to be activated  
zone\_number\_1, ... zone\_number\_n – numbers of zones to be deactivated  
m+n<=12

**Request zones status**

0xB0, 0xB9, 0xF0

**Reply to activate/deactivate zone command: status of updated zones**

0xB0, 0xC9, zone\_address\_i, zone\_status\_i, zone\_address\_j, zone\_status\_j, ..., zone\_address\_n, zone\_status\_n, 0xF0

zone\_address\_i, zone\_status\_i, zone\_address\_j, zone\_status\_j, ..., zone\_address\_n, zone\_status\_n – addresses and status of zones updated by the command reply is generated for

**Reply to request zone status command: status of all 12 zones**

0x40, 0xB9, byte\_1, byte\_2, byte\_3, 0x80

byte\_i: bits 7-6: status of zone # 4i, bits 5-4: status of zone 4i-1, bits 3-2: status of zone 4i-2, bits 1-0: status of zone 4i-3, i=1-3

**Zone status description (2 bits)**

<b>Value</b>	1	2	3
<b>Status</b>	Off	On	Sequencing

**Event Related Commands**

**Event ON**

0xB0, 0xBA, event\_number\_1, ..., event\_number\_m, 0xF0

event\_number\_1, ... event\_number\_m – numbers of events to be turned on

m<=2

**Event OFF**

0xB0, 0xBB, event\_number\_1, ..., event\_number\_n, 0xF0

event\_number\_1, ... event\_number\_n – numbers of events to be turned off

n<=2

**Event ON/OFF**

0xB0, 0xBA, event\_number\_1, ... event\_number\_m, 0xBB, event\_number\_1, ..., event\_number\_n, 0xF0

event\_number\_1, ... event\_number\_m – numbers of events to be activated

event\_number\_1, ... event\_number\_n – numbers of events to be deactivated

$m+n \leq 2$

**Request event status**

*0xB0, 0xBC, 0xF0*

**Reply to activate/deactivate event command: status of updated events**

*0xB0, 0xCA, event\_address\_i, event\_status\_i, < event\_address\_j, event\_status\_j>, 0xF0*

event\_address\_i, event\_status\_i, < event\_address\_j, event\_status\_j>- addresses and status of events updated by the command reply is generated for

**Reply to request event status command: status of all 2 events**

*0xB0, 0xBC, status\_byte, 0xF0*

status\_byte: bits 3-2: status of event #2, bits 1-0: status of event #1

**Event status description (1 bit)**

<b>Value</b>	1	2	3
<b>Status</b>	Off	On	Processing

**Device Discovery**

**Beacon request**

*"AMX\r"*

**Beacon**

*"AMXB<-SDKClass=Utility><-Make=Lyntec><-Model=RPC><-Revision=1.1.4>\r"*

(rev changed from 1.1.3; 1.1.3 supported old protocol)

**Emergency override response to breaker, zone, or event on/off command**

If system is in Emergency Override mode, it replies to breaker, zone or event on/off command with emergency override response

## Checksum

*0xB0, 0xCB, 0xF0*

Checksum is optional. It is calculated as a sum of all bytes of the message starting with start byte and ending with checksum identifier. Checksum is transmitted as a sequence of 3 bytes, where 1st byte is (hundreds+0xCD), 2nd byte is (tens+0xCD) and 3rd byte is (units+0xCD). For example, checksum=137 will be transmitted as:

*0xCE, 0xD0, 0xD4*

## TCP/IP PROTOCOL

TCP/IP communications and control via a third party control system is facilitated by the use of the HTTP GET command. In the example below, GET= the RPC's IP address

Example of GET command:

*GET /p2.rpc?IPB002=1*

Three modes of control are:

Breaker control = "B" Zone control = "Z" Event Control = "E"

## Breaker Control = B

Refer to LynTec RPC browser set-up for breaker numbering

*GET /p2.rpc?IPB002=1*

This control string will turn breaker #2 on.

*GET /p2.rpc?IPB002=0*

This control string will turn breaker #2 off.

Control of up to 167 breakers (4 panel system) is possible.

## Zone Control = Z

Configure your zones (breaker groups) using the LynTec RPC browser set-up when connected to the LynTec RPC panel.

*GET /p2.rpc?IPZ002=1*

This control string will turn zone #2 on.

*GET /p2.rpc?IPZ002=0*

This control string will turn zone #2 off.

*GET /p2.rpc?IPE001=1*

This control string will turn event #1 on.

*GET /p2.rpc?IPE001=0*

This control string will turn event #1 off.



**Events Control = E**

Events include:

- Event 1 = "All Breakers ON"
- Event 2 = "All Breakers OFF"
- Event 3 = "Hurry OFF" zips all breakers off fast.
- Event 4 = "EO" Emergency override (status only)
- Event 5 = "Audio Timer" (NA) (status only)
- Event 6 = "BO" Brown-Out (status only)
- Event 7 = "DMX/sACN"
- Event 8 = "EL" Emergency Lighting

Verification Scheme:

The following GET command will return the current status of all breakers, zones and events in the RPC system.

```
GET /p2.rpc
```

The system will return the following:

```
breakers=10110111111111111111
zones=111111111011
events=1000000
```

The above return is displaying the status of a 20 circuit breakers system in which all are presently ON, with the exceptions of breaker #2 and breaker #5, which are OFF.

The above return is also showing the status of 12 zones, all are ON with the exception of zone #10, which is OFF.

The events return is showing that event #1 is active = "All Breakers ON"

<b>Status returns for Breakers:</b>	<b>Status returns for Zones and Events:</b>
0 = OFF	0 = OFF
1 = ON	1 = ON
2 = Breaker Tripped (panels only)	2 = Processing
3 = Failure	
4 = Manual On (panels only)	
5 = Empty	

## Appendix C--Troubleshooting

### TROUBLESHOOTING THE CONTROLLER

Use the following table if you need to troubleshoot the RPC controller.



## DANGER

### HAZARD OF ELECTRIC SHOCK, EXPLOSION, OR ARC FLASH

- This equipment must be installed and serviced only by qualified electrical personnel.
- Apply appropriate personal protective equipment (PPE) and follow safe electrical work practices. See NFPA 70E.
- Carefully inspect the work area for tools and objects that may have been left inside the equipment.
- Use caution while removing or installing panels so that they do not extend into the energized bus; avoid handling the panels, which could cause personal injury.

**Failure to follow this instruction will result in death or serious injury.**

**Table C-1: RPC Controller Troubleshooting**

Condition	Possible Causes	Solutions
Controller LEDs and status indicators do not illuminate.	Power supply is not energized.	Verify that the power supply's LED status indicators are ON. Make sure the 15A breaker that provides power to the power supply is on. Also, verify that the power supply line terminal is secured. Refer to the Power Supply instruction bulletin for installation and safety information.
	Controller is not receiving power from the power supply.	Make sure the 15A breaker that provides power to the power supply is on.
	The power supply is not operating.	Verify that the power supply is wired correctly. See <b>Chapter 4</b> .
Motorized circuit breaker does not respond to input change or does not respond as desired.	Controller or power supply is not powered or operating properly.	Verify that both the controller and power supply are energized by observing that all power LEDs are illuminated. Verify that the controller is operating by observing that the CPU LED is blinking.
	Circuit breaker handle is OFF.	Turn circuit breaker handle to ON.
	Circuit breaker is tripped.	Reset the circuit breaker by turning it OFF and then back ON.
	Circuit breaker Manual mode is engaged.	Restore the circuit breaker to Auto mode by engaging the white button located on the face of the circuit breaker.
	Input is not connected or wired properly.	Verify that the input wiring is properly connected. Wiring specifics depend on the type of external switching device being used. Refer to <b>Chapter 4--Wiring</b> for more information.
	Circuit breaker is not included in zone, or an incorrect circuit breaker is included in zone.	To test all circuit breakers assigned to a zone, first verify that all circuit breakers are in Auto mode. Enter the Setup page and verify that the breaker is assigned to the correct zone. If the circuit breakers are not responding as desired, refer to <b>Chapter 5--Control Setup</b> for more information on how to add or delete a circuit breaker in a zone.
	Sub-net wiring error.	Circuit breakers in slave panels must have properly wired sub-net communications and power. Refer to <b>Chapter 5--Control Setup</b> , as well as instruction bulletins for the control bus, power supply, and slave address selector, for more information.
Sub-net addressing error.	Each slave panel must have a unique address. Verify that no two slave address selectors have the same address setting and that no slave address selector is set to zero, unless the power supply and controller are remotely mounted with no control bus attached. Refer to the Slave Address Selector instruction bulletin for more information.	

# Appendix D--RPC System Components

The LynTec system consists of control buses, a panelboard, remotely operated circuit breakers, a power supply, a buffer, a transducer and a controller. Optional expansion boards are available to add up to three additional panels or 16 or 32 additional I/o outputs. Figure B-1 identifies main components which are described in this appendix.

Figure D-1

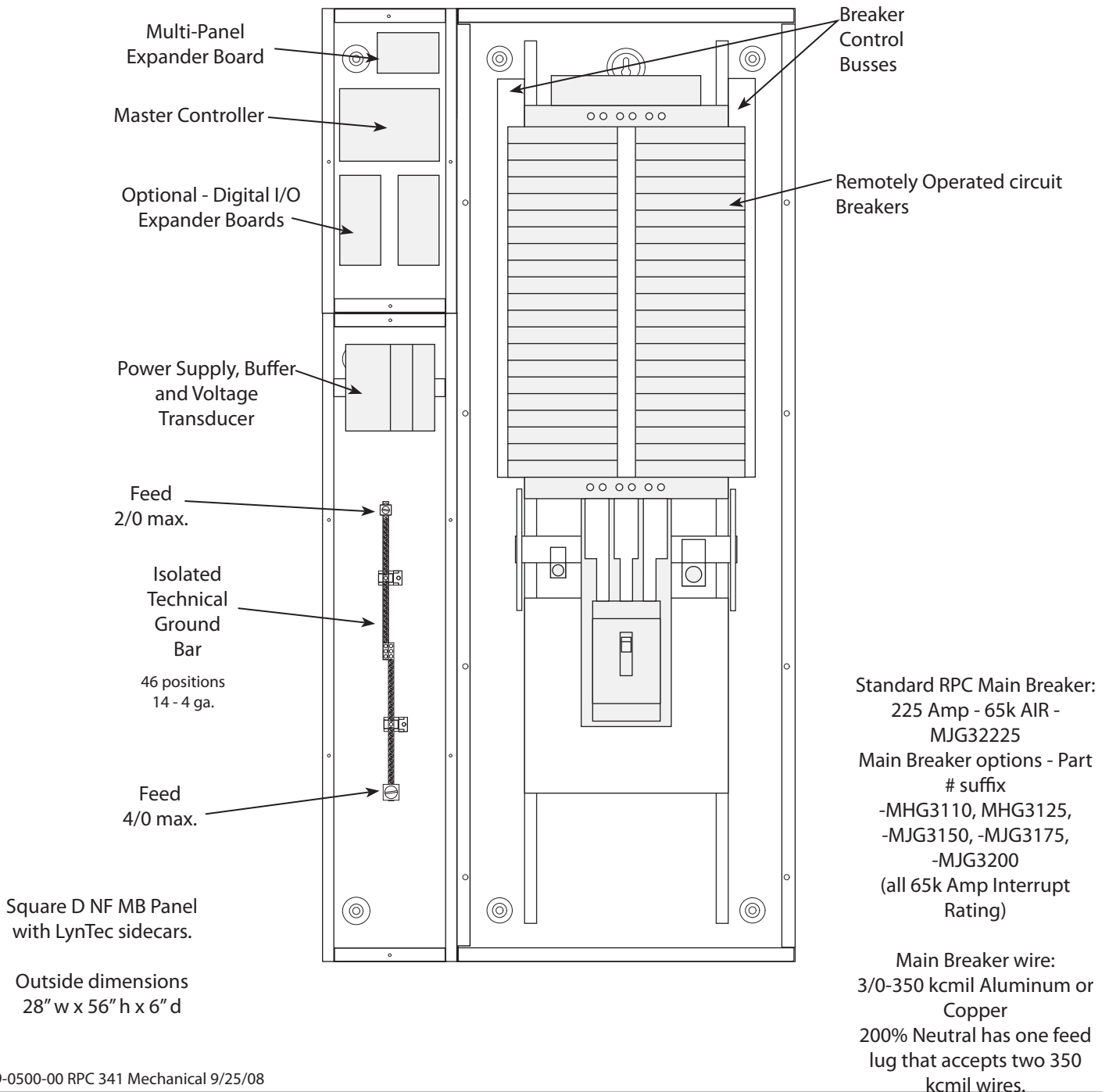

## Control Bus

The control buses provide control and data monitoring for remotely operated circuit breakers and are connected to the power supply and controller. Installed control buses will not interfere with the installation of standard circuit breakers into the panelboard.

Figure D-2

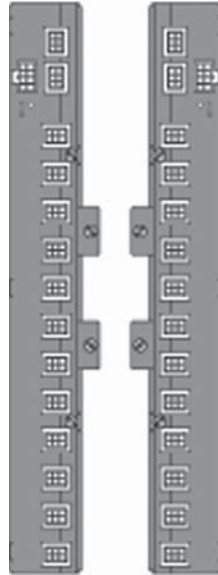

## Remotely Operated Circuit Breakers

Remotely Operated Circuit Breakers provide the same overcurrent protection as standard circuit breakers, and have an integral operator that can remotely switch the circuit breaker ON and OFF. The circuit breaker works with the RPC controller, power supply, and control buses to provide a remote power switching system in a panelboard.

Figure D-3

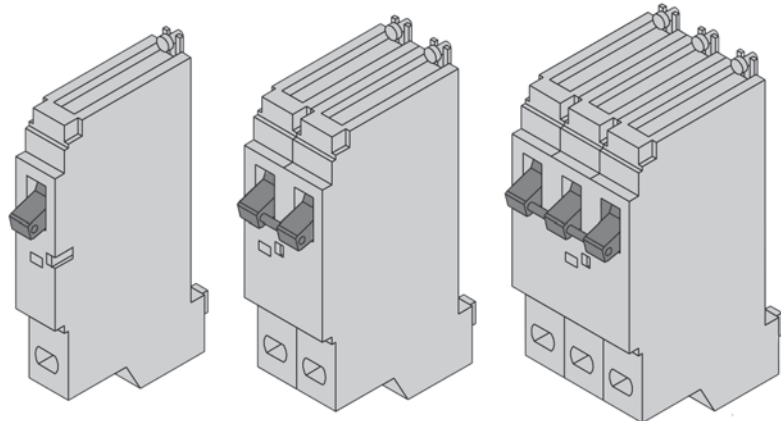

Part Numbers:  
 MBR-15  
 MBR-20  
 MBR-30

Part Numbers:  
 MBR-215  
 MBR-220  
 MBR-230

Part Numbers:  
 MBR-315  
 MBR-320  
 MBR-330

**Power Supply**

The Power Supply connects to a 15A non-motorized breaker and provides 24VDC, 3A power to the RPC controller.

**Figure D-4**



**Buffer**

The buffer stores DC power and discharges it during a brownout or power loss condition to turn off selected breakers (up to four panels). This is a capacitive buffer and is lead and acid free.

**Figure D-5**



**Transducer**

The transducer converts incoming AC line voltage to a varying DC output, allowing the RPC to monitor line voltage.

**Figure D-6**



## Controller

The RPC Controller provides control logic for the operation of a RPC system. The controller uses remotely operated circuit breakers to control up to 167 remotely operated branch circuits. The built in web server allows for easy setup and operation. Also, it provides input channels for connecting external dry-contact control devices.

Figure D-7

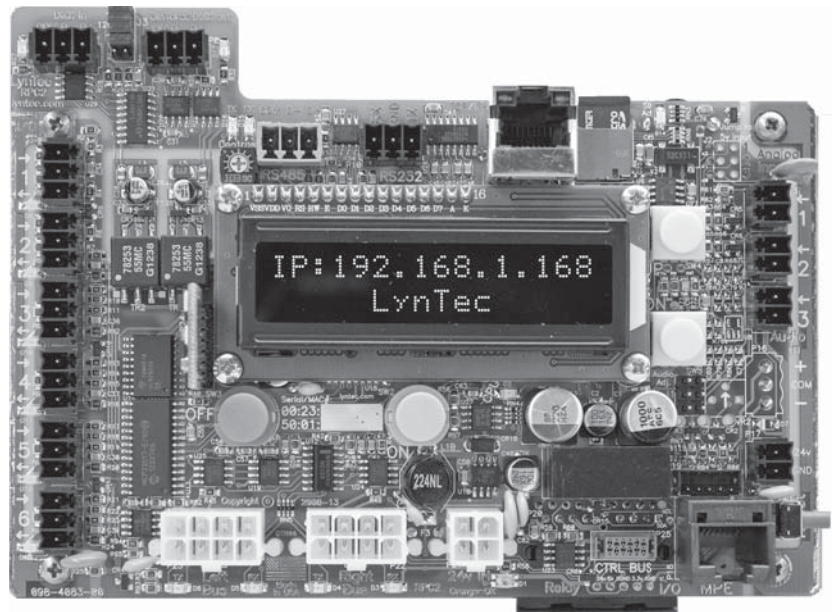

## Slave Address Selector

The slave address selector is used to set an address for a control bus on a slave panelboard.

Figure D-8

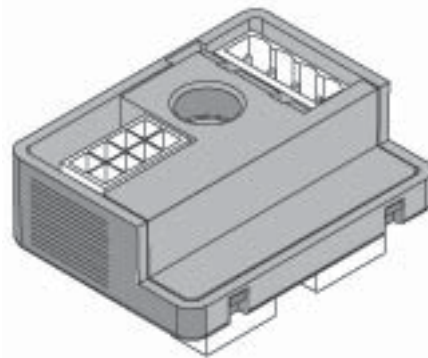

Inputs	Six (6) independently configurable digital inputs/outputs
Input Types	Maintained N.O. Maintained N.C. Momentary N.O. Momentary N.C. Momentary toggle Three (3) analog inputs 0-5 or 0-10VDC Thirty-two (32) I/O ports on optional expander boards
Status Output	24 Vdc (60mA maximum load for all outputs combined) Indicator output on each I/O port
Auxiliary Power Supply	24 Vdc (200mA maximum Current)
Communication Interface	RJ-45 (8P8C) Ethernet/Web Server DMX in/thru 3-wire RS-232 3-wire
Circuit breaker delay	0.025 sec to 8 min (selectable)
Environmental Standards	Operating Temperature: -5°C to +65°C (internal panelboard temperature) Storage Temperature: -20°C to 85°C Operating Humidity: 5% to 95%
Time Clock	Operation during absence of power = >2 years
Memory Retention	Program: > 20 years
Standards	UL 508A CSA C22.2-14
ESD Immunity	IEC 1000, Level 4
RF Susceptibility	IEC 1000, Level 3
Electrical Fast Transient Susceptibility	IEC 1000, Level 3
Electrical Surge Suceptibility--power line	IEC 1000, Level 4
Electrical Surge Suceptibility--data line	IEC 1000, Level 3
FCC--Part 15, Class A	
ETL Tested to: CU 22.2-14 and UL508A	