

Wireline™ Advantage®

Automatic Electric Projection Screen Model



SPECIFICATION DATA

SUGGESTED SPECIFICATIONS: _____ projection screen(s), _____(H) x _____(W), electrically operated 120 volt (60Hz), not more than 3.0 amp motor. Shall have specially designed motor mounted inside the roller, to be two wire with ground, quick reversal type, oiled for life, with automatic thermal overload cutout, integral gears, capacitor and an electric brake to prevent coasting. To have preset but adjustable limits to automatically stop picture surface in the "up" and "down" positions. Junction box shall be internally integrated into the housing making it possible to install the housing and wire to the building's electrical system during construction. Rigid metal roller, to be at least 7" in diameter. Roller designed to be two piece disconnect system that drops material from top of case on 1/8" 7/19 galvanized aircraft cable (29' maximum). The motorized fabric and roller assembly to be installed in the case at the factory. Roller mounting brackets to be adjustable to allow centering or offsetting of the screen within the case. Screen to be

designed for left or right-hand motor installation. Screen fabric to be flame retardant and mildew resistant vinyl with black masking borders standard. Each side of the fabric to have tab guide cable system to maintain even lateral tension and hold surface flat. Custom slat bar with added weight maintains vertical tension on the screen surface. Case to be made of extruded aluminum powder coated white. End caps to be of heavy gauge steel, powder coated white. Bottom of case to have a removable access door. Door to be of extruded aluminum powder coated white. Bottom of case to be self-trimming, with a built-in flange around the bottom of the case. Unit to be furnished with RF remote controlled motor. Suitable for use in environmental air space in accordance with section 300-22 (c) of the National Electric Code, and sections 2-128, 12-010 (3) and 12-100 of the Canadian Electrical Code, part 1, CSA C22.1. Screen to be listed by Underwriters' Laboratories.



HDTV (16:9) Format Dimensions

Viewing Area (H x W)		Nominal Diagonal		Overall Length of Case*		Approximate Net Weight		Approximate Shipping Weight	
In.	Cm	In.	Cm	In.	Cm	Lbs.	Kg	Lbs.	Kg
65" x 116"	165 x 295	133"	338	148½"	377	250	113.4	460	208.7
78" x 139"	198 x 353	159"	404	172½"	438	380	172.4	590	267.6
92" x 164"	234 x 417	188"	478	196"	498	405	183.7	615	279.0
108" x 192"	274 x 488	220"	561	226¼"	575	450	204.1	660	299.4

Wide (16:10) Format Dimensions

Viewing Area (H x W)		Nominal Diagonal		Overall Length of Case*		Approximate Net Weight		Approximate Shipping Weight	
In.	Cm	In.	Cm	In.	Cm	Lbs.	Kg	Lbs.	Kg
72½" x 116"	184 x 295	137"	348	148½"	377	250	113.4	460	208.7
87" x 139"	221 x 353	164"	417	172½"	438	380	172.4	590	267.6
100" x 160"	254 x 406	189"	480	196"	498	405	183.7	615	279.0
110" x 176"	279 x 447	208"	521	209"	531	430	195.0	640	290.3
120" x 192"	305 x 488	226"	565	226¼"	575	450	204.1	660	299.4

*Case length does not include trim flange

PRODUCT NOTES

- All surfaces will be seamless.
- All screens standard with 4" black drop at the top and 29' of cable drop.
- Overall case length dimensions +/- ¼".
- Detail dimensional drawings, wiring diagrams and installation instructions available upon request.
- Specifications subject to change without notice.
- Custom formats and sizes available upon request.
- Screen to be furnished with Radio Frequency Wireless Remote and Dry Contact Input Transmitter.

WHEN ORDERING, MARK APPROPRIATE SELECTIONS

- Select size from charts on the other side.
- Select viewing surface (All Da-Lite surfaces are GREENGUARD GOLD Certified.):

<input type="checkbox"/> HD Progressive 0.6	<input type="checkbox"/> HD Progressive 1.3
<input type="checkbox"/> HD Progressive 0.9	<input type="checkbox"/> Dual Vision
<input type="checkbox"/> HD Progressive 1.1	
- Options:

<input type="checkbox"/> Flangeless Case	<input type="checkbox"/> 220/240 Volt (50 Hz) Motor.
--	--
- Optional accessories:

<input type="checkbox"/> Radio Frequency RS-232 Device (120V motor only)	<input type="checkbox"/> Wall Mount Bracket Kit (Only for Flangeless Case Option)
<input type="checkbox"/> Radio Frequency Single Channel Wall Switch	

PRODUCT VIEWS - WITH TRIM FLANGE (STANDARD)

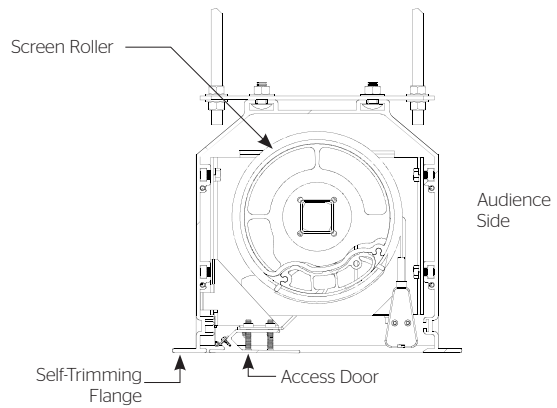
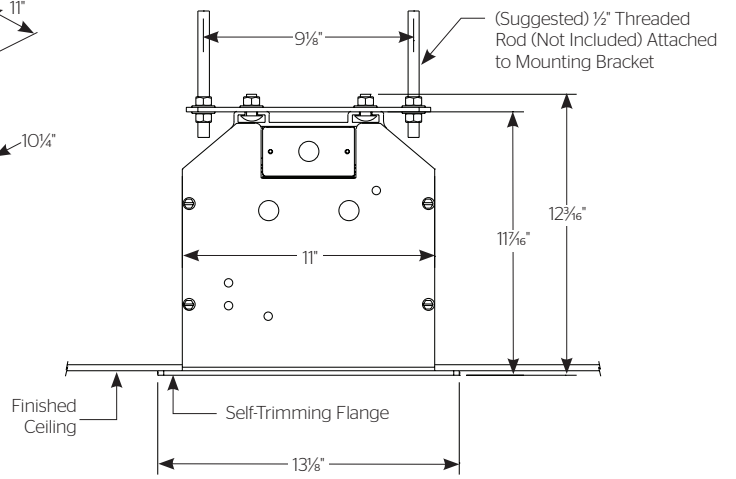
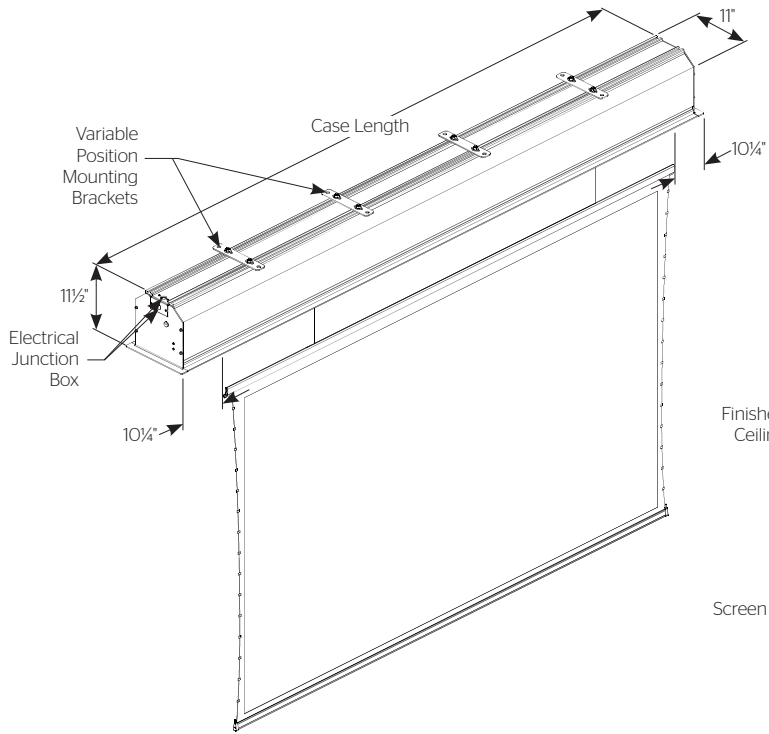

PRODUCT VIEWS - WITHOUT TRIM FLANGE (OPTIONAL)

Ceiling Mount

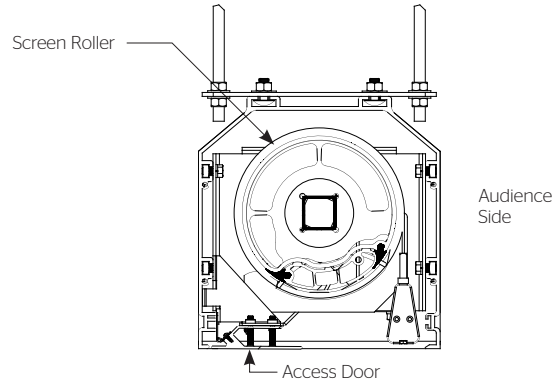
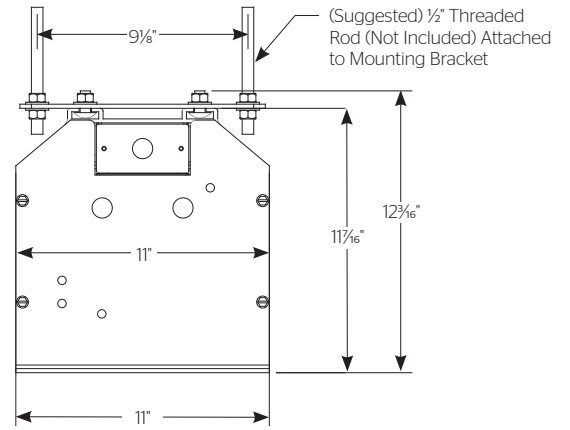
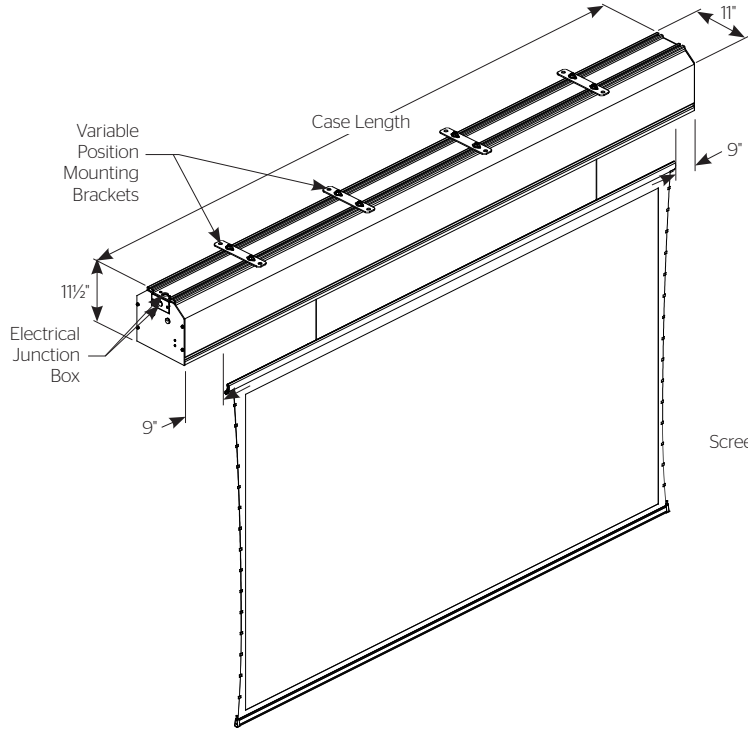

Wall Mount

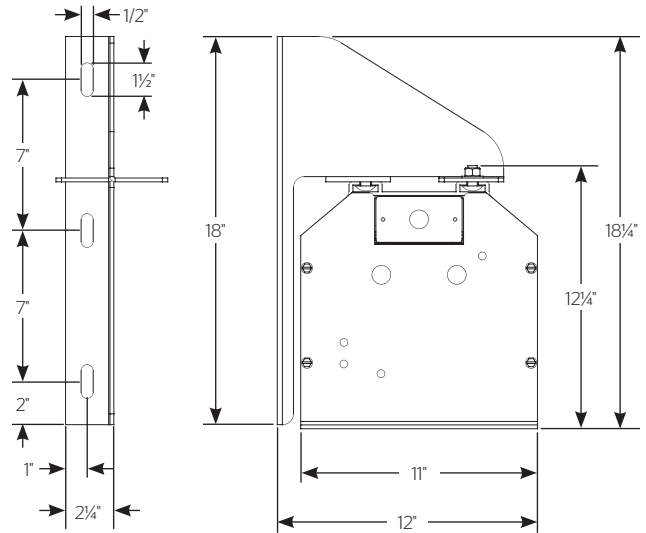
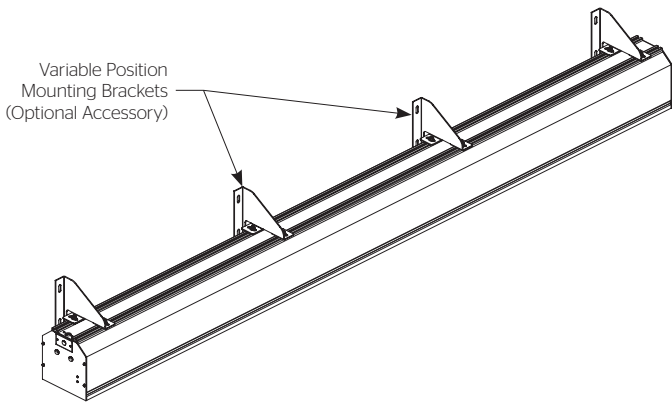

A BRAND OF MILESTONE AV TECHNOLOGIES

www.milestone.com

P 800.622.3737 / 574.267.8101

F 877.325.4832 / 574.267.7804

E info@da-lite.com

In British Columbia, Milestone AV Technologies ULC carries on business as MAVT Milestone AV Technologies ULC.

©2017 Milestone AV Technologies. DL-0619 (Rev. 4) 04:17. Da-Lite is a registered trademarks of Milestone AV Technologies. All other brand names or marks are used for identification purposes and are trademarks of their respective owners. All patents are protected under existing designations. Other patents pending.

Project Name: _____	
Architect: _____	Phone: _____
Contractor: _____	Phone: _____
Supervisor: _____	Phone: _____
Supplier: _____	Date: _____
Revised: _____	