

FS-HDR

Quick Start Guide



Overview

FS-HDR, a 1RU, rack-mount, universal converter/frame synchronizer, is designed specifically to meet the HDR (High Dynamic Range) and WCG (Wide Color Gamut) needs of broadcast, OTT, post and live event AV environments, where real time, low-latency processing and color fidelity is required for 4K/UltraHD and 2K/HD workflows. Developed in partnership with Colorfront, the FS-HDR's HDR/WCG functionality is powered by Colorfront Engine™ proprietary video processing algorithms. FS-HDR also serves as a full, 1-channel up, down, cross-converter for 4K/UltraHD/2K/HD conversion and frame sync needs and in 4-Channel mode, offers 4 independent channels of 2K/HD conversion.

Quick Start Guide Objectives

The FS-HDR can be extremely simple to use, because of its ability to detect incoming signal formats and automatically apply the correct video processing for the selected output format. However, the FS-HDR is also extremely powerful and can be flexibly configured to perform a wide variety of tasks.

This Quick Start Guide is designed to help you get your FS-HDR up and running for the first time, and confirm it is operating properly. It also provides step-by-step instructions that demonstrate a few FS-HDR signal processing examples.

Stand Alone Tests

- ["First Power Up" on page 4](#)
- ["Internal Test Signals" on page 5](#)

Computer Setup

- ["FS-HDR Network Setup" on page 6](#)

Processing Examples

- ["HD Video Camera to UltraHD HDR Live Production" on page 9](#)
- ["4K HDR to HD HDR Down and Cross-Conversion" on page 11](#)
- ["Multiple Legacy Device SDR To HDR Live Conversion" on page 13](#)
- ["Multiple Simultaneous HDR and SDR Distribution" on page 15](#)

For additional information, please see the *FS-HDR Installation and Operation Guide* available on the AJA website.

HDR and WCG Background

High Dynamic Range (HDR) and Wide Color Gamut (WCG) are relatively new ways to present video programming that gives brighter highlights, more detailed shadows, and enhanced colors with smoother gradients. HDR and WCG are display oriented features, dependent on the capabilities of the device presenting the video material.

Standards have been developed to help manage HDR signal flows, including:

- HDR-10 (for HDMI) - Uses a Perceptual Quantizer (PQ) curve that accounts for the human visual response to maximize coding efficiency. This standard also uses static metadata to communicate signal characteristics to the monitor so it can optimize its display characteristics to match the signal.
- Hybrid Log Gamma (HLG) - Uses a combination log and gamma curve to achieve coding efficiency of HDR signals while also allowing the same signal to be shown on both standard and HDR displays. No metadata is required.

Other standards exist, or are in development, including some that have dynamic metadata, which can be used by displays to adjust for the best possible picture from scene to scene.

FS-HDR Colorfront Engine Settings

FS-HDR settings involved in Colorfront Engine transforms for HDR include:

Input Video Dynamic Range & Gamut

- SDR BT.709 100 Nits (default)
- PQ BT.2020 1000 Nits
- PQ P3D65 1000 Nits
- Hybrid Log Gamma BT.2100
- Sony S-Gamut3/S-Log3
- Arri Log C Wide Gamut
- Panasonic V-Log
- Red Log3G10 Wide Gamut
- Canon Log 2
- Canon Log 3

Output Video Format Dynamic Range & Gamut

- SDR BT.709 100 Nits (default)
- PQ BT.2020 1000 Nits
- Hybrid Log Gamma BT.2100
- Sony S-Gamut3/S-Log3

Installation Summary

1. Unpack the shipping box, inspect and inventory the contents, and read the late-breaking news sheet, if any.
2. Install any optional SFP I/O modules by sliding them into the SFP cages in the back. Use only AJA approved modules.

NOTE: The "[Stand Alone Tests](#)" on page 4 can be performed with the FS-HDR sitting on a bench to test system operation before physically installing the unit.

3. Mount the physical chassis: front rack, rear rack, or deskmount—1 RU x 17.5 inches (44.45 cm) x 16 inches (40.65 cm). Do not block air flow through the side vents.
4. Make signal I/O connections to the FS-HDR back panel as shown in [Figure 1](#).

Figure 1. FS-HDR Rear Panel

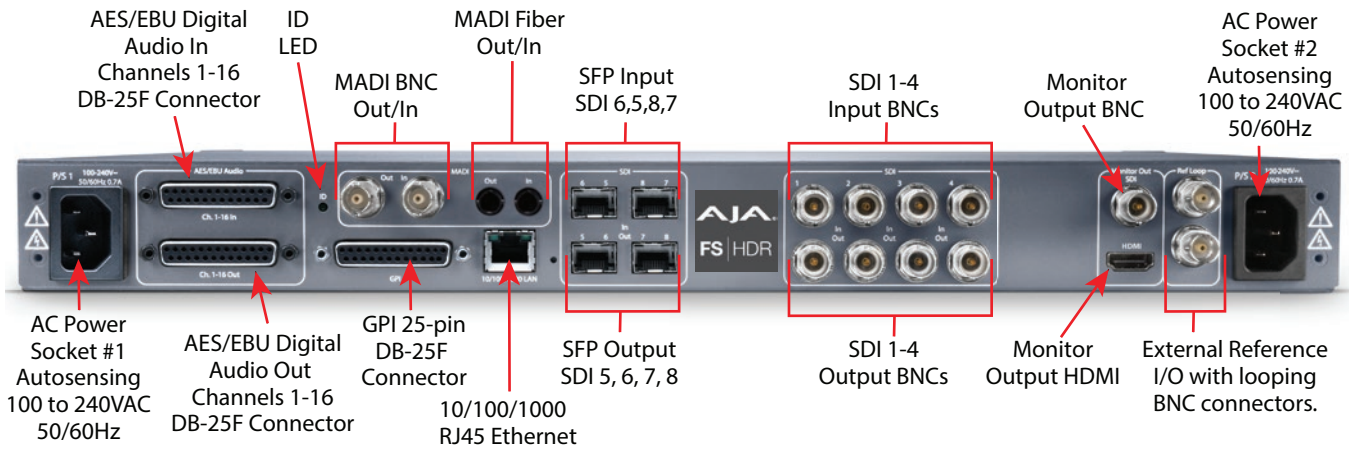

5. Connect one or two power cords to the FS-HDR and mains AC (100-240 VAC, 50/60 Hz, 55 Watts). For redundancy, use both cords and connect them to separate branch circuits. The FS-HDR power supply is autosensing and adjusts to the available power.
6. Connect your computer to the FS-HDR using a CAT5 Ethernet cable to the FS-HDR RJ45 10/100/1000 Ethernet LAN connector. You can connect directly or via a network device such as a switch, hub, bridge, etc. The FS-HDR automatically senses and adjusts to either a straight-through or crossover cable.

NOTE: See ["FS-HDR Network Setup"](#) on page 6 for more detailed instructions.

FS-HDR Control

The FS-HDR front panel buttons and knobs are used with menus in the display, allowing you to fully configure the system. Front panel LEDs report important system statuses. The FS-HDR also has an internal web server that allows remote monitoring and control of parameter setting via an Ethernet 10/100/1000 network-attached computer running a web-browser. Firmware updates are also performed from the web browser.

Figure 2. FS-HDR Front Panel

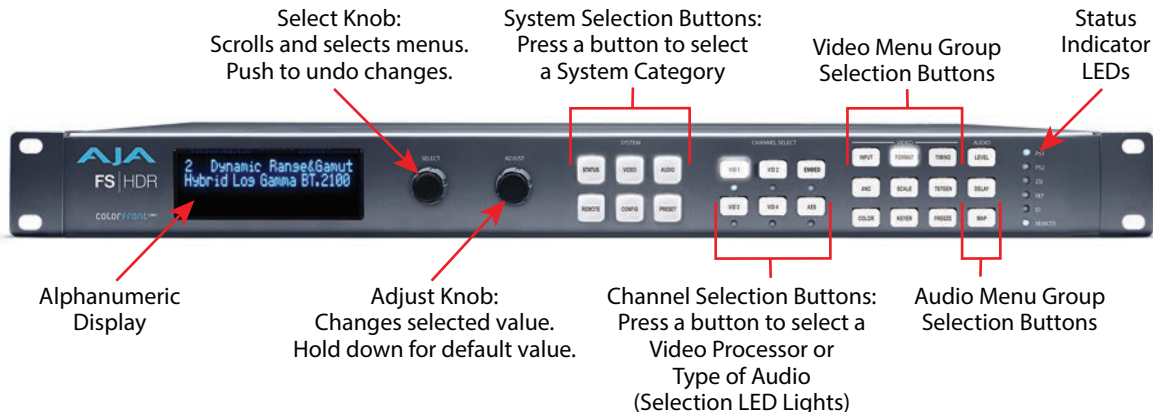

Stand Alone Tests

The stand alone tests can be performed without a computer, using the FS-HDR front panel controls and rear connections. The following procedures assume the FS-HDR is at factory defaults (taken from a newly opened box). If not set to defaults, the FS-HDR may behave differently.

NOTE: FS-HDR units are configured at the factory to operate in Four Channel Mode.

First Power Up

The following workflow powers up a default FS-HDR and demonstrates some example alarms.

Setup

- Ensure the FS-HDR is completely disconnected (all video, audio, network, and power connector ports are empty).

Procedure

1. Connect both FS-HDR power cords to mains AC and allow time for the unit to boot up. Observe the front panel LEDs.
 - The REF LED will light red, indicating an alarm condition. By default the FS-HDR is configured to operate genlocked to an external reference signal.
2. Press the front panel *STATUS* button, then turn the *SELECT* knob to view various Status menus.
 - The Status menu for Video Processor 1 will report No Input for IN1, the port is disconnected), and the *GEN* (Genlock) parameter will report *Ref* (configured for external reference) but will also report *No Input*.

Video Format Status screen			Video Format Alarm Status screen		
IN1	SDI 1	No Input	IN1	SDI 1	OK
BKGD	Black	1080i59	BKGD	Black	OK
GEN	Ref	No Input	GEN	Ref	No Ref
OUT1		1080i59	Rate		59/29/23

3. Connect a 1080i59.94 HD tri-level sync reference signal to one of the FS-HDR Ref Loop BNCs, and connect a 75 ohm terminator to the other Ref BNC.
 - The REF LED will light blue, indicating the FS-HDR is genlocked to an external reference signal.
 - The Status menu *GEN* parameters will report *Ref* and indicate the format of the incoming reference signal or *OK*.
 - However, because the FS-HDR is still not receiving a compatible video input, No Input, will be reported for IN1.

Video Format Status screen			Video Format Alarm Status screen		
IN1	SDI 1	No Input	IN1	SDI 1	OK
BKGD	Black	1080i59	BKGD	Black	OK
GEN	Ref	1080i59	GEN	Ref	OK
OUT1		1080i59	Rate		59/29/23

4. Connect a 1080i59.94 SDI video source to the SDI 1 input BNC.
 - The front panel will report 1080i59 and an OK status for SDI 1. This indicates no alarm condition exists.

Video Format Status screen			Video Format Alarm Status screen		
IN1	SDI 1	1080i59	IN1	SDI 1	OK
BKGD	Black	1080i59	BKGD	Black	OK
GEN	Ref	1080i59	GEN	Ref	OK
OUT1		1080i59	OUT1		1080i59

5. Disconnect one of the power cords, leaving the other attached.
 - The front panel PWR LED will light red for the power supply with the removed cord.
 - The PS status will report PS1 (or 2) OFF
6. Reconnect the power cable. The PWR LED for that power supply will light blue and the power supply status will report OK.

This workflow confirms the FS-HDR powers up successfully and reports reference and power supply alarms.

NOTE: FS-HDR Reference, Power Supply, and Video Format alarms can be disabled, if desired. This will prevent the LEDs from going red, but will not affect front panel status displays.

Internal Test Signals

This workflow generates bars and tone and routes them to an FS-HDR video and audio output. This example uses the SDI 1 and AES output connectors, an SDI video monitor, and an AES audio monitor.

NOTE: In the following procedures, where the terms select and adjust are used, turn the front panel SELECT and ADJUST knobs.

Setup

- Connect the FS-HDR SDI 1 output BNC connector to an SDI video display with a BNC cable.
- Connect the FS-HDR AES/EBU output DB25 connector to an AES audio monitor using a standard TASCAM pinout cable (customer supplied). Separate DB25 connectors carry all 8 AES digital audio pairs (16 audio signals), one connector for input and one for output. Turn the output gain of the audio monitor to a low level.

Procedure

1. Press the VID1 Channel Select button.
2. Press the *FORMAT* Video button
 - Select 1 Output Format and adjust to a signal compatible with your SDI monitor (for example, 1080i59.95).
3. Press the *TSTGEN* Video button.
 - Select 1 Test Pattern Gen and adjust to On.
 - Select 2 Test Pattern and adjust to 75% Bars.
4. Press the AES Channel Select button.
5. Press the *MAP* Audio button.
 - Select 1.0 AES Out and adjust to Sig Gen 400KHz.

You should now be able to see the test signal on the SDI Monitor display, and hear the audio on the AES monitor.

This workflow confirms the FS-HDR generates and outputs video and audio.

FS-HDR Network Setup

The following instructions summarize ways to configure the FS-HDR to communicate with a computer directly or over a network.

Networking Using DHCP or Default Static IP

The FS-HDR factory default configuration automatically looks for a DHCP server to issue an IP address. If your network includes a DHCP server, plug the FS-HDR into the network and connect with the unit as follows:

1. Press the CONFIG button.
2. Turn the SELECT knob to navigate to the Status menu that has the name of the FS-HDR at the top (default is "aja-FS-HDR"). Note the DHCP-supplied IP address shown.
3. With your laptop or desktop computer connected to the same LAN as the FS-HDR and DHCP enabled, type the IP address you noted on the FS-HDR's display into the browser address field and press Enter. You should now see the FS-HDR's browser Status screen.

If the FS-HDR cannot get an address from the network DHCP server, the FS-HDR will automatically use a preset factory static IP address of 192.168.0.2. You can access the FS-HDR using the default static address as follows:

1. Set your computer's IP address to whatever address you prefer in the 192.168.0 (class C) network.
2. Set the computer's Subnet mask to 255.255.255.0 (most PCs default to the proper netmask when the address is set).
3. Set the gateway address, if used, to match the FS-HDR default: 192.168.0.1. Alternatively, change the FS-HDR gateway address to match your gateway:
 - A. Press CONFIG, turn SELECT to 3.4 Default Gateway, push and then turn ADJUST to change the first group of digits.
 - B. Turn SELECT to advance to the next set of numbers, and turn ADJUST to set these numbers.
 - C. Continue using SELECT and ADJUST to set the full address.
 - D. When finished, push ADJUST momentarily to save the address.
5. Run a browser on the computer and type "192.168.0.2" (the factory static IP address). You should now see the FS-HDR's browser status screen.

Networking the FS-HDR Using Your Own Static IP

If you don't want to use DHCP or the default static IP address, you can set your own static IP address:

1. Select the CONFIG button and use the SELECT knob to navigate to parameter 3.1 IP CONFIG. Use the ADJUST knob to select Static.
2. Turn SELECT to navigate to parameter 3.2 IP ADDRESS. The display shows the default static IP address: 192.168.0.2.
3. Change the IP address as follows.
 - A. Push the ADJUST knob momentarily so that the first octet (set of numbers) blinks, and then turn ADJUST to change the numbers.
 - B. Turn SELECT to advance to the next set of numbers, and turn ADJUST to set these numbers.
 - C. Continue using SELECT and ADJUST to set the full address.
 - D. When finished, push ADJUST momentarily to save the address.

5. Turn SELECT to advance to 3.3 Subnet Mask. Use the SELECT and ADJUST knobs as in the previous step to set the desired subnet mask.
6. Turn SELECT to advance to 3.4 Default Gateway. Use the SELECT and ADJUST knobs as in the previous step to set the desired gateway address.
7. Run a browser on the computer and type in the IP address you set for the FS-HDR. You should now see the FS-HDR's Status screen.

Web Browser Menu Summary

Figure 3 summarizes web browser menu operation. The settings generally correspond to the front panel display parameters, providing you two methods of controlling the FS-HDR. To see the equivalent front panel display parameter number, hover the cursor over a setting.

Figure 3. FS-HDR Web Interface, Main Status Screen, Four Ch Mode

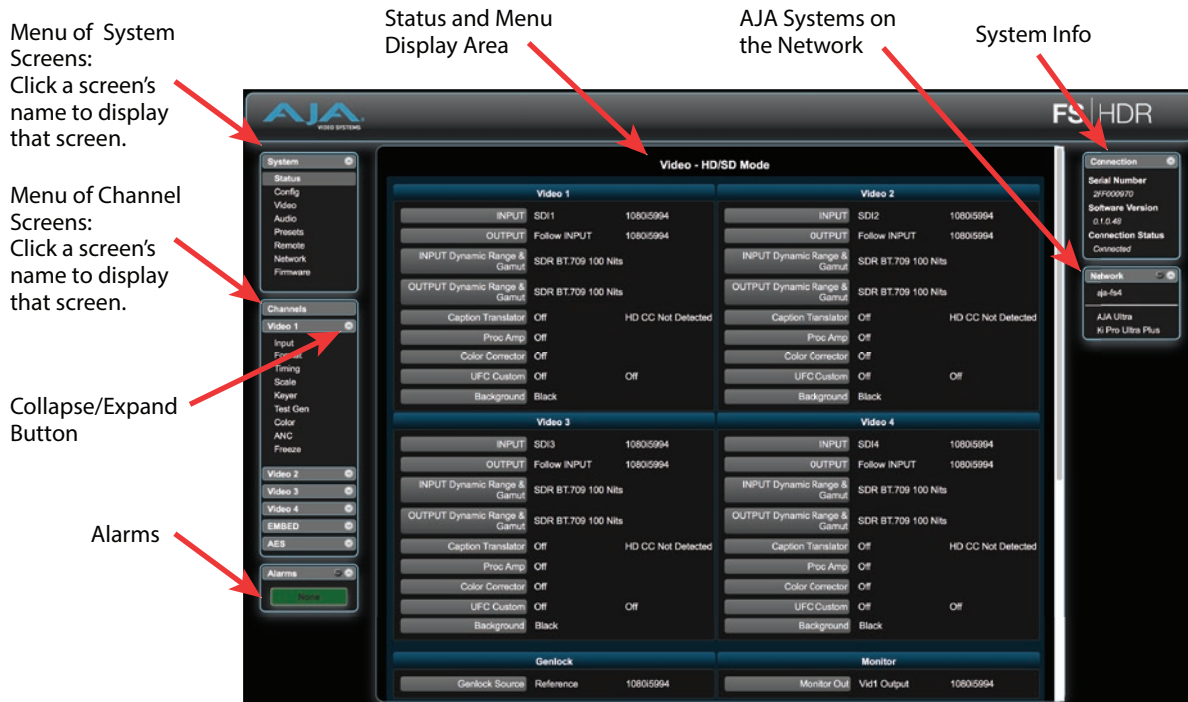

Drop Down Parameter Operation

Most parameters available on the browser are selected from a drop-down list. The currently active parameter is displayed. Click on the down arrow symbol next to the parameter to display the list and select an alternative value. The FS-HDR will immediately operate with the new setting.

Slider Operation

Some screens contain slider controls for setting values. To set a value, you can click on a slider to select it and then use the mouse to drag the slider to the position you desire. For fine tuning, while the slider is selected (highlighted by a blue border), use the keyboard left and right arrow keys to change the value one unit at a time. Or you can enter the value directly by clicking on the number displayed above the slider, type in your number then hit Enter to have it take effect. After setting a slider's position, click on the page's background area (blue highlight turns off) to ensure the change is confirmed and saved.

Sub-Menus

Some parameters, when activated, open sub-menus. The sub-menus are a lighter gray color and have a collapse/expand button on the parent selection. This lets you collapse the sub-menus for easier system configuration. The collapsed setting only stays in effect until the user reconnects or refreshes the browser.

FS-HDR Processing Examples

In the following procedures, your exact actions depend on which FS-HDR interface you are using. Where the terms *MENU NAME*, *select* and *adjust* are used:

- On the front panel interface, press the indicated Menu Group Selection button and then turn the SELECT and ADJUST knobs to choose the parameter and change the setting. The Front Panel menu numbers are included in the procedures.
- On the web browser interface, use your mouse to select the name of the Menu Screen and then choose the parameter and setting using the drop down list or slider. Menu numbers are not present on the FS-HDR web pages.

About FS-HDR Operating Modes

The FS-HDR has two operating modes.

- Single Channel Mode (4K/UHD) has one video processing channel capable of 4K/UltraHD video, and supports up & down-conversion to and from HD video.
- 4 Channel Mode (HD/SD) has four video processing channels capable of HD video, and each channel supports independent up & down-conversion between HD and SD video.

Both operating modes support various types of High Dynamic Range (HDR) and Wide Color Gamut (WCG) video, and can perform conversions between them.

The appropriate FS-HDR operating mode should be selected first, because parameter setting changes only affect the current operating mode.

To change the FS-HDR operating mode:

1. Press the *CONFIG* System button:
2. Select *2 FS-HDR Mode*
3. Select either *4K/UHD* or *HD/SD* and press *ADJUST*.

NOTE: The FS-HDR must restart after its operating mode has been changed.

FS-HDR Processing Examples

General FS-HDR Setup

For any FS-HDR operation the following general menu items will need to be set correctly for your workflow. Some default FS-HDR settings may be applicable. The following items assume front panel control. Web browser control may require additional network configuration steps.

Select Single or Four Channel Mode (Reboot Required)

Config Menu: *2 FS-HDR Mode*

- HD/SD (Four Channel mode), or 4K/UHD (Single Channel mode).

NOTE: See [Step 1 on page 8](#) for procedure.

Select Frame Rate

Video Menu: 1 *Output Frame Rate*

- 59/29/23 (default), or 50/25, or 60/30/24

Select Genlock

Video Menu: 2 *Genlock*

- Reference (default), or Freerun, or SDI (n)

Configure Video Input

VID (n), INPUT Menu, 1 *Input*

- SDI (n) (default), or (n/n) Dual Link, or Quad Link

Configure Video Output

Vid (n), FORMAT Menu, 1 *Output Format*

- Follow Input (default), or Follow Ref, or (raster/framerate)
- Various conversion settings in related menus may also apply.

Dynamic Range Clamp (HDR Output Only)

Vid (n), FORMAT Menu, 2.2 *Dynamic Range Clamp*

The Dynamic Range Clamp parameter can be used to quickly preview what an HDR signal may look like on an SDR monitor, without having to switch between HDR and SDR modes on that monitor (which may go black during the change-over). The FS-HDR default setting is *No Clamp*, and this generally should be used during production. When set to *100 Nits*, the HDR signal is cleanly compressed to SDR, allowing quick A/B comparison on an HDR display in HDR mode.

NOTE: *The Dynamic Range Clamp parameter is only active when PQ BT.2020 1000 Nits or Hybrid Log Gamma BT.2100 HDR video is being output.*

Additional Settings

Other more specialized settings not discussed in the Quick Start Guide may also apply to your workflow. Refer to the *FS-HDR Installation and Operation Guide* available on the AJA website for more information.

HD Video Camera to UltraHD HDR Live Production

The following workflow demonstrates feeding an HD video camera signal to an UltraHD HDR capable video switcher through the FS-HDR for a live production. In this example a Canon camera's HD Log 2 output is converted to UltraHD Hybrid Log Gamma.

Figure 4. Single Channel Mode, HD Up Conversion to UltraHD HDR

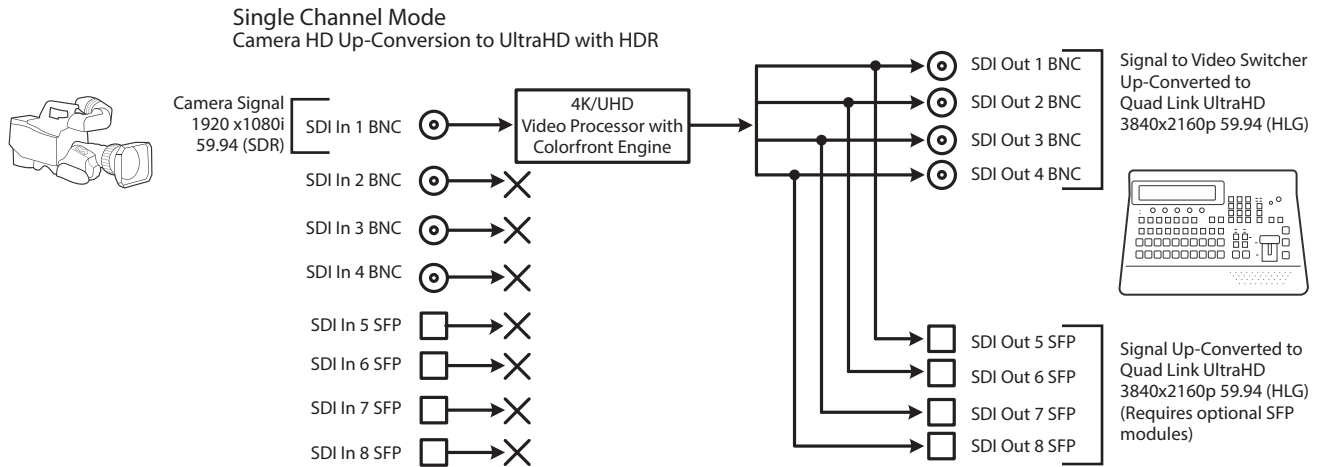

Table 1. Menu Settings for Single Channel Mode, Up Conversion

Channel Select Button	Video Button	Menu Name	Setting
VID1	INPUT	1 Input	SDI1
VID1	INPUT	2.1 Dynamic Range&Gamut	Canon Log 2 (match to camera)
VID1	FORMAT	1 Output Format	UHD2160p5994
VID1	FORMAT	2.1 Dynamic Range&Gamut	Hybrid Log Gamma BT.2100
VID1	FORMAT	2.2 Dynamic Range Clamp	No Clamp (default)
VID1	FORMAT	3.0 Link Cfg SDI1-4	Quad Link LvIA
VID1	FORMAT	4.0 Link Cfg SDI5-8	Quad Link LvIA
VID1	FORMAT	5.0 Output Image Mapping	Quadrant or 2SI (as required)

Setup

- Ensure the FS-HDR is receiving a valid reference signal. Connect a 1080i59.94 HD tri-level sync signal to one of the Ref Loop BNC connectors, and terminate the other Ref Loop BNC connector.
- Configure the camera (for example, SDI 1080i59.94 Canon Log 2)
- Connect the camera's SDI output connector to the SDI1 input on the rear of the FS-HDR. Once connected the FS-HDR front panel VID IN LED will light.
- Connect the four FS-HDR SDI1-4 video output BNC connectors to a UltraHD video production switcher that supports Hybrid Log Gamma.
- View the FS-HDR SDI output signal on a compatible HDR display.

Procedure

System Configuration

1. If the FS-HDR is not already in Single Channel Mode, press the *CONFIG* System button:
 - Select 2 *FS-HDR Mode*, select *4K/UHD* and press the *ADJUST* knob. Wait for the FS-HDR to reboot (not longer than 90 seconds).
2. Press the *VIDEO* System button.
 - Select 1 *Output Frame Rate*, and adjust to *59/29/23*.
 - Select 2 *Genlock Source*, and adjust to *Reference*.

Video Processor Setup

3. Press the *VID1* Channel Select button.
 4. Press the *INPUT* Video button.
 - Select *1 Input*, and adjust to *SDI 1*.
 - Select *2.1 Dynamic Range&Gamut*, and match to the camera, in this example *Canon Log 2*.
 5. Press the *FORMAT* Video button.
 - Select *1 Output Format*, and adjust to *UHD2160p5994*.
 - Select *2.1 Dynamic Range&Gamut* and select *Hybrid Log Gamma BT.2100*.
 - Select *2.2 Dynamic Range Clamp* and ensure *No Clamp* (default) is selected.
- NOTE:** Setting *Dynamic Range Clamp* to *100 Nits* allows you to quickly A/B preview on a connected HDR monitor how the video may appear on an SDR display.
- Select *3.0 Link Cfg SDI1-4* and adjust to *QuadLnk LvlA*.
 - Select *5.0 Output Mapping* and select either *Quadrant* (default) or *2SI* as required for your production.
6. If you have optional SFP output modules installed, you can select *FORMAT 4.0 Link Cfg SDI5-8* and adjust to *QuadLnk LvlA* for an additional copy of that converted signal.

The video switcher should now be able to accept the up-converted UltraHD HLG camera signal.

4K HDR to HD HDR Down and Cross-Conversion

The following workflow demonstrates down-converting a Quad Link 4K input to HD, and simultaneously cross-converting the HDR/WCG format, from PQ (HDR-10) to HLG. The 4096x2160 input will be cropped to 3840x2160 and then down converted.

Figure 5. Single Channel Mode, Down and HDR Cross-Conversion

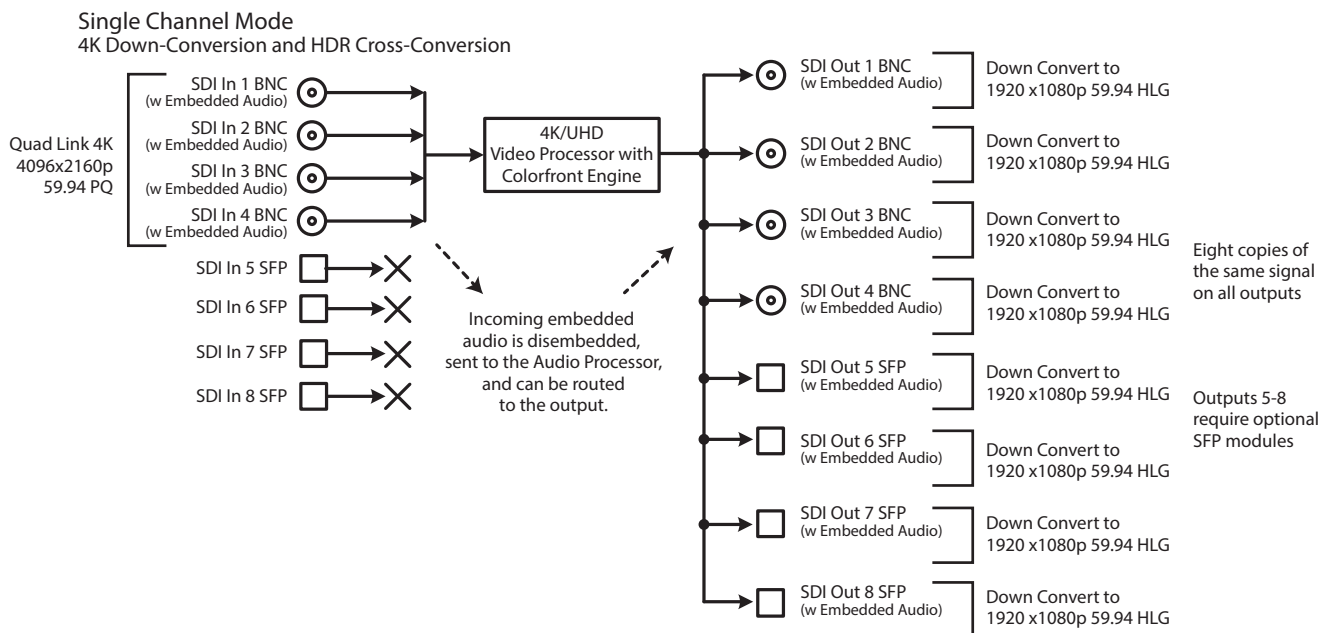

Table 2. Menu Settings for Single Channel Mode, Down and Cross Conversion

Channel Select Button	Video Button	Menu Name	Setting
VID1	INPUT	1 Input	1-4 QuadLink
VID1	INPUT	2.1 Dynamic Range&Gamut	PQ BT.2020 1000Nits
VID1	FORMAT	1 Output Format	1080p5994
VID1	FORMAT	2.1 Dynamic Range&Gamut	Hybrid Log Gamma BT.2100
VID1	FORMAT	3.0 Link Cfg SDI1-4	Sngl Link LvIA
VID1	FORMAT	4.0 Link Cfg SDI5-8	Sngl Link LvIA

Setup

- Ensure the FS-HDR is receiving a valid reference signal. Connect a 1080p 59.94 HD tri-level sync signal to one of the Ref Loop BNC connectors, and terminate the other Ref Loop BNC connector.
- Connect a Quad Link 4K 59.94 signal to the FS-HDR SDI 1, 2, 3, and 4 video input BNC connectors.
- Connect any one of the FS-HDR SDI BNC output connectors to a compatible HDR video monitor.
- Ensure the FS-HDR Vid (n) FORMAT 2.2 *Dynamic Range Clamp* parameter is set to *No Clamp* (default).

Procedure

System Configuration

1. If the FS-HDR is not already in Single Channel Mode, press the *CONFIG* System button:
 - Select 2 *FS-HDR Mode*, select *4K/UHD* and press the ADJUST knob. Wait for the FS-HDR to reboot (not longer than 90 seconds).
2. Press the *VIDEO* System button
 - Select 1 *Output Frame Rate*, and adjust to *59/29/23*.
 - Select 2 *Genlock Source*, and adjust to *Reference*.

Video Processor Setup

3. Press the *VID1* Channel Select button
4. Press the *INPUT* Video button
 - Select 1 *Input*, and adjust to *1-4 QuadLnk*.
 - Select 2.1 *Dynamic Range&Gamut*, and select *PQ BT.2020 1000Nits*.
5. Press the *FORMAT* Video button.
 - Select 1 *Output Format*, and adjust to *1080p5994*.
 - Select 2.1 *Dynamic Range&Gamut*, and select *Hybrid Log Gamma BT.2100*.
 - Select 3.0 *Link Cfg SDI1-4* and adjust to *Sngl Lnk LvIA*.
6. If you have optional SFP output modules installed, you can select *FORMAT 4.0 Link Cfg SDI5-8* and adjust to *Sngl Lnk LvIA* for an additional copy of that converted signal.

The down-converted HD signal should now be present on the connected HDR video monitor.

Multiple Legacy Device SDR To HDR Live Conversion

The following workflow demonstrates simultaneously converting multiple legacy device SD and HD signals for an HD HDR production. In this example, signals from two legacy SDR HD cameras, a legacy SD Video Replay system, and a legacy SD Character Generator are up-converted or transformed to HLG for a live HDR production. Four Channel mode operation is required.

Figure 6. Four Channel Mode Example, Four Conversions

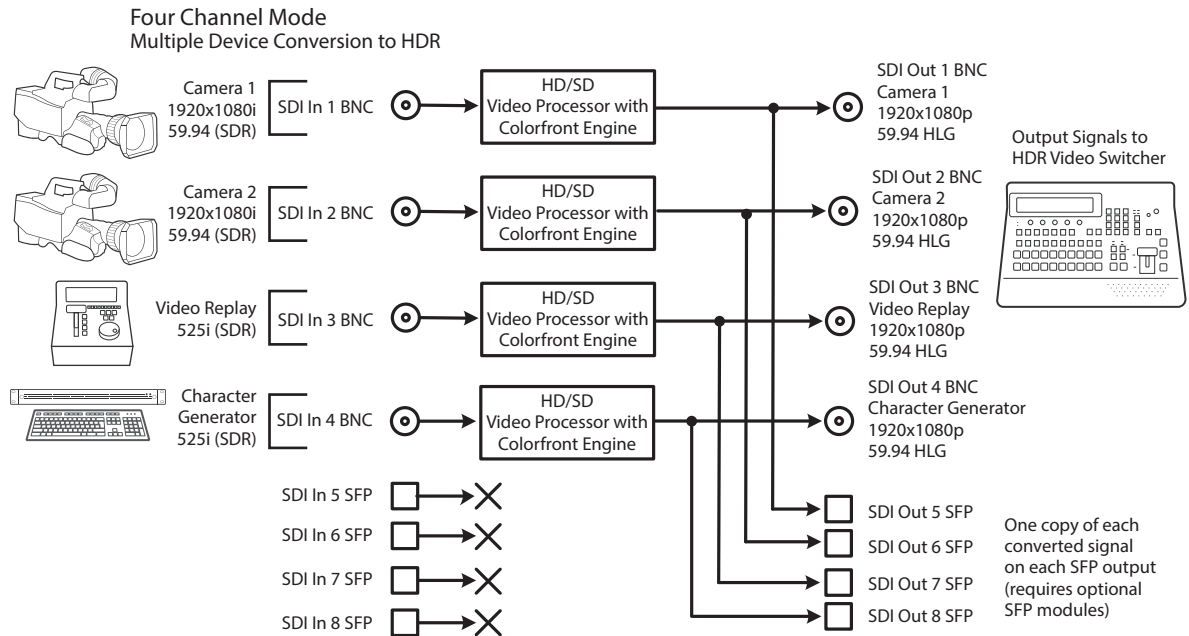

Table 3. Menu Settings for Four Channel Mode Example, Two Conversions

Channel Select Button	Video Button	Menu Name	Setting
VID1	INPUT	1 Input	SDI1
VID1	INPUT	2.1 Dynamic Range&Gamut	SDR BT.709 100 Nits
VID1	INPUT	2.2 SDR Highlights	If necessary, select best image from: Standard (default), Soft 1-3, Bright
VID1	FORMAT	1 Output Format	1080p5994
VID1	FORMAT	2.1 Dynamic Range&Gamut	Hybrid Log Gamma BT.2100
VID1	FORMAT	3.0 Link Cfg SDI1	Sngl Link LvIA
VID1	FORMAT	4.0 Link Cfg SDI5	Sngl Link LvIA
VID2	INPUT	1 Input	SDI2
VID2	INPUT	2.1 Dynamic Range&Gamut	SDR BT.709 100 Nits
VID2	INPUT	2.2 SDR Highlights	If necessary, select best image from: Standard (default), Soft 1-3, Bright
VID2	FORMAT	1 Output Format	1080p5994
VID2	FORMAT	2.1 Dynamic Range&Gamut	Hybrid Log Gamma BT.2100
VID2	FORMAT	3.0 Link Cfg SDI2	Sngl Link LvIA
VID2	FORMAT	4.0 Link Cfg SDI6	Sngl Link LvIA

Channel Select Button	Video Button	Menu Name	Setting
VID3	INPUT	1 Input	SDI3
VID3	INPUT	2.1 Dynamic Range&Gamut	SDR BT.709 100 Nits
VID3	INPUT	2.2 SDR Highlights	If necessary, select best image from: Standard (default), Soft 1-3, Bright
VID3	FORMAT	1 Output Format	1080p5994
VID3	FORMAT	2.1 Dynamic Range&Gamut	Hybrid Log Gamma BT.2100
VID3	FORMAT	3.0 Link Cfg SDI3	Sngl Link LvIA
VID3	FORMAT	4.0 Link Cfg SDI7	Sngl Link LvIA
VID4	INPUT	1 Input	SDI4
VID4	INPUT	2.1 Dynamic Range&Gamut	SDR BT.709 100 Nits
VID4	INPUT	2.2 SDR Highlights	If necessary, select best image from: Standard (default), Soft 1-3, Bright
VID4	FORMAT	1 Output Format	1080p5994
VID4	FORMAT	2.1 Dynamic Range&Gamut	Hybrid Log Gamma BT.2100
VID4	FORMAT	3.0 Link Cfg SDI4	Sngl Link LvIA
VID4	FORMAT	4.0 Link Cfg SDI8	Sngl Link LvIA

Setup

- Ensure the FS-HDR is receiving a valid reference signal. Connect a 1080i59.94 HD tri-level sync signal to one of the Ref Loop BNC connectors, and terminate the other Ref Loop BNC connector.
- Configure the source devices to the desired settings and connect them to SDI1 through SDI 4 BNC inputs on the rear of the FS-HDR. Once connected the LED below the VID1 button on the FS-HDR front panel will light.
- Connect the FS-HDR SDI1 through SDI4 BNC output connectors to a HDR compatible video switcher.
- Ensure the FS-HDR Vid (n) FORMAT 2.2 *Dynamic Range Clamp* parameter is set to *No Clamp* (default).
- View the FS-HDR SDI output signal on a compatible HDR display.

Procedure

System Configuration

1. If the FS-HDR is not already in Four Channel Mode, press the *CONFIG* System button:
 - Select 2 *FS-HDR Mode*, select *HD/SD* and press the ADJUST knob. Wait for the FS-HDR to reboot (not longer than 90 seconds).
2. Press the *VIDEO* System button.
 - Select 1 *Output Frame Rate*, and adjust to 59/29/23.
 - Select 2 *Genlock Source*, and adjust to *Reference*.

Video Processor 1 Setup

3. Press the *VID1* Channel Select button
4. Press the *INPUT* Video button
 - Select 1 *Input*, and adjust to *SDI1*.
 - Select 2.1 *Dynamic Range&Gamut*, and select *SDR BT.709 100 Nits*.

5. Press the *FORMAT* Video button.
 - Select *1 Output Format*, and adjust to *1080p5994*.
 - Select *2.1 Dynamic Range&Gamut*, and select *Hybrid Log Gamma BT.2100*.
6. Press the *INPUT* Video button
 - Select *2.2 SDR Highlights* and select for best image from: *Standard* (default), *Soft 1-3*, or *Bright*.

NOTE: The *SDR Highlights* parameter is only active when transforming from *SDR* to *HDR*. Source *SDR* video dynamic range compression can vary, and only be visible when expanded to *HDR*. This parameter offers five different presets that can be used to try to match the source material. For lesser quality *SDR* video that exhibits substantial clipping, a less aggressive expansion is a better choice. The *Soft 1* to *3* settings are progressively less aggressive.

7. If you have optional SFP output modules installed, you can select *FORMAT 3.0 Link Cfg SDI5* and adjust to *Sngl Lnk LvIA* for an additional copy of that converted signal.

Video Processor 2, 3, and 4 Setup

8. Press the *VID2, 3 or 4 Channel Select* button.
9. Repeat the Video Processor 1 setup steps described above, substituting *2/6*, *3/7*, and *4/8* as appropriate.

The video switcher should now be able to accept all the converted to HLG signals.

Multiple Simultaneous HDR and SDR Distribution

The following workflow demonstrates simultaneously distributing HDR and SDR content. In this example, the FS-HDR converts one HDR input to a different HDR format output and also converts it to an SDR output. Simultaneously the FS-HDR also converts two other signals, one from a BNC input, and the other from an SFP module input. Four Channel mode operation is required.

Figure 7. Four Channel Mode Example, Four Conversions of Three Sources

Four Channel Mode
Simultaneous HDR and SDR Distribution

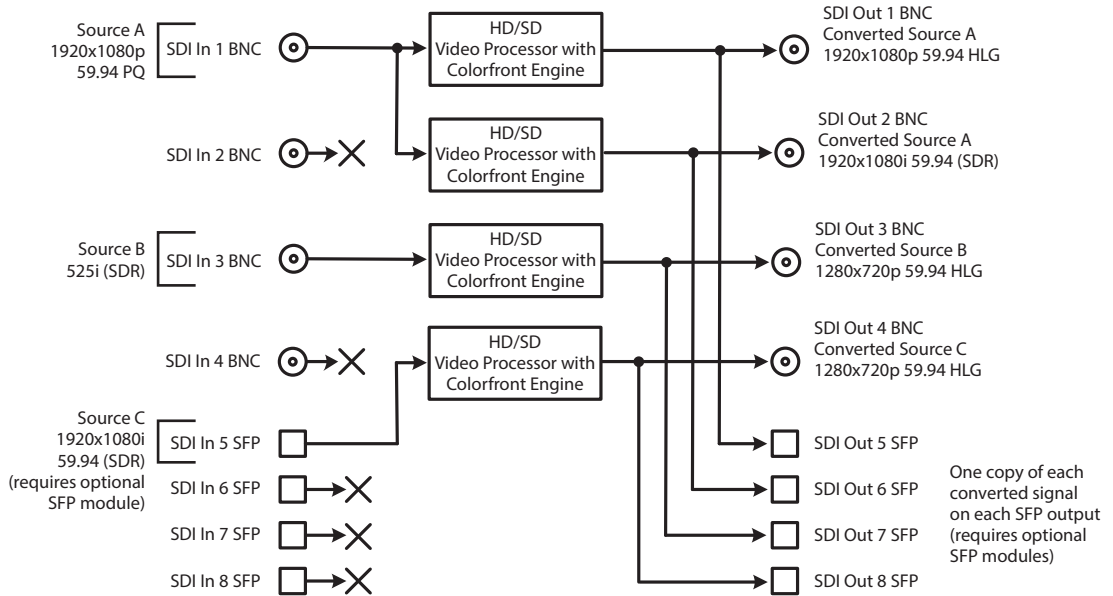

Table 4. Menu Settings for Four Conversions of Three Sources

Channel Select Button	Video Button	Menu Name	Setting
VID1	INPUT	1 Input	SDI1
VID1	INPUT	2.1 Dynamic Range&Gamut	PQ BT.2020 1000 Nits
VID1	FORMAT	1 Output Format	1080p5994
VID1	FORMAT	2.1 Dynamic Range&Gamut	Hybrid Log Gamma BT.2100
VID1	FORMAT	3.0 Link Cfg SDI1	Sngl Link LvIA
VID1	FORMAT	4.0 Link Cfg SDI5	Sngl Link LvIA
VID2	INPUT	1 Input	SDI1
VID2	INPUT	2.1 Dynamic Range&Gamut	PQ BT.2020 1000 Nits
VID2	FORMAT	1 Output Format	1080i5994
VID2	FORMAT	2.1 Dynamic Range&Gamut	SDR BT.709 100 Nits
VID2	FORMAT	3.0 Link Cfg SDI2	Sngl Link LvIA
VID2	FORMAT	4.0 Link Cfg SDI6	Sngl Link LvIA
VID3	INPUT	1 Input	SDI3
VID3	INPUT	2.1 Dynamic Range&Gamut	SDR BT.709 100 Nits
VID3	INPUT	2.2 SDR Highlights	If necessary, select best image from: Standard (default), Soft 1-3, Bright
VID3	FORMAT	1 Output Format	720p5994
VID3	FORMAT	2.1 Dynamic Range&Gamut	Hybrid Log Gamma BT.2100
VID3	FORMAT	3.0 Link Cfg SDI3	Sngl Link LvIA
VID3	FORMAT	4.0 Link Cfg SDI7	Sngl Link LvIA
VID4	INPUT	1 Input	SDI5
VID4	INPUT	2.1 Dynamic Range&Gamut	SDR BT.709 100 Nits
VID4	INPUT	2.2 SDR Highlights	If necessary, select best image from: Standard, Soft 1-3, Bright
VID4	FORMAT	1 Output Format	720p5994
VID4	FORMAT	2.1 Dynamic Range&Gamut	Hybrid Log Gamma BT.2100
VID4	FORMAT	3.0 Link Cfg SDI4	Sngl Link LvIA
VID4	FORMAT	4.0 Link Cfg SDI8	Sngl Link LvIA

Setup

- Ensure the FS-HDR is receiving a valid reference signal. Connect a 1080i59.94 HD tri-level sync signal to one of the Ref Loop BNC connectors, and terminate the other Ref Loop BNC connector.
- Connect sources A and B to the FS-HDR SDI 1 and SDI 3 Input BNCs.
- Install an optional SFP module into the FS-HDR SDI 5 Input cage and connect the source cable.
- Connect the FS-HDR SDI outputs to the downstream devices.
- Ensure the FS-HDR Vid (n) FORMAT 2.2 *Dynamic Range Clamp* parameter is set to *No Clamp* (default).
- View the FS-HDR SDI output signals on a compatible HDR or SDR display.

Procedure

System Configuration

1. If the FS-HDR is not already in Four Channel Mode, press the *CONFIG* System button:
 - Select 2 *FS-HDR Mode*, select *HD/SD* and press the ADJUST knob. Wait for the FS-HDR to reboot (not longer than 90 seconds).
2. Press the *VIDEO* System button
 - Select 1 *Output Frame Rate*, and adjust to *59/29/23*.
 - Select 2 *Genlock Source*, and adjust to *Reference*.

Video Processor 1 Setup

3. Press the *VID1* Channel Select button.
4. Press the *INPUT* Video button.
 - Select 1 *Input*, and adjust to *SDI1*.
 - Select 2.1 *Dynamic Range&Gamut*, and select *PQ BT.2020 1000 Nits*.
5. Press the *FORMAT* Video button.
 - Select 1 *Output Format*, and adjust to *1080p5994*.
 - Select 2.1 *Dynamic Range&Gamut*, and select *Hybrid Log Gamma BT.2100s*
6. If you have optional SFP output modules installed, you can select *FORMAT 3.0 Link Cfg SDI5* and adjust to *Sngl Lnk LvIA* for an additional copy of that converted signal.

Video Processor 2 Setup

7. Press the *VID2* Channel Select button.
8. Press the *INPUT* Video button.
 - Select 1 *Input*, and adjust to *SDI1* (same input as Video Processor 1).
 - Select 2.1 *Dynamic Range&Gamut*, and select *PQ BT.2020 1000 Nits*.
9. Press the *FORMAT* Video button.
 - Select 1 *Output Format*, and adjust to *1080p5994*
 - Select 2.1 *Dynamic Range&Gamut*, and select *SDR BT.709 100 Nits*.
10. If you have optional SFP output modules installed, you can select *FORMAT 3.0 Link Cfg SDI6* and adjust to *Sngl Lnk LvIA* for an additional copy of that converted signal.

Video Processor 3 Setup

11. Press the *VID3* Channel Select button.
12. Press the *INPUT* Video button.
 - Select 1 *Input*, and adjust to *SDI3*.
 - Select 2.1 *Dynamic Range&Gamut*, and select *SDR BT.709 100 Nits*.
13. Press the *FORMAT* Video button.
 - Select 1 *Output Format*, and adjust to *720p5994*.
 - Select 2.1 *Dynamic Range&Gamut*, and select *Hybrid Log Gamma BT.2100*.
14. Press the *INPUT* Video button
 - Select 2.2 *SDR Highlights* and select for best image from: Standard (default), Soft 1-3, or Bright.
15. If you have optional SFP output modules installed, you can select *FORMAT 3.0 Link Cfg SDI7* and adjust to *Sngl Lnk LvIA* for an additional copy of that converted signal.

16. Press the *VID4* Channel Select button.
17. Press the *INPUT* Video button.
 - Select *1 Input*, and adjust to *SDIS*.
 - Select *2.1 Dynamic Range&Gamut*, and select *SDR BT.709 100 Nits*.
18. Press the *FORMAT* Video button.
 - Select *1 Output Format*, and adjust to *720p5994*.
 - Select *2.1 Dynamic Range&Gamut*, and select *Hybrid Log Gamma BT.2100*.
19. Press the *INPUT* Video button
 - Select *2.2 SDR Highlights* and select for best image from: Standard (default), Soft 1-3, or Bright.
20. If you have optional SFP output modules installed, you can select *FORMAT 3.0 Link Cfg SDI8* and adjust to *Sngl Lnk LvIA* for an additional copy of that converted signal.