

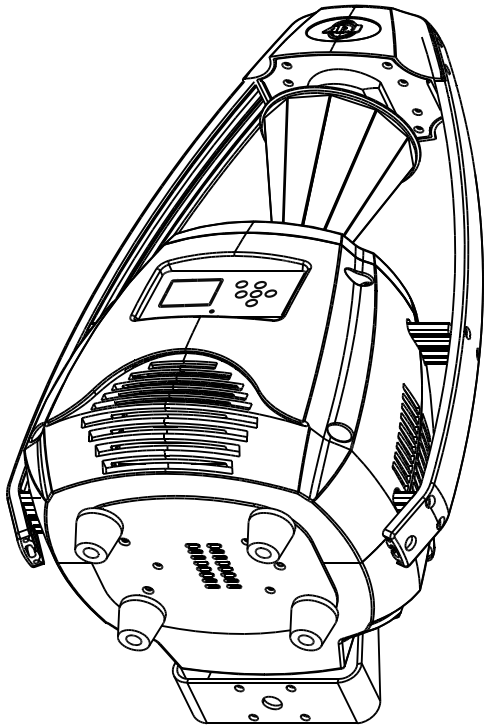



# VIZI ROLLER BEAM 2R



## User Instructions

©2014 ADJ Products, LLC all rights reserved. Information, specifications, diagrams, images, and instructions herein are subject to change without notice. ADJ Products, LLC logo and identifying product names and numbers herein are trademarks of ADJ Products, LLC. Copyright protection claimed includes all forms and matters of copyrightable materials and information now allowed by statutory or judicial law or hereinafter granted. Product names used in this document may be trademarks or registered trademarks of their respective companies and are hereby acknowledged. All non-ADJ Products, LLC brands and product names are trademarks or registered trademarks of their respective companies.

ADJ Products, LLC and all affiliated companies hereby disclaim any and all liabilities for property, equipment, building, and electrical damages, injuries to any persons, and direct or indirect economic loss associated with the use or reliance of any information contained within this document, and/or as a result of the improper, unsafe, insufficient and negligent assembly, installation, rigging, and operation of this product.

 C REGISTERED US	CONFORMS TO UL STD. 1573 CERTIFIED TO CSA STD. C22.2 NO:166 MODEL:VIZI ROLLER BEAM 2R 100-240VAC,50/60Hz; 210W MAX; TYPE: PLATINUM 2R 135W MAX Made in PRC MANUFACTURING DATE: _____	<b>WARNING</b> <ul style="list-style-type: none"><li>• Not for Residential Use.</li><li>• NOT FOR HOUSEHOLD USE</li><li>• IMPROPRE A L'USAGE DOMESTIQUE</li><li>• DRY LOCATIONS EMBLEMENTS SECS</li></ul>
	<b>Intertek</b> 4010832	<ul style="list-style-type: none"><li>• <b>DANGER: Intense Heat. Avoid Contact by Persons and Materials.</b> DANGER: Chaleur intense. Évitez le contact avec les personnes et les matériaux.</li><li>• <b>CAUTION: Risk of exposure to excessive ultraviolet(UV) radiation- Do not operate without complete lamp enclosure in place or when (glass) lens is damaged.</b> ATTENTION: Risque d'exposition excessive aux rayons ultraviolets (UV)-Ne pas faire fonctionner sans s'assurer que la lampe est complètement en place ou lorsque la lentille (verre) est endommagée.</li><li>• <b>WARNING: Risk of possible lamp explosion. Service and maintenance should be performed only by qualified personnel determined by the high-pressure luminaire manufacturer. Protective clothing and procedures as outlined in the as dealer manufacturer's manual must be followed.</b> AVERTISSEMENT: Risque d'explosion possible de la lampe. Le service et l'entretien devraient être exécutés seulement par du personnel qualifié et autorisés par le fabricant d'appareil d'éclairage à haute pression. Des vêtements de protection et des procédures adéquates doivent être suivis conformément au manuel du fabricant.</li><li>• <b>CAUTION: Use only a high-pressure lamp of the proper size and type in this lamp system.</b> ATTENTION: Utilisez uniquement une lampe à haute pression, de taille et de type approprié à ce système lampe.</li><li>• <b>CAUTION: Serious injury may result from the generation of ozone by this lamp system. A proper means of venting must be provided.</b> ATTENTION: Des blessures sérieuses pourraient résulter de la production d'ozone par ce système de lampe. Un bon système de ventilation doit être en place.</li><li>• <b>Warning: the same type can be linked.</b> Avertissement: le même type peut être lié.</li><li>• <b>Use replacement fuses rated at 3.15 Amperes, and 250 Volts.</b> Utilisez des fusibles de remplacement d'une puissance de 3.15 ampères et 250 volts.</li></ul>

### Europe Energy Saving Notice

#### Energy Saving Matters (EuP 2009/125/EC)

Saving electric energy is a key to help protecting the environment. Please turn off all electrical products when they are not in use. To avoid power consumption in idle mode, disconnect all electrical equipment from power when not in use. Thank you!

# Table of Contents

Unpacking.....	3
Introduction.....	3
Customer Support.....	3
Safety Precautions.....	4
Features.....	5
Handling Precautions.....	6
Registration.....	6
Important Discharge Lamp Warnings.....	7
Mounting.....	8
Controls and Functions.....	10
DMX Set-Up.....	13
System Menu.....	16
Error Codes.....	37
Operation.....	39
DMX Traits.....	41
Lamp Replacement.....	53
Fuse Replacement.....	53
Photometric Chart.....	54
Cleaning.....	55
Trouble Shooting.....	55
Warranty.....	56
Specifications.....	58

Please see page 7 for important lamp instructions!

## Vizi Roller Beam 2R

## General Information

**Unpacking:** Thank you for purchasing the Vizi Roller Beam 2R by ADJ Products, LLC. Every Vizi Roller Beam 2R has been thoroughly tested and has been shipped in perfect operating condition. Carefully check the shipping carton for damage that may have occurred during shipping. If the carton appears to be damaged, carefully inspect your fixture for any damage and be sure all equipment necessary to operate the unit has arrived intact. In the event damage has been found or parts are missing, please contact our toll free customer support number for further instructions. Please do not return this unit to your dealer without contacting customer support first.

**Introduction:** The Vizi Roller Beam 2R is a DMX intelligent, unique cone barrel scanner. The Vizi Roller Beam 2R can be a 11 channel, 13 channel, or 18 Channel DMX unit. The fixture can has three different operating modes; show mode, sound-active, or DMX control. The Vizi Roller Beam 2R can be used as a stand alone unit or in a master/slave configuration. *For best results use fog or special effects smoke to enhance the beams projections.*

**During the initial start-up or use of this product a light smoke or smell may arise from the unit. This is a normal process and is cause by the heat associated with the lamp.**

**Customer Support:** ADJ Products, LLC provides a toll free customer support line, to provide help and to answer any question should you encounter problems during your set up or initial operation. You may also visit us on the web at [www.adj.com](http://www.adj.com) for any comments or suggestions. Service Hours are Monday through Friday 8:00 a.m. to 4:30 p.m. Pacific Standard Time.

Voice: (800) 322-6337  
 Fax: (323) 582-2610  
 E-mail: [support@americandj.com](mailto:support@americandj.com)

**Warning!** To prevent or reduce the risk of electrical shock or fire, do not expose this unit to rain or moisture.

**Warning!** *This may cause severe eye damage. Avoid looking directly into the light source at all times!*

## Vizi Roller Beam 2R

## Safety Precautions

***For Your Own Personal Safety, Please Read and Understand This Manual Completely Before You Attempt To Install Or Operate This Unit!***

- To reduce the risk of electrical shock or fire, do not expose this unit rain or moisture
- Do not spill water or other liquids into or on to your unit.
- Be sure that the local power outlet match that of the required voltage for your unit.
- Do not attempt to operate this unit if the power cord has been frayed or broken.
- Do not attempt to remove or break off the ground prong from the electrical cord. This prong is used to reduce the risk of electrical shock and fire in case of an internal short.
- Disconnect from main power before making any type of connection.
- Do not remove the cover under any conditions. There are no user serviceable parts inside.
- Never operate this unit when it's cover is removed.
- Always be sure to mount this unit in an area that will allow proper ventilation. Allow about 6" (15cm) between this device and a wall.
- Do not attempt to operate this unit, if it becomes damaged.
- This unit is intended for indoor use only, use of this product outdoors voids all warranties.
- Always mount this unit in safe and stable matter.
- Power-supply cords should be routed so that they are not likely to be walked on or pinched by items placed upon or against them, paying particular attention to cords at plugs, convenience receptacles, and the point where they exit from the appliance.
- Cleaning -The fixture should be cleaned only as recommended by the manufacturer. See page 55 for cleaning details.
- Heat -This fixture should be situated away from heat sources such as radiators, heat registers, stoves, or other appliances (including amplifiers) that produce heat.
- The fixture should be serviced by qualified service personnel when:
  - A. Objects have fallen, or liquid has been spilled into the appliance.
  - B. The appliance has been exposed to rain or water.
  - C. The appliance does not appear to operate normally or exhibits a marked change in performance.

## Vizi Roller Beam 2R

## Features

- Micro-Stepping Motors for Smooth Color and Gobo Transitions
- 3 DMX Channel Modes (11 DMX Channel Mode, 13 DMX Channel Mode, and 18 DMX Channel Mode)
- Independent Gobo and Color Wheels
- 8 Gobos + 6 Spots
- 13 Colors + White - With Rainbow
- 3 Operating Modes - Sound Active, Auto Program, and DMX Controlled.
- Master/Slave Configuration or Stand Alone Set Up
- Internal Microphone
- Philips® Platinum MSD 2R Discharge
- Edit and Save Scenes into the Memory
- 315° Pan Movement/ 90° Tilt Movement + 360° Barrel Rotation
- Digital Display for Address and Function Setting

## Vizi Roller Beam 2R

## General Instructions

To optimize the performance of this product, please read these operating instructions carefully to familiarize yourself with the basic operations of this unit. These instructions contain important safety information regarding the use and maintenance of this unit. Please keep this manual with the unit, for future reference.

## Vizi Roller Beam 2R

## Handling Precautions

**Caution!** There are no user serviceable parts inside this unit. Do not attempt any repairs yourself, doing so will void your manufacturer's warranty. In the unlikely event your unit may require service please contact ADJ Products, LLC.

*During operation the housing may become extremely hot. Avoid touching the unit with bare hands while in use.*

*ADJ Products, LLC will not accept any liability for any resulting damages caused by the non-observance of this manual or any unauthorized modification to this unit.*

## Vizi Roller Beam 2R

## Product Registration

The Vizi Roller Beam 2R carries a one year limited warranty. Please fill out the enclosed warranty card to validate your purchase. All returned service items whether under warranty or not, must be freight pre-paid and accompany a return authorization (R.A.) number. The R.A. number must be clearly written on the outside of the return package. A brief description of the problem as well as the R.A. number must also be written down on a piece of paper and included in the shipping carton. If the unit is under warranty, you must provide a copy of your proof of purchase invoice. You may obtain a R.A. number by contacting our customer support team on our toll free customer support number. All packages returned to the service department not displaying a R.A. number on the outside of the package will be returned to the shipper at the shipper's cost.

## Vizi Roller Beam 2R Important Discharge Lamp Warning

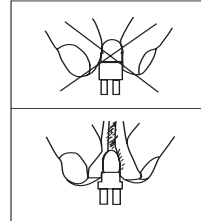

This fixture is fitted with a discharge lamp which is highly susceptible to damage if improperly handled. Never touch the lamp with your bare fingers as the oil from your hands will shorten lamp life. Also, never move the fixture until the lamps have had ample time to cool. Remember, lamps are not covered under warranty conditions.

This unit emits intense UV radiation which is harmful to the eyes and skin. The intense luminance of the lamp can cause severe damage to the retina. Never operate this unit without its covers, these covers have been specially designed to shield against UV radiation.

**Epileptic Warning:** Those suffering from epilepsy should avoid looking directly into the lamp at all times.

Avoid switching the fixture on and off repeatedly in short intervals as this will reduce lamp life and intensity.

To achieve the intensity associated with discharge lamps, these lamps use gas sealed in a high pressure environment to emit a brilliant output. Due to the high pressure involved with the construction of the lamp, the lamp may explode during prolonged extensive use. This risk is increased with age, added care is encouraged when dealing with older lamps. Extreme caution should be used when operating this or any fixture fitted with a gas discharge lamp. Never open this unit while in use.

**VERY IMPORTANT:** This is for your safety and the life length of the unit. The Philips® Platinum 2R Discharge lamp has lifetime of 6,000 hours.

Because of the nature of the extreme heat associated with the Platinum 2R lamp and the tight nature of the internal optical system it is imperative that the lamp be replaced every 6000 hours. This is done to protect the internal optical system as well as prevent accidental lamp explosion, which could lead to hot glass particles falling from the fixture. Failure to change the lamp within 300 hours of operation will result in automatic shut down of the fixture's electronics.

At 6000 hours the display will begin to flash "Replace The Lamp" and the lamp will flicker for the first five minutes of operation. At this point the lamp has reached the maximum rated life and should be replaced immediately. After the lamp has flickered for about five minutes it should strike normally allowing the fixture to be used temporarily until a replacement lamp can be installed. The fixture will continue to operate for an additional 300 hours, however the "Replace the Lamp" warning will continue to flash in the display. Keep in mind that the flicker protection circuitry will only work for about 300 hours (lamp clock life of 6000-6300 hours). After 6300 hours the fixture will no longer respond to DMX commands and immediately enter a hibernation mode that will electronically discontinue all fixture functionality with the exception of a few menu commands. The fixture will continue to enter hibernation mode until the lamp is replaced and the lamp clock has been reset. See page 22 to Clear the lamp time.

## Vizi Roller Beam 2R

## Mounting

When installing the unit, the trussing or area of installation must be able to hold 10 times the weight without any deformation. When installing the unit must be secured with a secondary safety attachment, e.g. an appropriate safety cable. Never stand directly below the unit when mounting, removing, or servicing the unit.

Overhead mounting requires extensive experience, including calculating working load limits, installation material being used, and periodic safety inspection of all installation material and unit. If you lack these qualifications, do not attempt the installation yourself.

These installaiton should be checked by a skilled person once a year.

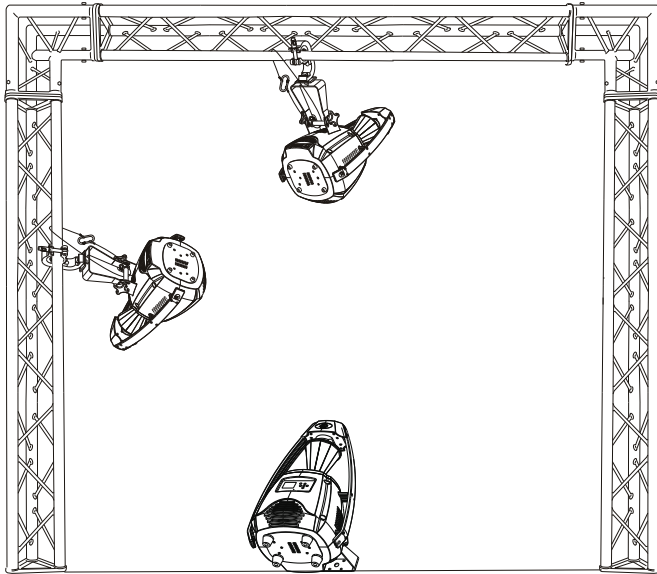

The Vizi Roller Beam 2R is fully operational in three different mounting positions, hanging upside-down from a ceiling, mounted sideways, or set on a flat level surface. Be sure this fixture is kept at least 0.5m away from any flammable materials (decoration etc.). Always use and install the supplied safety cable as a safety measure to prevent accidental damage and/or injury in the event the clamp fails (see next page). Never use the carrying handles for secondary attachment.

## Vizi Roller Beam 2R

## Mounting

**NOTICE:** The suitable enviromental temperature for this lighting fixture is between  $-25^{\circ}\text{C}$  to  $45^{\circ}\text{C}$ . Do not place this lighting fixture in an enviroment where the temperatures are under or above the temperatures stated above. This will allow the fixture to run at its best and help prolong the fixture life.

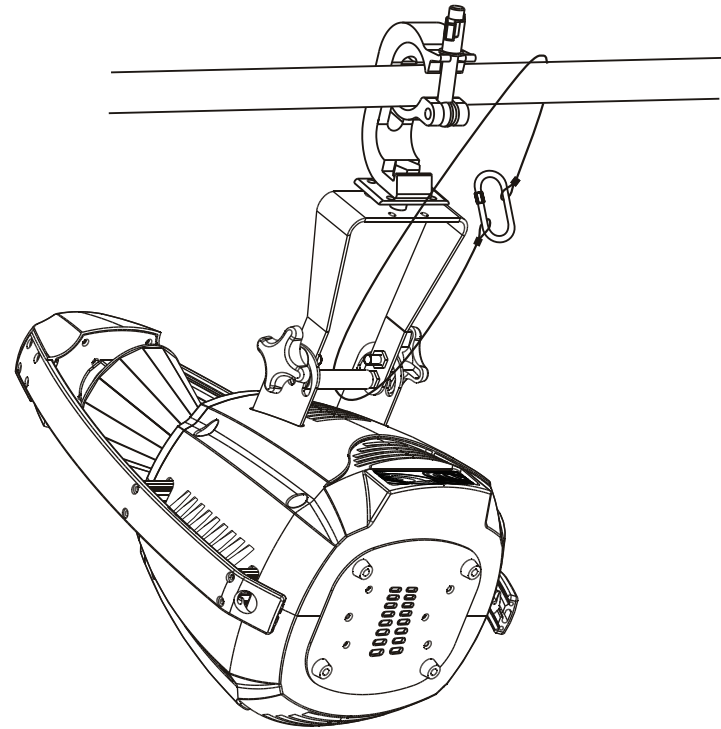

Screw one clamp each via a M12 screw and nut onto the Omega holders. Insert the quick-lock fasteners of the first Omega holder into the respective holes on the bottom of the Vizi Roller Beam 2R. Tighten the quick-lock fasteners fully clockwise. Install the second Omega holder. Pull the safety-cable through the holes on the bottom of the base and over the trussing system or a safe fixation spot. Insert the end in the carabine and tighten the safety screw.



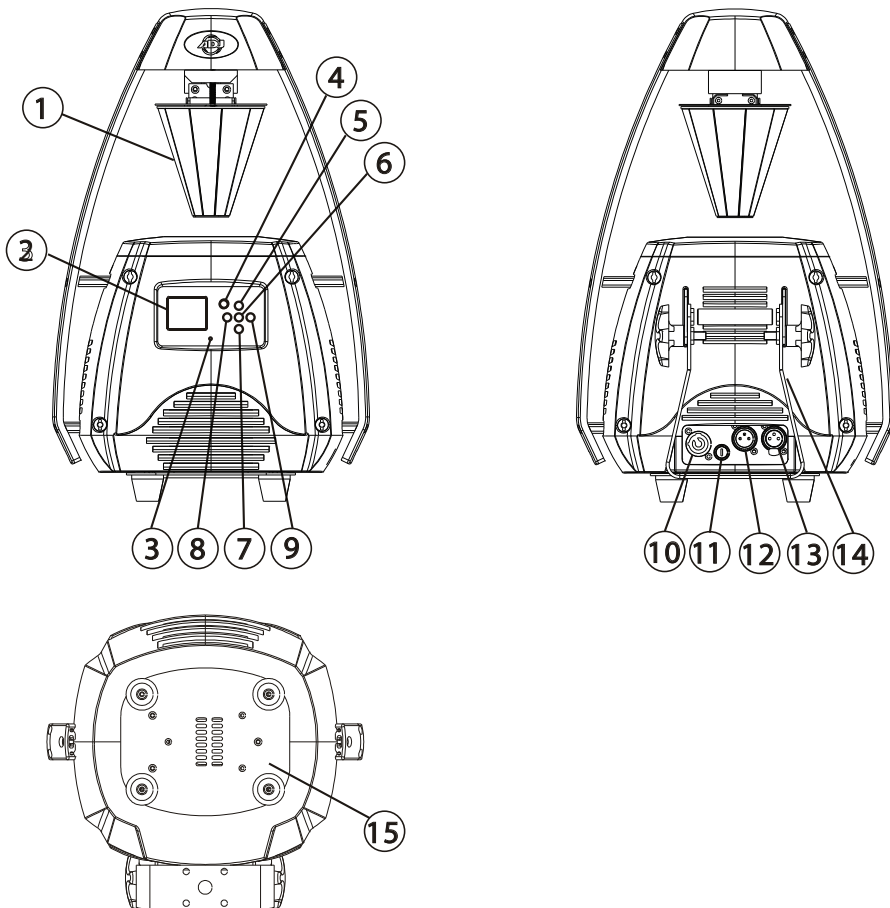

**1. Cone Barrel Mirror** - This is a highly reflective surface mirror specifically designed to optimize and enhance beam output. Never use glass cleaner that contain ammonia to clean the surface of the mirror (such as Windex).

**2. Digital Display** - This display shows the menu and operating functions that you can choose from.

**3. Microphone** - This microphone receives external low frequencies to trigger the unit in Sound-Active mode. This microphone is designed to receive low frequency sounds only, tapping on the microphone and high pitch sounds may not trigger the unit.

**4. Mode/Esc Button** - This button is used to enter the main menu and submenus. It is also used to exit.

**5. Up Button** - This button is used to scroll forwards when navigating through the system menu.

**6. Enter Button** - This button is used to select and confirm a function in the system menu.

**7. Down Button** - This button is used to scroll backwards when navigating through the system menu.

**8. Left Button** - This button is used to move to the left when navigating through the system menu.

**9. Right Button** - This button is used to move to the right when navigating through the system menu.

**10. Power Cord Inlet** - This cord is designed to match the electrical requirements of the unit. Voltage may vary from venue to venue, when connecting this unit to a power supply be sure to connect to a matching power outlet. Never use this fixture if the ground prong has been removed or broken off. The ground prong is designed to reduce the risk of fire or electrical shock in the event the unit suffers from an internal short.

**11. Fuse Holder** - This housing stores a 4 amp protective fuse. Never defeat the fuse, the fuse is designed to protect the electronics in the event of severe power fluctuations. Always be sure to replace the fuse with an exact match as the one being replaced, unless otherwise told to do so by an authorized ADJ service technician.

**12. XLR DMX Input Jack** - This jack is used to receive an incoming DMX signal or Master/Slave signal.

**13. XLR Output Jack** - This jack is used to transmit the incoming DMX signal to another DMX fixture, or transmit a Master/Slave signal to the next Vizi Roller Beam 2R in the chain. For best results in DMX or Master/Slave mode terminate this jack if it is the last unit in the chain. See “Line Termination” on page 14.

**14. Carrying Handles** - The includes built-in carrying handles. Be sure to always handle the unit by the built-in handles. Never lift or carrying the unit by head or yoke. Pulling on or transporting the unit by the moving head may severely damage the unit and will void the unit warranty.

**15. Lamp Assembly and Access Plate** - This plate accesses the lamp socket assembly. The unit includes a spring mounted discharge lamp. Be sure to only replace with same type lamp. After replacing a lamp be sure the lamp is centered in the reflector. See pages 52-53 for details on installing and optimizing replacement lamps. Never operate this unit with the lamp exposed, this lamp emits strong UV radiation. Please see page 7 for important information about the Philips® Platinum 5R discharge lamp.

**Power Supply:** The ADJ Vizi Roller Beam 2R contains a electronic ballast, which will auto sense the voltage when it is plugged into the power source. With the electronic ballast you do not need to worry about wall voltage, this unit can be plugged in anywhere.

**DMX-512:** *DMX is short for Digital Multiplex. This is a universal protocol used by most lighting and controller manufactures as a form of communication between intelligent fixtures and controllers. A DMX controller sends DMX data instructions from the controller to the fixture. DMX data is sent as serial data that travels from fixture to fixture via the DATA “IN” and DATA “OUT” XLR terminals located on all DMX fixtures (most controllers only have a DATA “OUT” terminal).*

**DMX Linking:** DMX is a language allowing all makes and models of different manufactures to be linked together and operate from a single controller, as long as all fixtures and the controller are DMX compliant. *To ensure proper DMX data transmission, when using several DMX fixtures try to use the shortest cable path possible. The order in which fixtures are connected in a DMX line does not influence the DMX addressing. For example; a fixture assigned a DMX address of 1 may be placed anywhere in a DMX line, at the beginning, at the end, or anywhere in the middle. Therefore, the first fixture controlled by the controller could be the last fixture in the chain. When a fixture is assigned a DMX address of 1, the DMX controller knows to send DATA assigned to address 1 to that unit, no matter where it is located in the DMX chain.*

**Data Cable (DMX Cable) Requirements (For DMX and Master/Slave Operation):**

The Vizi Roller Beam 2R can be controlled via DMX-512 protocol. The Vizi Roller Beam 2R can be either a 11, 13, or 18 channel DMX unit. The DMX address is set electronically using the controls on the front panel of the unit. Your unit and your DMX controller require a approved DMX-512 110 Ohm Data cable for data input and data output (Figure 1). We recommend Accu-Cable DMX cables. If you are making your own cables, be sure to use standard 110-120 Ohm shielded cable (This cable may be purchased at almost all professional sound and lighting stores). Your cables should be made with a male and female XLR connector on either end of the cable. Also



Figure 1

remember that DMX cable must be daisy chained and cannot be split.

**Notice:** Be sure to follow figures two and three when making your own cables. Do not use the ground lug on the XLR connector. Do not connect the cable’s shield conductor to the ground lug or allow the shield conductor to come in contact with the XLR’s outer casing. Grounding the shield could cause a short circuit and erratic behavior.

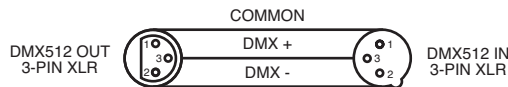

Figure 2

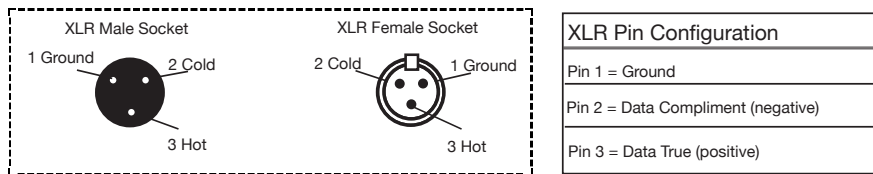

Figure 3

**Special Note: Line Termination.** When longer runs of cable are used, you may need to use a terminator on the last unit to avoid erratic behavior. A terminator is a 110-120 ohm 1/4 watt resistor which is connected between pins 2 and 3 of a male XLR connector (DATA + and DATA -). This unit is inserted in the female XLR connector of the last unit in your daisy chain to terminate the line. Using a cable terminator (ADJ part number Z-DMX/T) will decrease the possibilities of erratic behavior.



Termination reduces signal errors and avoids signal transmission problems and interference. It is always advisable to connect a DMX terminal. (Resistance 120 Ohm 1/4 W) between PIN 2 (DMX-) and PIN 3 (DMX +) of the last fixture.

Figure 4

**5-Pin XLR DMX Connectors.** Some manufactures use 5-pin DMX-512 data cables for DATA transmission in place of 3-pin. 5-pin DMX fixtures may be implemented in a 3-pin DMX line. When inserting standard 5-pin data cables in to a 3-pin line a cable adaptor must be used, these adaptors are readily available at most electric stores. The chart below details a proper cable conversion.

3-Pin XLR to 5-Pin XLR Conversion		
Conductor	3-Pin XLR Female (Out)	5-Pin XLR Male (In)
Ground/Shield	Pin 1	Pin 1
Data Compliment (- signal)	Pin 2	Pin 2
Data True (+ signal)	Pin 3	Pin 3
Not Used		Pin 4 - Do Not Use
Not Used		Pin 5 - Do Not Use



Function	Set Dmx Address Dmx Value Slave Mode Auto Program Sound Control	A001~AXXX PAN..... Slave1,Slave2,Slave3 Master / Alone Master / Alone		DMX address setting DMX value display Slave setting Auto program Sound Control	
Information	Time Information	Current Time	XXXX(Hours)	Power on running time	
		Total Run Time	XXXX(Hours)	Fixture running time	
Personality	Status Settings	Last Run Time	XXXX(Hours)	Fixture Last times clear	
		Lamp Hours	XXXX(Hours)	Lamp running time	
		Lamp Off Time	XXXX(Minute)	Lamp off time	
		LastRun Password	Password=XXX	Timer Password 038	
		Clean Last Run	ON/OFF	Clear Fixture Last time	
		LampTime Password	Password=XXX	Lamp Password = "038"	
		Clean Lamp Time	ON/OFF	Clear lamp time	
		Temperature Info	Head Temperature	XXX./°	Temperature in the head
		Software Version	V1.0.....		Software version
		Lamp Control	Lamp On/Off Automatic On Lamp On via DMX Lamp Off via DMX Max On at Temp. Lamp Off Temp.	ON/OFF	
ON/OFF				Lamp on/off Power on	
ON/OFF				Lamp on via DMX	
Personality	Service Setting	ON/OFF		Lamp off via DMX	
		20~79°C, 68~174°F	113°F	Lamp restart at temp.	
		80~139°C, 130°C / 176~282°F	266°F	Lamp off at temp.	
		Address Via DMX	ON/OFF		Add. via DMX
		No DMX Status	Close/Hold/Auto/Music		Auto run if no DMX
		Pan Reverse	ON/OFF		Pan Reverse movement
		Tilt Reverse	ON/OFF		Tilt Reverse movement
		Mic Sensitivity	0~99%		Sensitivity of Mic.
		Hibernation	OFF, 01M~99M, 15M		Stand by Mode
		Personality	Fans Control	Password	Password=XXX
RDM PID	XXXXXX			RDM PID Code	
Auto Fan Speed				Fans Speed select	
Personality	Display Setting	High Fan Speed			
		Low Fan Speed			
		Shutoff Time	02~60m 05m	Display shutoff time	
Personality	Temperature C/F	Display Reverse	ON/OFF	Reverse 180 degree	
		Key Lock	ON/OFF	Key Lock	
		Celsius		Temperature switch	
Personality	Initial Status	Fahrenheit		between /°	
		PAN =XXX		Initial effect position	
		.....			
Personality	Reset Default	ON/OFF		Restore factory set.	
		Reset All		Reset all motors	
		Reset Pan&Tilt		Reset Pan/Tilt	
Personality	Reset Function	Reset Colors		Reset color wheel	
		Reset Gobos		Reset gobos	
		Reset Shutter		Reset shutter or dimmer	
Personality	Reset Others	Reset Others		Reset other motors	
		Test Channel	PAN .....	Test function	
		Manual Control	PAN =XXX :	Fine adjustment of the lamp	
Effect Adjust	Calibration	Calibrate Password		Password "050"	
		Color wheel=XXX		Calbrate and adjust the effects to standard/right position	
		:			
Users Mode Set	User Mode	Standard Mode		User's mode to change channel numbers	
		Basic Mode			
		Extended Mode			
Users Mode Set	Edit User Mode	User Mode A			
		User Mode B			
		User Mode C			
Edit Program	Select Programs	Max Channel = XX		Preset User modes	
		PAN = CH01			
		:			
Edit Program	Edit Program	Auto Pro Part 1 = Program 1 ~ 10	Program 1	Select programs to be run	
		Auto Pro Part 2 = Program 1 ~ 10	Program 2		
		Auto Pro Part 3 = Program 1 ~ 10	Program 3		
Edit Program	Edit Scenes	Program 1	Program Test	Testing program	
		:	Step 01=SCxxx	Program in loop	
		Program 10	Step 64=SCxxx	Save and exit	
Edit Program	Rec. Controller	Pan,Tilt,.....		Save and automatically return manual scenes edit	
		--Fade Time--			
		--Scene Time--			
Edit Program	Rec. Controller	Input By Exterior			
		XX~XX		Automat. scenes rec	

The main menu is accessed by pressing the MODE/ESC button. Browse through the menu by using the UP, DOWN, RIGHT, & LEFT buttons. Press the ENTER button to access the desired menu. You can scroll through the submenus using the UP, DOWN, RIGHT, & LEFT buttons. To confirm every selection press the ENTER button. You can exit every menu and submenu by pressing the MODE/ESC button. The unit will automatically exit the menus if no buttons are pressed after 10 seconds. These next pages will explain each function in the menu layout located on the previous page.

**FUNCTION -**

**Set DMX Address** - With this function, you can adjust the desired DMX-address via the Control Board.  
 1. Access the main menu, and press the UP or DOWN buttons so that **"Function"** is highlighted, then press ENTER.

2. Press the UP or DOWN buttons until **"Set DMX Address"** is displayed, and press ENTER. The current DMX address will now be displayed.
3. Use the UP or DOWN buttons to adjust the DMX address.
4. Press ENTER to confirm or press MODE/ESC to return to the main menu.

**DMX Value** - This function will allow you to see the DMX value of each DMX channel that is currently being used at the time.

1. Access the main menu, and press the UP or DOWN buttons so that **"Function"** is highlighted, then press ENTER.
2. Press the UP or DOWN buttons until **"DMX Value"** is displayed, and press ENTER.
3. A DMX Channel will be displayed. **Example:** Prism, Color Wheel, Gobo Wheel, etc... Press ENTER when you find the DMX channel that you would like to check. When you press ENTER the DMX value of that channel will displayed.
4. Press the MODE/ESC button to exit.

**Slave Mode** - This function lets you designate the unit as the slave in

a Master-Slave configuration.

1. Access the main menu, and press the UP or DOWN buttons so that “**Function**” is highlighted, then press ENTER.
2. Press the UP or DOWN buttons until “**Slave Mode**” is displayed, and press ENTER.
3. Either Slave 1, Slave 2, or Slave 3 will be displayed. Press ENTER to select either of the three, or press MODE/ESC button to exit.

**Auto Program** - This function allows the internal programs to run in either stand-alone or master/slave mode. In “Master” mode the fixture will send DMX data to other fixtures connect via the DMX chain. In “Alone” mode the fixture will operate as a single fixture. The program for this mode is selected in the “Select program” section of the control menu. You can set the number of steps under “Edit program”. You can edit the individual scenes under “Edit scenes”. With this function, you can run the individual scenes either automatically, i.e. with the adjusted Step-Time.

1. Access the main menu, and press the UP or DOWN buttons so that “**Function**” is highlighted, then press ENTER.
2. Press the UP or DOWN buttons until “**Auto Program**” is displayed, and press ENTER.
3. Either “Master” or “Alone” will be displayed.
4. Press ENTER to to make your selection, or press MODE/ESC button to exit.

**Sound Control** - With this function, the internal program will run in sound active mode.

1. Access the main menu, and press the UP or DOWN buttons so that “**Function**” is highlighted, then press ENTER.
2. Press the UP or DOWN buttons until “**Sound Control**” is displayed, press ENTER.
3. Either “Master” or “Alone” will be displayed. Use the UP or DOWN buttons to change the operating mode.
4. Press ENTER to to make your selection, or press MODE/ESC

button to exit.

### INFORMATION

**Time Information** (*Time information is always represented in hours*)

**Current Time** - This will allow you to check units current running time.

1. Press the MODE/ESC button to access the main menu. Press the UP or DOWN buttons so that “**Information**” is highlighted, then press ENTER.
2. Press the UP or DOWN buttons until “**Time Information**” is displayed, press ENTER.
3. Press UP or DOWN buttons, until “**Current Time**” is displayed, and press ENTER.
4. “**XXXX**” will now be displayed. “**XXXX**” represents the current running time.
5. Press ENTER or press MODE/ESC to exit.

**Total Running Time** - This will allow you to check units total running time.

1. Press the MODE/ESC button to access the main menu. Press the UP or DOWN buttons so that “**Information**” is highlighted, then press ENTER.
2. Press the UP or DOWN buttons until “**Time Information**” is displayed, press ENTER.
3. Press UP or DOWN buttons, until “**Total Run Time**” is displayed, and press ENTER.
4. “**XXXX**” will now be displayed. “**XXXX**” represents the total running time.
5. Press ENTER or press MODE/ESC to exit.

**Last Run Time** - This will allow you to check the last running time of the lamp.

1. Press the MODE/ESC button to access the main menu. Press

the UP or DOWN buttons so that “**Information**” is highlighted, then press ENTER.

2. Press the UP or DOWN buttons until “**Time Information**” is displayed, press ENTER.
3. Press UP or DOWN buttons, until “**Last Run Time**” is displayed, and press ENTER.
4. “**XXXX**” will now be displayed. “**XXXX**” represents the last running time.
5. Press ENTER or press MODE/ESC to exit.

**Lamp Hours** - This will allow you to check the running time of the lamp.

1. Press the MODE/ESC button to access the main menu. Press the UP or DOWN buttons so that “**Information**” is highlighted, then press ENTER.
2. Press the UP or DOWN buttons until “**Time Information**” is displayed, press ENTER.
3. Press UP or DOWN buttons, until “**Lamp Hours**” is displayed, and press ENTER.
4. “**XXXX**” will now be displayed. “**XXXX**” represents the lamp running time.
5. Press ENTER or press MODE/ESC to exit.

**Lamp Off Time** - This will allow you to check the running time of the lamp the last time that the lamp was On.

1. Press the MODE/ESC button to access the main menu. Press the UP or DOWN buttons so that “**Information**” is highlighted, then press ENTER.
2. Press the UP or DOWN buttons until “**Time Information**” is displayed, press ENTER.
3. Press UP or DOWN buttons, until “**Lamp Off Time**” is displayed, and press ENTER.
4. “**XXXX**” will now be displayed. “**XXXX**” represents the running

time of the lamp the last time that the lamp was On.

5. Press ENTER or press MODE/ESC to exit.

**Last Run Password** - This will display the timer password.

1. Press the MODE/ESC button to access the main menu. Press the UP or DOWN buttons so that “**Information**” is highlighted, then press ENTER.
2. Press the UP or DOWN buttons until “**Time Information**” is displayed, press ENTER.
3. Press UP or DOWN buttons, until “**Last Run Password**” is displayed, and press ENTER.
4. The “**Last Run Password**” is 038.
5. Press ENTER or press MODE/ESC to exit.

**Clean Last Run** - This will allow you to clear the last run time of the unit. You need to put in the **Last Run Password** before doing this. Please see the section before this.

1. Press the MODE/ESC button to access the main menu. Press the UP or DOWN buttons so that “**Information**” is highlighted, then press ENTER.
2. Press the UP or DOWN buttons until “**Time Information**” is displayed, press ENTER.
3. Press UP or DOWN buttons, until “**Clean Last Run**” is displayed, and press ENTER.
4. Either “**Off**” or “**On**” will be displayed, use the UP and DOWN buttons to toggle between.
5. Press ENTER to confirm your selection or press MODE/ESC to exit.

**Lamp Time Password** - This will display the lamp timer password.

1. Press the MODE/ESC button to access the main menu. Press the UP or DOWN buttons so that “**Information**” is highlighted, then press ENTER.
2. Press the UP or DOWN buttons until “**Time Information**” is displayed,

played, press ENTER.

3. Press UP or DOWN buttons, until **“Lamp Time Password”** is displayed, and press ENTER.
4. The **“Lamp Time Password”** is 038.
5. Press ENTER or press MODE/ESC to exit.

**Clean Lamp Time** - This will allow you to clear the lamp time running time. Please clear the lamp running time every time you replace the lamp. You need to put in the **Lamp Time Password** before doing this. Please see the section before this.

1. Press the MODE/ESC button to access the main menu. Press the UP or DOWN buttons so that **“Information”** is highlighted, then press ENTER.
2. Press the UP or DOWN buttons until **“Time Information”** is displayed, press ENTER.
3. Press UP or DOWN buttons, until **“Clear Lamp Time”** is displayed, and press ENTER.
4. Either **“Off”** or **“On”** will be displayed, use the UP and DOWN buttons to toggle between.
5. Press ENTER to confirm your selection or press MODE/ESC to exit.

**Temperature Info** - This will allow you to check the moving head temperature.

1. Press the MODE/ESC button to access the main menu. Press the UP or DOWN buttons so that **“Information”** is highlighted, then press ENTER.
2. Press the UP or DOWN buttons until **“Temperature Info”** is displayed, press ENTER.
3. **“Head Temperature”** will now be displayed, press ENTER.
4. **“XXX”** will now be displayed. **“XXX”** represents the current temperature of the moving head.
5. Press ENTER or press MODE/ESC to exit.

**Software Version** - This will allow you to see the software version you are currently running.

1. Press the MODE/ESC button to access the main menu. Press the UP or DOWN buttons so that **“Information”** is highlighted, then press ENTER.
2. Press the UP or DOWN buttons until **“Software Version”** is displayed, press ENTER.
3. **“VX.X”** will now be displayed. **“X.X”** represents the software version.
4. Press ENTER or press MODE/ESC to exit.

#### **LAMP CONTROL -**

**Lamp On/Off** - With this function you can switch the lamp on or off via the control board.

1. Press the MODE/ESC button to access the main menu. Press the UP or DOWN buttons so that **“Lamp Control”** is highlighted, then press ENTER.
2. Press the UP or DOWN buttons until **“Lamp Off/On”** is displayed, press ENTER.
3. Either **“Off”** or **“On”** will be displayed, use the UP and DOWN buttons to toggle between.
4. Press ENTER to confirm your selection or press MODE/ESC to exit.

**Automatic On** - With this function you can have the lamp automatically turn On when switching on the power.

1. Press the MODE/ESC button to access the main menu. Press the UP or DOWN buttons so that **“Lamp Control”** is highlighted, then press ENTER.
2. Press the UP or DOWN buttons until **“Automatic On”** is displayed, press ENTER.
3. Either **“Off”** or **“On”** will be displayed, use the UP and DOWN buttons to toggle between.
4. Press ENTER to confirm your selection or press MODE/ESC to

exit.

**Lamp on via external controller** - With this function you can select if you want to switch the lamp on via an external controller. This is used in conjunction with Internal Programs DMX channel, DMX values 40-59.

1. Press the MODE/ESC button to access the main menu. Press the UP or DOWN buttons so that **“Lamp Control”** is highlighted, then press ENTER.
2. Press the UP or DOWN buttons until **“Lamp On Via DMX”** is displayed, press ENTER.
3. Either **“Off”** or **“On”** will be displayed, use the UP and DOWN buttons to toggle between. Select **“On”** if you wish to activate this function, or **“Off”** to deactivate.
4. Press ENTER to confirm your selection or press MODE/ESC to exit.

**Lamp off via external controller** - With this function you can select if you want to switch the lamp off via an external controller. This is used in conjunction with Internal Programs DMX channel, DMX values 60-79.

1. Press the MODE/ESC button to access the main menu. Press the UP or DOWN buttons so that **“Lamp Control”** is highlighted, then press ENTER.
2. Press the UP or DOWN buttons until **“Lamp Off Via DMX”** is displayed, press ENTER.
3. Either **“Off”** or **“On”** will be displayed, use the UP and DOWN buttons to toggle between. Select **“On”** if you wish to activate this function, or **“Off”** to deactivate.
4. Press ENTER to confirm your selection or press MODE/ESC to exit.

**Max on at temp.** - With this function you can set the inside temperature from which the lamp will restrike after automatic shut off.

1. Press the MODE/ESC button to access the main menu. Press the

UP or DOWN buttons so that **“Lamp Control”** is highlighted, then press ENTER.

2. Press the UP or DOWN buttons until **“Max On at Temp”** is displayed, press ENTER.
3. **“113°F”** or **“45°C”** should now be displayed. **“113°F”** represents the temperature that the lamp will restrike at. The temperature that is recommended is **113°F**.
4. Press ENTER to confirm your selection or press MODE/ESC to exit.

**Lamp off temp.** - With this function you can set the inside temperature at which point the lamp will shut off.

1. Press the MODE/ESC button to access the main menu. Press the UP or DOWN buttons so that **“Lamp Control”** is highlighted, then press ENTER.
2. Press the UP or DOWN buttons until **“Max On at Temp”** is displayed, press ENTER.
3. **“266°F”** or **“130°C”** should now be displayed. **“266°F”** or **“130°C”** represents the temperature that the lamp will automatically switch off at. The temperature that is recommended is **266°F**.
4. Press ENTER to confirm your selection or press MODE/ESC to exit.

**NOTE: When the temperature around the lamp is higher than the preset value for longer than 5 mins, the unit will automatically shut Off the lamp. If the lamp is automatically shut off due to over heat, it can not be restriked automatically, it must be turned On again manually.**

## PERSONALITY

### Time Information

**Address via DMX** - With this function you can adjust the DMX address via external controller.

1. Press the MODE/ESC button to access the main menu. Press the UP or DOWN buttons so that **“Personality”** is highlighted, then press



ENTER.

2. Press the UP or DOWN buttons until **“Status Setting”** is displayed, press ENTER.
3. Press UP or DOWN buttons, until **“Address via DMX”** is displayed, and press ENTER.
4. Either **“Off”** or **“On”** will be displayed, use the UP and DOWN buttons to toggle between.
5. Press ENTER to confirm your selection or press MODE/ESC to exit.

**To use this function follow these instructions:**

To adjust the address of your unit you must first go to the address that it is currently set to. From there you can adjust the address. First make sure all channels are set to the value of “0”.

1. On your DMX controller set the DMX value of Channel 1 to the value “7”.
2. Now set the DMX value of Channel 2 to the value “7” to adjust the starting address between 1 and 255. To adjust the address between 256 and 511 set Channel 2 to the value “8” .
3. Set the DMX value of Channel 3 to your desired starting address. This will take about 20 seconds before the unit accepts the new DMX address.

**EXAMPLE:** If you want the address to be 57, you must first set the address that is currently assigned to the unit. Then set Channel 1’s value to “7”, Channel 2’s value to “7”, and Channel 3’s value to “57”. Wait 20 seconds and the address should change on the unit to “57”.

**2ND EXAMPLE:** If you want the address to be 420, you must first set the address that is currently assigned to the unit. If you want the set the address to 420, set Channel 1’s value to “7”, Channel 2’s value to “8”, and Channel 3’s to “164”. (256 + 164 = 420).

**No DMX status** - With this function if the DMX signal is suddenly lost, the unit will automatically go into 1 of 3 modes.

1. Press the MODE/ESC button to access the main menu. Press the UP or DOWN buttons so that **“Personality”** is highlighted, then press ENTER.
2. Press the UP or DOWN buttons until **“Status Setting”** is displayed, press ENTER.
3. Press UP or DOWN buttons, until **“No DMX Status”** is displayed, and press ENTER.
4. Either **“Hold”** (Last DMX setting), **“Close”** (Blackout), **“Music”** (Sound Active), or **“Auto”** (Auto Program) will be displayed, use the UP and DOWN buttons to toggle between.
5. Press ENTER to confirm your selection or press MODE/ESC to exit.

**No DMX status** - With this function if the DMX signal is suddenly lost, the unit will automatically go into 1 of 3 modes.

1. Press the MODE/ESC button to access the main menu. Press the UP or DOWN buttons so that **“Personality”** is highlighted, then press ENTER.
2. Press the UP or DOWN buttons until **“Status Setting”** is displayed, press ENTER.
3. Press UP or DOWN buttons, until **“No DMX Status”** is displayed, and press ENTER.
4. Either **“Hold”** (Last DMX setting), **“Close”** (Blackout), **“Music”** (Sound Active), or **“Auto”** (Auto Program) will be displayed, use the UP and DOWN buttons to toggle between.
5. Press ENTER to confirm your selection or press MODE/ESC to exit.

**Pan Reverse** - With this function you can reverse the Pan movement.

1. Press the MODE/ESC button to access the main menu. Press the UP or DOWN buttons so that **“Personality”** is highlighted, then press ENTER.
2. Press the UP or DOWN buttons until **“Status Setting”** is displayed, press ENTER.

3. Press UP or DOWN buttons, until **“Pan Reverse”** is displayed, and press ENTER.
4. Either **“Off”** or **“On”** will be displayed, use the UP and DOWN buttons to toggle between.
5. Press ENTER to confirm your selection or press MODE/ESC to exit.

**Tilt Reverse** - With this function you can reverse the Tilt movement.

1. Press the MODE/ESC button to access the main menu. Press the UP or DOWN buttons so that **“Personality”** is highlighted, then press ENTER.
2. Press the UP or DOWN buttons until **“Status Setting”** is displayed, press ENTER.
3. Press UP or DOWN buttons, until **“Tilt Reverse”** is displayed, and press ENTER.
4. Either **“Off”** or **“On”** will be displayed, use the UP and DOWN buttons to toggle between.
5. Press ENTER to confirm your selection or press MODE/ESC to exit.

**Mic Sensitivity** - With this function you can set the microphone sensitivity. The default setting is 70%. You can adjust the sensitivity between 0%-99%

1. Press the MODE/ESC button to access the main menu. Press the UP or DOWN buttons so that **“Personality”** is highlighted, then press ENTER.
2. Press the UP or DOWN buttons until **“Status Setting”** is displayed, press ENTER.
3. Press UP or DOWN buttons, until **“Mic Sensitivity”** is displayed, and press ENTER.
4. **“70%”** will be displayed, use the UP and DOWN buttons to adjust the sensitivity between 0%-99%.
5. Press ENTER to confirm your selection or press MODE/ESC to exit.

**Hibernation** - With this function the lamp and step motors will power off if there is no DMX signal within 15 mins (factory default). Once it receives a DMX signal, the fixture will reset itself.

1. Press the MODE/ESC button to access the main menu. Press the UP or DOWN buttons so that **“Personality”** is highlighted, then press ENTER.
2. Press the UP or DOWN buttons until **“Status Setting”** is displayed, press ENTER.
3. Press UP or DOWN buttons, until **“Hibernation”** is displayed, and press ENTER.
4. **“15M”** will be displayed, use the UP and DOWN buttons to adjust the hibernation period between 01M-99M or “Off”.
5. Press ENTER to confirm your selection or press MODE/ESC to exit.

### **Service Setting**

**Password** - With this function you can enter the RDM password so that you can access and change the RDM ID number.

1. Press the MODE/ESC button to access the main menu. Press the UP or DOWN buttons so that **“Personality”** is highlighted, then press ENTER.
2. Press the UP or DOWN buttons until **“Service Settings”** is displayed, press ENTER.
3. Press UP or DOWN buttons, until **“Password”** is displayed, and press ENTER.
4. The **“Password”** is 050.
5. Press ENTER or press MODE/ESC to exit.

**RDM PID** - RDM stands for “Remote Device Management”. This feature lets you control every aspect of your fixture remotely from an RDM controller. Manual settings like adjusting the DMX address are no longer needed. This is especially useful when the unit is installed in a remote area.

In this submenu you can see the units RDM ID number and adjust it

as well.

1. Press the MODE/ESC button to access the main menu. Press the UP or DOWN buttons so that **“Personality”** is highlighted, then press ENTER.
2. Press the UP or DOWN buttons until **“Service Settings”** is displayed, press ENTER.
3. Press UP or DOWN buttons, until **“RDM PID”** is displayed, and press ENTER.
4. “XXXXXX” will be displayed. “XXXXXX” represents the units current RDM ID.
5. Press ENTER or press MODE/ESC to exit.

### **Fans Control**

**Auto Fan Speed** - With this function you can adjust the speed of the running fans.

1. Press the MODE/ESC button to access the main menu. Press the UP or DOWN buttons so that **“Personality”** is highlighted, then press ENTER.
2. Press the UP or DOWN buttons until **“Fans Control”** is displayed, press ENTER.
3. Either **“Auto Fan Speed”** (default), **“Low Fan Speed”**, or **“High Fan Speed”** will be displayed, use the UP and DOWN buttons to toggle between.
4. Press ENTER to confirm your selection or press MODE/ESC to exit.

### **Display Setting**

**Shutoff Time** - With this function you can have the LCD display after 2-59 minutes. Use this function to adjust the time.

1. Press the MODE/ESC button to access the main menu. Press the UP or DOWN buttons so that **“Personality”** is highlighted, then press ENTER.
2. Press the UP or DOWN buttons until **“Display Setting”** is displayed, press ENTER.

played, press ENTER.

3. Press UP or DOWN buttons, until **“Shutoff Time”** is displayed, and press ENTER.
4. **“05m”** (5 minutes) will be displayed, use the UP and DOWN buttons to adjust the shutoff time between 02m-60m or **“Off”**.
5. Press ENTER to confirm your selection or press MODE/ESC to exit.

**Display Reverse** - With this function you can rotate (flip) the display 180 degrees.

1. Press the MODE/ESC button to access the main menu. Press the UP or DOWN buttons so that **“Personality”** is highlighted, then press ENTER.
2. Press the UP or DOWN buttons until **“Display Setting”** is displayed, press ENTER.
3. Press UP or DOWN buttons, until **“Display Reverse”** is displayed, and press ENTER.
4. Either **“Off”** or **“On”** will be displayed, use the UP and DOWN buttons to toggle between.
5. Press ENTER to confirm your selection or press MODE/ESC to exit.

**Key Lock** - With this function activated the buttons will lock automatically after 15 seconds.

1. Press the MODE/ESC button to access the main menu. Press the UP or DOWN buttons so that **“Personality”** is highlighted, then press ENTER.
2. Press the UP or DOWN buttons until **“Display Setting”** is displayed, press ENTER.
3. Press UP or DOWN buttons, until **“Key Lock”** is displayed, and press ENTER.
4. Either **“Off”** or **“On”** will be displayed, use the UP and DOWN buttons to toggle between.

5. Press ENTER to confirm your selection or press MODE/ESC to exit.

**Temperature C/F** - With this function, you can change the temperature display to show either Celsius or Fahrenheit.

1. Press the MODE/ESC button to access the main menu. Press the UP or DOWN buttons so that **“Personality”** is highlighted, then press ENTER.
2. Press UP or DOWN buttons, until **“Temperature C/F”** is displayed, and press ENTER.
3. Either **“Celsius”** or **“Fahrenheit”** will be displayed, use the UP and DOWN buttons to toggle between.
4. Press ENTER to confirm your selection or press MODE/ESC to exit.

**Initial Status**- In this menu you are able to check initial effect position.

1. Press the MODE/ESC button to access the main menu. Press the UP or DOWN buttons so that **“Personality”** is highlighted, then press ENTER.
2. Press the UP or DOWN buttons until **“Initial Status”** is displayed, press ENTER.
3. **“PAN =XXX”** will be displayed. **“XXX”** represents the current effect position.
4. Press ENTER or press MODE/ESC to exit.

#### **Reset Default** -

1. Press the MODE/ESC button to access the main menu. Press the UP or DOWN buttons so that **“Personality”** is highlighted, then press ENTER.
2. Press the UP or DOWN buttons until **“Reset Default”** is displayed, press ENTER.
3. Either **“Off”** or **“On”** will be displayed, use the UP and DOWN buttons to toggle between.

4. Press ENTER to confirm your selection or press MODE/ESC to exit.

#### **RESET FUNCTION**

**Reset All** - With this function you can all the motors.

1. Press the MODE/ESC button to access the main menu. Press the UP or DOWN buttons so that **“Reset Function”** is highlighted, then press ENTER.
2. Press the UP or DOWN buttons until **“Reset All”** is displayed, press ENTER.
3. Press ENTER to confirm your selection or press MODE/ESC to exit.

**Reset Pan & Tilt** - With this function you can reset the Pan & Tilt motors.

1. Press the MODE/ESC button to access the main menu. Press the UP or DOWN buttons so that **“Reset Function”** is highlighted, then press ENTER.
2. Press the UP or DOWN buttons until **“Reset Pan/Tilt”** is displayed, press ENTER.
3. Press ENTER to confirm your selection or press MODE/ESC to exit.

**Reset Colors** - With this function you can reset the color wheel.

1. Press the MODE/ESC button to access the main menu. Press the UP or DOWN buttons so that **“Reset Function”** is highlighted, then press ENTER.
2. Press the UP or DOWN buttons until **“Reset Colors”** is displayed, press ENTER.
3. Press ENTER to confirm your selection or press MODE/ESC to exit.

**Reset Gobos** - With this function you can reset the gobo wheel.

1. Press the MODE/ESC button to access the main menu. Press the UP or DOWN buttons so that **“Reset Function”** is highlighted, then

press ENTER.

2. Press the UP or DOWN buttons until **“Reset Gobos”** is displayed, press ENTER.

3. Press ENTER to confirm your selection or press MODE/ESC to exit.

**Reset Shutter** - With this function you can reset the shutter motor.

1. Press the MODE/ESC button to access the main menu. Press the UP or DOWN buttons so that **“Reset Function”** is highlighted, then press ENTER.

2. Press the UP or DOWN buttons until **“Reset Shutter”** is displayed, press ENTER.

3. Press ENTER to confirm your selection or press MODE/ESC to exit.

**Reset Others** - With this function you can reset all other motors.

1. Press the MODE/ESC button to access the main menu. Press the UP or DOWN buttons so that **“Reset Function”** is highlighted, then press ENTER.

2. Press the UP or DOWN buttons until **“Reset Others”** is displayed, press ENTER.

3. Press ENTER to confirm your selection or press MODE/ESC to exit.

## EFFECT ADJUST

**Test Channel** - With this function you can test/correct each channel function.

1. Press the MODE/ESC button to access the main menu. Press the UP or DOWN buttons so that **“Effect Adjust”** is highlighted, then press ENTER.

2. Press the UP or DOWN buttons until **“Test Channel”** is displayed, press ENTER.

3. Use the UP or DOWN buttons to scroll through the various channels.

4. Press ENTER or press MODE/ESC to exit.

**Manual Control** - With this function you can easily adjust the lamp. All effects will be canceled, the shutter will open and output intensity will be 100%. With the individual functions you can focus the light on flat surface (a wall) and finely adjust the lamp.

1. Press the MODE/ESC button to access the main menu. Press the UP or DOWN buttons so that **“Effect Adjust”** is highlighted, then press ENTER.

2. Press the UP or DOWN buttons until **“Manual Control”** is displayed, press ENTER.

3. Use the UP or DOWN buttons to scroll through the various functions. Press ENTER when you find the function you would like to adjust.

4. Press ENTER or press MODE/ESC to exit.

**Calibration** - With this function you can calibrate and adjust the effects wheels to their correct positions. The Calibration password 050.

1. Press the MODE/ESC button to access the main menu. Press the UP or DOWN buttons so that **“Effect Adjust”** is highlighted, then press ENTER.

2. Press the UP or DOWN buttons until **“Calibration”** is displayed, press ENTER.

3. “XXXX” will be displayed. The password is 050.

4. Press ENTER to confirm or press MODE/ESC to exit.

## USER MODE SET

**User Mode** -

1. Press the MODE/ESC button to access the main menu. Press the UP or DOWN buttons so that **“User Mode Set”** is highlighted, then press ENTER.

2. Press the UP or DOWN buttons until **“User Mode”** is displayed, press ENTER.



3. Use the UP or DOWN buttons to scroll through the 3 DMX Channel Modes.

**Standard Mode** - This is 13 Channel Mode.

**Basic Mode** - This is 11 Channel Mode.

**Extended Mode** - This is 18 Channel Mode.

4. Press the MODE/ESC button once to return to the “**User Mode Set**” menu. Use the UP or DOWN buttons to scroll through the Edit modes. Press ENTER to select any of the Edit modes.

**Edit User Mode** – This function allows the user to make the actual changes in the user defined modes that are created in the previous function.

**EDIT PROGRAM:** - The fixture comes equipped with a built-in DMX recorder that allows custom programs to be installed and recalled directly from the fixture’s control board. Programs can be created and stored using the fixture’s control board or by using an external DMX controller.

**Select Program** – This function allows the user to select one of ten of the user defined built-in programs. This program is then accessed in “Function Mode” under “Program Run.”

**Edit Program** – This function allows the user to edit the internal built-in programs.

**Edit Scenes** – This function allows the user to edit or define the actual scenes that are stored in the user defined built-in programs that are accessed in the previous step.

**Rec Controller** - The Vizi Roller Beam 2R features an integrated DMX recorder. Preprogrammed scenes can be transmitted to the fixture via any DMX compliant controller. This function allows those scenes to be stored in to the fixture’s built-in memory and then subsequently used to create the user-defined programs.

When power is applied, the unit will automatically enter a “reset/test” mode. This mode brings all the internal motors to a home position. If there is an internal problem with one or more of the motors an error code will flash in the display in the form of “XXer”, “XX” will represent a function number. For example, when the display shows “03Er,” it means there is some type of error with the channel 3 motor. If there are multiple errors during the start-up process they will all flash in the display. For example: if the fixtures has errors on channel 1 and channel 3 all at the same time, you will see the error message flash “01Er”, and “03Er repeated 5 times.

If an error does occur during the initial start-up procedure the fixture will self-generate a second reset signal and try to realign all the motors and correct the errors, if the errors persist after a second attempt a third attempt will be made.

If after a third attempt all the errors have not been corrected the fixture will make the following determinations:

- 1) 3 or more errors - The fixture cannot function properly with three or more errors therefore the fixture will place itself in a stand-by mode until subsequent repairs can be made.
- 2) Less than 3 errors - If the fixture has less than 3 errors, therefore most other functions will work properly. The fixture will attempt to operate normally until the errors can be corrected by a technician. The errors in question will remain flashing in the display as a reminder of internal errors.

03Er – TILT movement error:

This message will appear after a fixture reset, if the tilt magnetic-indexing circuit malfunctions (sensor failed or magnet is missing) or there is a stepper motor failure (defective motor or a defective motor IC drive on the main PCB).

05Er – COLOR WHEEL error:

This message will appear after a fixture reset, if the head’s magnetic-indexing circuit malfunctions (sensor failed or magnet is

missing) or there is a stepper motor failure (defective motor or a defective motor IC drive on the main PCB).

06Er – FIXED GOBOS error:

This message will appear after a fixture reset, if the magnetic-indexing circuit malfunctions (sensor failed or magnet is missing) or there is a stepper motor failure (defective motor or a defective motor IC drive on the main PCB).

**Universal DMX Control:** This function allows you to use a universal DMX-512 controller such as the Elation® DMX Operator™ or Elation® Show Designer™ to control head movement, the color wheel, gobo wheel, prism, master dimmer, shutter (strobe), and various other features. A DMX controller allows you to create unique programs tailored to your individual needs.

1. The Vizi Roller Beam 2R has a 11 Channel mode, 13 Channel mode, and 18 Channel mode. See pages 41-52 for detailed description of the DMX traits.
2. To control your fixture in DMX mode, follow the set-up procedures on pages 13-15 as well as the set-up specifications that are included with your DMX controller.
3. Use the controller's faders to control the various DMX fixture traits.
4. This will allow you to create your own programs.
5. Follow the directions on page 35 to select your DMX Channel mode, and follow the instruction on page 17 to set the DMX address.
6. For longer cable runs (more than a 100 feet) use a terminator on the last fixture.
7. For help operating in DMX mode consult the manual included with your DMX controller.

**Stand-Alone (Sound Active or Auto Program):** This mode allows a single unit to run to the beat of the music or run through a built-in program.

**AUTO PROGRAM:**

1. Access the main menu, and press the UP or DOWN buttons so that "**Function**" is highlighted, then press ENTER.
2. Press the UP or DOWN buttons until "**Auto Program**" is displayed, and press ENTER.
3. Either "Master" or "Alone" will be displayed. Using the UP or DOWN buttons select "Alone" and press ENTER.

**SOUND ACTIVE:**

1. Access the main menu, and press the UP or DOWN buttons so that "**Function**" is highlighted, then press ENTER.
2. Press the UP or DOWN buttons until "**Sound Control**" is displayed, press ENTER.
3. Either "Master" or "Alone" will be displayed. Using the UP or

**Vizi Roller Beam 2R****Operation**

DOWN buttons select “Alone” and press ENTER.

**Master-Slave Operation (Sound Active or Auto Program):**

This function will allow you to link up to 16 units together and operate without a controller. The units can run a built-in program or run in sound active mode. In Master-Slave operation one unit will act as the controlling unit and the others will react to the controlling units programs. Any unit can act as a Master or as a Slave.

1. Using standard XLR microphone cables, daisy chain your units together via the XLR connector on the rear of the units. Remember the Male XLR connector is the input and the Female XLR connector is the output. The first unit in the chain (master) will use the female XLR connector only - The last unit in the chain will use the male XLR connector only. For longer cable runs we suggest a terminator at the last fixture.
2. On your “Master” unit, access the main menu, and press the UP or DOWN buttons so that “**Function**” is highlighted, then press ENTER.
3. Select your desired operating mode. Use the UP or DOWN buttons to select between “**Auto Program**” or “**Sound Control**”, press ENTER to select your desired program.
4. Either “**Master**” or “**Alone**” will be displayed. Using the UP or DOWN buttons select “**Master**” and press ENTER.
5. For your “Slave” units, access the main menu, and press the UP or DOWN buttons so that “**Function**” is highlighted, then press ENTER.
6. Press the UP or DOWN buttons until “**Slave Mode**” is displayed, and press ENTER.
7. Either Slave 1, Slave 2, or Slave 3 will be displayed. Select your desired Slave setting and press ENTER.
5. Press MODE/ESC if you want to return to the main menu.
6. You may change the show or invert the pan and tilt functions in the system menu by following the directions on pages 26-27.

**Vizi Roller Beam 2R****11 Channel DMX Mode**

Channel	Value	Function
1	0 - 255	PAN MOVEMENT 8bit
2	0 - 255	TILT MOVEMENT 8bit
3	0 - 8 9 - 17 18 - 26 27 - 35 36 - 44 45 - 53 54 - 62 63 - 71 72 - 80 81 - 89 90 - 98 99 - 107 108 - 116 117 - 127 128 - 189  190 - 193 194 - 255	OPEN COLOR 1 COLOR 2 COLOR 3 COLOR 4 COLOR 5 COLOR 6 COLOR 7 COLOR 8 COLOR 9 COLOR 10 COLOR 11 COLOR 12 COLOR 13 FORWARD RAINBOW EFFECT FAST - SLOW NO ROTATION BACKWARDS RAINBOW EFFECT SLOW - FAST
4	0 - 7 8 - 15 16 - 23 24 - 31 32 - 39 40 - 47 48 - 55 56 - 63 64 - 71 72 - 79 80 - 87 88 - 95	GOBOS OPEN GOBO 1 GOBO 2 GOBO 3 GOBO 4 GOBO 5 GOBO 6 GOBO 7 GOBO 8 GOBO 9 GOBO 10 GOBO 11

Vizi Roller Beam 2R		11 Channel DMX Mode
Channel	Value	Function
4		GOBOS CONT.
	96 - 103	GOBO 12
	104 - 111	GOBO 13
	112 - 119	GOBO 14
	120 - 126	GOBO 1 SHAKE
	127 - 133	GOBO 2 SHAKE
	134 - 140	GOBO 3 SHAKE
	141 - 147	GOBO 4 SHAKE
	148 - 154	GOBO 5 SHAKE
	155 - 161	GOBO 6 SHAKE
	162 - 168	GOBO 7 SHAKE
	169 - 175	GOBO 8 SHAKE
	176 - 182	GOBO 9 SHAKE
	183 - 189	GOBO 10 SHAKE
	190 - 196	GOBO 11 SHAKE
	197 - 203	GOBO 12 SHAKE
	204 - 210	GOBO 13 SHAKE
	211 - 217	GOBO 14 SHAKE
	218 - 255	GOBO WHEEL ROTATION SLOW - FAST
	5	0 - 127
128 - 189		BARREL INDEXING FORWARDS BARREL ROTATION FAST - SLOW
190 - 193		NO ROTATION
194 - 255		BACKWARDS BARREL ROTATION SLOW - FAST
6	0 - 31	PRISM/GOBO MACROS OPEN
	32 - 127	5 FACET PRISM
	128 - 135	MACRO 1
	136 - 143	MACRO 2
	144 - 151	MACRO 3
	152 - 159	MACRO 4

Vizi Roller Beam 2R		11 Channel DMX Mode
Channel	Value	Function
6		PRISM/GOBO MACROS
	160 - 167	MACRO 5
	168 - 175	MACRO 6
	176 - 183	MACRO 7
	184 - 191	MACRO 8
	192 - 199	MACRO 9
	200 - 207	MACRO 10
	208 - 215	MACRO 11
	216 - 223	MACRO 12
	224 - 231	MACRO 13
	232 - 239	MACRO 14
	240 - 247	MACRO 15
	248 - 255	MACRO 16
	7	0 - 127
128 - 189		PRISM INDEXING FORWARD PRISM ROTATION FAST - SLOW
190 - 193		NO ROTATION
194 - 255		BACKWARD PRISM ROTATION SLOW - FAST
8	0 - 31	SHUTTER & STROBE
	32 - 63	SHUTTER CLOSED
	64 - 95	SHUTTER OPEN
	96 - 127	STROBING SLOW - FAST
	128 - 159	SHUTTER OPEN
	160 - 191	PULSE EFFECT IN SEQUENCES
	192 - 223	SHUTTER OPEN
	224 - 255	RANDOM STROBE SLOW - FAST SHUTTER OPEN
9	0 - 255	DIMMER INTENSITY 0% - 100%
10	0 - 225 226 - 235	PAN/TILT MOVEMENT SPEED MAX TO MIN. SPEED BLACKOUT BY MOVEMENT

Vizi Roller Beam 2R		11 Channel DMX Mode
Channel	Value	Function
10		PAN/TILT MOVEMENT SPEED
	236 - 245	BLACKOUT BY WHEEL CHANGING
	246 - 255	NO FUNCTION
11	0 - 19	LAMP ON/OFF, RESET & PROGRAMS
	20 - 29	COLOR CHANGE NORMAL
		COLOR CHANGE TO ANY POSITION
	30 - 39	LAMP ON/OFF, RESET & PROGRAMS
		COLOR & GOBO CHANGE TO ANY POSITION
	40 - 59	LAMP ON
	60 - 79	LAMP OFF
	80 - 84	ALL MOTOR RESET
	85 - 87	SCAN MOTOR RESET
	88 - 90	COLOR MOTOR RESET
	91 - 93	GOBO MOTOR RESET
	94 - 96	SHUTTER/DIMMER MOTOR RESET
	97 - 99	OTHER MOTOR RESET
	100 - 119	INTERNAL PROGRAM 1
	120 - 139	INTERNAL PROGRAM 2
	140 - 159	INTERNAL PROGRAM 3
	160 - 179	INTERNAL PROGRAM 4
180 - 199	INTERNAL PROGRAM 5	
200 - 219	INTERNAL PROGRAM 6	
220 - 239	INTERNAL PROGRAM 7	
240 - 255	SOUND ACTIVE PROGRAM	

Vizi Roller Beam 2R		13 Channel DMX Mode
Channel	Value	Function
1	0 - 255	PAN MOVEMENT 8bit
2	0 - 255	PAN FINE 16bit
3	0 - 255	TILT MOVEMENT 8bit
4	0 - 255	TILT FINE 16bit
5		COLOR WHEEL
	0 - 8	OPEN
	9 - 17	COLOR 1
	18 - 26	COLOR 2
	27 - 35	COLOR 3
	36 - 44	COLOR 4
	45 - 53	COLOR 5
	54 - 62	COLOR 6
	63 - 71	COLOR 7
	72 - 80	COLOR 8
	81 - 89	COLOR 9
	90 - 98	COLOR 10
	99 - 107	COLOR 11
	108 - 116	COLOR 12
117 - 127	COLOR 13	
128 - 189	FORWARD RAINBOW EFFECT	
	FAST - SLOW	
	NO ROTATION	
190 - 193	BACKWARDS RAINBOW EFFECT	
194 - 255	SLOW - FAST	
6		GOBOS
	0 - 7	OPEN
	8 - 15	GOBO 1
	16 - 23	GOBO 2
	24 - 31	GOBO 3
	32 - 39	GOBO 4
	40 - 47	GOBO 5
	48 - 55	GOBO 6
56 - 63	GOBO 7	



Vizi Roller Beam 2R		13 Channel DMX Mode
Channel	Value	Function
6		GOBOS CONT.
	64 - 71	GOBO 8
	72 - 79	GOBO 9
	80 - 87	GOBO 10
	88 - 95	GOBO 11
	96 - 103	GOBO 12
	104 - 111	GOBO 13
	112 - 119	GOBO 14
	120 - 126	GOBO 1 SHAKE
	127 - 133	GOBO 2 SHAKE
	134 - 140	GOBO 3 SHAKE
	141 - 147	GOBO 4 SHAKE
	148 - 154	GOBO 5 SHAKE
	155 - 161	GOBO 6 SHAKE
	162 - 168	GOBO 7 SHAKE
	169 - 175	GOBO 8 SHAKE
	176 - 182	GOBO 9 SHAKE
	183 - 189	GOBO 10 SHAKE
	190 - 196	GOBO 11 SHAKE
	197 - 203	GOBO 12 SHAKE
204 - 210	GOBO 13 SHAKE	
211 - 217	GOBO 14 SHAKE	
218 - 255	GOBO WHEEL ROTATION SLOW - FAST	
7	0 - 127	ROTATING BARREL
	128 - 189	BARREL INDEXING
	190 - 193	FORWARDS BARREL ROTATION FAST - SLOW
	194 - 255	NO ROTATION BACKWARDS BARREL ROTATION SLOW - FAST
8	0 - 31	PRISM/GOBO MACROS OPEN
	32 - 127	5 FACET PRISM

Vizi Roller Beam 2R		13 Channel DMX Mode
Channel	Value	Function
8		PRISM/GOBO MACROS
	128 - 135	MACRO 1
	136 - 143	MACRO 2
	144 - 151	MACRO 3
	152 - 159	MACRO 4
	160 - 167	MACRO 5
	168 - 175	MACRO 6
	176 - 183	MACRO 7
	184 - 191	MACRO 8
	192 - 199	MACRO 9
	200 - 207	MACRO 10
	208 - 215	MACRO 11
	216 - 223	MACRO 12
	224 - 231	MACRO 13
	232 - 239	MACRO 14
	240 - 247	MACRO 15
248 - 255	MACRO 16	
9	0 - 127	PRISM ROTATION
	128 - 189	PRISM INDEXING FORWARD PRISM ROTATION FAST - SLOW
	190 - 193	NO ROTATION
	194 - 255	BACKWARD PRISM ROTATION SLOW - FAST
10	0 - 31	SHUTTER & STROBE
	32 - 63	SHUTTER CLOSED
	64 - 95	SHUTTER OPEN
	96 - 127	STROBING SLOW - FAST
	128 - 159	SHUTTER OPEN
	160 - 191	PULSE EFFECT IN SEQUENCES
	192 - 223	SHUTTER OPEN
	224 - 255	RANDOM STROBE SLOW - FAST SHUTTER OPEN

Vizi Roller Beam 2R		13 Channel DMX Mode
Channel	Value	Function
11	0 - 255	DIMMER INTENSITY 0% - 100%
12	0 - 225 226 - 235 236 - 245 246 - 255	PAN/TILT MOVEMENT SPEED MAX TO MIN. SPEED BLACKOUT BY MOVEMENT BLACKOUT BY WHEEL CHANGING NO FUNCTION
13	0 - 19 20 - 29 30 - 39 40 - 59 60 - 79 80 - 84 85 - 87 88 - 90 91 - 93 94 - 96 97 - 99 100 - 119 120 - 139 140 - 159 160 - 179 180 - 199 200 - 219 220 - 239 240 - 255	LAMP ON/OFF, RESET & PROGRAMS COLOR CHANGE NORMAL COLOR CHANGE TO ANY POSITION COLOR & GOBO CHANGE TO ANY POSITION LAMP ON LAMP OFF ALL MOTOR RESET SCAN MOTOR RESET COLOR MOTOR RESET GOBO MOTOR RESET SHUTTER/DIMMER MOTOR RESET OTHER MOTOR RESET INTERNAL PROGRAM 1 INTERNAL PROGRAM 2 INTERNAL PROGRAM 3 INTERNAL PROGRAM 4 INTERNAL PROGRAM 5 INTERNAL PROGRAM 6 INTERNAL PROGRAM 7 SOUND ACTIVE PROGRAM

Vizi Roller Beam 2R		18 Channel DMX Mode
Channel	Value	Function
1	0 - 255	PAN MOVEMENT 8bit
2	0 - 255	PAN FINE 16bit
3	0 - 255	TILT MOVEMENT 8bit
4	0 - 255	TILT FINE 16bit
5	0 - 8 9 - 17 18 - 26 27 - 35 36 - 44 45 - 53 54 - 62 63 - 71 72 - 80 81 - 89 90 - 98 99 - 107 108 - 116 117 - 127 128 - 189 190 - 193 194 - 255	COLOR WHEEL OPEN COLOR 1 COLOR 2 COLOR 3 COLOR 4 COLOR 5 COLOR 6 COLOR 7 COLOR 8 COLOR 9 COLOR 10 COLOR 11 COLOR 12 COLOR 13 FORWARD RAINBOW EFFECT FAST - SLOW NO ROTATION BACKWARDS RAINBOW EFFECT SLOW - FAST
6	0 - 255	COLOR WHEEL FINE COLOR WHEEL CHANGE FINE
7	0 - 7 8 - 15 16 - 23 24 - 31 32 - 39 40 - 47	GOBOS OPEN GOBO 1 GOBO 2 GOBO 3 GOBO 4 GOBO 5

Vizi Roller Beam 2R		18 Channel DMX Mode
Channel	Value	Function
7		GOBOS
	48 - 55	GOBO 6
	56 - 63	GOBO 7
	64 - 71	GOBO 8
	72 - 79	GOBO 9
	80 - 87	GOBO 10
	88 - 95	GOBO 11
	96 - 103	GOBO 12
	104 - 111	GOBO 13
	112 - 119	GOBO 14
	120 - 126	GOBO 1 SHAKE
	127 - 133	GOBO 2 SHAKE
	134 - 140	GOBO 3 SHAKE
	141 - 147	GOBO 4 SHAKE
	148 - 154	GOBO 5 SHAKE
	155 - 161	GOBO 6 SHAKE
	162 - 168	GOBO 7 SHAKE
	169 - 175	GOBO 8 SHAKE
	176 - 182	GOBO 9 SHAKE
	183 - 189	GOBO 10 SHAKE
190 - 196	GOBO 11 SHAKE	
197 - 203	GOBO 12 SHAKE	
204 - 210	GOBO 13 SHAKE	
211 - 217	GOBO 14 SHAKE	
218 - 255	GOBO WHEEL ROTATION SLOW - FAST	
8	0 - 255	FIXED GOBO FINE INDEXING
9	0 - 127	ROTATING BARREL BARREL INDEXING
	128 - 189	FORWARDS BARREL ROTATION FAST - SLOW
	190 - 193	NO ROTATION
	194 - 255	BACKWARDS BARREL ROTATION SLOW - FAST

Vizi Roller Beam 2R		18 Channel DMX Mode
Channel	Value	Function
10	0 - 255	ROTATING BARREL INDEXING FINE INDEXING
11	0 - 31	PRISM/GOBO MACROS OPEN
	32 - 127	5 FACET PRISM
	128 - 135	MACRO 1
	136 - 143	MACRO 2
	144 - 151	MACRO 3
	152 - 159	MACRO 4
	160 - 167	MACRO 5
	168 - 175	MACRO 6
	176 - 183	MACRO 7
	184 - 191	MACRO 8
	192 - 199	MACRO 9
	200 - 207	MACRO 10
	208 - 215	MACRO 11
	216 - 223	MACRO 12
	224 - 231	MACRO 13
	232 - 239	MACRO 14
240 - 247	MACRO 15	
248 - 255	MACRO 16	
12	0 - 127	PRISM ROTATION PRISM INDEXING
	128 - 189	FORWARD PRISM ROTATION FAST - SLOW
	190 - 193	NO ROTATION
	194 - 255	BACKWARD PRISM ROTATION SLOW - FAST
13	0 - 255	PRISM ROTATION INDEXING
14	0 - 31	SHUTTER & STROBE SHUTTER CLOSED
	32 - 63	SHUTTER OPEN
	64 - 95	STROBING SLOW - FAST
	96 - 127	SHUTTER OPEN

Vizi Roller Beam 2R		18 Channel DMX Mode
Channel	Value	Function
14	128 - 159	SHUTTER & STROBE PULSE EFFECT IN SEQUENCES
	160 - 191	SHUTTER OPEN
	192 - 223	RANDOM STROBE SLOW - FAST
	224 - 255	SHUTTER OPEN
15	0 - 255	MASTER DIMMER 0% - 100%
16	0 - 255	FINE DIMMER INTENSITY
17	0 - 225	PAN/TILT MOVEMENT SPEED MAX TO MIN. SPEED
	226 - 235	BLACKOUT BY MOVEMENT
	236 - 245	BLACKOUT BY WHEEL CHANGING
	246 - 255	NO FUNCTION
18	0 - 19	LAMP ON/OFF, RESET & PROGRAMS COLOR CHANGE NORMAL
	20 - 29	COLOR CHANGE TO ANY POSITION
	30 - 39	COLOR & GOBO CHANGE TO ANY POSITION
	40 - 59	LAMP ON
	60 - 79	LAMP OFF
	80 - 84	ALL MOTOR RESET
	85 - 87	SCAN MOTOR RESET
	88 - 90	COLOR MOTOR RESET
	91 - 93	GOBO MOTOR RESET
	94 - 96	SHUTTER/DIMMER MOTOR RESET
	97 - 99	OTHER MOTOR RESET
	100 - 119	INTERNAL PROGRAM 1
	120 - 139	INTERNAL PROGRAM 2
	140 - 159	INTERNAL PROGRAM 3
	160 - 179	INTERNAL PROGRAM 4
	180 - 199	INTERNAL PROGRAM 5
200 - 219	INTERNAL PROGRAM 6	
220 - 239	INTERNAL PROGRAM 7	
240 - 255	SOUND ACTIVE PROGRAM	

## Vizi Roller Beam 2R

## Lamp Replacement

**Caution:** Always replace with the exact same type lamp and fuse, unless otherwise specified by an authorized ADJ service technician. Replacing with anything other than the specified part can damage your unit and will void your manufactures warranty.

**Warning:** If you continue to blow lamps or fuses, STOP using the unit. Contact customer support for further instructions, you may have to return the unit for servicing. Continuing to use the unit may cause serious damage.

**Lamp Replacement:** Caution! Never attempt to change the lamp while the fixture is plugged in. Always disconnect the main power and allow the unit ample time to cool before attempting to replace the lamp. Please see page 7 for important information regarding the discharge lamp. **Do not handle the lamps with with bare hands!**

1. Be sure to follow the proper handling procedures that deal with discharge lamps.
2. Remove the three small screws (labeled A, B, & C) on the bottom of the unit.
3. After removing the screws, gently remove the lamp access panel.
4. **Carefully** disconnect the two wires connected to the lamp (Pic A).
5. Next, located on the left side squeeze the lamp holding clips together and lift the holder (Pic B).
6. Replace the lamp with an exact match. Reassemble in reverse order. Clear the lamp time after replacing the lamp.

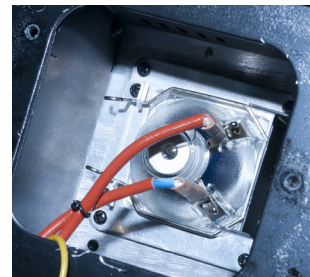

Pic A

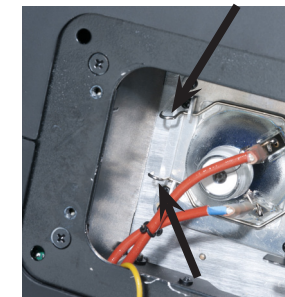

Pic B

**Fuse Replacement:** Locate and remove the unit's power cord. Once the cord has been removed located the fuse holder located inside the power socket. Insert a flat-head screw driver into the power socket and gently pry out the fuse holder. Remove the bad fuse and replace with a new one. The fuse holder has a built-in socket for a spare fuse be sure not to confuse the spare fuse with active fuse.

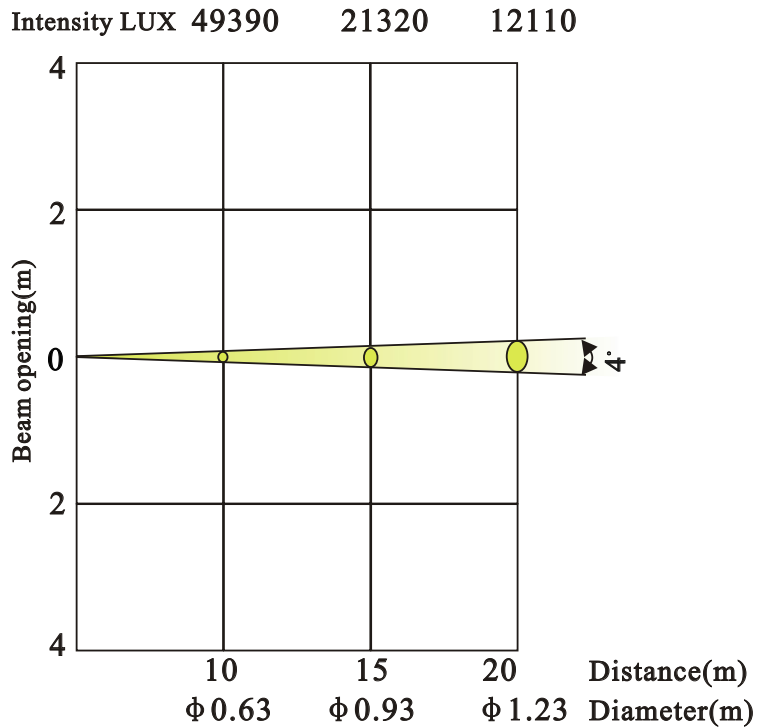

**Fixture Cleaning:** Due to fog residue, smoke, and dust cleaning the internal and external optical lenses and mirror should be carried out periodically to optimize light output. Cleaning frequency depends on the environment in which the fixture operates (i.e. smoke, fog residue, dust, dew). In heavy club use we recommend cleaning on a monthly basis. Periodic cleaning will ensure longevity, and crisp output.

1. Use normal glass cleaner and a soft cloth to wipe down the outside casing.
2. Use a brush to wipe down the cooling vents and fan grill.
3. Clean the external optics and mirror with glass cleaner and a soft cloth every 20 days.
4. Clean the internal optics with glass cleaner and a soft cloth every 30-60 days.
5. Always be sure to dry all parts completely before plugging the unit back in.

**Trouble Shooting:** Listed below are a few common problems that you may encounter, with solutions.

***No light output from the unit;***

1. Be sure the external fuse has not blown. The fuse is located on the bottom panel of the unit.
2. Remove the lamp holder and be sure the lamp is seated in its socket properly. Occasionally lamps become loose during shipping be sure the lamp is push in to its socket all the way.
3. Be sure the fuse holder is completely and properly seated.

***Unit does not respond to sound;***

1. Low frequencies (bass) should cause the unit to react to sound. Tapping on the microphone, quiet or high pitched sounds may not activate the unit.



## MANUFACTURER'S LIMITED WARRANTY

- A. ADJ Products, LLC hereby warrants, to the original purchaser, ADJ Products, LLC products to be free of manufacturing defects in material and workmanship for a prescribed period from the date of purchase (see specific warranty period on reverse). This warranty shall be valid only if the product is purchased within the United States of America, including possessions and territories. It is the owner's responsibility to establish the date and place of purchase by acceptable evidence, at the time service is sought.
- B. **For warranty service you must obtain a Return Authorization number (RA#) before sending back the product—please contact ADJ Products, LLC Service Department at 800-322-6337.** Send the product only to the ADJ Products, LLC factory. All shipping charges must be pre-paid. If the requested repairs or service (including parts replacement) are within the terms of this warranty, ADJ Products, LLC will pay return shipping charges only to a designated point within the United States. If the entire instrument is sent, it must be shipped in its original package. No accessories should be shipped with the product. If any accessories are shipped with the product, ADJ Products, LLC shall have no liability whatsoever for loss of or damage to any such accessories, nor for the safe return thereof.
- C. This warranty is void if the serial number has been altered or removed; if the product is modified in any manner which ADJ Products, LLC concludes, after inspection, affects the reliability of the product; if the product has been repaired or serviced by anyone other than the ADJ Products, LLC factory unless prior written authorization was issued to purchaser by ADJ Products, LLC; if the product is damaged because not properly maintained as set forth in the instruction manual.
- D. This is not a service contract, and this warranty does not include maintenance, cleaning or periodic check up. During the period specified above, ADJ Products, LLC will replace defective parts at its expense with new or refurbished parts, and will absorb all expenses for warranty service and repair labor by reason of defects in material or workmanship. The sole responsibility of ADJ Products, LLC under this warranty shall be limited to the repair of the product, or replacement thereof, including parts, at the sole discretion of ADJ Products, LLC. All products covered by this warranty were manufactured after August 15, 2012, and bear indentifying marks to that effect.
- E. ADJ Products, LLC reserves the right to make changes in design and/or improvements upon its products without any obligation to include these changes in any products theretofore manufactured.

No warranty, whether expressed or implied, is given or made with respect to any accessory supplied with products described above. Except to the extent prohibited by applicable law, all implied warranties made by ADJ Products, LLC in connection with this product, including warranties of merchantability or fitness, are limited in duration to the warranty period set forth above. And no warranties, whether expressed or implied, including warranties of merchantability or fitness, shall apply to this product after said period has expired. The consumer's and/or Dealer's sole remedy shall be such repair or replacement as is expressly provided above; and under no circumstances shall ADJ Products, LLC be liable for any loss or damage, direct or consequential, arising out of the use of, or inability to use, this product.

This warranty is the only written warranty applicable to ADJ Products, LLC Products and supersedes all prior warranties and written descriptions of warranty terms and conditions heretofore published.

## MANUFACTURER'S LIMITED WARRANTY PERIODS:

- **Lighting Products = 1-year (365 days) Limited Warranty** (Such as: Special Effect Lighting, Intelligent Lighting, UV lighting, Stobes, Fog Machines, Bubble Machines, Mirror Balls, Par Cans, Trussing, Lighting Stands etc. excluding LED and lamps)
- **Laser Products = 90-Day Limited Warranty**
- **L.E.D. Products = 2-year (730 days) Limited Warranty** (excluding motors, PCB boards, and power supplies, which have a 1-year (365 day Limited Warranty) and batteries which have a 180 day limited warranty).

<b>Model:</b>	<b>Vizi Roller Beam 2R</b>
<b>Voltage:</b>	100~240V, 50/60Hz
<b>Lamp:</b>	Philips® Platinum MSD 2R Discharge
<b>Power Consumption:</b>	210W
<b>Dimensions:</b>	17.5”(L) x 12”(W) x 9.25”(H) 439.7mm x 300mm x 233.4mm
<b>Weight:</b>	16.75 Lbs. / 7.5 kgs.
<b>Colors:</b>	13 Plus White
<b>Gobos:</b>	8 + 6 Spots
<b>Fuse:</b>	4A
<b>Duty Cycle:</b>	None
<b>DMX:</b>	3 DMX Channel Modes: 11 Channels, 13 Channels, or 18 Channels
<b>Sound Active:</b>	Yes
<b>Working Position:</b>	Any Safe, Secure Position
<b>Warranty:</b>	1 Year (365 days)

**Auto Sensing Voltage:** *This fixture contains a electronic ballast, which will auto sense the voltage when it is plugged into the power source.*

**Please Note:** *Specifications and improvements in the design of this unit and this manual are subject to change without any prior written notice.*

ADJ Products, LLC  
6122 S. Eastern Ave. Los Angeles, CA 90040 USA  
Tel: 323-582-2650 / Fax: 323-725-6100  
Web: [www.adj.com](http://www.adj.com) / E-mail: [info@americandj.com](mailto:info@americandj.com)

A.D.J. Supply Europe B.V.  
Junostraat 2  
6468 EW Kerkrade  
Netherlands

Follow Us On:



[facebook.com/americandj](https://facebook.com/americandj)  
[twitter.com/americandj](https://twitter.com/americandj)  
[youtube.com/adjlighting](https://youtube.com/adjlighting)

[service@adjgroup.eu](mailto:service@adjgroup.eu) / [www.adj.eu](http://www.adj.eu)  
Tel: +31 45 546 85 00 / Fax: +31 45 546 85 99