

## DR128 in an Audio/Visual Conference Suite

This technical article provides a case study of the DR128's application for an A/V installation. The installation in case is one of a series of council office conference suites designed and installed by Innovatec's David Thompson and George Guthrie. The client's requirement for this project was for easy-to-use but comprehensive A/V facilities in a large conference suite. In addition to standard conferencing facilities, a large video screen is provided to support A/V presentation from PCs, laptops, VCRs, slide-projectors, overhead-camera projectors – with all their associated audio

### sources ■ System Outline

Innovatec has developed a reputation for innovative state-of-the-art installation using high-quality system components, and their solution here was no different. Remote control of all necessary functions was provided by an AMX LCD

Touch-screen remote control unit while audio routing was controlled and integrated using the DR128.

For conference applications sound reinforcement is provided by numerous ceiling speakers on a 100V-line system, where a dedicated Philips conferencing system provides the required prioritised Mic inputs and voting system. For A/V applications a large screen projector system is supported by main left/right sound reinforcement loud-speakers and ceiling speakers, with the balance in favour of the mains to focus attention on the screen ■

### DR128 Configuration

Figure 1 shows the audio routing through the DR128 and Figure 2 shows the internal routing configuration of the DR128 for this application. Internally all DR128 inputs were set at line level sensitivity, with outputs set at 4dBu ■

### Floor Boxes

DR128 inputs 1-4 are fed from balanced XLR line inputs provided from recessed floor boxes distributed around the room. The floor boxes also provide connections for composite video and audio feeds from VCRs; RGB plus audio inputs for laptops and PCs, mains-voltage, and access to the organisation's network server. Two additional wall panels provide additional composite and RGB audio/video inputs. The composite and RGB audio/video inputs feed two 8:1 audio/video switchers so that audio and video can be switched together under AMX remote control ■

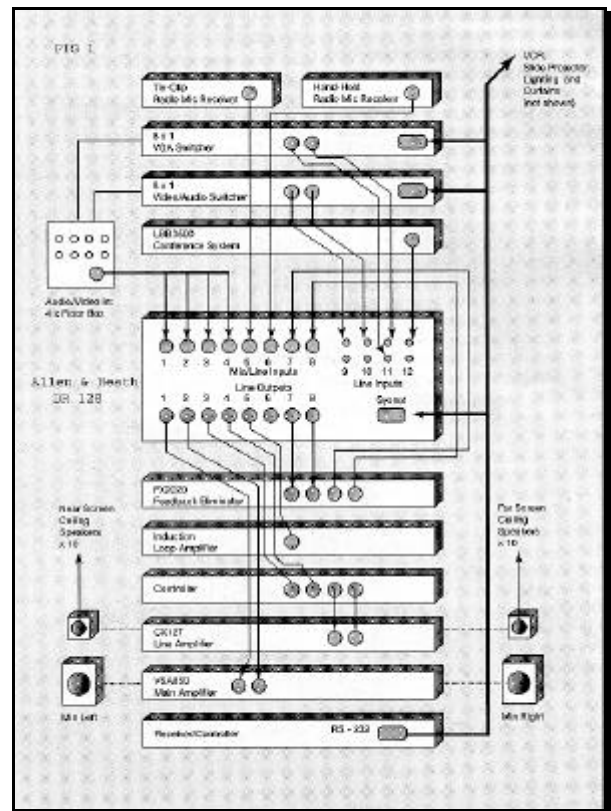

## DR128 Inputs

DR128 inputs 5 and 6 are fed from two radio-mic receiver units for inputs from tie-clip and hand-held radio microphones. Inputs 7 and 8 are fed from the stereo output of the dual feed-back eliminator (discussed below). Inputs 9 and 10 are fed from the audio stereo outputs of the composite Video switcher, while the stereo RGB switcher audio outputs are summed to mono at the DR128's input 11. Finally input 12 is fed from the conference system output

## Feedback Elimination

As shown in Fig 2, inputs 1 to 5 and 9 to 12 are first sub-mixed to a stereo pair at outputs 7 and 8. This is in turn

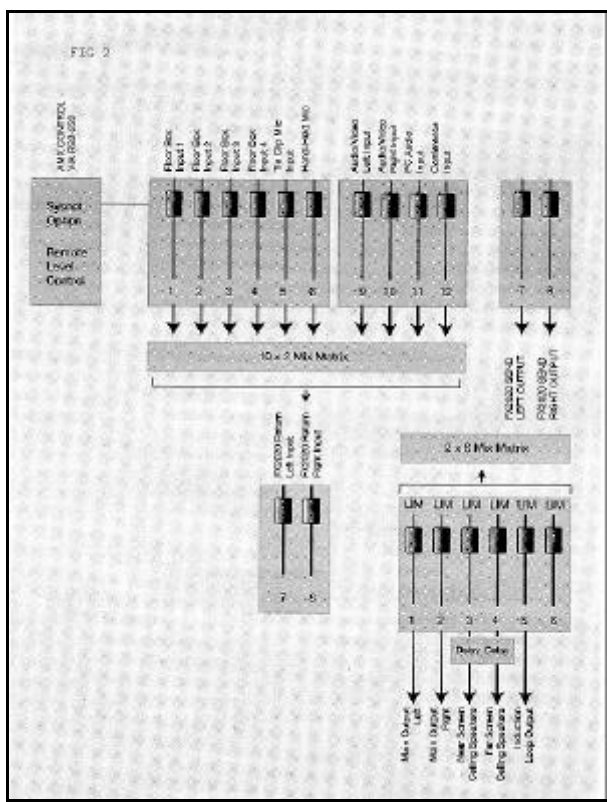

fed to a Sabine FX2020 dual feedback eliminator, whose stereo outputs are fed back to DR128 inputs 7 and 8. The FX2020 was configured to notch out known troublesome resonant feedback frequencies from the Mic inputs thus making the system 'feedback-proof'.

## DR128 Outputs

Stereo inputs 7 and 8 are then sub-mixed to outputs 1 to 6. All outputs first pass through the DR128's protection limiters. These were set to a fast attack time, medium release with a low threshold setting. The limiters therefore provide protection for the loudspeakers and amplifiers from any serious 'system abuse'.

DR128 outputs 1 and 2 provide a stereo feed to the QSC amplifier for driving the main left/right front-of-house loudspeakers. Outputs 3 and 4 provide two mono feeds to the QSC line amplifier feeding 2 zones of ceiling

loudspeakers (see below). Output 5 feeds a mono signal to the induction-loop amplifier which provides monitoring for the hard-of-hearing

## Delay

For A/V presentations the mains are switched in to provide focus to the front of the room, while the ceiling speakers are at a lower level to provide general sound reinforcement. Because of the large size of the room the sound delay between the mains and the ceiling speakers at the back of the room was apparent. The room was therefore partitioned into three zones: 2 mains for front video screen, ten near-screen ceiling speakers, and ten far-screen ceiling speakers. The DSPx Delay Option card was therefore fitted to the DR128 to provide a small delay to the near-screen ceiling speakers, and a larger delay for the far-screen ceiling speakers. This provided clear, natural, sound reinforcement

## Patches and Function Keys

Two of the DR128's sixteen patches were used for this application, to switch between conference and A/V modes. For Patch 1: conference mode, only the ceiling speakers are in use and the zone-delays are set to zero. For Patch 2: A/V mode the main left right front-of-house speakers are switched in with a lower level feeds to the delayed ceiling speaker zones.

To provide easy system setup and modification the DR128's front panel Function Keys were configured as shown in Table 1. This assignment allows up/down level control over all of the DR128's input signals on keys F1 to F10. Keys F11 and F12 allow the configuration patches mentioned above to be activated.

Finally the DR128's password protection was enabled to stop any unwanted tampering with the system setup ■

## Remote Control

All of the above power and flexibility is in vain if the customer can't use it. System control for the user is provided by an AMX LCD Touch-screen.

F1	Tie Clip Mic Input Level Up/Down
F2	Hand-held Mic Input Level
F3	Floor Box 1 Input Level Up/Down
F4	" 2 "
F5	" 3 "
F6	" 4 "
F7	VCR Audio Left Input Level Up/Down
F8	VCR Audio Right Input Level Up/Down
F9	PC Audio Left Input Level Up/Down
F10	Conference Input Level Up/Down
F11	Patch 1 – Conference Mode
F12	Patch 2 – A/V Mode

Table 1 DR128 Function Key Assignments

This was programmed by Innovatec to provide easy-to-use switching between audio/video sources, audio configuration (via the DR128's patches), audio input level control, room lighting control, recessed video screen activation, and curtain control.

The touch-screen communicates via a radio link to the AMX Axcent-2 receiver in the equipment rack. This then controls the audio/video switchers, slide projector, VCR lighting and curtains using RS-232 feeds (see Fig 1). For the DR128 a SysNet Option card was fitted allowing individual remote control of all of the DR128's input channel levels. The configuration Patches can also be recalled via SysNet ■

## DR128 Expansion

For the above application the power and flexibility of the DR128 is apparent. However the DR128 provides still further features that may be called upon as the system develops. For example, the DR128 still has a DSP free for any additional signal processing such as Parametric EQ, Graphic EQ, Gates and Compressors. Compressors could be applied to temper any unruly Mic sources, while Gates would be useful for noisy audio signals from PCs.

Regarding the application of EQ, Innovatec apply the principle of 'if it ain't broken don't fix it'; David Thomson: "As it happens, no EQ was required because with the high-quality components used, and a well-behaved room, the system sounds great as it is".

Future applications may require the DR128's internal Ducker system to be employed. For example, a speaker with a tie-clip may want to talk over a video presentation. The Ducker would be programmed to attenuate all audio input signals to outputs 7 and 8 when speech is detected on the microphone input channel ■

## Conclusion

The above application shows how the DR128 forms the hub of the audio processing in such a system. As such it provides all the zone mixing, routing, signal processing and remote control facilities in compact and flexible 2U rack space. David Thomson again : "For this application the alternative would have required using a bulky automated mixing console which wouldn't fit into the tight equipment cupboard and would require additional expense of control via MIDI". Innovatec's solution has therefore provided a system providing remote control over 16 video and 22 audio sources, and still with room for future expansion! ■



Allen & Heath  
Kernick Industrial Estate  
Penryn, Cornwall, England TR10 9LU  
T +44 (0) 1326 372 070  
F +44 (0) 1326 377097  
Website: <http://www.allen-heath.com>

 A Harman International Company