



General Description

The Rane MLM 82a features four balanced, studio grade, Mono Mic/Line Inputs with XLR jacks and 15 VDC phantom power. *Each of the four Mic/Line Inputs may be assigned to A, A+B or B Outputs.* Independent Level/Gain Trim controls and Signal/Overload indicators are provided for each Mic/Line Input. The Phantom Power switch and the Mic/Line switches are located on the rear panel. Phantom power is removed from any Input set for Line operation.

The MLM 82a also features four stereo line level inputs with 12 dB of line gain. Each Stereo Line Input features a recessed Mono switch with indicator and Level control. These

Inputs may also be used with four Mono A Inputs and four Mono B Inputs. You get the picture... this mixer is very versatile.

A and B Output Level controls set the master mix level independently for A and B Outputs. The mix amplifiers feature independent overload indicators. To correct any overload condition, the entire mix can be reduced and/or individual Input Levels adjusted. A and B mix Outputs each have an internal switch for padding the output signal to Mic level. The factory default is Line level.

Features

- Four balanced Mic/Line Inputs (XLR) with...
 - 15 volt phantom power
 - Bi-Color Signal Present/Overload indicators
 - Trimless Mic Stage Preamplifiers
 - A / A+B / B assign switch
- Four balanced, Stereo Line Inputs (TRS) with...
 - Independent Mono switch
 - 12 dB of line gain
- Two balanced Outputs (XLR) with...
 - Independent Overload indicators
 - Independent Level controls
 - Internal Pad for Mic level output
- Individual Level control hole plugs included
- UL/CSA/CE and 100/120/230 VAC Remote Power Supplies



Features and Specifications

Parameter	Specification	Limit	Units	Conditions/Comments
Inputs: Type	Active Balanced			
.....Connectors	XLR / ¼" TRS			Mic / Stereo Line
Mic / Line Input Impedance	1k / 96k	1%	Ω	Balanced 500+500 / 48k + 48k
.....Mic Gain Range	off to +60	±1.5	dB	
.....Line Gain Range	off to +20	±1.5	dB	
.....Equivalent Input Noise	-128	typ	dBu	20 kHz bandwidth, 150 Ω termination
.....THD & Noise	0.02	max	%	Gain=40 dB, +4 dBu @ 1 kHz, 80 Hz BW
.....Frequency Response	30 Hz - 35 kHz	-3	dB	
Stereo Line Input Impedance	20k	min	Ω	
.....Gain Range	off to +12	±1	dB	
.....Signal-To-Noise Ratio	90	typ	dB	Unity gain, output @ +4 dBu, 22 kHz BW
.....Frequency Response	10 Hz - 35 kHz	-3	dB	
.....THD & Noise	0.007	max	%	+4 dBu at 1 kHz, 80 kHz BW
Outputs: Type	Active Balanced			
.....Connectors	XLR			
.....Impedance	200/100	1%	Ω	Line level Out/Mic level Out
.....Gain Range	Off to +6	±2	dB	
.....Drive Level	+24		dBu	600 Ω load balanced
Phantom Power	+15	4%	VDC	
Output Cable Length	1500	typ	feet	Line-level, <50 pF per foot
Crosstalk	-75 @ 1 kHz	max	dB	re +4 dBu any channel to any channel
Unit: Agency Listing				
.....120 VAC model	Class 2 Equipment			National Electrical Code
	UL			Exempt Class 2 equipment
	CSA			Exempt Class 2 equipment
.....230 VAC model	CE-EMC			EMC directive 89/336/EEC
	CE-Safety			Exempt per Art. 1 of LVD 73/23/EEC
Power Supply: Agency Listing				Class 2 Equipment
.....120 VAC model	UL			File no. E88261
	CSA			File no. LR58948
.....230 VAC model	CE-EMC			EMC directive 89/336/EEC
	CE-Safety			LV directive 73/23/EEC
Power Supply Requirement	18 VAC w/center tap	10%	Vrms	RS 1 (see data sheet)
.....Maximum Current	600		mA	RMS Current from Remote Supply
Unit: Construction	All Steel			
.....Size	1.75"H x 19"W x 5.3"D (1U)			(4.4 cm x 48.3 cm x 13.3 cm)
.....Weight	4 lb			(3 kg)
Shipping: Size	4.25" x 20.3" x 13.75"			(11 cm x 52 cm x 35 cm)
.....Weight	8 lb			(5 kg)
<i>Note: 0 dBu=0.775 Vrms</i>				

Block Diagram

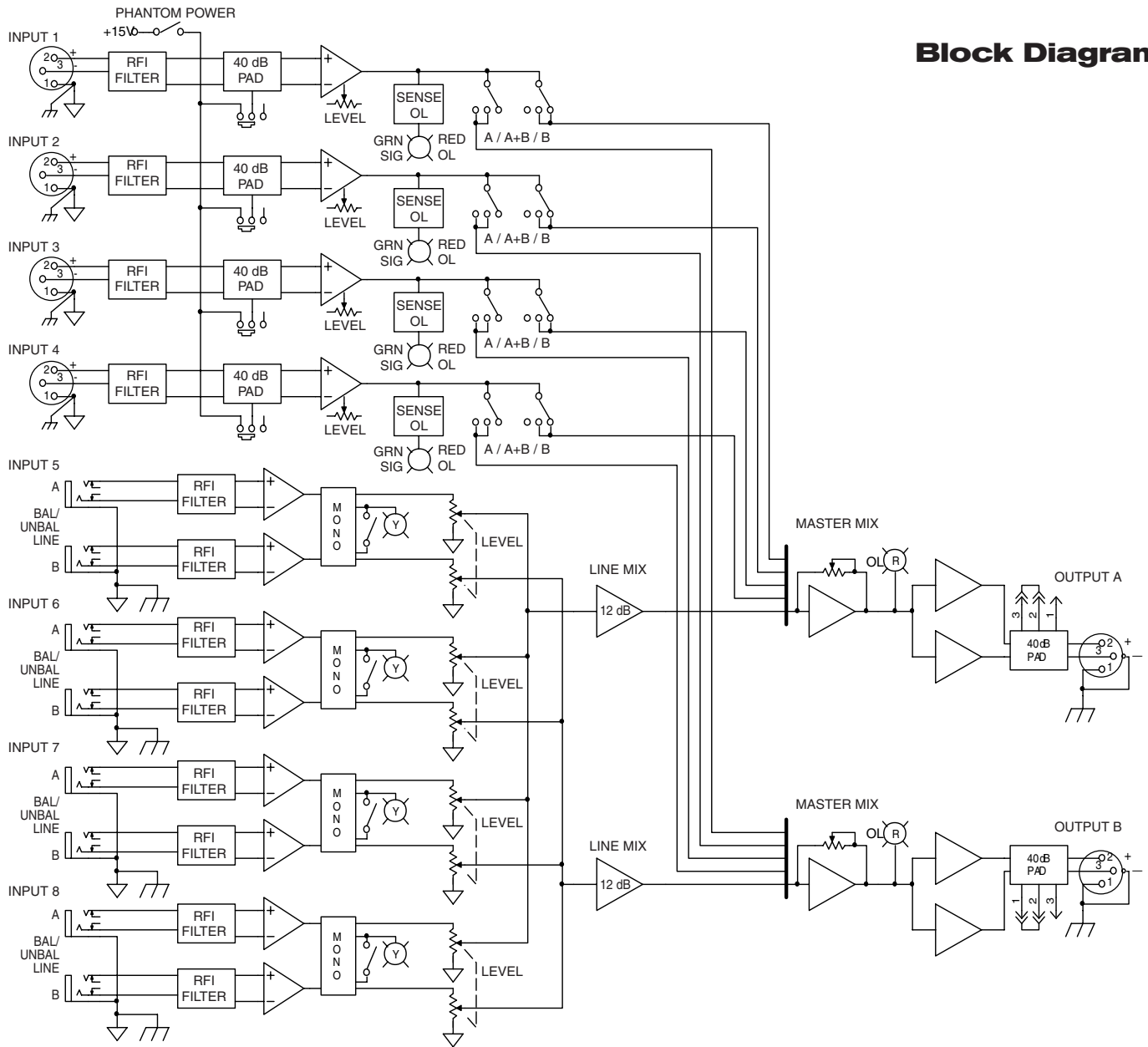

Applications

With features like Mic/Line A / A+B / B Assign switches, independent Stereo Line Input Mono switches and additional line gain, the MLM 82a is now one of the most versatile mixers in its class. It is ideal for installations requiring ease of use, compact size, low cost, high performance and security. Applications include, but are not limited too, hotels, churches, conference rooms, schools and rental sound systems. The

studio-grade specifications of the MLM 82a allow many other applications such as sub-mixing, recording and post-production.

The Mic/Line Assign switches and independent Mono switches for each of the Stereo Line Inputs make the MLM 82a a true, dual zone capable mixer, i.e., the Outputs may be thought of as two independent zones or a single stereo zone.

MLM 82a

MIC/LINE MIXER



Rear Panel

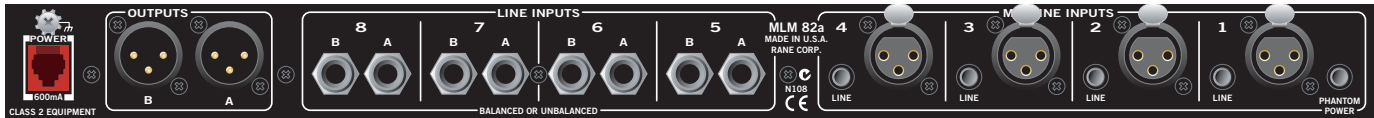

Architectural Specifications

The mixer shall have four studio-grade mono mic/line inputs each with XLR input jack, 15 V phantom power, line pad, A / A+B / B mix assign switch, level control and signal/overload indicator. A single switch shall make phantom power available to all four microphone inputs. Phantom power shall be removed automatically from any mic/line input set for line input. For ease of use, mic/line preamplifiers shall use a single control for input gain trim and mix level.

The mixer shall feature four stereo line inputs each with 1/4" TRS input jack, level control and pre-level control mono switch. The inputs shall provide for dual mono operation with four mono signals available for the A mix and four mono inputs available for the B mix.

A and B mix outputs shall feature overload indicators, independent A/B level controls, internally selected 40 dB pad

for microphone level output and XLR output jacks.

Security features shall include placement of the phantom power and line switches on the rear panel, recessed assign switches, internally located pad switch for selecting line or microphone output level and recessed stereo line input mono switches with position indicators. In addition, each of the front panel level control knobs may be removed and replaced with a security plug. Four security plugs shall be provided for this purpose.

The unit shall be exempt from agency safety requirements and powered from a UL listed / CSA certified (120 VAC), or CE approved (230 VAC) remote power supply. The unit shall be constructed of cold-rolled steel and mount into a standard 19" 1U EIA rack.

The unit shall be a Rane MLM 82a Mic/Line Mixer.

Available Accessories

- SC 1.7 Single Space Security Cover