

Tensioned Large Advantage® Electrol®

Automatic Electric Projection Screen Model



SPECIFICATION DATA

SUGGESTED SPECIFICATIONS: _____ projection screen(s), _____(H) x _____(W), electrically operated 120 volt (60 Hz) not more than 2.4 amp. with a quick connect male plug-in connector on the motor. Shall have specially designed motor mounted inside the roller, to be three wire with ground, quick reversal type, oiled for life, with automatic thermal overload cutout, integral gears, capacitor and an electric brake to prevent coasting. To have preset but adjustable limit switches to automatically stop picture surface in the "up" and "down" positions. Junction box shall be internally integrated into the housing making it possible to install the housing and wire to the building's electrical system during construction. The junction box shall contain a quick connect connector that is mounted in the housing for easy plug-in connection to the motorized fabric and roller assembly. The motorized fabric and roller assembly to be installed in the case at the factory or at a later time at the job site. The fabric roller to be of 4½" diameter (5¾" if 270" diagonal, 275" diagonal, or 298" diagonal) metal. Screen to be designed for left or right-hand motor

installation. Screen fabric to be seamless, flame retardant and mildew resistant vinyl with black masking borders standard. Each side of the fabric to have tab guide cable system to maintain even lateral tension and hold surface flat. Custom slat bar with added weight maintains vertical tension on the screen surface. The ends of the slat to be protected by heavy duty plastic caps enclosing a preset adjustable mechanism for screen tensioning. Case to be made of extruded aluminum powder coated white. End caps to be of heavy gauge steel powder coated white. Bottom of case to have a removable access door. Door to be of extruded aluminum powder coated white. Bottom of case to be self-trimming, with a built-in flange around the bottom of the case. To be complete with integrated low voltage control unit and three position control switch with cover plate. Suitable for use in environmental air space in accordance with section 300-22 (c) of the National Electric Code, and sections 2-128, 12-010 (3) and 12-100 of the Canadian Electrical Code, part 1, CSA C22.1. Screen to be listed by Underwriters' Laboratories.



HDTV (16:9) Format Dimensions

Viewing Area (H x W)		Nominal Diagonal		Overall Length of Case*		Approx. Ship. Wt.	
In.	Cm	In.	Cm	In.	Cm	Lbs.	Kg
108" x 192"	274 x 488	220"	559	221½"	562	652	295.7
121" x 216"	307 x 549	247"	627	247½"	628	727	329.8
135" x 240"	343 x 610	275"	699	273½"	694	803	364.2
146" x 260"	371 x 660	298"	757	294½"	748	847	384.2

Wide (16:10) Format Dimensions

Viewing Area (H x W)		Nominal Diagonal		Overall Length of Case*		Approx. Ship. Wt.	
In.	Cm	In.	Cm	In.	Cm	Lbs.	Kg
110" x 176"	279 x 447	208"	528	205½"	523	691	313.4
120" x 192"	305 x 488	226"	574	222½"	565	729	330.7

Video (NTSC 4:3) Format Dimensions

Viewing Area (H x W)		Nominal Diagonal		Overall Length of Case*		Approx. Ship. Wt.	
In.	Cm	In.	Cm	In.	Cm	Lbs.	Kg
126" x 168"	320 x 427	210"	533	199½"	507	594	269.4
132" x 176"	335 x 447	220"	559	208½"	530	620	281.2
144" x 192"	366 x 488	240"	610	226½"	574	672	304.8
162" x 216"	411 x 549	270"	686	251½"	639	744	337.5

*Case length does not include flange

PRODUCT NOTES

- All surfaces will be seamless.
- All viewing surfaces are standard with black backing except Da-Tex® and Dual Vision.
- All screens standard with 12" black drop at the top except 270" diagonal, which has 2".
- Extra drop may alter case dimensions. Contact Da-Lite for details.
- Overall case length dimensions +/- ¼".
- Detail dimensional drawings, wiring diagrams and installation instructions available upon request.
- Specifications subject to change without notice.
- Custom formats and sizes available upon request.

WHEN ORDERING, MARK APPROPRIATE SELECTIONS

- Select size from charts on the other side.
- Select viewing surface (All Da-Lite surfaces are GREENGUARD GOLD Certified):

<input type="checkbox"/> HD Progressive 0.6	<input type="checkbox"/> Dual Vision
<input type="checkbox"/> HD Progressive 0.9	<input type="checkbox"/> High Contrast Cinema Vision
<input type="checkbox"/> HD Progressive 1.1	<input type="checkbox"/> Cinema Vision
<input type="checkbox"/> HD Progressive 1.3	<input type="checkbox"/> Pearlescent
<input type="checkbox"/> Da-Mat®	<input type="checkbox"/> Da-Tex® (Rear)
<input type="checkbox"/> High Contrast Da-Mat®	
- Optional accessories:

<input type="checkbox"/> Wireless Remote Control for LVC.	<input type="checkbox"/> Key Locking Cover Plate for LVC Switch.
<input type="checkbox"/> Radio Frequency Remote.	<input type="checkbox"/> 220 Volt (50 Hz) Motor.
<input type="checkbox"/> Radio Frequency Range Extender available.	<input type="checkbox"/> SCB-100 RS-232 Serial Control Board - built in.
<input type="checkbox"/> Infrared Remote.	<input type="checkbox"/> NET-100 Ethernet-Serial Adapter

PRODUCT VIEWS

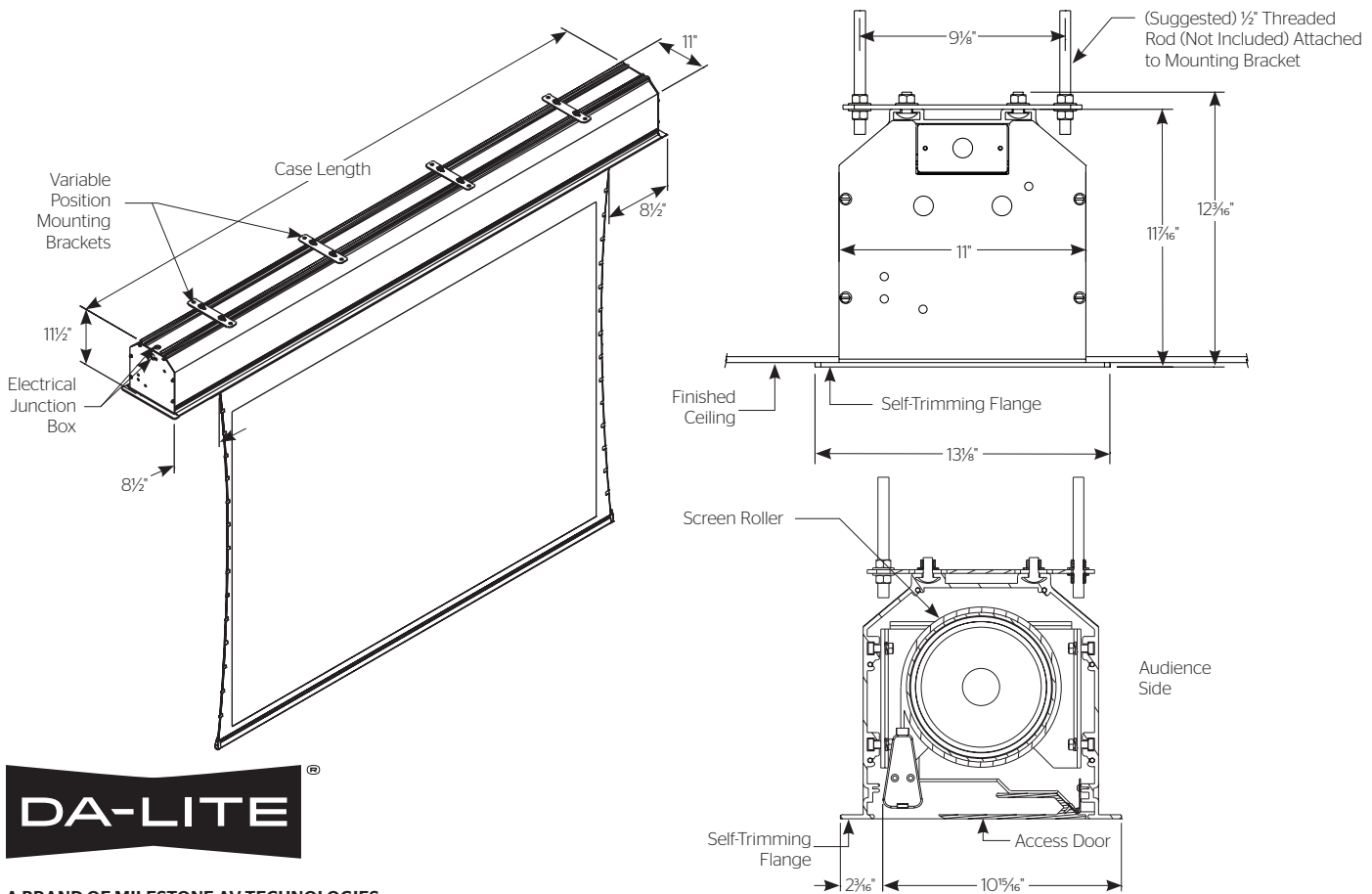

A BRAND OF MILESTONE AV TECHNOLOGIES

www.milestone.com
 P 800.622.3737 / 574.267.8101
 F 877.325.4832 / 574.267.7804
 E info@da-lite.com

In British Columbia, Milestone AV Technologies ULC carries on business as MAVT Milestone AV Technologies ULC.

©2016 Milestone AV Technologies. DL-0197 (Rev. 4) 01.17.
 Da-Lite is a registered trademark of Milestone AV Technologies. All other brand names or marks are used for identification purposes and are trademarks of their respective owners. All patents are protected under existing designations. Other patents pending.

Project Name: _____	
Architect: _____	Phone: _____
Contractor: _____	Phone: _____
Supervisor: _____	Phone: _____
Supplier: _____	Date: _____
Revised: _____	