

GENERAL CHARACTERISTICS		
Nominal Overall Diameter	307 mm.	12 in.
Nominal Voice Coil Diameter	38 mm.	1.50 in.
Magnet Weight	826 g	29.00 oz
Overall Weight		6.83 lbs
Flux Density		1.26 T
Voice Coil Winding Depth		0.39 in.
Magnetic Gap Depth		0.31 in.

THIELE-SMALL PARAMETERS			
		8Ω	16Ω
Voice Coil DC Resistance	R_E	6.03	12.00
Resonance Frequency	f_S	90.0	91.0
Mechanical Q Factor	Q_{MS}	4.36	5.77
Electrical Q Factor	Q_{ES}	0.82	0.98
Total Q Factor	Q_{TS}	0.77	0.84
Mechanical Moving Mass	M_{MS}	30.9	27.0
Mechanical Compliance	C_{MS}	101	125
Force Factor	$B \times L$	10.62	13.71
Equivalent Acoustic Volume	V_{AS}	34.6	42.2
Maximum Linear Displacement	X_{MAX}	1.00	1.00
Reference Efficiency	η_0	3.40	2.84
Diaphragm Area	S_D	490.9	490.8
Losses Electrical Resistance	R_{ES}	43.0	70.0
Voice Coil Inductance @ 1kHz	L_E	0.87	1.05

CONSTRUCTIVE CHARACTERISTICS	
Magnet	Alnico
Voice Coil Winding	Copper
Voice Coil Former	Kapton
Cone Material	Paper
Surround Material	Integrated Paper
Dust Dome Material	Solid Paper
Basket Material	Pressed Sheet Steel
Surround Treatment	No

ELECTRICAL CHARACTERISTICS		
	8Ω	16Ω
Nominal Impedance	8	16
Rated Power	50	50
Musical Power	100	100
Sensitivity@1W,1m	97.5	97.8

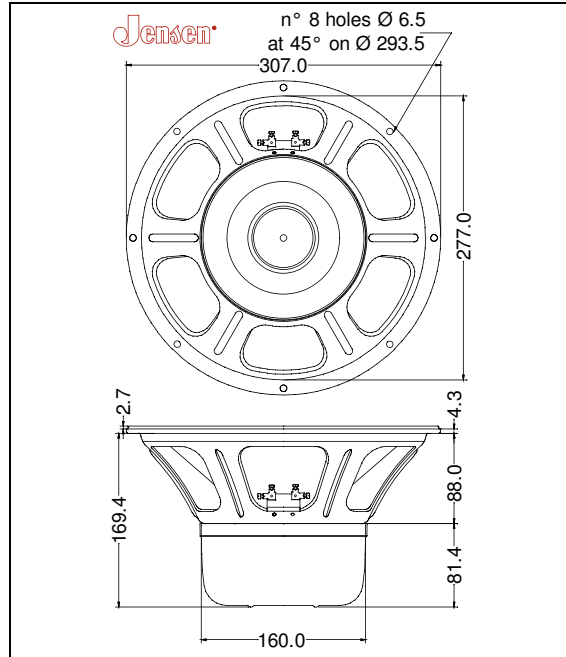

Frequency Response on IEC Baffle (DIN 45575) @ 1W, 1m - Free Air Impedance

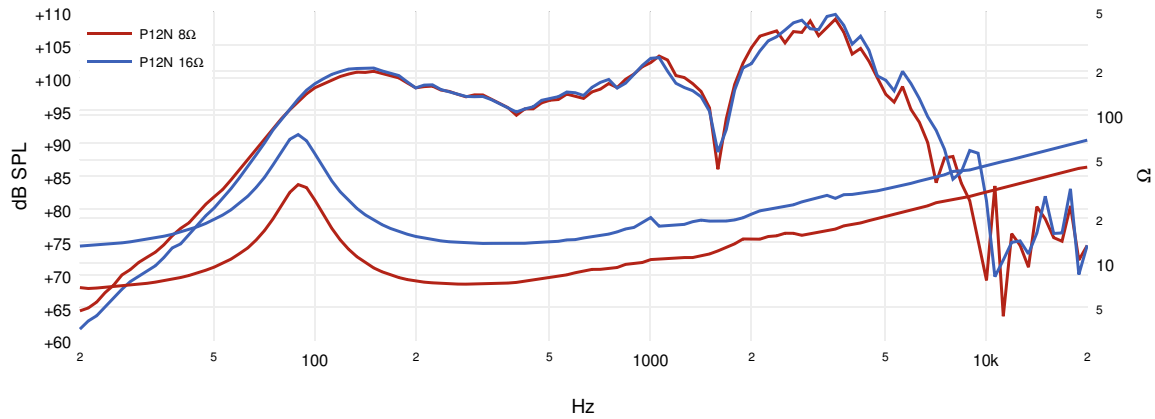

Due to continuing product improvement, the features and the design are subject to change without notice.