

# AUDIOHUB 2x4



**USER GUIDE**

FFFA001115-03

Novation

A division of Focusrite Audio Engineering Ltd.

Windsor House,

Turnpike Road,

Cressex Business Park,

High Wycombe,

Bucks,

HP12 3FX

United Kingdom

Tel: +44 1494 462246

Fax: +44 1494 459920

e-mail: [sales@novationmusic.com](mailto:sales@novationmusic.com)

Web: <http://www.novationmusic.com>

## **Trademarks**

The Novation trademark is owned by Focusrite Audio Engineering Ltd. All other brand, product and company names and any other registered names or trade marks mentioned in this manual belong to their respective owners.

## **Disclaimer**

Novation has taken all possible steps to ensure that the information given here is both correct and complete. In no event can Novation accept any liability or responsibility for any loss or damage to the owner of the equipment, any third party, or any equipment which may result from use of this manual or the equipment which it describes. The information provided in this document may be modified at any time without prior warning. Specifications and appearance may differ from those listed and illustrated.

# IMPORTANT SAFETY INSTRUCTIONS

1. Read these instructions.
2. Keep these instructions.
3. Heed all warnings.
4. Follow all instructions.
5. Do not use this apparatus with water.
6. Clean only with dry cloth.
7. Do not install near any heat sources such as radiators, heat registers, stoves, or other apparatus (including amplifiers) that produce heat.
8. Protect the power cord from being walked on or pinched particularly at plugs, convenience receptacles, and the point where they exit from the apparatus.
9. Only use attachments/accessories specified by the manufacturer.
10.  Use only with the cart, stand, tripod, bracket, or table specified by the manufacturer, or sold with the apparatus. When a cart is used, use caution when moving the cart/apparatus combination to avoid injury from tip-over.
11. Unplug this apparatus during lightning storms or when unused for long periods of time.
12. Refer all servicing to qualified service personnel. Servicing is required when the apparatus has been damaged in any way, such as power-supply cord or plug is damaged, liquid has been spilled or objects have fallen into the apparatus, the apparatus has been exposed to rain or moisture, does not operate normally, or has been dropped.
13. No naked flames, such as lighted candles, should be placed on the apparatus.

**WARNING:** This equipment must only be connected to USB 2.0 type ports.



**CAUTION:** TO REDUCE THE RISK OF ELECTRIC SHOCK, DO NOT REMOVE COVER (OR BACK). NO USER-SERVICEABLE PARTS INSIDE. REFER SERVICING TO QUALIFIED SERVICE PERSONNEL.



The lightning flash with arrowhead symbol, within equilateral triangle, is intended to alert the user to the presence of uninsulated “dangerous voltage” within the product’s enclosure that may be of sufficient magnitude to constitute a risk of electric shock to persons.



The exclamation point within an equilateral triangle is intended to alert the user to the presence of important operating and maintenance (servicing) instructions in the literature accompanying the appliance.

**WARNING:** TO REDUCE THE RISK OF FIRE OR ELECTRIC SHOCK, DO NOT EXPOSE THIS APPARATUS TO RAIN OR MOISTURE.

## ENVIRONMENTAL DECLARATION

Compliance Information Statement: Declaration of Compliance procedure	
Product Identification:	Novation Audiohub 2x4 audio interface
Responsible party:	American Music and Sound
Address:	4325 Executive Drive Suite 300 Southaven MS 38672
Telephone:	800-431-2609

This device complies with part 15 of the FCC Rules. Operation is subject to the following two conditions: (1) This device may not cause harmful interference, and (2) this device must accept any interference received, including interference that may cause undesired operation.

### For USA

#### To the User:

1. **Do not modify this unit!** This product, when installed as indicated in the instructions contained in this manual, meets FCC requirements. Modifications not expressly approved by Focusrite may void your authority, granted by the FCC, to use this product.
2. **Important:** This product satisfies FCC regulations when high quality shielded cables are used to connect with other equipment. Failure to use high quality shielded cables or to follow the installation instructions within this manual may cause magnetic interference with appliances such as radios and televisions and void your FCC authorization to use this product in the USA.

**Note:** This equipment has been tested and found to comply with the limits for a Class B digital device, pursuant to part 15 of the FCC Rules. These limits are designed to provide reasonable protection against harmful interference in a residential installation. This equipment generates, uses and can radiate radio frequency energy and, if not installed and used in accordance with the instructions, may cause harmful interference to radio communications. However, there is no guarantee that interference will not occur in a particular installation. If this equipment does cause harmful interference to radio or television reception, which can be determined by turning the equipment off and on, the user is encouraged to try to correct the interference by one or more of the following measures:

- Reorient or relocate the receiving antenna.
- Increase the separation between the equipment and receiver.
- Connect the equipment into an outlet on a circuit different from that to which the receiver is connected.
- Consult the dealer or an experienced radio/TV technician for help.

## For Canada

### To the User:

This Class B digital apparatus complies with Canadian ICES-003.

Cet appareil numérique de la classe B est conforme à la norme NMB-003 du Canada.

### RoHS Notice

Focusrite Audio Engineering Limited has conformed and this product conforms, where applicable, to the European Union's Directive 2002/95/EC on Restrictions of Hazardous Substances (RoHS) as well as the following sections of California law which refer to RoHS, namely sections 25214.10, 25214.10.2, and 58012, Health and Safety Code; Section 42475.2, Public Resources Code.

### CAUTION:

The normal operation of this product may be affected by a strong electrostatic discharge (ESD). In the event of this happening, simply reset the unit by removing and then replugging the USB cable. Normal operation should return.

## COPYRIGHT AND LEGAL NOTICES

Novation and Audiohub are registered trade marks of Focusrite Audio Engineering Limited.

2014 © Focusrite Audio Engineering Limited. All rights reserved.

# CONTENTS

IMPORTANT SAFETY INSTRUCTIONS .....	3
ENVIRONMENTAL DECLARATION .....	4
For USA .....	4
For Canada .....	5
COPYRIGHT AND LEGAL NOTICES .....	5
INTRODUCTION .....	7
Key Features .....	7
About This Manual .....	7
What's In The Box .....	8
Registering Your Audiohub 2x4 .....	9
Power Requirements .....	9
HARDWARE OVERVIEW .....	10
Front Panel .....	10
Rear Panel .....	11
Top Panel .....	12
Connecting Audiohub 2X4 To Your Computer .....	13
Audio Setup in your DAW .....	14
Connecting Audiohub 2x4 to your iPad .....	16
Using Input Monitoring .....	16
Connecting speakers .....	17
AUDIOHUB 2X4 SETUP EXAMPLES .....	18
1. Connecting several USB devices .....	18
2. Connecting a synth .....	19
3. Connecting Audiohub 2x4 to a DJ mixer .....	20
4. Using Audiohub 2x4 with an FX processor .....	21
APPENDIX .....	22
Performance Specifications .....	22
Troubleshooting .....	22

## INTRODUCTION

Thank you for purchasing this Novation Audiohub 2x4. The Audiohub 2x4 is a 2-in, 4-out audio interface combined with a 3-port USB hub. You can use it to connect Novation Launchpad and Launchkey products to your Mac or PC, get other analogue audio sources into your system and conveniently connect headphones and/or loudspeakers, either in your recording set-up or for live performance. If your system's based around an iPad®, you can use Audiohub 2x4 just the same with the addition of an Apple® Camera Connection Kit.

In common with all analogue audio products from the Focusrite family of companies, the Audiohub 2x4 provides the classic and renowned Focusrite 'sound', as designed by our dedicated team of audio engineers.

Whether you're a DJ or an electronic musician, you now have a simple and compact solution for interconnecting your music making equipment and routing high quality audio to and from your computer or iOS device.

This User Guide provides a detailed explanation of the hardware to help you achieve a thorough understanding of the product's operational features. We recommend that both users who are new to computer recording, as well as more experienced users, take the time to read through the User Guide so that you are fully aware of all the possibilities that the Audiohub 2x4 and accompanying software has to offer. If the main User Guide sections do not provide the information you need, be sure to consult <http://www.novationmusic.com/answerbase>, which contains a comprehensive collection of common technical support queries.

### Key Features

- USB interface for Mac, PC or iOS devices
- Three USB ports for connecting other USB-based equipment
- Two independent stereo audio outputs
- Balanced audio output (1 & 2) – connect to pro mixers, amplifiers, etc.
- Outputs 3 & 4 and duplicate of outputs 1 & 2 available on RCA connectors (unbalanced)
- LOUD(!) headphone output with independent level control
- Two Focusrite line inputs enabling additional audio sources to be connected
- Input Monitor feature for minimal latency while recording

### About This Manual

We've tried to make this manual as helpful as possible for all types of user, both newcomers to computer music and those more experienced, and this inevitably means some users will want to skip over certain parts of it, while a relative novice will want to avoid certain parts of it until they're confident they've mastered the basics.

However, there are a few general points that are useful to know about before you continue reading this manual. We've adopted some graphical conventions within the text, which we hope all types of user will find helpful in navigating through the information to find what they need to know quickly:

### **Abbreviations, conventions, etc.**

Where top panel controls or front/rear panel connectors are referred to, we've used a number thus: 6 to cross-reference to the diagrams. (See page 10.)

We've used **BOLD CAPS** to name physical things like top panel controls and rear panel connectors, and also on-screen buttons which you need to click, and **bold Courier font** to denote text which you see on the computer screen.

### **Tips**



These do what it says on the tin: we include bits of advice, relevant to the topic being discussed that should simplify setting up Audiohub 2x4 to do what you want. It's not mandatory that you follow them, but generally they should make life easier.

### **What's In The Box**

Audiohub 2x4 has been carefully packed in the factory and the packaging was designed to withstand rough handling. Should the unit appear to have been damaged in transit, do not discard any of the packing material and notify your music dealer.

Save all the packing materials for future use in case you ever need to ship the unit again.

Please check the list below against the contents of the packaging. If any items are missing or damaged, contact the Novation dealer or distributor where you purchased the unit.

- Audiohub 2x4 interface
- PSU (12 V DC, 1.5 A)
- "Getting Started" Guide
- USB Type A to B cable (1.5 m)
- Product/Software Registration Card, allowing download of:
  - Full User Guide
  - Ableton Live Lite (DAW)
  - 1GB of Loopmaster samples



## Registering Your Audiohub 2x4

It is important to register your Audiohub 2x4 at [www.novationmusic.com/register](http://www.novationmusic.com/register) using the Product/Software Registration Card. Apart from validating your manufacturer's warranty, you will also then be able to download the additional software that you are entitled to as an Audiohub 2x4 purchaser. The card also contains codes you will need to enter in the on-line forms on our website to download the software, but before you attempt to do this, warranty registration is required. This procedure ensures that you will have the most up-to-date software versions.

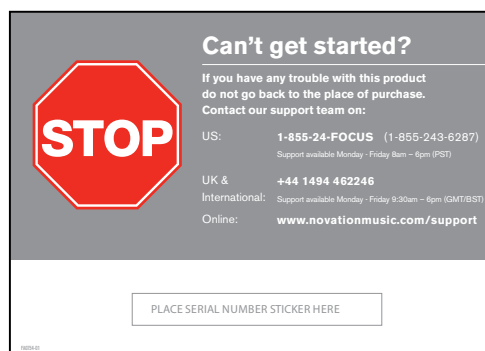
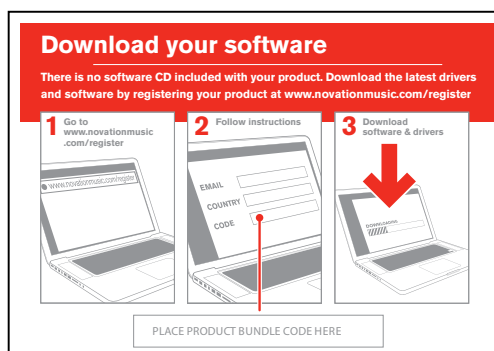

## Power Requirements

The supplied PSU (AC adaptor) **MUST** be used in the following situations:

1. If you want to use the Audiohub 2x4 to connect one or more other items of equipment via the Type A USB ports. The Audiohub-to-computer USB connection cannot supply power to external equipment.
2. If you are connecting the Audiohub 2x4 to an iPad (instead of a Mac or PC). The Audiohub 2x4 cannot be powered from an iPad.

The audio interface section can be powered from your Mac or PC via the USB connection, however it is strongly recommended that the PSU is used. Optimal audio streaming performance or high level headphone monitoring cannot be guaranteed when the PSU is not connected.

Furthermore, we recommend that you connect the Audiohub 2x4 directly to a computer's native USB port, and not via a further USB hub.





### A word about laptops:

When powering your Audiohub 2x4 from a computer you should be aware that although the USB specification agreed by the IT industry states that a USB port should be able to supply 0.5 A at 5 V, some computers - particularly laptops - are unable to supply this current. Unreliable operation may result in such a case. When using the Audiohub 2x4 from a laptop's USB port, it is recommended that the Audiohub is used with the power supply connected.

# HARDWARE OVERVIEW

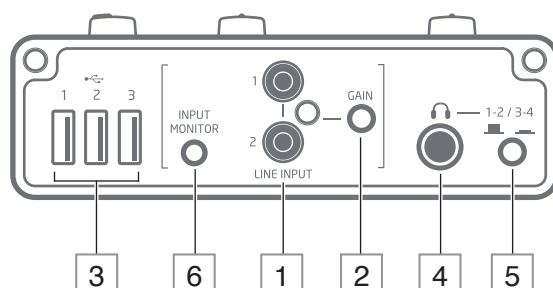

## Front Panel

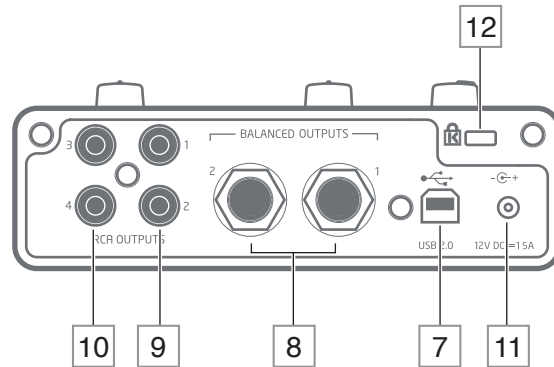

- 1 **LINE INPUTS 1 & 2** – phono input sockets for line level analogue audio signals. Signals connected here will be routed to the recording software on your computer or iOS device.
- 2 **GAIN LOW/HIGH** – push this button in to increase the gain of the line input stage by 10 dB. The LOW gain setting should be suitable for most consumer audio devices such as CD players; use the HIGH gain setting if connecting an iPad, iPhone or similar device, or a synth.
- 3  **1, 2 & 3** – three Type A USB 2.0 ports for the connection of external USB equipment.
- 4  – 1.4” (6.35 mm) 3-pole jack socket; plug your headphones in here.
- 5 **1-2/3-4** – this button selects which pair of outputs is routed to the headphone socket; output 1 or 3 is routed to the left, 2 or 4 to the right.
- 6 **INPUT MONITOR** – with this button pressed, audio at the line inputs [1] are routed directly to the Audiohub 2x4’s outputs. When using Input Monitor, be sure to disable input monitoring in your recording software, otherwise you will hear the source you are trying to record twice, the second time with a delay. See “Using Input Monitoring” on page 16.

## Rear Panel



- [7]  – Type B USB 2.0 port. Use this port to connect the Audiohub 2x4 to your computer or iOS device (via an Apple camera connection kit). The USB port is designed to provide a secure fit for the USB connector, thus making it harder to disconnect the USB cable accidentally.
- [8] **BALANCED OUTPUTS 1 & 2** – two ¼” (6.35 mm) 3-pole jack sockets. These outputs are electronically balanced; connect to professional external equipment such as power amplifiers, mixers, etc.
- [9] **RCA OUTPUTS 1 & 2** - two phono (RCA) sockets carrying the same signal as [8] above, but in unbalanced form at a lower level, suitable for connecting to the line inputs of hifi amplifiers, DJ mixers, etc.
- [10] **RCA OUTPUTS 3 & 4** – as [9], but carry the second pair of line outputs, 3 and 4.
- [11]  - DC input socket; connect the supplied AC adaptor here. See “Power Requirements” on page 9. Please note that **ONLY** the PSU supplied with the Audiohub 2x4 should be used; using other types may permanently damage the unit.
- [12] **Kensington security slot** – secure your Audiohub 2x4 to a suitable structure if desired. <http://www.kensington.com/kensington/us/us/s/1704/kensington-security-slot.aspx> provides further information on how to use this feature.

## Top Panel

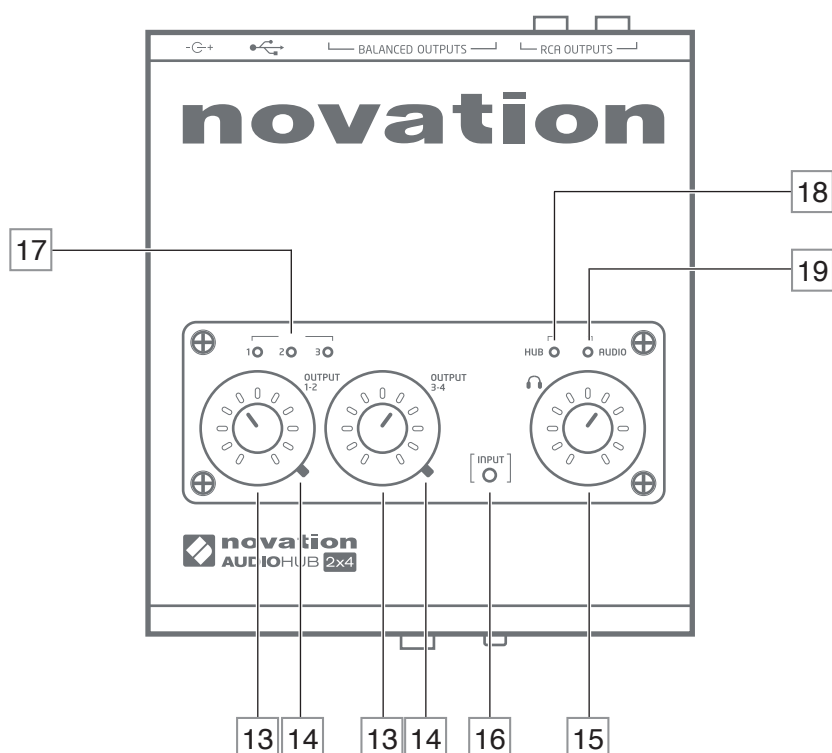

**13 OUTPUT 1-2 and OUTPUT 3-4** – two rotary controls adjusting the signal level at outputs 1 & 2 and 3 & 4 respectively. Note in the case of outputs 1 & 2, the level at both the balanced and unbalanced rear panel connectors is adjusted.

**14 Output level clip LEDs** – bicolour LEDs for each output indicating when output level is too high (green = OK, red = clip).

**15**  – adjusts the volume in your headphones (connected at the front panel headphone output) independently of the output level controls.

**16 Input level clip LED** – bicolour LED indicating when the signal level at the line inputs is too high (green = OK, red = clip).

**17**  **1, 2 & 3** – three green LEDs which illuminate to confirm connection on the relevant front panel USB port [3].

**18 HUB ACTIVE** – green LED; illuminates when the external power supply is connected.

**19 AUDIO ACTIVE** – green LED; illuminates to confirm that the audio interface section is active.

## Connecting Audiohub 2X4 To Your Computer

Your Audiohub 2x4 has been demonstrated to be compatible with the following operating systems:

### Mac OS:

Apple Macintosh with a USB 2.0-compliant USB port.

OS: OS X 10.9 Mavericks or Mac OS X 10.8 Mountain Lion (Class Compliant)

### Windows:

Windows-compatible computer with a USB 2.0-compliant USB port.

OS: Windows 8.1, Windows 8, Windows 7 (ASIO drivers can be downloaded via our registration page at [www.novationmusic.com/register](http://www.novationmusic.com/register).)

Use the supplied USB cable to connect the Type B USB port on the Audiohub 2x4 ([7] on page 11) to a spare USB port on your Mac or PC.

This will supply DC power to the audio interface section of the Audiohub 2x4, and allow you to use it as an audio interface. If you want to use the Audiohub 2x4 as a USB hub as well, you MUST connect the supplied external PSU.

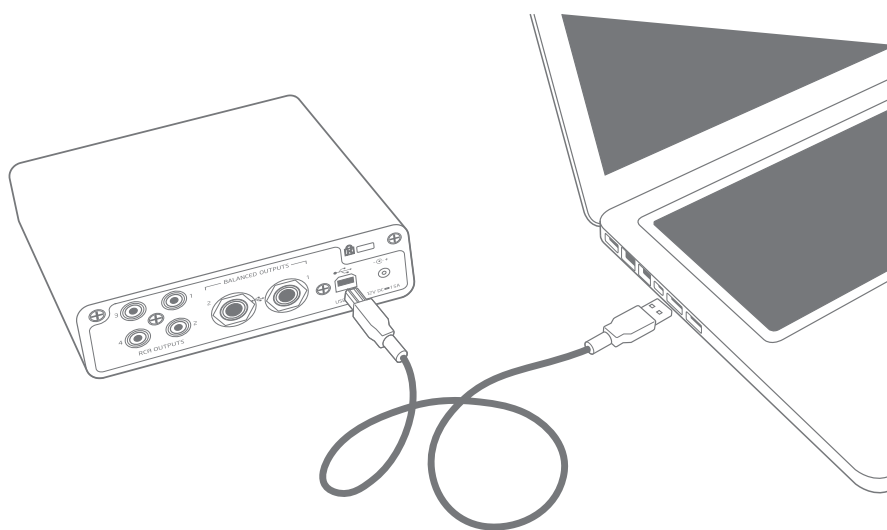

**Note:** We recommend that you ONLY connect to a computer's native USB port, and not to a separate USB hub of any kind.

**Mac OS only:**

Once initially configured, your OS should automatically switch the computer’s default audio input and output to be the USB port to which the Audiohub 2x4 is connected. To configure/ verify this, go to **Applications > Utilities > Audio MIDI Setup**. Right-click on Audiohub 2x4 and select ‘Use this device for sound output’. Then click on the Format box and select 44100.0 Hz.

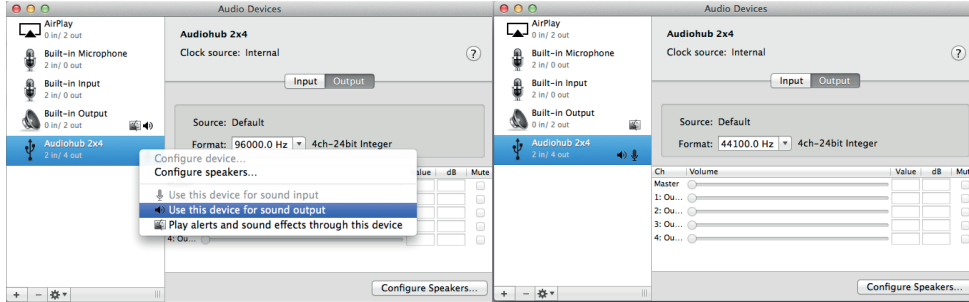

**Windows only:**

Computers will first require a Novation Audiohub 2x4 driver to be installed. This can be downloaded via our registration page at [www.novationmusic.com/register](http://www.novationmusic.com/register). Save and run in the normal way.

Check that the computer’s default audio input and output ports are set to be the USB port to which the Audiohub 2x4 is connected. To verify this go to: **Start > Control Panel > Sound** and ensure that the **Audiohub** is selected as the ‘Default Device’ on both the **Playback** and **Recording** tabs.

**Audio Setup in your DAW**

The Audiohub 2x4 is compatible with any Windows-based DAW that supports ASIO or WDM\* and any Mac-based DAW that uses Core Audio. After installing the drivers and connecting the hardware, you can start using the Audiohub 2x4 with the DAW of your choice.

To allow you to get started if you do not already have a DAW application installed on your computer, Ableton Live Lite is included in the free software package; this will be available to you once you’ve downloaded and activated your software on-line. To install Ableton Live Lite, download and save the Ableton installer file from your registered Novation “My Products” page as described above (you can also download the installer directly from the Ableton website at [www.ableton.com/live-lite](http://www.ableton.com/live-lite)). Note the software activation key which is made available once your Audiohub 2x4 has been registered, run the installer and follow all on-screen instructions.

Operating instructions for Ableton Live Lite are beyond the scope of this User Guide, but the application includes a full set of Help files.

\*only compatible with 16-bit audio under WDM

**Note:** your DAW may not automatically select the Audiohub 2x4 as its default I/O device. In this

case, you must manually select Audiohub as the default device on your DAW's Audio Setup\* page. Please refer to your DAW's documentation (or Help files) if you are unsure where to select the ASIO or Core Audio driver.

The example below shows the correct configuration in the Ableton Live Lite Preferences panel (Mac version shown):

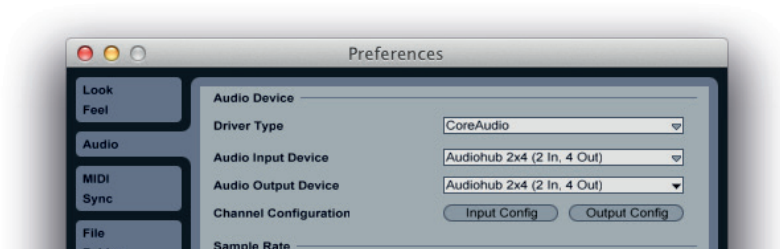

Once the Audiohub 2x4 is set as the preferred Audio Device\* in your DAW, its inputs (1 and 2), and outputs (1 to 4), will appear in your DAW's Audio I/O preferences. Depending on your DAW, you may need to enable certain inputs or outputs before use. The two examples below show Inputs 1 and 2 and Outputs 1 to 4 enabled in the Ableton Lite Audio Preferences.

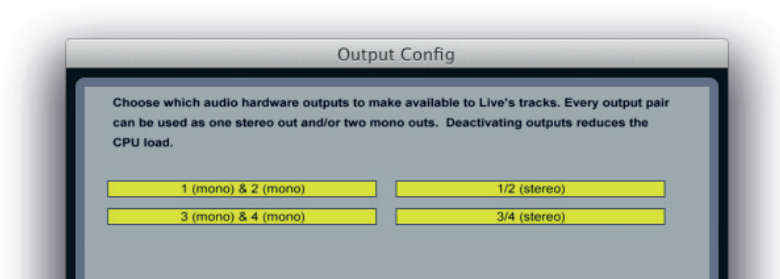
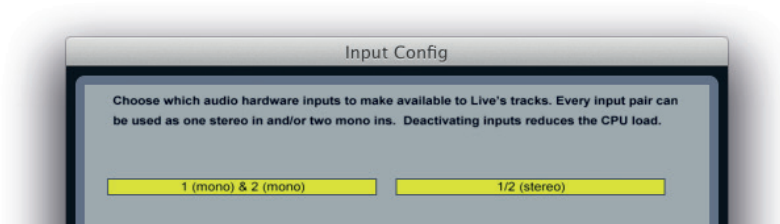

\*Typical name. Terminology may differ slightly between DAWs.

## Connecting Audiohub 2x4 to your iPad

If you are using your Audiohub 2x4 with an iPad, you will need an Apple iPad Camera Connection Kit (CCK) to connect them together. Plug the Camera Connector into your iPad's dock connector port, and use the USB cable supplied with the Audiohub 2x4 to connect it to the Audiohub.

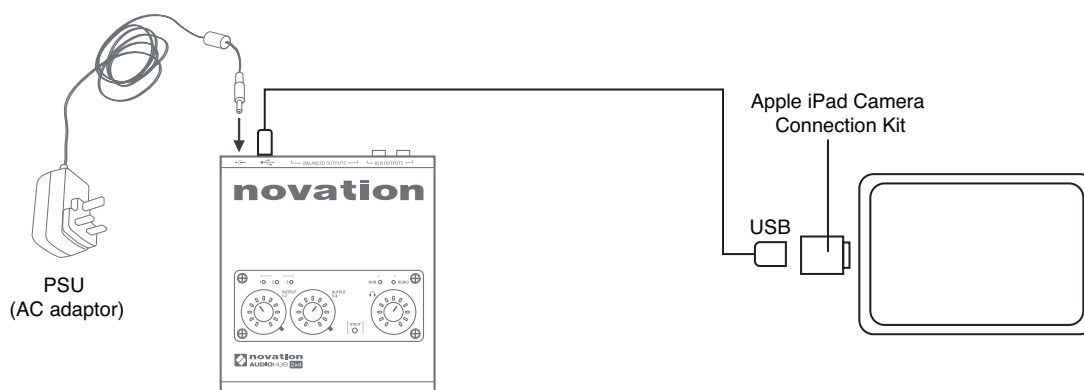

Note that you don't need the SD card reader that also comes with the CCK.

### IMPORTANT:

1. When using the Audiohub 2x4 with an iPad, the supplied PSU (AC adaptor) must be used to power the Audiohub. The Audiohub 2x4 cannot be powered from an iPad.
2. The iPad will not be charged by the Audiohub while they are connected.

Whichever recording app you're using, its input signals – the signals you're recording – will be derived from the Audiohub 2x4 once your iPad is connected. This is entirely automatic; unlike computer-based DAW applications, no set-up procedure is necessary. Similarly, the outputs of the app are immediately available at the Audiohub's outputs.

## Using Input Monitoring

You will frequently hear the term "latency" used in connection with digital audio systems. When you use a DAW or other software application to make a recording, latency is the time it takes for your input signals to pass through your computer and audio software, and back out again via your audio interface. Latency can be a problem for a performer who wishes to record while monitoring their input signals.

The Audiohub 2x4 is fitted with an "Input Monitoring" option, which overcomes this problem. Setting the front panel **INPUT MONITOR** control to **INPUT** will route your input signals directly to Audiohub 2x4's outputs 1 and 2. This enables you to hear yourself with minimal latency – i.e., in "real time" – along with the computer playback. The input signals to your computer are not affected in any way by this setting.



## Connecting speakers

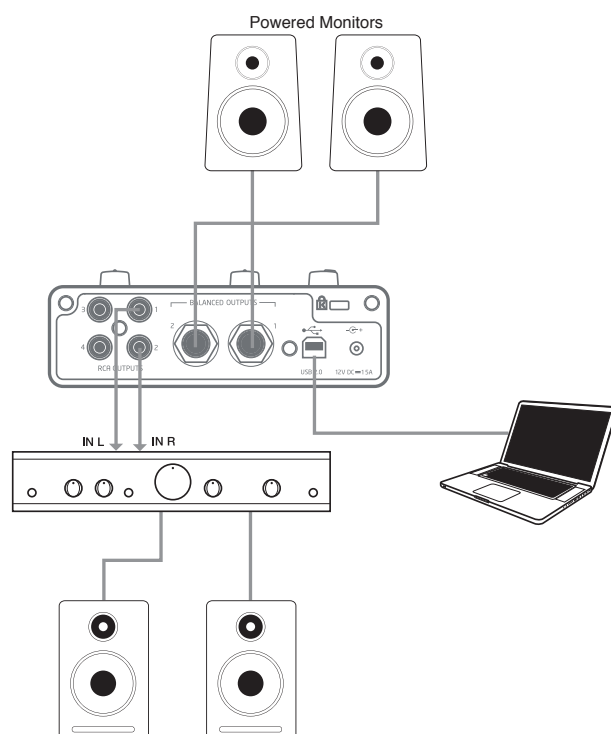

Self-powered monitors (i.e., typical computer speakers) incorporate internal amplifiers with a volume control, and may be connected directly to the Audiohub's outputs. Larger, passive loudspeakers will require a separate stereo amplifier; in this case, the outputs should be connected to the amplifier's inputs.

Typical consumer (hi-fi) amplifiers and small powered monitors will have unbalanced inputs, either on RCA sockets, or via a 3.5 mm 3-pole jack plug intended for direct connection to a computer. In either case, use a suitable connecting cable with phono plugs (RCA jacks) at one end. Hi-fi amplifiers and powered monitors will have their own volume controls; use these to adjust the monitoring volume.

Professional amplifiers will generally have balanced inputs (either on 3-pin XLR or 3-pole (TRS) ¼" (6.35 mm) jack sockets); use a suitable twin-and-screen cable to connect them to the ¼" jack outputs of the Audiohub 2x4.

### IMPORTANT:

The Audiohub 2x4 can be loud! Always turn all three volume controls on the Audiohub down to minimum before starting your session, and increase them as required once the sound is playing. Watch the signal level/clip LEDs, and make sure that the LEDs don't illuminate red. If the input LED shows red, turn the level of the source equipment down; if the output LEDs show red, turn the output of your music software down.



It is always good practice to leave the powered monitors (or power amplifier if using passive speakers) turned OFF until everything else is connected and working, and then turning them on last, gradually increasing the volume as necessary. The reverse also applies – turn the amplifier and/or speakers off FIRST, then disconnect the rest of your equipment.

## AUDIOHUB 2X4 SETUP EXAMPLES

Some typical applications are shown below.

### 1. Connecting several USB devices

The USB hub section of the Audiohub 2x4 can be used to connect up to three USB devices to your computer or iPad. This is of great advantage when using a laptop, as they often don't have enough native USB ports, and essential with an iPad, as the Apple CCK only provides a single port.

In the example below, three Novation controllers are shown connected to the Audiohub: a Launchpad S pad controller, Launch Control and a Launchkey Mini MIDI keyboard. The Audio hub is connected via an Apple CCK to an iPad; this would typically be running apps such as Novation's own Launchkey and Launchpad.

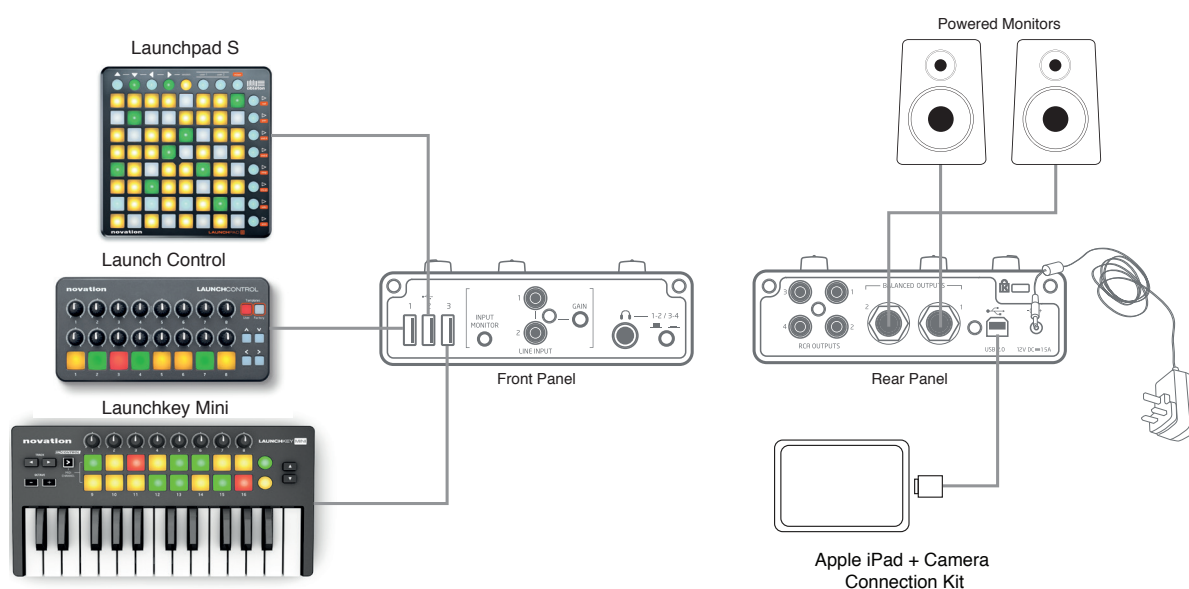

Note that the Audiohub 2x4's hub function is always available to link USB devices into your computer or iPad, regardless of how you use the audio I/O section. The three examples which follow demonstrate how you can also link analogue audio into your system.

## 2. Connecting a synth

You can use your Audiohub 2x4 as a means of adding live sound from a synth – or any other audio device - to the sounds coming off your computer or iPad.

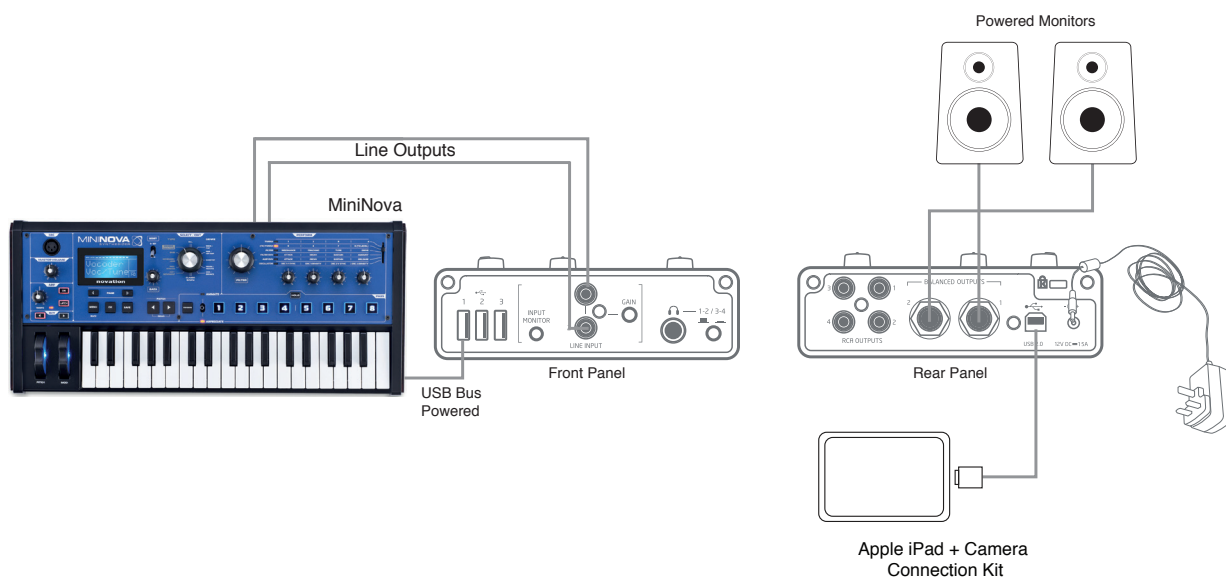

Connect the synth's audio output to the Audiohub 2x4's **LINE INPUT** phono (RCA) sockets. Connect either **BALANCED OUTPUTS 1 and 2** or **RCA OUTPUTS 1 and 2** to your powered monitor speakers (depending what type of inputs they have) with appropriate cables (see "Connecting speakers" on page 17).

Press the **INPUT MONITOR** button in; this will allow you to hear the synth's output directly, (see "Using Input Monitoring" on page 16), mixed in with the audio from your computer or iPad. The audio stream from your computer or iPad will be lowered in level slightly (approx. 5 dB) and the signals at the **LINE INPUT** connectors by approx. 8 dB, to prevent the addition of the "live" audio from the synth overloading either the Audiohub or the equipment connected to Outputs 1 and 2. The audio level at Outputs 3 and 4 is not affected.

**Note:** when connecting a mono synth (such as the Bass Station II) and making use of the input monitoring function, be aware that you will only hear it out of one speaker (which speaker depends on which input you connected it to). To hear the synth on both left and right speakers, use a special cable wired mono jack to two RCA plugs.

### 3. Connecting Audiohub 2x4 to a DJ mixer

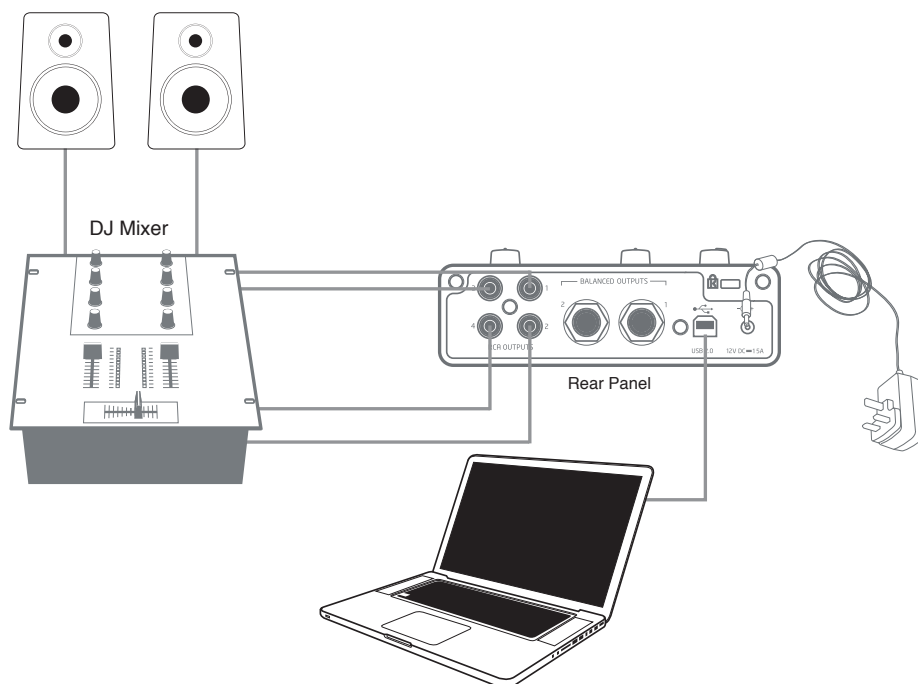

The Audiohub 2x4 can be used as an interface between a laptop running DJ software and the channels of a DJ mixer. In this setup, Outputs 1 and 2 can be connected to Line Inputs 1 and 2 of an external DJ mixer, and Outputs 3 and 4 to Line Inputs 3 and 4. Connecting in this way means that all mixer facilities, such as EQs and crossfading, are easily accessible.

In this application, the **INPUT MONITOR** button need not be pressed in.

#### 4. Using Audiohub 2x4 with an FX processor

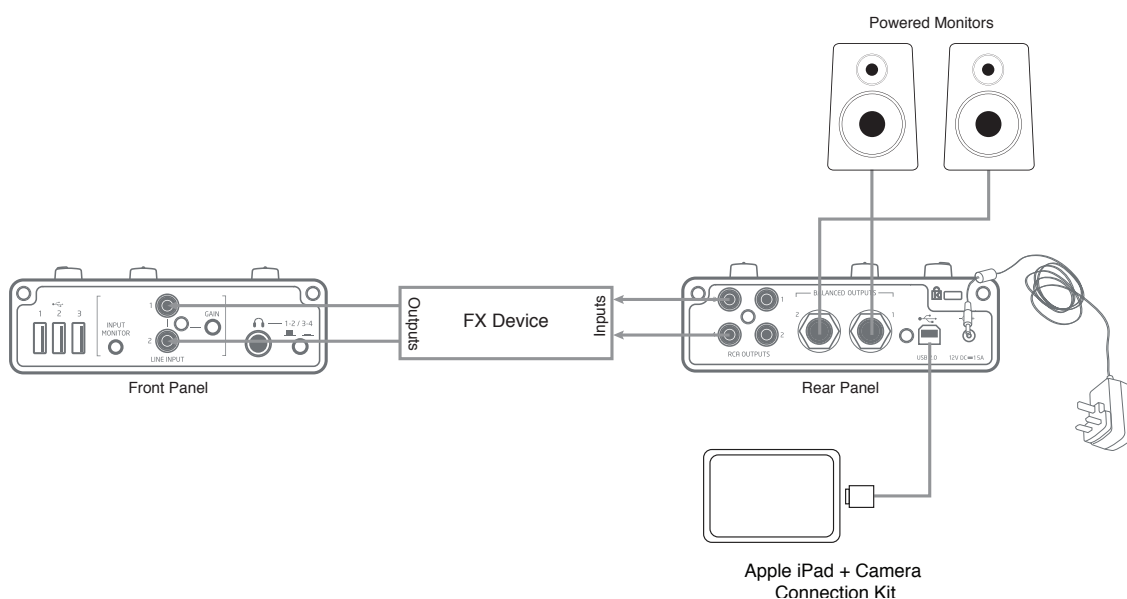

You can use Audiohub 2x4 to create a send/return loop to add an external FX processor into your system. Because the Audiohub 2x4 has two pairs of outputs, you can use **RCA OUTPUTS 3** and **4** to feed the inputs of the processor (output selection made from your DAW) while using **BALANCED OUTPUTS** (or **RCA OUTPUTS**) **1** and **2** for monitoring. The outputs of the processor are connected back to the Audiohub's **LINE INPUTS**.

The audio stream from your computer or iPad will be fed through the external processor and the outputs, plus effects, can then be mixed back into the overall output.

**Note:** When using the Audiohub 2x4 in this way, the **INPUT MONITOR** button should be pressed in.

# APPENDIX

## Performance Specifications

<b>Inputs</b>	
Gain	-0.7 dB or +9.1 dB
Input for full-scale amplitude low gain (0 dBFS)	+10.9 dBu
Alignment low gain (-18 dBFS)	-9.3 dBV
Alignment high gain (-18 dBFS)	-19.1 dBV
THD+N (-1 dBFS sine at 997 Hz, 20 kHz BW)	-97.6 dB, 0.0013%
Frequency response (20 Hz-20 kHz)	+0.03 dB, -0.29 dB
Dynamic range low gain	105.6 dB CCIR-RMS, 109.9 dB A-wgt
Dynamic range high gain	101.7 dB CCIR-RMS, 105.9 dB A-wgt
Input to input crosstalk	-84.5 dB (1 kHz), -96.5 dB (20 Hz)
Output to input leakage	-84.8 dB (1 kHz), -65.1 dB (20 Hz)
<b>Balanced Outputs</b>	
Max output	+18.4 dBu, +16.2 dBV
Max gain (above nominal -10 dBV output)	+8.2 dB
Volume range	69.4 dB
THD+N (-1 dBFS sine at 997 Hz, 20 kHz BW)	-99.7 dB, 0.001%
Frequency response (20 Hz-20 kHz)	+0 dB, -0.8 dB
Noise output	-88.9 dBu CCIR-RMS, -92.8 dBu A-wgt
Dynamic range	106.8 dB CCIR-RMS, 111.4 dB A-wgt
Output to output crosstalk	-101.8 dB (1 kHz), -101.5 dB (20 Hz)
Input to output leakage	-83.3 dB (1 kHz), -93.7 dB (20 Hz)
<b>Unbalanced Outputs</b>	
Max output	+14 dBu, +11.8 dBV
Max gain (above nominal -10 dBV output)	+3.8 dB
Volume range	69.3 dB
THD+N (-1 dBFS sine at 997 Hz, 20 kHz BW)	-90.6 dB, 0.003%
Frequency response (20 Hz-20 kHz)	+0 dB, -0.78 dB
Noise output	-90 dBu CCIR-RMS, -94.4 dBu A-wgt
Dynamic range	-104.3 dB CCIR-RMS, 108.4 dB A-wgt
Output to output crosstalk	-100.9 dB (1 kHz), -105.3 dB (20 Hz)
Input to output leakage	-89.9 dB (1 kHz), -99.8 dB (20 Hz)
<b>Headphones</b>	
Max power (0 dBFS, 100Ω)	73 mW
Rated power (<1%THD, 100Ω)	50 mW
Max output level (unloaded)	14.7 dBu

## **Troubleshooting**

For all troubleshooting queries, please visit the Novation Answerbase at [www.novationmusic.com/answerbase](http://www.novationmusic.com/answerbase) where you will find articles covering numerous troubleshooting examples.





