

● 50 mm T1.5 AS UMC Instruction Manual

We believe that this new 50 mm T1.5 AS UMC lens for video recording will give you a special photographic experience.

The 50 mm T1.5 AS UMC lens forms an optical system based on superior optical technologies, and maintains excellent resolution both at the center and around the periphery of the lens by adopting a high performance Glass Molding ASP lens and an UMC (Ultra Multi Coating).

Advantages of 50 mm T1.5 AS UMC

- 50 mm T1.5 AS UMC full frame image size.
- High-performance glass aspherical lens and Hybrid aspherical lens compensate the optical aberration optimally.
- It corrects optical aberrations by utilizing a complex aspherical lens, and produces a high resolution and high contrast at the center of the lens as well as at the periphery with a fully open aperture.
- The flower-shaped hood and UMC (Ultra Multi Coating) design suppresses flaring and ghost images.
- Robust durability with a high strength aluminum body.
- Smooth control when a follow focus is attached since the lens is equipped with a gear for the focus and aperture.

The 50 mm T1.5 AS UMC for video recording is designed with its own mount. You can mount the lens directly onto the camera without using an additional adaptor.
 ※ Please read this instruction manual carefully and use it accordingly.
 ※ Please read the 'Safety Precautions' at the back of this instruction manual prior to use.

● Please read this instruction manual prior to use. ●

○ Samsung NX Mount

- Record a video in A, M, or [icon] mode.
- Please note that while recording a video the shutter speed is limited to a minimum of 1/30.

(The procedures above are for the NX-200. The settings for the camera or the menu may vary based on the camera model or due to a functional upgrade. Refer to the camera manual or contact the camera manufacturer for detailed information.)

○ Four Thirds FT Mount

- Record a video in [icon], P, A, or M mode.
- Please note that while recording a video the shutter speed is limited to a minimum of 1/30.

(The procedures above are for the E-5. The settings for the camera or the menu may vary based on the camera model or due to a functional upgrade. Refer to the camera manual or contact the camera manufacturer for detailed information.)

○ Micro Four Thirds Mount

- Record a video in [icon], P, A, or M mode.
- Please note that while recording a video the shutter speed is limited to a minimum of 1/30.

(The procedures above are for the E-5. The settings for the camera or the menu may vary based on the camera model or due to a functional upgrade. Refer to the camera manual or contact the camera manufacturer for detailed information.)

1. Component Names

[Figure]

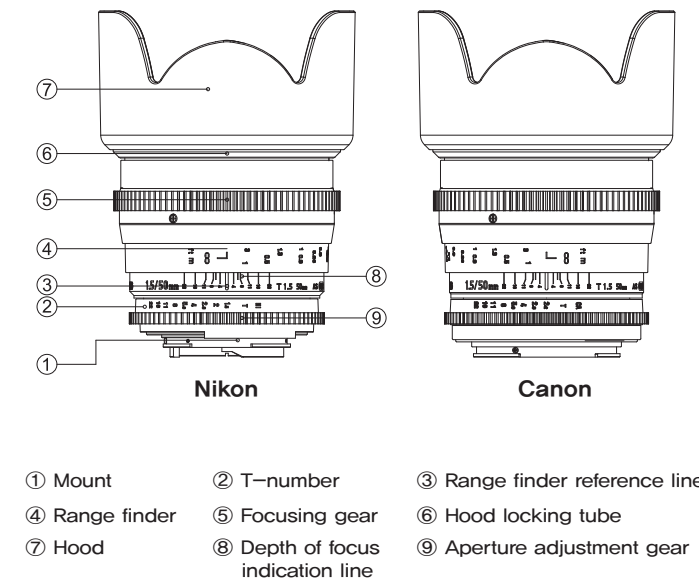

2. Attaching and Detaching

The 50mm T1.5 AS UMC lens mount is uniquely designed for Nikon (Fujifilm) F, Pentax (Samsung GX) K, Sony (Minolta), Canon EOS, Four-Thirds, and Samsung NX compatible cameras.

[Attaching]

Gently hold the lens hood, align the camera mount attachment point with the attachment reference point or line on the lens, push the lens into the camera and gently rotate the lens 90 degrees clockwise from the front view, until it makes a clicking sound.

[Detaching]

Gently hold the lens hood, press the lens release button on the camera, and turn the lens counterclockwise to detach the lens.

3. Focus Adjustment

When using the 50 mm T1.5 AS UMC lens, you can set the focus of a subject by turning the focus adjustment gear, since it is an MF (Manual Focus) adjustment lens.

[Nikon Mount]

- To change the focus from a subject that is far away to a subject that is close: Turn the focusing gear counterclockwise (from ∞ to 0.45) and focus on the clearest subject by using the indicator signal on the camera or by checking visually.
- To change the focus from a subject that is close to a subject that is far away: Turn the focusing gear clockwise (from 0.45 to ∞) and focus on the clearest subject using the indicator signal on the camera or by checking visually.

[Sony α / Sony E / Canon / Four Thirds / Samsung NX Mount]

- To change the focus from a subject that is far away to a subject that is close: Turn the focusing gear clockwise (from ∞ to 0.45) and focus on the clearest subject by checking visually.
- To change the focus from a subject that is close to a subject that is far away: Turn the focusing gear counterclockwise (from 0.45 to ∞) and focus on the clearest subject by checking visually.

4. Brightness Control

You can set the brightness you want by turning the aperture adjustment gear when using the 50 mm T1.5 AS UMC lens.

You can set T NO from 1.5 to 22. (The aperture is not positioned at any exact point, since it is adjustable continuously.)

5. Mounting the Hood

The hood has a bayonet system which guarantees speedy, efficient, safe and precise installation, and enables you to enjoy shooting that is free from ghosting or flaring.

[Figure]

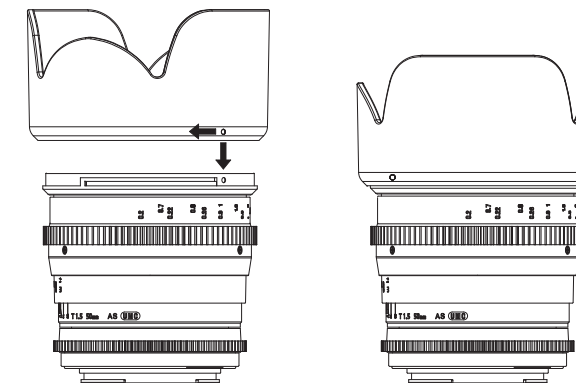

Align the attachment reference point on the hood with the reference point for a hood on the lens, push the hood onto the lens and turn the hood clockwise until it makes a clicking sound.

8. Troubleshooting

| Issue | Causes | Action |
|---|--|---|
| The lens cannot be attached to the camera. | The attachment reference point on the lens is not aligned with the lens attachment reference point on the camera. | Align the attachment reference point on the lens with the lens attachment reference point on the camera. |
| A lens cannot be detached from the camera. | Incorrect rotation direction for detaching the lens. If you turn the lens while holding the camera, it may cause damage to the lens. | Press the lens release button on the camera, and gently turn the lens to the lens attaching/detaching reference points, in the direction as marked on the camera, and then pull the lens forward. |
| Blurry images | Incorrect focusing/insufficient shutter speed or camera shake. | Turn the focusing ring while checking the subject using the indicator in the camera or checking visually to set the focus until the subject is clear and distinct, and then press the shutter. After selecting a shutter speed of 1/125 sec or faster, steady the camera and take a photograph. |
| Automatic focusing does not work properly. | This is a manual focusing lens and does not have an automatic function. | Turn the focusing gear to focus on a subject. |
| The pictures are too dark or too bright. | The exposure is incorrect. | Set the aperture adjustment gear of the lens correctly. |
| The camera flash is not synchronized to the camera. | The manual focusing lens may not be compatible depending on the camera. | See the camera manual. |
| There is no camera finder indication or display. | This lens does not have electronic contacts, so there is no electronic communication with the camera. | No problem with shooting. |
| Zoom failure. | This lens is a short focus lens. | |
| This lens cannot be mounted on other cameras. | This lens is designed for a specific mount type. | Purchase the designated lens mount. |
| You want to attach our ZX or 1.4X converter lens. | Our converter is designed for the T (M42 SCREW) mount only, thus it cannot be used with this product. | You can use each company's own mount converter. However, be aware that auto focusing will not be available. |

6. Camera Settings

Some cameras require special settings when using this lens.

○ Canon Mount

- Record a video in Av, Tv, P, CA, □ or M mode.
- Please note that while recording a video the shutter speed is limited to a minimum of 1/30.

(The procedures above are for the 5D MARK II. The settings for the camera or the menu may vary based on the camera model or due to a functional upgrade. Refer to the camera manual or contact the camera manufacturer for detailed information.)

○ Nikon Mount

Please refer to the following and set the camera when necessary.

- Record a video in M or A mode.
- Adjust the exposure using the dial steps +5 to -5.

(The procedures above are for the D7000. The settings for the camera or the menu may vary based on the camera model or due to a functional upgrade. Refer to the camera manual or contact the camera manufacturer for detailed information.)

○ Pentax K Mount

- Record a video in [icon] mode.
- Please note that while recording a video the shutter speed is limited to a minimum of 1/30.

(The procedures above are for the K-30. The settings for the camera or the menu may vary based on the camera model or due to a functional upgrade. Refer to the camera manual or contact the camera manufacturer for detailed information.)

○ Sony α Mount

- Record a video in A, S, P or M mode.

(The procedures above are for the A580. The settings for the camera or the menu may vary based on the camera model or due to a functional upgrade. Refer to the camera manual or contact the camera manufacturer for detailed information.)

○ Canon M Mount

- Record a video in Av, Tv, P, CA or M mode.
- Please note that while recording a video the shutter speed is limited to a minimum of 1/30.

(The procedures above are for the Canon M. The settings for the camera or the menu may vary based on the camera model or due to a functional upgrade. Refer to the camera manual or contact the camera manufacturer for detailed information.)

○ Fujifilm X Mount

- Record a video in [icon] mode.

(The procedures above are for the X-Pro1. The settings for the camera or the menu may vary based on the camera model or due to a functional upgrade. Refer to the camera manual or contact the camera manufacturer for detailed information.)

○ Sony E Mount

- Record a video in A, S, P or M mode.
- Adjust the exposure by rotating the dial at the back of the camera.

(The procedures above are for the NEX-5. The settings for the camera or the menu may vary based on the camera model or due to a functional upgrade. Refer to the camera manual or contact the camera manufacturer for detailed information.)

7. SPEC

| SPECIFICATIONS | | T1.5 50mm AS UMC | | | | | | | | | | | | |
|--------------------------------------|--|---|-----------|----------|--------|---------|------------|------------|---------|-------------|-------------------|-------|---|---|
| APERTURE RANGE (T-STOP) (Brightness) | | T1.5 to T22 | | | | | | | | | | | | |
| OPTICAL CONSTRUCTION | | 9 ELEMENTS IN 6 GROUPS (1 ASPHERICAL & 1 HYBRID LENS) | | | | | | | | | | | | |
| MINIMUM FOCUSING DISTANCE | | 0.45m (1.47 ft) | | | | | | | | | | | | |
| FILTER SIZE | | ∅ 77.0mm | | | | | | | | | | | | |
| MAXIMUM DIAMETER | | ∅ 81.6mm | | | | | | | | | | | | |
| MOUNT | | NICON | CANON EOS | PENTAX K | SONY α | CANON M | FUJIFILM X | SAMSUNG NX | SONY E | FOUR-THIRDS | MICRO FOUR-THIRDS | | | |
| ANGLE OF VIEW | | 35mm | 46.2° | 46.2° | 46.2° | 46.2° | - | - | - | - | - | - | - | |
| | | APS-C | 30.8° | 29.0° | 30.8° | 30.8° | 29.0° | 30.8° | 30.8° | 30.8° | - | - | - | - |
| | | FOUR-THIRD 4/3" | - | - | - | - | - | - | - | - | 23.6° | 23.6° | - | - |
| LENGTH (LENS MOUNT TO FRONT) | | 72.2mm | 74.7mm | 73.2mm | 74.2mm | 100.6mm | 101.0mm | 93.2mm | 100.7mm | 80.0mm | 99.5mm | | | |
| WEIGHT (CAP, HOOD DETACHABLE) | | 555g | 575g | 545g | 565g | 635g | 640g | 590g | 600g | 580g | 590g | | | |
| GEAR | | MODULE 0.8 | | | | | | | | | | | | |
| | | A 7 mm | | | | | | | | | | | | |
| | | B 4 mm | | | | | | | | | | | | |
| | | C 43.8 mm | | | | | | | | | | | | |
| | | D 8mm 10.5mm 9mm 10mm 36.4mm 36.8mm 29mm 36.5mm 15.8mm 35.3mm | | | | | | | | | | | | |
| FOCUS DIAMETER | | ∅ 81.6mm | | | | | | | | | | | | |
| APERTURE DIAMETER (∅70.4mm) | | ∅ 73.6mm | | | | | | | | | | | | |

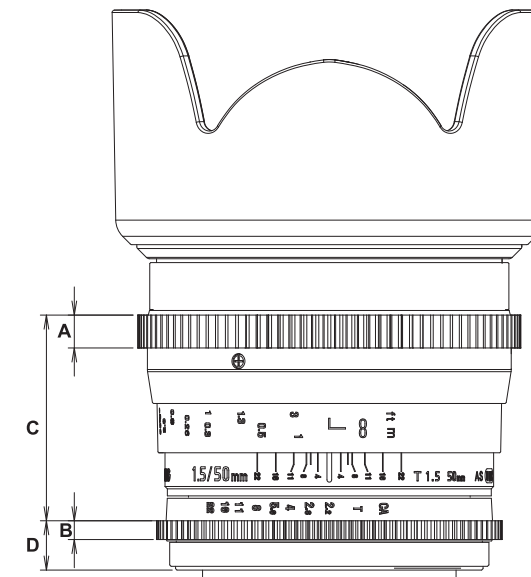

MEMO

The following precautions are divided into two types according to the level of danger:

Warning
 If this instruction is not followed, it may cause death or serious injury to the user.

Caution
 If this instruction is not followed, it may cause damage or injury to the user.

The following pictograms are used in the below precautions:

- Requires caution. Inside the pictogram it shows contents of precautions. (The pictogram on the left shows the caution for ignition.)
- Shows prohibition. Inside the pictogram it shows contents of prohibition. (The pictogram on the left shows the prohibition of disassembly.)
- Shows instruction. Inside the pictogram it shows contents of instructions. (It shows instruction of precaution in the pictogram on the left.)

Warning

- Don't look at the sun through the lens. It may cause blindness.
- Don't look at the sun through the lens. It may cause blindness.
- Don't look at the sun through the lens. It may cause blindness.
- Don't look at the sun through the lens. It may cause blindness.

Caution

- Match the lens to the camera correctly and make sure that the lens is attached firmly. If the lens is not attached correctly, it may not be pulled out or it may fall down, causing injury.
- Do not apply excessive weight on the lens attached to the camera. It may cause damage to the lens and camera mounts, or cause the lens to fall down, causing injury.
- Do not modify or alter the lens. Modified or altered lenses may not be repaired.
- Do not leave the lens in direct sunlight. It may cause a fire, depending on lenses that concentrate light on a close object.
- Do not look at the sun directly through a camera with a lens attached. It may cause damage to one's eyesight.
- Ensure that the camera operates properly by checking the lens before and after use. Shooting for important events such as a wedding ceremony and an overseas trip.

WARNING!
 Do not allow this product to get wet, or expose it to a moist environment. It may cause a fire or electric shock.

CAUTION!

- Don't use this product or store it close to devices that generate heat i.e., heaters, thermal regulators, stoves, stereo amplifiers.
- Do not expose the lens to drastic temperature changes.
- Do not touch the surface of the lens with your hand, or let it come into contact with sharp objects.
- Do not drop the lens.
- Do not soak the lens in water, and avoid water splashing onto the lens.
- If there are foreign bodies on the lens, use a lens cleaning kit only.