

ikan

3-axis Handheld Gimbal  
Stabilizer

# Beholder EC1

**Instruction Manual**

Encoders

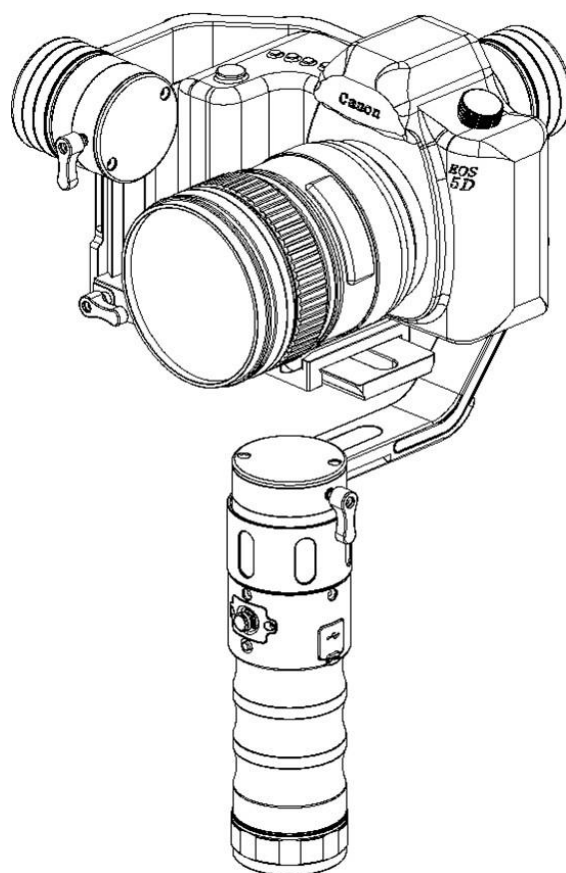

# Table of Contents

<b>Introduction</b>	
– About the EC1	3
– Features	4
<b>Product Description</b>	
– <u>What's Included</u>	5
– <u>Parts Diagram</u>	6
– <u>Charging the batteries</u>	7
– <u>Installing the battery holder</u>	8
– <u>Camera Installation and Balance</u>	9
<b>Getting to Know the EC1</b>	
– <u>Powering On</u>	14
– Modes of Operation (Profiles)	15
– <u>OLED Display</u>	16
– <u>Extensions</u>	16
<b>Compatible Camera Models</b>	
– <u>List of supported cameras</u>	17
<b>Camera Working Angles</b>	
– <u>Operable camera angles</u>	17
<b>Precautions and Safety</b>	
– <u>Precautions</u>	19
– <u>Safety</u>	20
<b>Copyright</b>	
– <u>Copyright/Trademark Statement</u>	21
<b>Product Specifications</b>	
– <u>Technical specifications</u>	22
<b>Frequently Asked Questions</b>	
– <u>FAQ</u>	23

## **WARNING**

To reduce fire or shock hazard, do not expose the unit to rain or moisture.

## **About the EC1**



### **Beholder EC1 – 3-Axis handheld gimbal stabilizer**

The Beholder EC1 is the newest upgrade to the popular gimbal Beholder DS1. It is designed specifically for professional filmmakers looking for a single handheld stabilizer for a large range of medium and small cameras. The EC1 makes it simple and easy to get outstanding stable footage.

Beholder EC1 is the first to use the 32bit motor encoder. It features adjustable curved arms and also adds an innovative pitch double adjustment that allows customers to use a large variety of camera sizes, from small mirrorless to large DSLR cameras.

Whether filming fast-paced actions or aiming for high or low-angle shots, this device will help you correct shakes or swaying and will balance and smooth the picture in order to achieve professional grade image stabilization.

Beholder EC1 is lightweight and easy to use and can be carried in the supplied case or a small photographer bag. EC1 can be widely used in movies, professional wedding films, and other applications. EC1 uses a 32-bit electronic board system that has several profiles for multiple shooting modes, which are easy to select by simply pressing a key. Beholder EC1 is shipped “**ready to use**” and does not require software changes in order to handle your camera. The encoder technology is built-in for faster system responsiveness, greatly improving the accuracy and stability at any angle, without having to switch modes manually.

EC1 allows the camera to rotate 360 degrees on all axes using slip-ring technology while removing rotation blockers used in previous versions to prevent wire twisting. It supports external remote control (wired or wireless), allowing you to extend the handle and mount directly onto a rocker arm to achieve high angle shots, boom moves, dolly shots, a smooth and seamless transition from high to low mode and also time-lapse photography. Beholder EC1 supports firmware upgrades for further software optimization.

EC1 has a standby time of 20 hours, while the built-in self-luminous OLED screen displays real-time power usage, allowing users to better understand the product’s electricity consumption in a timely manner in order to charge the battery. The OLED screen also displays the profile selected, allowing users to clearly understand the shooting mode currently in use.



## Beholder EC1 features

**Dimensions:** 360x184x79mm

**Compatibility:** Mirrorless & DSLR Cameras up to 5 lbs

### Main Features:

- 32-bit controller with motor control units (MCUs) and 12bit Encoder system
- OLED screen display for power and battery level
- OLED screen display for Profile Mode and joystick
- 3-axis gimbal stabilizer and 4-axis toolless design
- 3-axis 360° Pitch, Roll, Yaw (no limitation)
- Quick-release plate compatible with Manfrotto 577
- 4-way joystick to control the pitch and roll angle
- 3x 3.7v 18650 Detachable Rechargeable batteries
- Battery with an operation time of up to 20 hours
- One 3/8" screw hole in the handle bottom and one 1/4" hole on the side for mounting accessories like a monitor or microphone
- Increase the precision of stabilization by applying FOC-specific compensations
- Five pre-configured profiles including Lock, Pan-Follow, Follow, 3-Axis Follow, and Level Roll, Pitch to Horizon
- Prevents motors from losing synchronization and skipping steps
- Auto-Invert-Mode (all profiles can also be used in this condition)
- Bluetooth module for remote control (not included)
- 2.4g wireless joystick module for remote control (not included)
- Supported temperature accelerometer calibration
- Adaptive PID-algorithm for preventing vibrations in wide angles
- ACC low-pass filter to improve stability
- Provides information about frame angle and angle of the camera relative to the frame
- Five user-configurable modes of operation with a toggle button
- Option to adjust camera position with hands
- Low voltage protection for integrated battery
- Can significantly decrease power consumption by using field-oriented control strategy to drive motors
- Sound alerts for mode change and calibration
- Increases instant torque



**After you've received the product and before you use it, please check whether the package contains all the items in the following inventory. If any item is missing, please get in touch with the dealer to resolve the situation.**

EC1 body (Fig. A)

1. 3x 18650 batteries
2. Battery holder with USB charging port
3. 1/4 screw for camera quick release plate
4. Quick release plate compatible with Manfrotto 577
5. M4 screw long, mounted in pitch arm base
6. M4 screw short, mounted in pitch arm / motor
7. Battery compartment cap
8. M3 screw for quick release base locking
9. M4 screw short, mounted in yaw arm / motor
10. Yaw motor
11. M4 screw short, mounted in roll arm / motor
12. Roll motor
13. Pitch motor
14. Quick release locking base
15. 4-way joystick controller
16. OLED information screen
17. M3 screw for base balancing



In the box

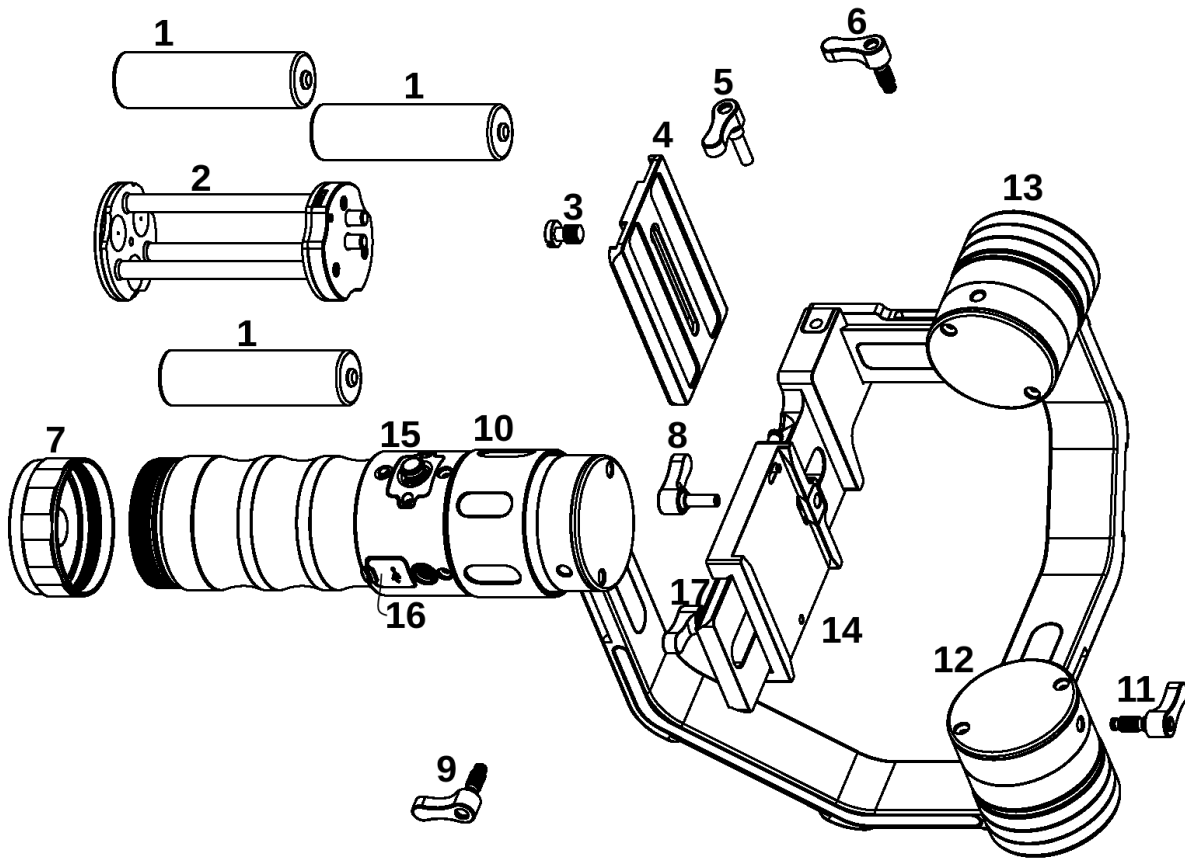

Fig A. Beholder EC1 parts



### Battery charging and inserting

For best performance, please use ikan IB-18650-26 batteries. The LED indicator will turn red while charging and green if the batteries are fully charged.

Connect the battery holder (Fig. 1) to the USB power supply before the batteries are installed in the holder. The LED will turn green to indicate the USB power can be used. Disconnect the battery holder and insert the three batteries. Connect the battery holder to the charger again. The LED indicator will turn red to indicate the batteries have started to charge. If less than three batteries are placed in the battery holder, the indicator light displays green to indicate that charging has not started. The battery holder can only charge all three batteries at once.

Note: The battery holder can only be used as a charger stand temporarily. When the battery LED indicator turns green to indicate the completion of charging, the batteries are only charged to 80% of the battery capacity. For 100% charge, please buy a professional charge adapter or use ikan's ICH-SC4 smart charger.

The battery holder charge time is 3-4 hours.

### WARNING

**When using the battery holder as a charger, the USB power supply must meet the minimum requirements.**

**The common USB port may not supply enough power to charge the batteries. A USB adapter rated at a minimum of 2.5A/12.5W or more may be needed.**

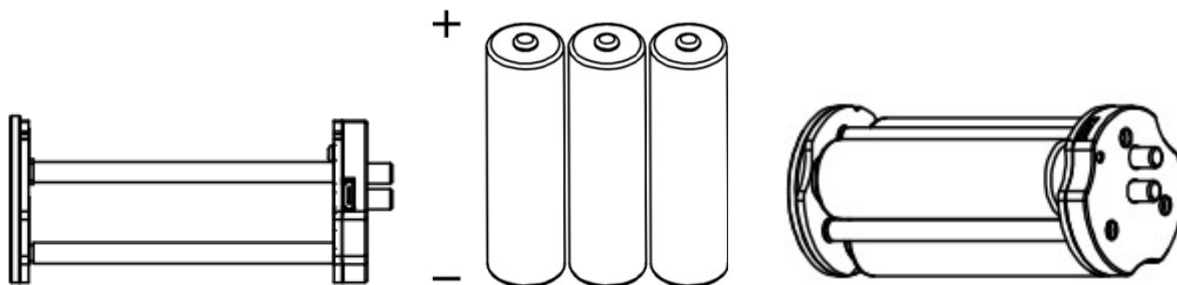

Fig. 1. Battery holder and 3x 18650 batteries

### Recommendations

- It is recommended to use a dedicated charger like the ikan ICH-SC4.
- If the product is not used for a long time, charge the batteries up to 70% of their capacity and store them in a cool, dry place.
- If you need more batteries, try to purchase ikan IB-18650-26-3PK official batteries or other reliable batteries with a protection circuit to avoid overcharging and damaging the batteries. Using damaged or different capacity batteries may result in failing to start up the Beholder EC1.
- Hint: Currently, the maximum capacity of an 18650 battery is 3500mah. Try to avoid fake suppliers advertising a huge capacity.

## Installing the battery holder



### Instructions to use the battery holder

Mount the 18650 batteries with the negative electrode of the battery (-) towards the spring (Fig. 2). Push the three 18650 batteries inward.

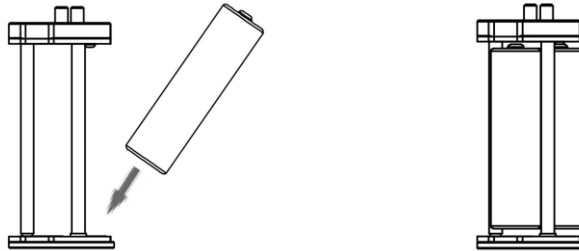

Fig. 2. Inserting batteries into the battery holder

Install the battery holder into the battery compartment with the two electrical terminals toward the direction of insertion (Fig. 3).

### **WARNING**

**Before starting the gimbal, make sure the camera is properly mounted on the stabilizer and perfectly balanced.**

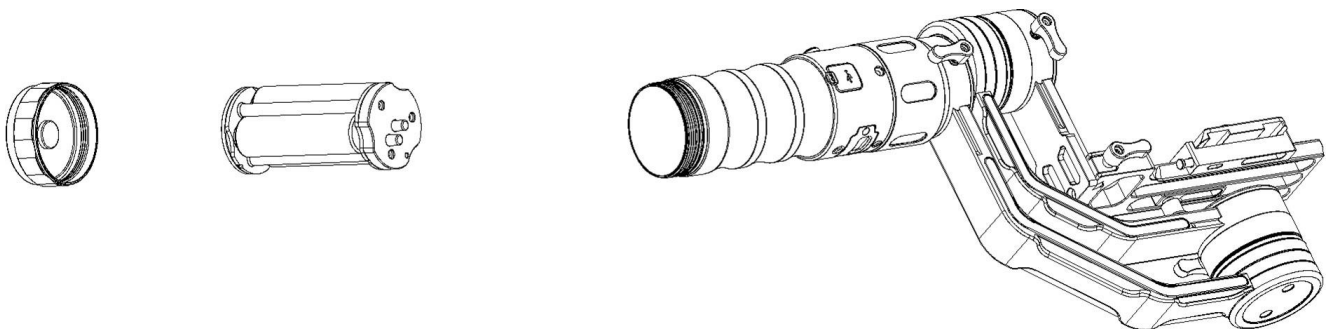

Fig. 3. Inserting the battery holder into gimbal handle





### Instructions to install the camera

#### **WARNING**

**Before installing the camera and adjusting the balance, remove the camera lens cover, attach the lens hood, and insert a memory card and camera batteries, as well as any other accessories. The camera should be fully ready to shoot.**

#### **STEP 1**

##### **Mount the camera quick release**

- Remove the quick release plate from the gimbal.
- Attach the quick release plate to the camera (Fig. 4). Be careful not to twist it too tight at this point.
- Make sure the quick release plate direction is facing forward toward the lens.

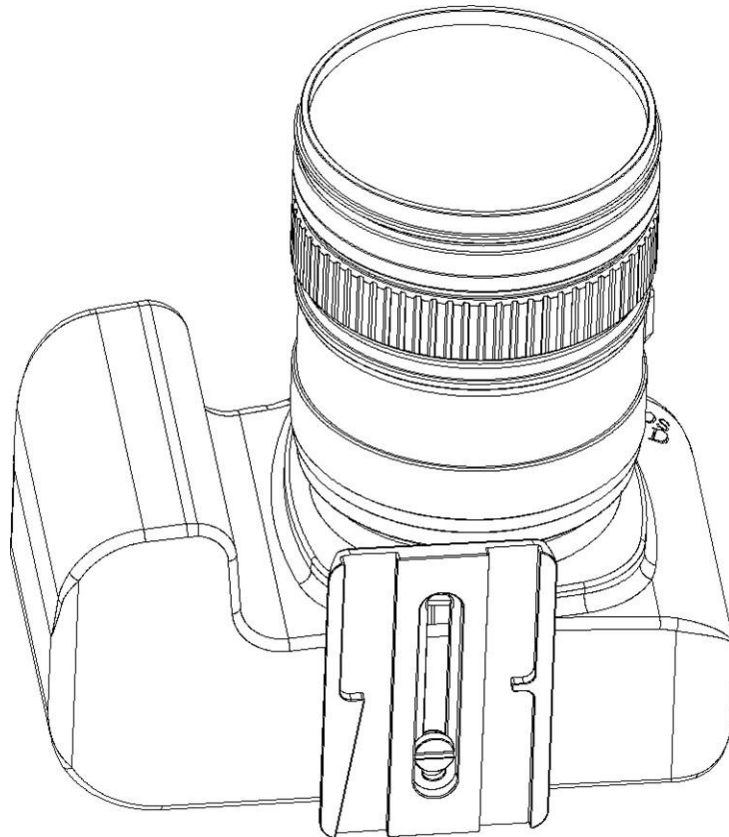

Fig. 4. The camera is attached to the quick release plate

## STEP 2

### Install the camera on gimbal base

- Install the camera with quick release mounted into the Beholder EC1 bottom mount base (Fig. 5).
- Slightly adjust the position of the camera into the base until you find a horizontal balance.
- Shift the camera as close to the pitch motor as possible. Use the base plate positioning if needed.
- Tighten the thumb screws.
- Use a screwdriver to tighten the 1/4 quick release screw.

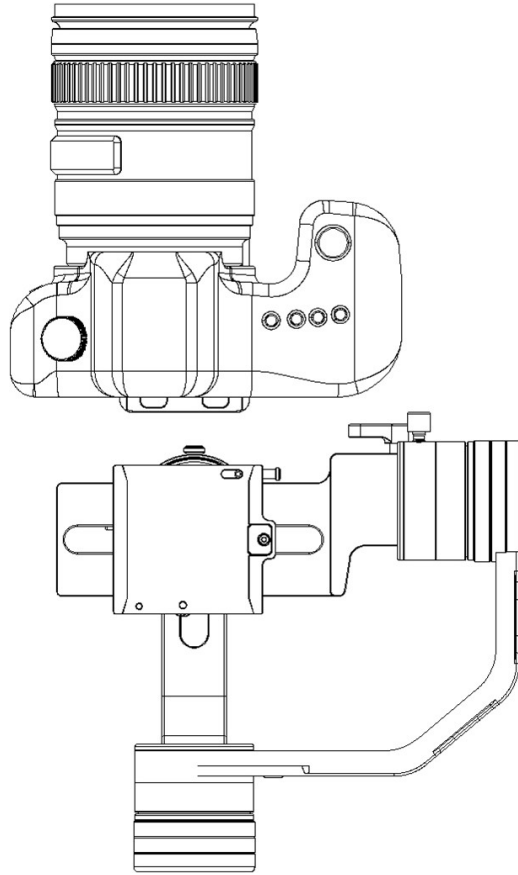

Fig. 5. Mounting the camera to gimbal base

### STEP 3

#### Adjust the gimbal roll – left and right balance

- Release the roll thumb screw (Fig. 6).
- Slide the roll arm left or right until the camera finds a balance position and doesn't lean left or right.
- In case more space is needed on either side, loosen the quick release base and slide the camera to the desired direction, fix the base in place, then readjust the roll arm.



Fig. 6. Roll balance adjustment

#### **STEP 4**

##### **Adjust the gimbal pitch - up and down balance**

- Release the pitch thumb screw (Fig. 7).
- Move the pitch/tilt arm up and down, until the camera stays in place at any lens angle.
- If needed, readjust the camera in quick release base back and forth until horizontal balance is found.
- Repeat up and down balancing to find perfect angular balance.
- Tighten the thumb screws.

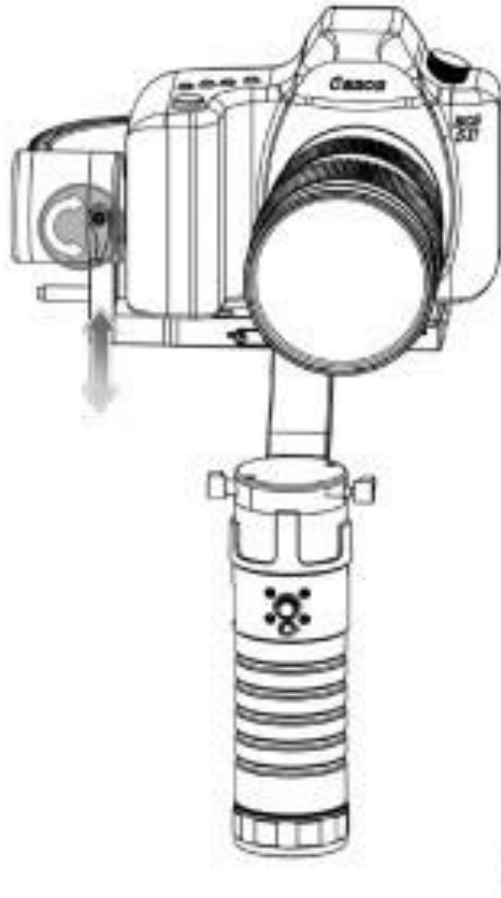

Fig. 7. Pitch balance adjustment

## STEP 5

### Adjust the gimbal yaw – forward and backward balance

- Loosen the yaw motor left thumb screw (Fig. 8).
- Tilt the gimbal handle 45 degrees forward.
- Move the yaw arm to the left side or to the right side at 90 degrees and observe the direction it tends to move when released.
- If the yaw arm tends to go up/backward, then the gimbal is front heavy: move the yaw arm back slightly and repeat the side test.
- If the yaw arm tends to move down/forward, it means the gimbal is back heavy: move the yaw arm slightly forward and repeat the side test.
- When in balance, the yaw arm should stay at any position around the handle when the handle is tilted forward.
- Tighten the thumb screws.



Fig. 8. Yaw balance adjustment

## Recommendations

- After adjusting the camera installation, check that each knob is fully tightened.
- Do not overtighten the screw wrench to avoid stripping the screw.
- For a very small camera and lens, if you cannot reach the balance as per above steps, then try to reposition the camera on the quick release in step 1. Repeat steps 1-5 otherwise a different camera/lens combo is required.

## TIP

Beholder EC1 uses the latest 32-bit systems, a multi-processor technology and inductive motor technology, with greatly improved torque. Therefore, it's able to start and level the camera if it is out of balance, but for shot stability, battery life and power saving, we strongly recommend you find the best balance first and then power the gimbal on and shoot the video.



## Starting the gimbal in default profile

- Press the power button for one solid second to power the gimbal on (Fig. 9 [2]).
- The gimbal will start in follow mode.
- Use the 4-way joystick (Fig. 9 [1]) to control the camera tilt and pan direction. Push the joystick up or down for tilting up and down. Push the joystick to the left or to the right to pan the camera left or right.

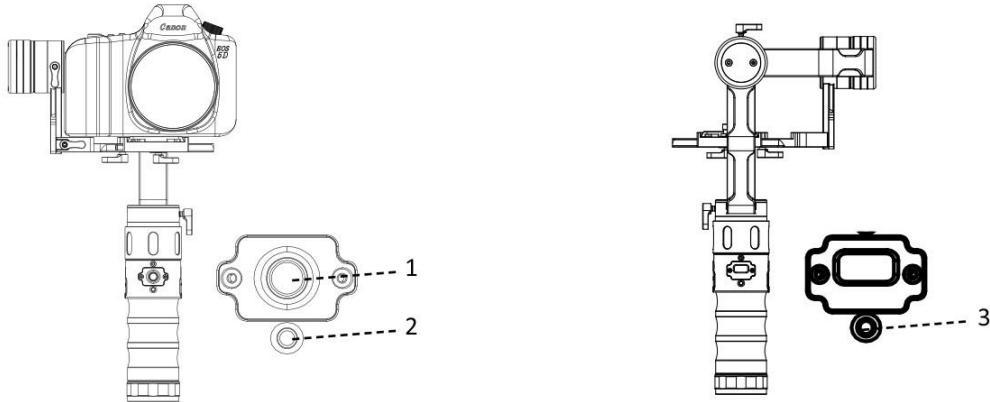

Fig. 9. Gimbal joystick

### TIP

**Make sure the batteries are fully charged before starting the gimbal.  
Adjust the gimbal and camera position before use. Beholder EC1 uses the latest 32-bit encoding technology and can start up in any direction and at any angle.**



### Switching the gimbal to different modes of operation (profiles)

- Press the mode button one time, which is located under the OLED screen (Fig. 9 [3]) to enter **Lock Mode (Profile 1)**: camera will hold the direction and not follow, pan, or tilt.
- Press the mode button twice to enter **Pan-Follow Mode (Profile 2)**: gimbal follows pan and holds the tilt position.
- Press the mode button three times to enter **Follow Mode (Profile 3)**: camera follows the tilt and pan directions.
- Press the mode button four times to enter **3-Axis Follow Mode (Profile 4)**.
- Press the mode button five times in a row to get to **Profile 5**: level roll and bring the pitch to the horizon.
- Press the mode button and hold for six seconds to calibrate the gyro.

#### TIP

Any of the profiles can be set to hold a specific angle or position manually. Take the camera with one hand and hold it in the desired position for 2 seconds. The system will automatically save the desired angle (Fig. 10).

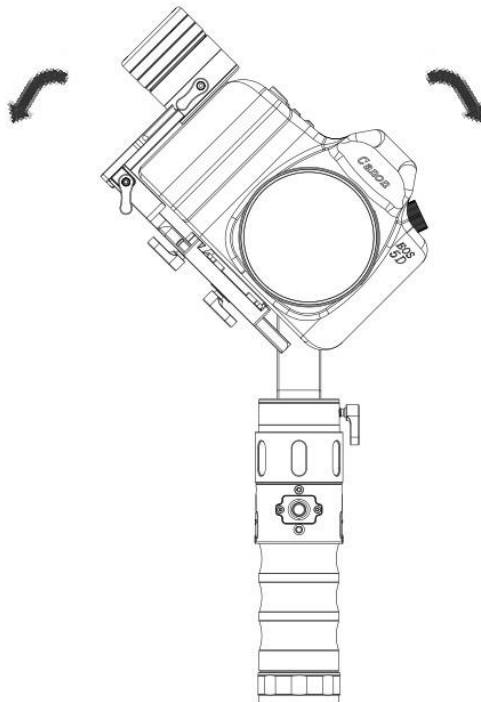

Fig. 10. Manual setting on the roll angle



## Description of OLED display functions



Boot up interface with company logo

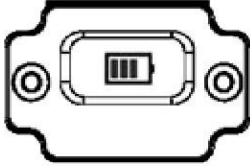

Charge:



85% to 100%



30% to 45%



65% to 85%



10% to 30%



45% to 65%



10% or less

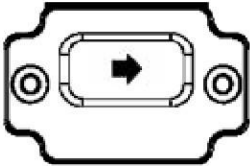

joystick right direction



joystick tilt up



joystick left direction



joystick tilt down

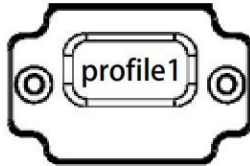

profile1: Press mode button once: Lock mode

profile2: Press mode button twice: Pan Follow mode

profile3: Press mode button three times: Follow mode

profile4: Press mode button four times: 3-Axis Follow mode

profile5: Press mode button five times: Level Roll, Pitch to Horizon

Note: Press and hold the mode button for 6 seconds to start gyro calibration

# Extra features



## Extensions and extra features

- 3/8 standard screw holes, connecting rods 1/4 or 3/8 turn screws sold separately.
- Mini USB for controlling the gimbal via wired joystick
- Handle screw for an external monitor and microphone, lights, etc.
- Genuine universal quick release plate Manfrotto 577 series, such as 501PL, 701, etc. 50mm width Quick Edition





## Compatible cameras



### Compatible camera models

- Beholder EC1 supports lighter than 2KG (including lenses) DSLR or mirrorless cameras
- List of supported cameras:
  - DSLR: Canon 6D / 5D / 7D
  - Mirrorless: A6300, A7R2, A7S + 24- 70 / 16- 35, GH4 + 12- 35, GH3 + 14- 140 and so on.
  - Compact cameras: RX100, LX100

## Gimbal working angles



### Handheld camera angle range

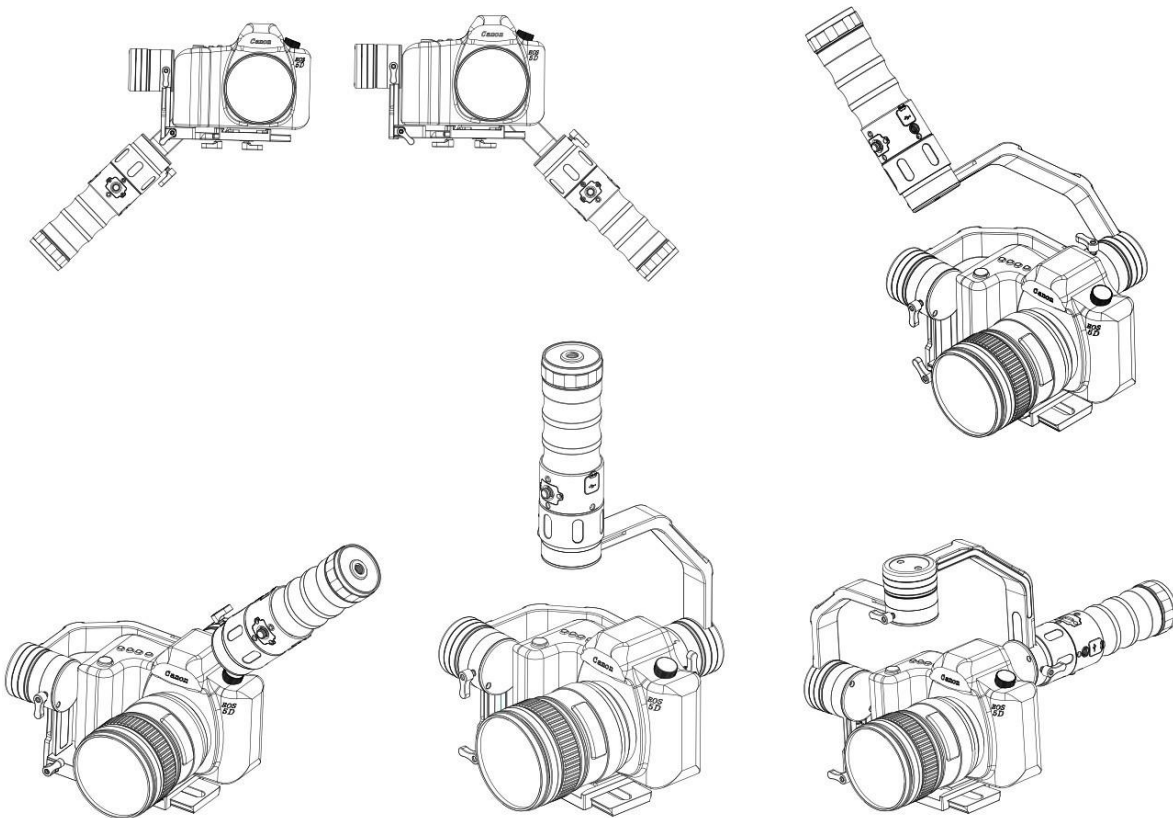

Fig. 11. Camera working angles



### Mounting options

Beholder EC1 supports two camera mounting options: Roll arm to the left or roll arm to the right of the center (Fig. 12). The right side is useful if your camera has a flip screen.

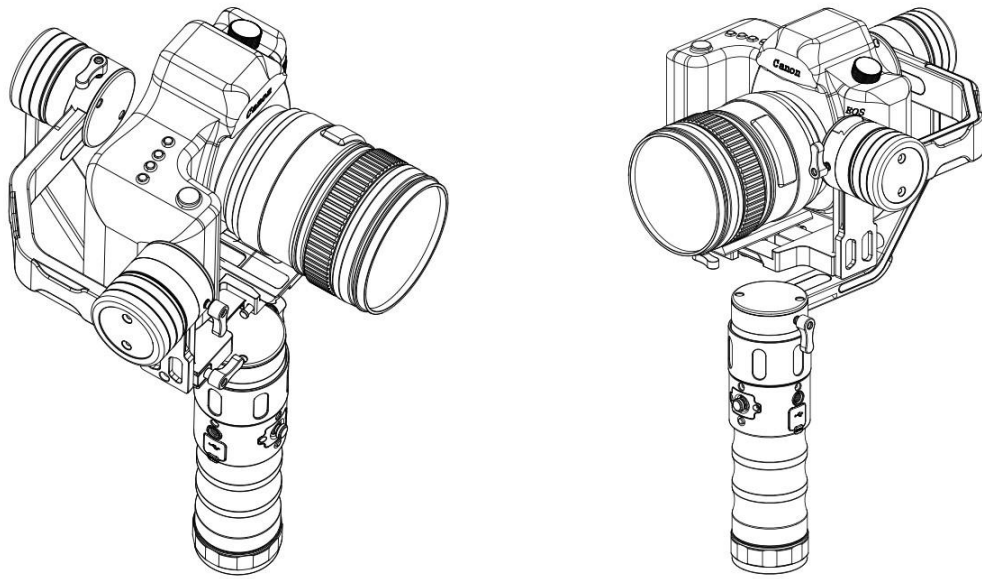

Fig. 12 Camera mount – left side or right side roll arm



### Things to consider before use

Beholder EC1 is shipped from the factory with perfect calibration. However, after a long period of unuse or if the temperature difference is too large, it may cause the gyro to drift automatically or to tilt during use.

**Gyro Correction:** Place the Beholder EC1 horizontally on the table, power on the gimbal and press and hold the menu button for 6 seconds. The system automatically enters the gyroscope calibration mode. The motors lose power for 5 seconds. After that, the automatic system calibration is complete and the stabilizer can resume normal use.

### Note:

1. During the calibration process, hold the gimbal handle on the table as stable as possible.
2. The mini USB port is designed only for a wired joystick and can't be used for charging.
3. In order to obtain a better shooting experience in the use of EC1 when shooting, avoid any collision and do not use excessive force.



## Important safety instructions

1. Do not get too close to a magnetic field or a source of extreme heat and fire.
2. Using and storing this product under high temperature and humidity, water, or in a highly corrosive environment can cause the device to have internal failure.
3. Protect the power cord to avoid trampling or backlog, particularly at plugs, sockets and other parts.
4. Do not use an incompatible power supply, charger or batteries that may cause a fire, explosion or other hazard. Use only manufacturer-approved equipment and matching accessories to meet safety standards. Other types of accessories may cause problems with the product, or a safety incident.
5. When not using the product for a long period of time, please remove the battery, wrap it in dust-proof packaging and place it in a dry environment.
6. Do not use the device during a thunderstorm or it may result in equipment malfunction or risks being struck by lightning.
7. Do not expose the battery to excessive heat in the environment, such as sunlight, fire or similar factors.
8. Do not expose this appliance to dripping or splashing liquids.
9. Do not place conductive objects at the battery holder electrical terminal, or in contact with the battery ends, in order to avoid short-circuiting the battery or getting burns and other physical injuries due to the battery overheating.
10. Do not expose the battery near any heat sources such as sunlight, heaters, microwave, oven, stove, radiator, or other instruments that produce heat (including amplifiers).
11. If the battery is used improperly, there may be an explosion hazard. In order to reduce the risk of fire or burns, do not disassemble, crush, puncture, short external connections, expose to heat or throw in fire.
12. If the batteries leak, do not allow the liquid to come in contact with the skin or eyes. If the liquid does come in contact with the skin or eyes, wash affected area with water immediately and go to the hospital for medical treatment.
13. If battery discoloration, deformation, abnormal heat, or other phenomena occurs, please stop using and replace the battery.
14. **WARNING: CHOKING HAZARD** - This product may contain small equipment and parts. Keep the device and its accessories out of reach of children as they may damage the device or swallow small parts.
15. Dispose of used batteries in accordance with local regulations.



### Copyright/Trademark statement

Beholder® and ikan® are certified trademarks, which cannot be used without our permission for any other purposes. The product has a number of patents so if copies of the product are found, the perpetrator will hold the relevant legal responsibility.

A regular dealer must obtain marketing authorization documents. Please visit an authorized dealer to purchase.

A list of distributors can be found on the website. In case the product is purchased on a non-authorized channel, we will not provide after-sales service for the product.

Product features, appearance or other functions may change over time. The company is free to implement and release any changes as desired.

### Learn More:

More dynamic information at official website: [www.ikancorp.com](http://www.ikancorp.com)

### Support:

Contact email: [support@ikancorp.com](mailto:support@ikancorp.com)



## Beholder EC1 technical specification

Model:	EC1 3-axis single handheld gimbal stabilizer
Load Capacity	2000 g
Battery	3x 18650 3.7v
Battery Operating Time	Approx. 8-10 hours
Battery Charging time	Approx. 3-4 hours
Working temperature:	-10 to 70 degrees Celsius
Working angles: (360° no limit)	Yaw: 360 ° Roll: 360 ° Pitch: 360 °
Tripod Mounting Thread	3/8"
Accessory Mounting Threads	1 x 1/4"
Dimensions	Length 360 mm Width 184 mm Height 79 mm
Weight	2.6 lb (1.2 kg)
Camera Support:	Canon: 5D / 6D / 7D + 16-35 f4.0 / f2.8, 24-105 f4.0, 24-70 Mirrorless, bridge and compact cameras: A6300, A7 Series + 24-70 / 16-35, GH4 + 12-35 / 14-40 / 7-14, RX100, LX100



### Frequently asked questions and answers

#### 1. How do you charge the gimbal?

*Beholder EC1 can be charged in two ways: using the built-in battery holder micro USB or using a separate authorized dedicated charger (recommended) such as the ikan ICH-SC4.*

*Charging using the battery holder:*

- Remove the battery cap cover on the bottom of the handle.*
- Take the battery holder out.*
- Connect the power cable to the Micro USB.*
- Connect the other cable end to power supply.*

*Charging using a dedicated charger:*

- Buy an authorized smart charger.*
- Release the battery holder.*
- Take out the batteries and charge with fastcharger.*

#### **TIP**

**Fully charged 18650 batteries measure 4.21V through a volt meter.**

#### 2. After mounting the quick release plate, sliding it into the stabilizer seems difficult. How do you fix this?

*Release the 1/4 screw about two turns and then insert to the gimbal QR base.*

#### **TIP**

**After balancing the camera, mark the position with a pen. This will help you find the balance faster the next time you mount the same camera and lens.**

#### 3. After balancing the camera, adjusting the camera's center of gravity, and tightening the screws, the camera is still wobbly and unstable. Why?

*You need to put the rubber stickers onto the quick release plate and then put the camera back on.*

#### 4. Why is my battery holder not charging?

*When using the battery holder as a charger, the USB power supply must meet the minimum requirements. The common USB port may not supply enough power to charge the batteries. A USB adapter rated at a minimum of 2.5A/12.5W or more may be needed. You can also purchase the Beholder multi-function intelligent charger.*

**5. When I start up the stabilizer (the camera's center of gravity has been adjusted), why is it always twisted to one side?**

*This may be from gyro magnetic fields that are affecting the surrounding environment, leading to an incorrect gyro direction. Solution: Press and hold the mode button for about 6 seconds to enter the calibration mode. It can be used normally after calibration is complete.*