



#### SYSTEM COMPONENTS

**Enclosure:**

3/4" 7-ply poplar plywood

**Low Frequency Transducers:**

2 - 12" INFRA cone  
2.5" Voice coil  
80 oz. Magnet

**Input Connectors:**

2 - Dual banana  
2 - Neutrik Speakon

**Grille:**

16 Gauge black vinyl coated perforated steel

**Standard Hardware:**

2 - Recessed handles  
1 - 35 mm Pole mount adapter  
8 - Interlocking corners

#### ACOUSTIC AND ELECTRICAL

**System Type:**

Infrasub sealed chamber  
(2.9 ft<sup>3</sup>)

**Impedance:**

4 Ω

**Crossover Network:**

Requires INFRA Integrator

**Frequency Response:**

8 Hz to 95 Hz ±3 dB  
(2π Steradians, with  
8 Hertz Integrator)

**Sensitivity:**

95 dB SPL @ 80 Hz (1W @ 1m)  
(for additional information,  
see INFRA Speaker Sensitivity  
Technical Note)

**Power Handling:**

400 W continuous sine wave  
400 W instantaneous peak

#### PHYSICAL

**Finish:**

Black carpet

**Dimensions:**

28.5"h x 18.5"w x 15.5"d  
73 cm x 49 cm x 40 cm

**Weight:**

74 lbs.  
34 kg

**Shipping Dimensions:**

18" x 30" x 21"  
46 cm x 77 cm x 54 cm

**Shipping Weight:**

81 lbs.  
37 kg

#### APPLICATIONS:

**Musical Instrument Systems**

**Discotheque Subwoofer**

**Auditorium Reinforcement**

**PA Systems**

**D12E-C** The D12E-C is a high output INFRA subwoofer system designed to provide high fidelity extended low frequency audio reproduction from a relatively small enclosure. The D12E-C provides perfectly flat response down to 8 Hertz when used in conjunction with the 8 Hertz Integrator. Designed for portable use, the D12E-C includes handles, protective corners and a pole mount adapter on a carpeted enclosure.

**ABOUT INFRASUB TECHNOLOGY** Almost all specifications for subwoofer systems are fixated on the frequency response domain. However, the impression of power and quality is equally related to the time domain performance of a system. Because of the long wavelengths of low frequencies, this is particularly true with subwoofers.

Likewise, the maximum SPL is not a very reliable way to judge the impact of a subwoofer. A poor time domain performer will not have the same impact or natural sound as a time correct INFRA system.

The reason that INFRA technology sounds dramatically better than the others is because of their superior time domain performance. The INFRA subwoofer maintains the bass energy in a tight packet, aligned with the upper range signal, providing a greater body impact and a seamless musical connection with the main loudspeakers.

Conventional sub designs perform so poorly in the time domain because designers have used methods that sacrifice the phase response for more control over the frequency response (e.g., steep low pass filter slopes, vented speaker enclosures, and narrow bandwidth systems). With the INFRA technique, we do not degrade the phase response while extending the frequency response.

While the INFRA dual integrator does function as the system crossover, it does so without using a low pass filter. Adding a low pass filter, analog or digital, will have a degrading effect on the time domain performance of the INFRA subwoofer. A low pass filter adds signal delay to the sound which varies with frequency. Also, narrowing the pass band increases the influence of the rolloff on both ends of the subwoofer spectrum. The result is the smearing of the arrival times of the low frequency sound components, changing the timbre and downgrading the impact of transient sounds.

The Bag End INFRA subwoofers are designed as no-compromise, high fidelity reproduction systems. We believe they are the finest subs available, regardless of price.

**BAG END Loudspeakers**  
22272 Pepper Road  
Barrington, Illinois  
60010 USA  
Voice 847 382 4550  
Fax 847 382 4551  
www.bagend.com





# D12E-C

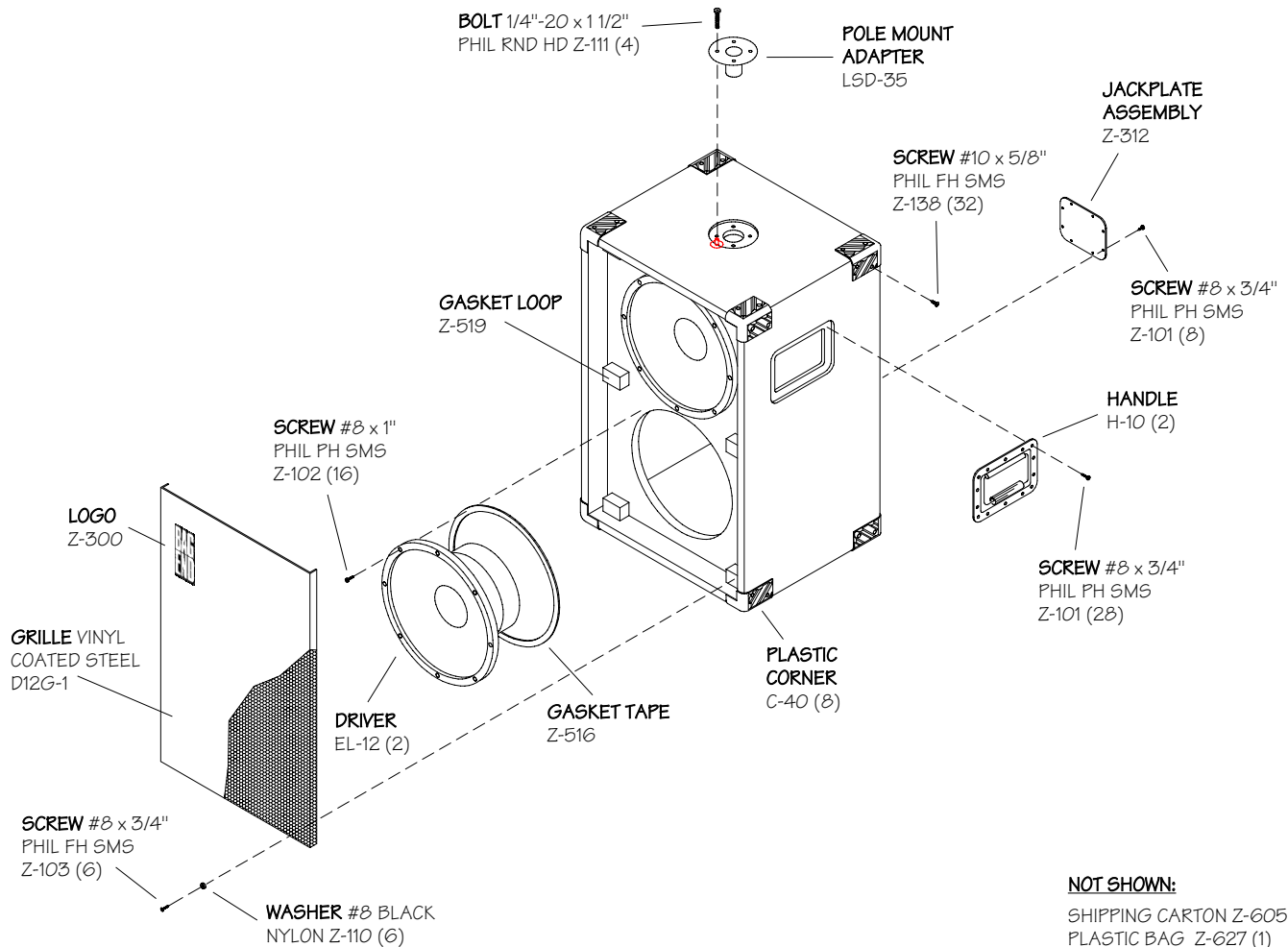

## SYSTEM SCHEMATIC

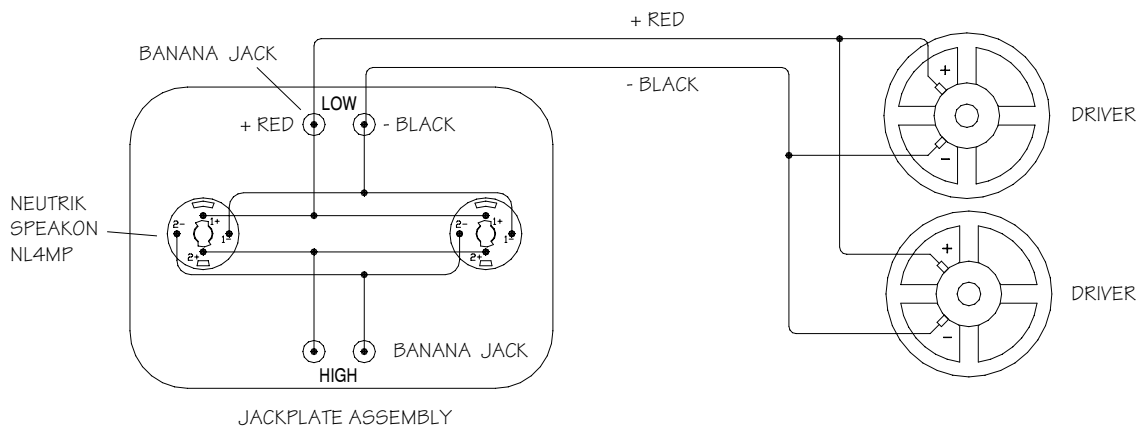

The Neutrik Speakon NL4MP connector is a keyed, high current, four conductor device which allows both the high and low frequency signals for a bi-amped loudspeaker system to run through the same multi-conductor cable. Note that all four conductors on both connectors are wired in parallel, but only two conductors are connected to the drivers in the enclosure. This permits an easy parallel connection to other similar loudspeakers (if your amplifier can handle the low impedance load!) and allows the use of a short "jumper" to connect to the mid/high speakers in a bi-amped system. Banana jacks are also provided on each circuit.