



SYSTEM COMPONENTS

Enclosure:

18 mm 13-ply birch plywood

Low Frequency Transducer:

18" INFRA cone
3" Voice coil
120 oz. Magnet

Input Connectors:

Cinch 142 screw terminal
barrier strip

Grille:

16 Gauge black vinyl coated
perforated steel

Standard Hardware:

4 - Machined aluminum speaker
mounting clamps

Optional Hardware:

Rigging points

ACOUSTIC AND ELECTRICAL

System Type:

Infrasub sealed chamber (3 ft³)

Impedance:

8 Ω

Crossover Network:

Requires INFRA Integrator

Frequency Response:

8 Hz to 95 Hz ±3 dB
(2π Steradians, with
8 Hertz Integrator)

Sensitivity:

96 dB SPL @ 80 Hz (1W @ 1m)
(for additional information,
see INFRA Speaker Sensitivity
Technical Note)

Power Handling:

400 W continuous sine wave
400 W instantaneous peak

PHYSICAL

Finish:

Black paint

Dimensions:

21" h x 22" w x 18" d
54 cm x 56 cm x 46 cm

Weight:

64 lbs.
29 kg

Shipping Dimensions:

24" x 25" x 21"
61 cm x 64 cm x 54 cm

Shipping Weight:

72 lbs.
33 kg

APPLICATIONS:

Film & Video Post Production

5.1 Digital Format Subwoofer

PA System Installations

Recording Studio

Mastering Facility

Home Theater

Discotheque

S18E-I The S18E-I is a high output INFRA subwoofer system designed to provide high fidelity extended low frequency audio reproduction from a relatively small enclosure. The S18E-I provides perfectly flat response down to 8 Hertz when used in conjunction with the 8 Hertz Integrator. Designed for permanent installation, the S18E-I offers a flat black painted finish and a black coated steel grille.

ABOUT INFRASUB TECHNOLOGY Almost all specifications for subwoofer systems are fixated on the frequency response domain. However, the impression of power and quality is equally related to the time domain performance of a system. Because of the long wavelengths of low frequencies, this is particularly true with subwoofers.

Likewise, the maximum SPL is not a very reliable way to judge the impact of a subwoofer. A poor time domain performer will not have the same impact or natural sound as a time correct INFRA system.

The reason that INFRA technology sounds dramatically better than the others is because of their superior time domain performance. The INFRA subwoofer maintains the bass energy in a tight packet, aligned with the upper range signal, providing a greater body impact and a seamless musical connection with the main loudspeakers.

Conventional sub designs perform so poorly in the time domain because designers have used methods that sacrifice the phase response for more control over the frequency response (e.g., steep low pass filter slopes, vented speaker enclosures, and narrow bandwidth systems). With the INFRA technique, we do not degrade the phase response while extending the frequency response.

While the INFRA dual integrator does function as the system crossover, it does so without using a low pass filter. Adding a low pass filter, analog or digital, will have a degrading effect on the time domain performance of the INFRA subwoofer. A low pass filter adds signal delay to the sound which varies with frequency. Also, narrowing the pass band increases the influence of the rolloff on both ends of the subwoofer spectrum. The result is the smearing of the arrival times of the low frequency sound components, changing the timbre and downgrading the impact of transient sounds.

The Bag End INFRA subwoofers are designed as no-compromise, high fidelity reproduction systems. We believe they are the finest subs available, regardless of price.

BAG END Loudspeakers
22272 Pepper Road
Barrington, Illinois
60010 USA
Voice 847 382 4550
Fax 847 382 4551
www.bagend.com





S18E-I

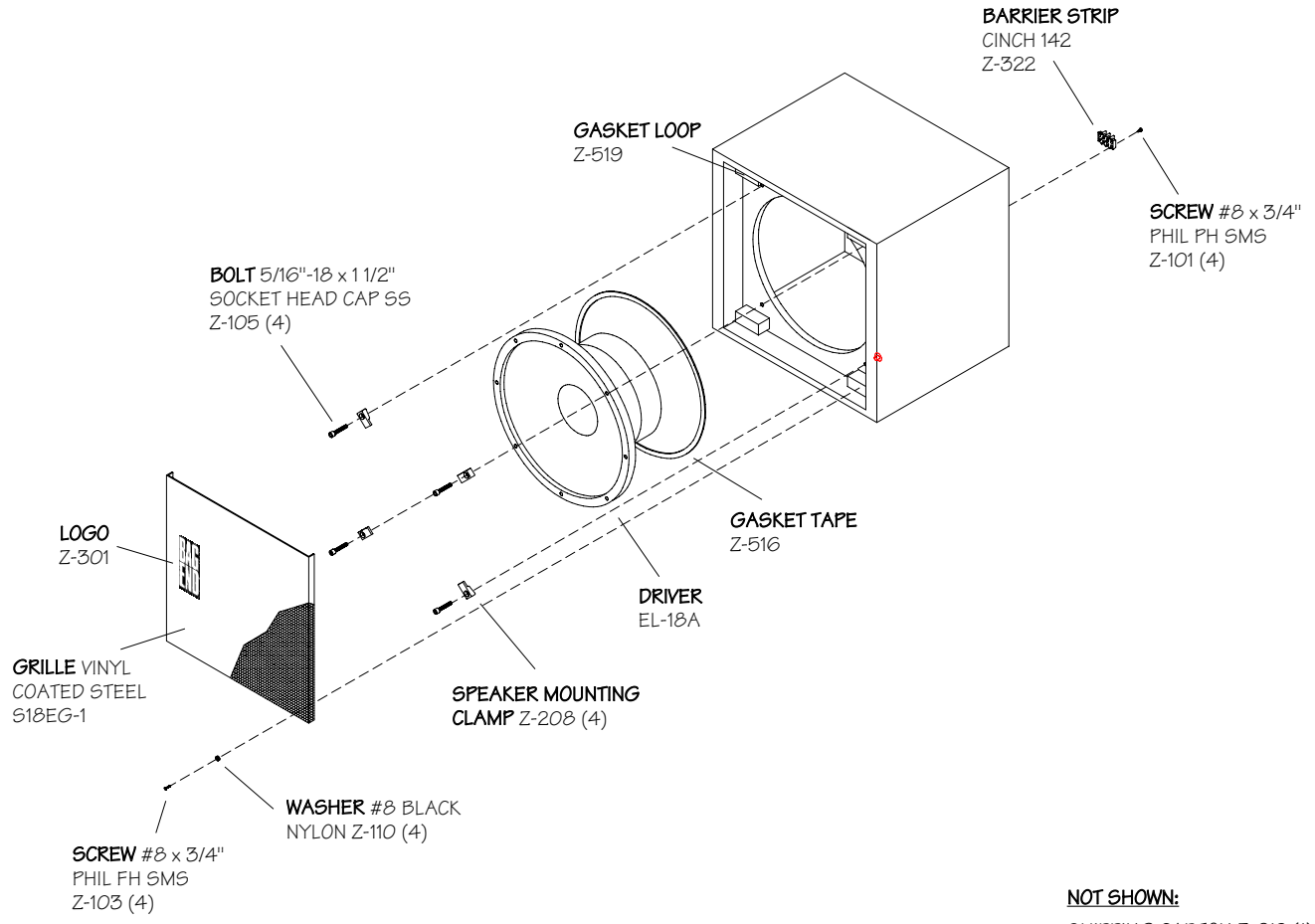

NOT SHOWN:

- SHIPPING CARTON Z-612 (1)
- PLASTIC BAG Z-627 (1)
- CORNER GUARD Z-629 (8)
- EDGE GUARD Z-630 (20)

SYSTEM SCHEMATIC

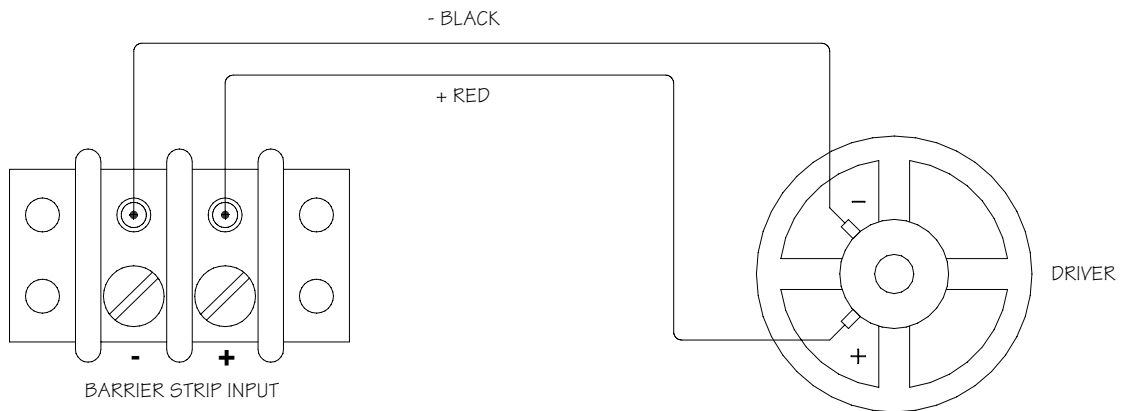

⊕ = Center of Gravity

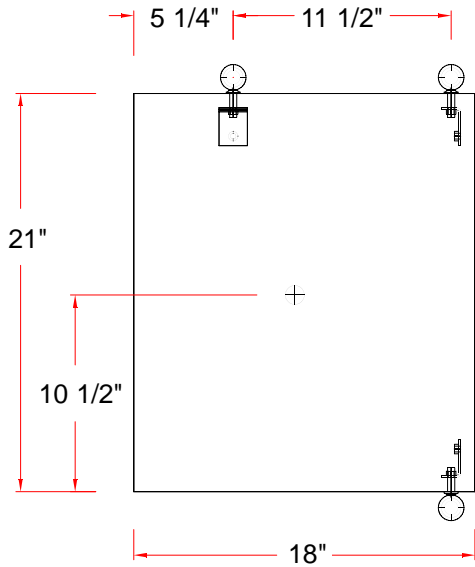

Side View

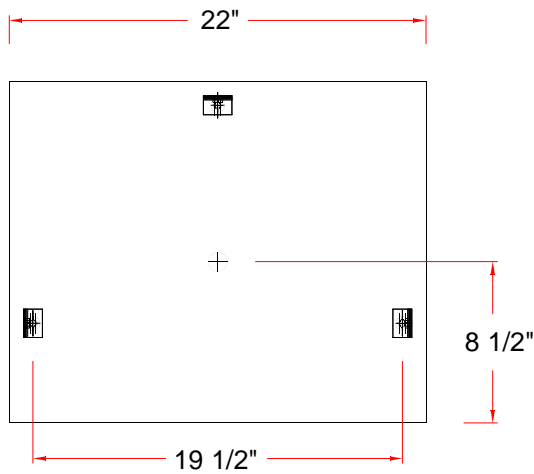
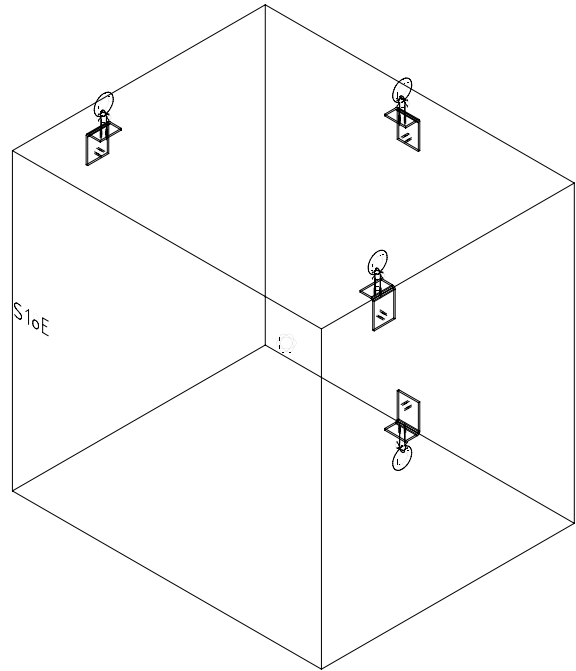

Top View

Warning:

Mounting and rigging loudspeakers requires experienced professionals. Improperly installed loudspeakers can result in property damage, personal injury, death and/or liability to the installing contractor.

F4 option includes flypoints as shown, plus 3 x 5/16"-18 forged shoulder eyebolts.

BAG END Loudspeakers
22272 Pepper Road
Barrington, Illinois
60010 USA
Voice 847 382 4550
Fax 847 382 4551
www.bagend.com

