



SYSTEM COMPONENTS

Enclosure:

3/4" MDF
Floor monitor angle: 30°

Low Frequency Transducer:

12" Cone
2.5" Voice coil
80 oz. Magnet

High Frequency Transducer:

1" Exit compression driver
1.8" Titanium diaphragm
15 oz. Magnet
Radial horn

Input Connectors:

1 - Dual banana
2 - 1/4" Phone
2 - Neutrik Speakon

Grille:

Black nylon cloth over wood frame

ACOUSTIC AND ELECTRICAL

System Type:

2-way vented 0.9 ft³

Impedance:

8 Ω

Crossover Network:

Passive Time-Align® equalizer type at 2.5 kHz

Time Offset Between Drivers:

< ± 25 Microseconds

Frequency Response:

75 Hz to 20 kHz ±3 dB
(2π Steradians)

Sensitivity:

101 dB SPL (1W @ 1m)

Dispersion:

80° Horizontal (-6 dB)
60° Vertical (-6 dB)
(Horn may be rotated 90° for a 60° H x 80° V dispersion)

Power Handling:

200 W continuous sine wave
800 W instantaneous peak

PHYSICAL

Finish:

Oak wood veneer

Dimensions:

21" h x 14" w x 11.5" d
54 cm x 36 cm x 30 cm

Weight:

44 lbs.
20 kg

Shipping Dimensions:

24" x 17" x 15"
61 cm x 44 cm x 39 cm

Shipping Weight:

49 lbs.
23 kg

APPLICATIONS:

Live Stage Monitoring

Vocal Monitor

Electronic Keyboards

Acoustic Guitar Monitor

TA1200-OF The TA1200-OF is a compact portable full range floor monitor loudspeaker system offering both high fidelity and high efficiency. The Time-Aligned™ studio quality sound provides detail and clarity not found in other designs. With flat frequency response and Time-Alignment™, the TA1200-OF requires almost no equalization and delivers clear intelligible vocal reproduction with excellent gain before feedback abilities.

About Time-Align® Time-Align® assures that the fundamental and overtones of a complex, transient, acoustical signal are presented to the listener in the same relationship as the electrical signal at the input terminals of the loudspeaker.

The conventional loudspeaker spreads out the sound in time: when a rapid series of transients occur the results are blurring and lost detail. With Time-Align®, a transient is presented as a tight package of energy, with the same time relationships as the natural sound. This means that a rapid series of transients will be heard clearly.

True Time-Alignment™ requires much more than just physically lining up the loudspeaker components. It requires consideration of the driver placement, driver delay and adjustment of the crossover delay parameters. This achieves the precise simultaneous acoustical arrival time of each driver throughout the crossover region.

Along with state-of-the-art laboratory instruments, the proprietary Time-Align® generator, built by Ron Wickersham, is used in designing our loudspeaker systems. The Time-Align® generator is founded upon different underlying mathematical principles than are used in the more common Fourier based measurement equipment.

When comparing a genuine BAG END Time-Aligned™ speaker system to any other, our additional design work is easy to hear and appreciate. The dramatic clarity, realism, and overall pleasant sound of our Time-Aligned™ loudspeakers is noted throughout the world.

BAG END Loudspeakers
22272 Pepper Road
Barrington, Illinois
60010 USA
Voice 847 382 4550
Fax 847 382 4551
www.bagend.com





TA1200-OF

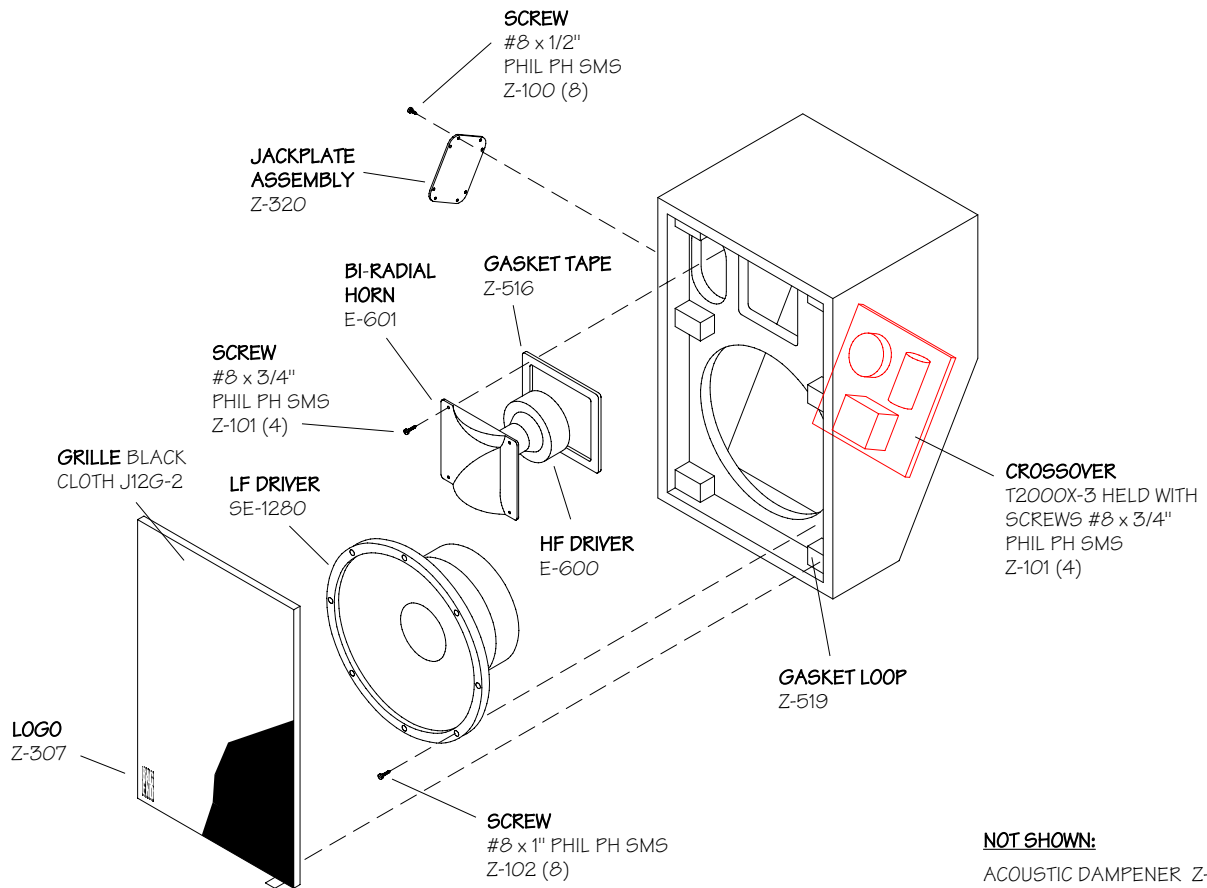

- NOT SHOWN:**
- ACOUSTIC DAMPENER Z-500 (4)
 - SHIPPING CARTON Z-623 (1)
 - PLASTIC BAG Z-626 (1)
 - EDGE GUARD Z-630 (8)
 - CORNER GUARD Z-629 (12)

SYSTEM SCHEMATIC

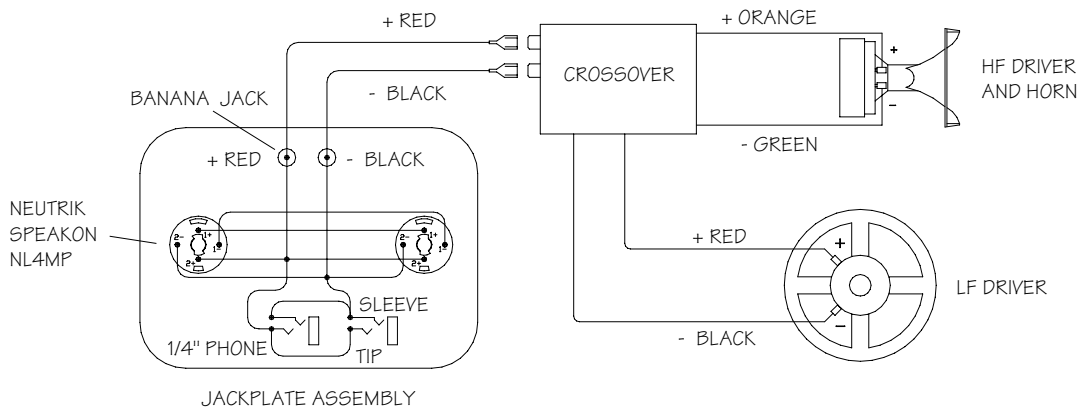

The Neutrik Speakon NL4MP connector is a keyed, high current, four conductor device which allows both the high and low frequency signals for a bi-amped loudspeaker system to run through the same 4-conductor cable. Note that all four conductors on both connectors are wired in parallel, but only two conductors are connected to the drivers in the enclosure. This permits an easy parallel connection to other similar loudspeakers (if your amplifier can handle the low impedance load!) and allows the use of a short "jumper" between the subwoofers and the mid/high speakers in a bi-amped system. Banana and 1/4" phone jacks are also provided.