

# ALTMAN Lighting

BRINGING IMAGINATION TO LIGHT

## CHALICE 150 PENDANT DOWNLIGHT

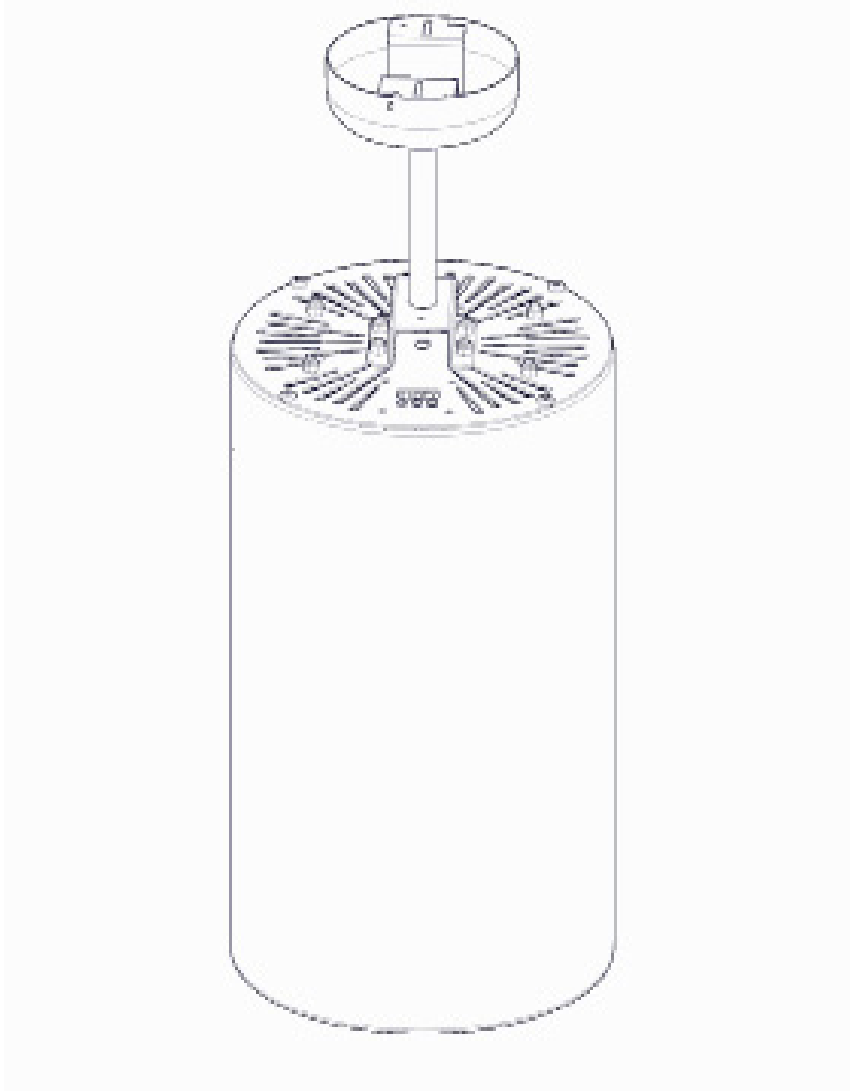

Chalice 150 - Pendant Down Light



Corporate Offices:

57 Alexander Street

Yonkers, NY 10701

(914)-476-7987

[www.altmanlighting.com](http://www.altmanlighting.com)

The material in this manual is for information purposes only and is subject to change without notice. Altman Lighting assumes no responsibility for any errors or omissions which may appear in this manual. For comments and suggestions regarding corrections and/or updates to this manual, please visit the Altman Lighting web site at [www.altmanlighting.com](http://www.altmanlighting.com) or contact your nearest Altman Lighting Regional Manager.

El contenido de este manual es solamente para información y está sujeto a cambios sin previo aviso. Altman Lighting con no asume responsabilidad por errores o omisiones que puedan aparecer. Cualquier comentario, sugerencia o corrección con respecto a este manual, favor de dirijirlo a la oficina de Altman Lighting más cercana.

Der Inhalt dieses Handbuches ist nur für Informationszwecke gedacht, Aenderungen sind vorbehalten. Altman Lighting uebernimmt keine Verantwortung für Fehler oder Irrtuemer, die in diesem Handbuch auftreten. FürBemerkungen und Verbesserungsvorschlaege oder Vorschlaege in Bezug auf Korrekturen und/oder Aktualisierungen in diesem Handbuch, moechten wir Sie bitten, Kontakt mit der naechsten Altman Lighting Niederlassung aufzunehmen.

Le matériel décrit dans ce manuel est pour information seulement et est sujet à changements sans préavis. La compagnie Altman Lighting n'assume aucune responsabilité sur toute erreur ou ommission inscrite dans ce manuel. Pour tous commentaires ou suggestions concernant des corrections et/ou les mises à jour de ce manuel, veuillez s'il vous plait contacter le bureau de Altman Lighting le plus proche.

---

Note: Information contained in this document may not be duplicated in full or in part by any person without prior written approval of Altman Lighting Its sole purpose is to provide the user with conceptual information on the equipment mentioned. The use of this document for all other purposes is specifically prohibited.

---

Document Number: 49-0230

Version as of: 20160513

## IMPORTANT INFORMATION

---

When using electrical equipment, basic safety precautions should always be followed including the following:

- a. READ AND FOLLOW ALL SAFETY INSTRUCTIONS.
- b. Do not use outdoors.
- c. Do not mount near gas or electric heaters.
- d. Equipment should be mounted in locations and at heights where it will not readily be subjected to tampering by unauthorized personnel.
- e. The use of accessory equipment not recommended by the manufacturer may cause an unsafe condition.
- f. Do not use this equipment for other than intended use.
- g. Refer service to qualified personnel.

SAVE THESE INSTRUCTIONS.

**WARNING:** You must have access to a main circuit breaker or other power disconnect device before installing any wiring. Be sure that power is disconnected by removing fuses or turning the main circuit breaker off before installation. Installing the device with power on may expose you to dangerous voltages and damage the device. A qualified electrician must perform this installation.

**WARNING:** Refer to National Electrical Code® and local codes for cable specifications. Failure to use proper cable can result in damage to equipment or danger to personnel.

**WARNING:** This equipment is intended for installation in accordance with the National Electric Code® and local regulations. It is also intended for installation in indoor applications only. Before any electrical work is performed, disconnect power at the circuit breaker or remove the fuse to avoid shock or damage to the control. It is recommended that a qualified electrician perform this installation.

**WARNING:** The Lighting Fixture IS NOT for residential installation or use.

**THIS PRODUCT MUST BE INSTALLED IN ACCORDANCE WITH THE APPLICABLE INSTALLATION CODE BY A PERSON FAMILIAR WITH THE CONSTRUCTION AND OPERATION OF THE PRODUCT AND THE HAZARDS INVOLVED.**

**CE PRODUIT DOIT ÊTRE INSTALLÉ SELON LE CODE D'INSTALLATION PERTINENT, PAR UNE PERSONNE QUI CONNAÎT BIEN LE PRODUIT ET SON FONCTIONNEMENT AINSI QUE LES RISQUES INHÉRENTS.**

## FCC NOTICE

---

This equipment has been tested and found to comply with the limits for a Class A digital device, pursuant to part 15 of the FCC Rules. These limits are designed to provide reasonable protection against harmful interference when the equipment is operated in a commercial environment. This equipment generates, uses, and can radiate radio frequency energy and, if not installed and used in accordance with the instruction manual, may cause harmful interference to radio communications.

Operation of this equipment in a residential area is likely to cause harmful interference in which case the user will be required to correct the interference at his own expense.

## DMX 512 ADDITIONAL RESOURCES

---

For more information on installing DMX512 control systems, the following publication is available for purchase from the United States Institute for Theatre Technology (USITT), "Recommended Practice for DMX512: A Guide for Users and Installers, 2nd edition" (ISBN: 9780955703522). USITT Contact Information:

USITT (United States Institute for Theater Technology)  
315 South Crouse Avenue, Suite 200  
Syracuse, NY 13210-1844  
Phone: 1.800.938.7488 or 1.315.463.6463

## ALTMAN LIGHTING STANDARD WARRANTY

---

Altman Lighting, Inc., a subsidiary of Altman Stage Lighting Company, Inc., herein referred to as Altman, warrants each new product (except for spare parts or products Altman does not manufacture) for a period of TWO (2) years from date of shipment to correct by repair or replacement any part defect due to faulty material or workmanship. Under these same terms, products with an LED light source shall be warranted for a period of THREE (3) years. The customer must receive a Return Material Authorization (RMA) number prior to return. Return shipments must be visibly marked with the RMA number; the product must be returned (shipping prepaid) to the factory at:

Altman Lighting Inc.  
57 Alexander Street  
Yonkers, NY 10701  
[www.altmanlighting.com](http://www.altmanlighting.com)

The return must be within THIRTY (30) days of receiving the RMA from Altman. Altman warrants for NINETY (90) days any spare part it manufactures. On spare parts or products Altman does not manufacture, such as lamps, sockets, lenses, roundels, electronics, ignitors, ballasts, etc.; Altman will grant the same warranty given Altman by its vendors.

Altman assumes no responsibility for damage or faulty performance caused by misuse, improper installation, careless handling or where repairs have been attempted by others.

This warranty is in lieu of all warranties or guarantees expressed or implied and no representative or person is authorized to assume Altman any other liability with the sale of Altman's products.

## TABLE OF CONTENTS

---

Important Information	1
FCC Notice , DMX Resources, Altman Standard Warranty	2
Table of Contents - this page	3
About this Manual	4
Product Descriptions - Part Number Ordering	4
Accessories - Reflectors & Mounting options	4
Typical Mounting - Canopy	5
Product Mounting - Air Craft Cable	6/7
Product Mounting - Yoke Mount / Wall Mount	8
Luminaire Wiring - Power / Data	9/10
Luminaire Controls	10
Operation and Programming	11/12
Display Information	13
Cleaning and Care	14
Trouble Shooting	15
Technical Specifications	16
Optical Specification	16

## ABOUT THIS MANUAL

This document provides installation and operation instructions for the following products: Chalice 150 single point Pendant Down Light (refer to "Product Descriptions" for individual product models). Please read all instructions before installing or using this product. Retain this manual for future reference. Additional product information and descriptions may be downloaded at [www.altmanlighting.com](http://www.altmanlighting.com)

## PRODUCT DESCRIPTIONS

The Chalice 150 down light follows the Altman Lighting tradition of lighting quality. Designed specifically for the demands of theaters, churches and public venues, the Chalice 150 is a 145W White LED pendant fixture that is an energy-efficient solution to general lighting needs. The Chalice 150 addresses and alleviates the typical maintenance routines of changing lamps and ballasts in difficult-to-access locations. The Chalice 150 uses a single-point source for optimal beam control, and offers a variety of reflector options for ceiling heights from 15 to 50 feet. Its powerful and clean non-pixelated and non-granulated output blends to seamless coverage in the most elegant setting. Extremely smooth dimming reproduces the comfortable feel of traditional incandescent sources, at a fraction of the power consumption. Either Mains Dimmer or DMX control allows each fixture to be controlled independently or in groups, from an architectural control system and/or directly from a theatrical control console. This Manual covers the following Chalice 150 Single Point Pendant Downlight Luminaire models:

Model	Description
CD*150 -**_***_****_*****	Chalice 150 Single Point 135W LED Pendant Mount Downlight
* (Mounting Method)	P = Pendant, W= Wall, Y = Yoke
** (CCT)	2K, 3K, 4K, & 5K (Nb.2K = 2700 Kelvin)
*** (Body Color)	B=Black, W=White, S= Silver, C= Custom
****	D= DMX, M = Mains Dim (-120 or -220)
***** (Dim Curve Setting)	120=120V, 220= 220V (Mains Dim Only)

Typical Part numbering scheme:

CDPSP-3K-B-D (Chalice SP Pendant Mount - 3000 Kelvin - Black Body color - DMX 512 Control)

## ACCESSORIES

Accessories - Reflectors	Description
19-F13379	20 Degree Narrow Spot Reflector
19-F13380	29 Degree Spot Reflector
19-F13325	39 Degree Narrow Flood Reflector
19-F13381	46 Degree Medium Flood Reflector
19-F13401	51 Degree Wide Flood Reflector
19-F13402	64 Degree Very Wide Flood Reflector
19-F13838 **	91 Degree Extra Wide Flood Reflector

\*\* NOTE: Some Clipping of the beam will occur with the use of this 91 Degree Extra Wide Flood Reflector. Please see Chalice 150 IES files for beam characteristics.

## ACCESSORIES

Accessories	Description
99-C545-S-*	Ball Mount Assembly (* Color) BL=BLack, WH=WHite, SL=SiLver
70-3980	Aircraft Cable Suspension Assembly
SS-8CDL-DMXTERM	DMX 120-Ohm Terminator Kit (note: Chalice 150 DMX model offers a built in DMX terminator.)

## TYPICAL MOUNTING - Canopy with Pendant

### Canopy with Pendant

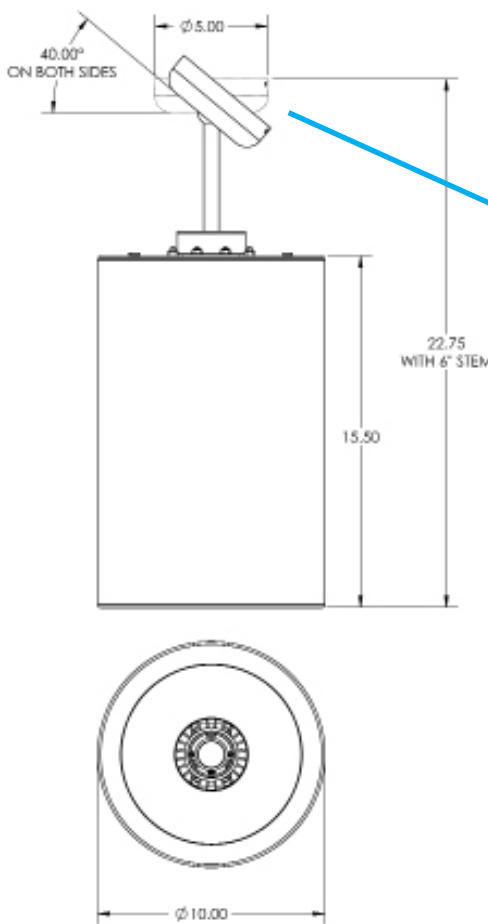

To Ceiling Mounted junction box.

Please note: both junction box and junction box screws are not included with the Chalice 150. Chalice 150 must be installed by qualified professional installer.

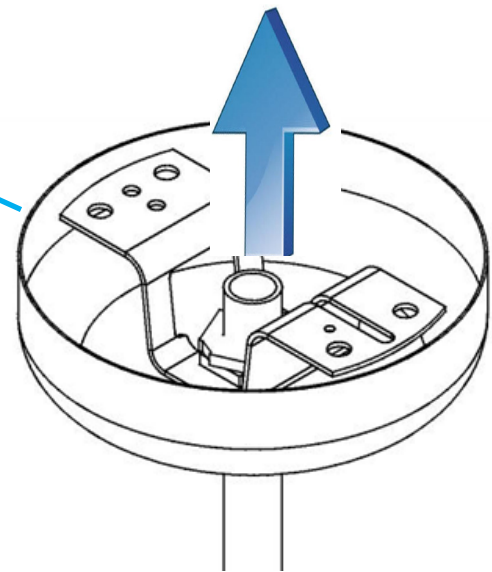

\*\* Special Note: the Chalice 150 Canopy is designed for 0 to 40 degree Ceiling installation. If the mounting of the Chalice 150 requires angled ceiling mounting, please make sure the that angle orientation slot is parallel with the angle of the sloped ceiling and is no greater than 40 degrees.

### WARNING:

Supporting mechanism and structure must be capable of supporting the weight of the Chalice 150.

For product technical information (including weight), refer to "TECHNICAL SPECIFICATIONS" on the last page of this manual. Check applicable codes in your area for specific requirements.

## PRODUCT MOUNTING - Air Craft Cable

### Aircraft Cable

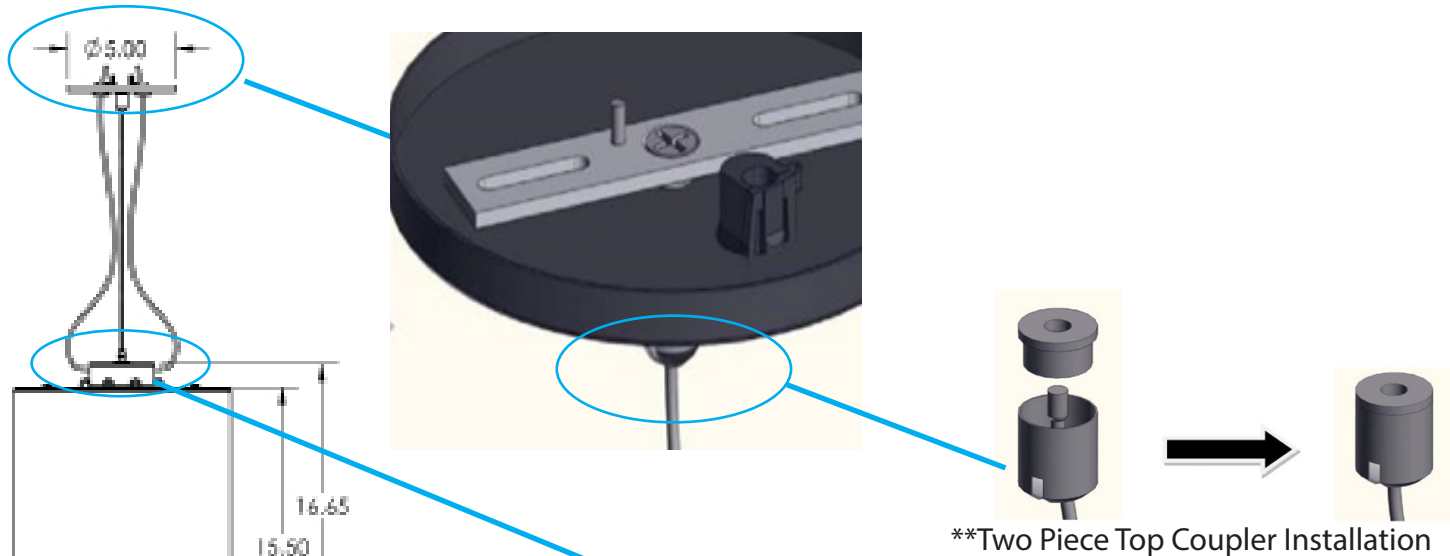

### Installing the 99-GR-1/4-IP Cable Gripper

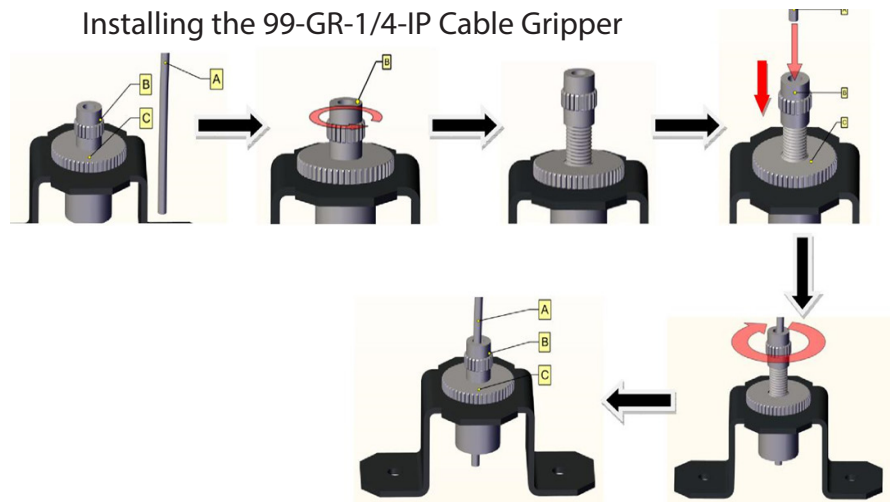

### WARNING:

Supporting mechanism and structure must be capable of supporting the weight of the Chalice 150.

For product technical information (including weight), refer to "TECHNICAL SPECIFICATIONS" on the last page of this manual. Check applicable codes in your area for specific requirements.

\*\* Special Note: the two piece top cable coupler is designed for 0 to 90 degree installation. If the mounting of the Chalice 150 requires angled ceiling mounting please make sure the that angle orientation slot is parallel with the angle of the sloped ceiling.



PRODUCT MOUNTING - Air Craft Cable - Parts Assembly

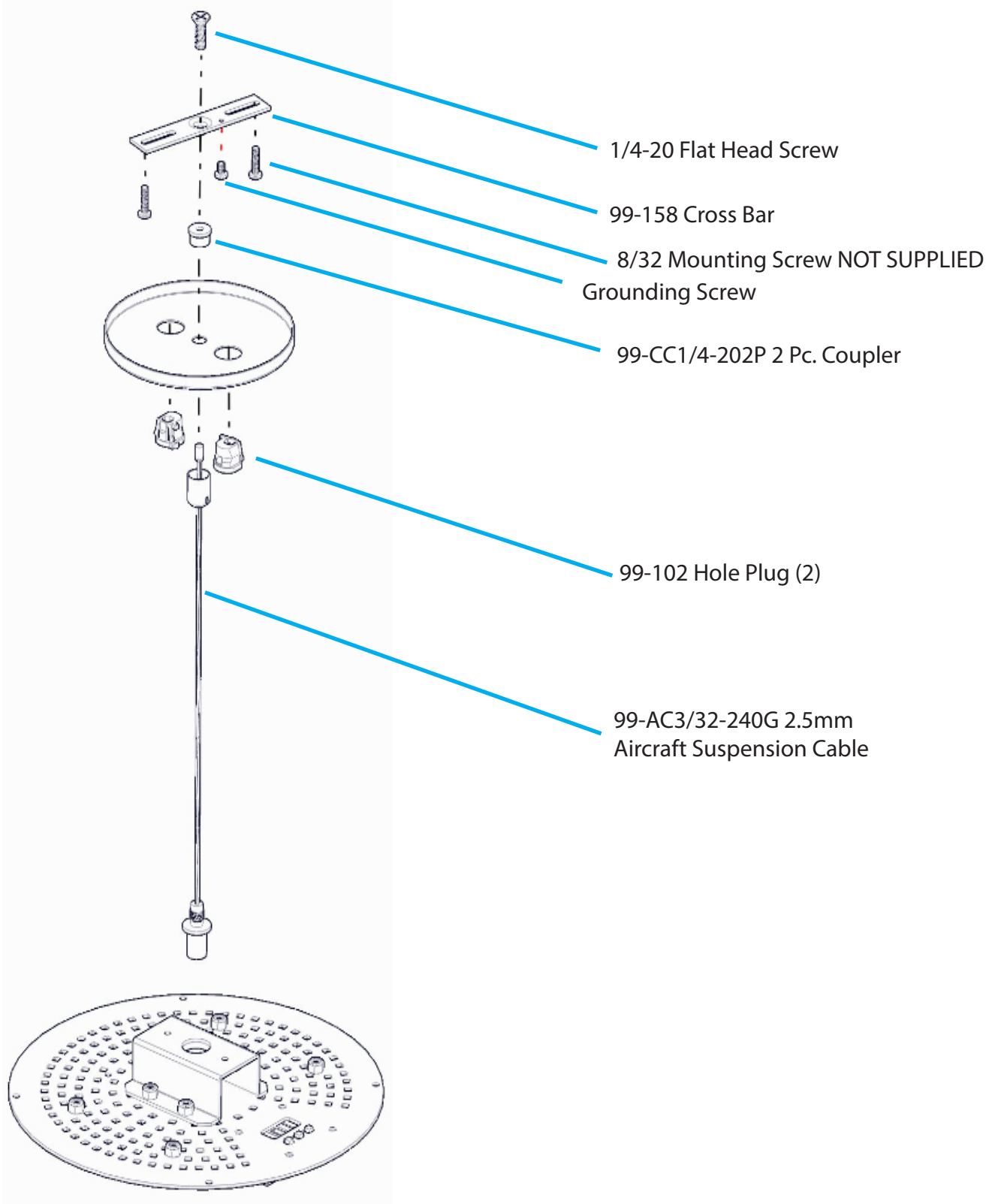

## PRODUCT MOUNTING - Yoke & Wall Mount

### Yoke Mount

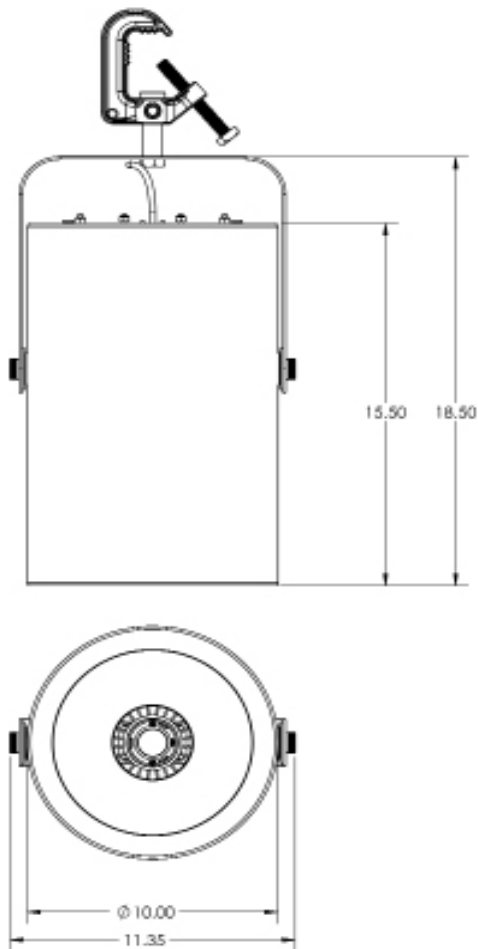

### Wall Mount

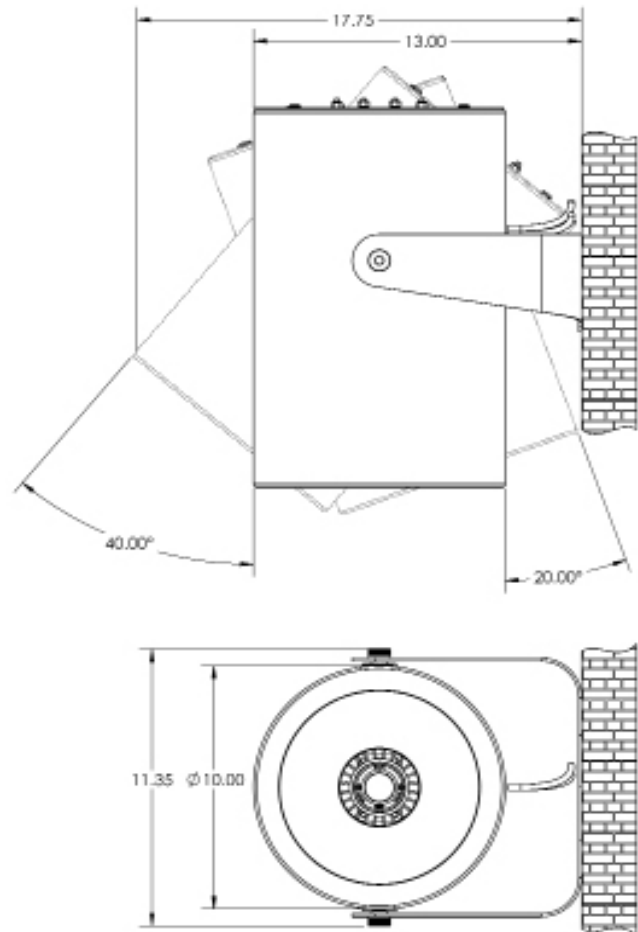

**WARNING!** To prevent injury or death, you must have access to a main circuit breaker or other power disconnect device before installing any wiring. Be sure that power is disconnected by removing fuses or turning the main circuit breaker off before installation. Installing the device with power on may expose you to dangerous voltages and damage the device. A qualified electrician must perform this installation.

Note: The Chalice 150 Luminaire is intended for installation in accordance with the National Electric Code and local regulations. To assure full compliance with local codes and regulations, check with your local electrical inspector before installation. The Chalice 150 is not intended for residential use or installation.

LUMINAIRE WIRING

DMX CONNECTION	WIRE COLOR	HARDWIRE CONNECTION
DMX INPUT	White/Orange	Data In (+)
	Orange	Data In (-)
	White/Brown	Data In Common
DMX OUTPUT	White/Green	Data Out (+)
	Green	Data Out (-)
	Brown	Data Out Common

NOTE: (DMX Version) Chalice 150 utilizes One (1) piece of Category 5 Belden 1592A cable for all Data connectivity. Three (3) of the conductors are used for data input and three (3) conductors for data output. The White/Blue & Blue conductors are not used.

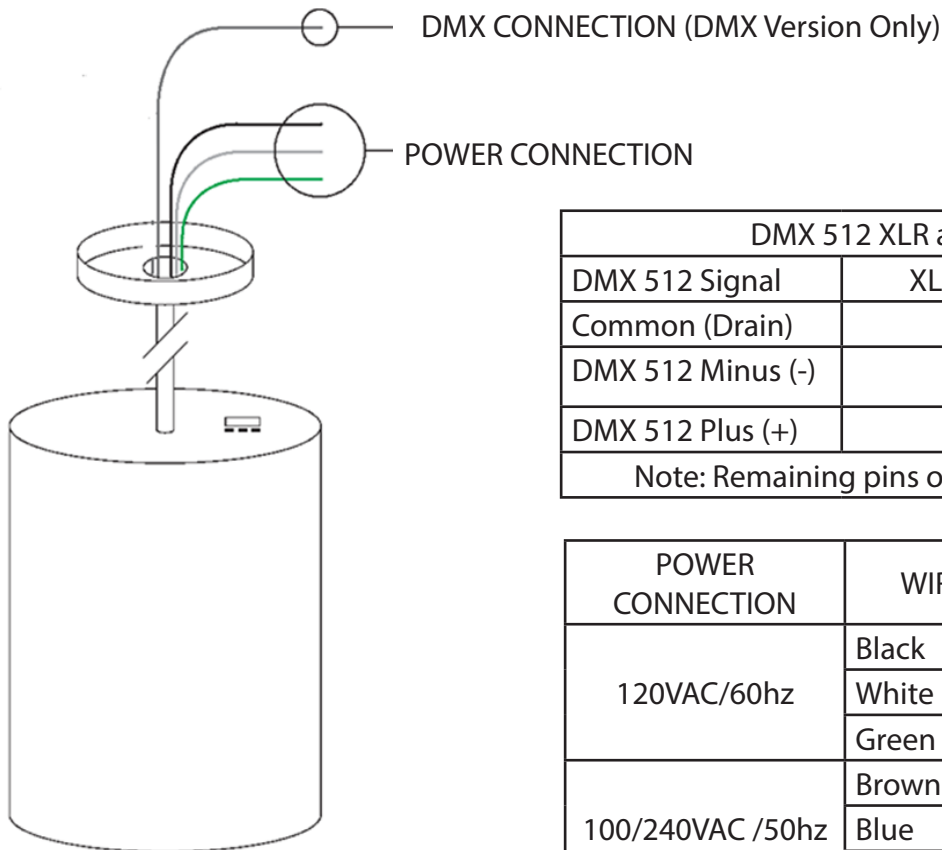

DMX 512 XLR and RJ45 Connections		
DMX 512 Signal	XLR Pin	RJ45 Pin
Common (Drain)	1	7
DMX 512 Minus (-)	2	2
DMX 512 Plus (+)	3	1
Note: Remaining pins on each connector are not used		

POWER CONNECTION	WIRE COLOR	HARD WIRE CONNECTION
120VAC/60hz	Black	Hot / Mains
	White	Common - Neutral
	Green	Earth - Ground
100/240VAC /50hz	Brown	Hot / Mains
	Blue	Neutral
	Green/Yellow	Earth - Ground

## LUMINAIRE WIRING - MAINS DIM MODEL

**POWER CONNECTION - MAINS DIM MODEL:** The Chalice 150 should be connected to a Phase cut dimmer either forward or reverse phase and set to the appropriate voltage. Typical Phase Cut dimmers include SCR's (Silicon Controlled Rectifiers), IGBT's (Insulated Gate Bipolar Transistors), and TRIAC dimmers).

The Chalice 150 Luminaire operates on 100 to 240 volts AC (+/- 10%, auto-ranging). Depending on supply voltage, each luminaire can draw up to 140 Watts. The maximum through current should not exceed 20 Amps\*.

**NOTE MAINS DIM CONTROL MODE: DO NOT CONNECT MORE THAN FOUR (4) CHALICE 150'S TO THE SAME DIMMER. CONNECTING MORE THAN FOUR UNITS ON THE SAME DIMMER WILL RESULT UNDESIRE LOW END DIMMER REPOSSES.**

NOTE: The Chalice 150 is shipped preset for your dimming voltage. 115 or 220 VAC internal jumper is preset for 115 VAC for 120VAC Models and 230 VAC for 230 VAC models.

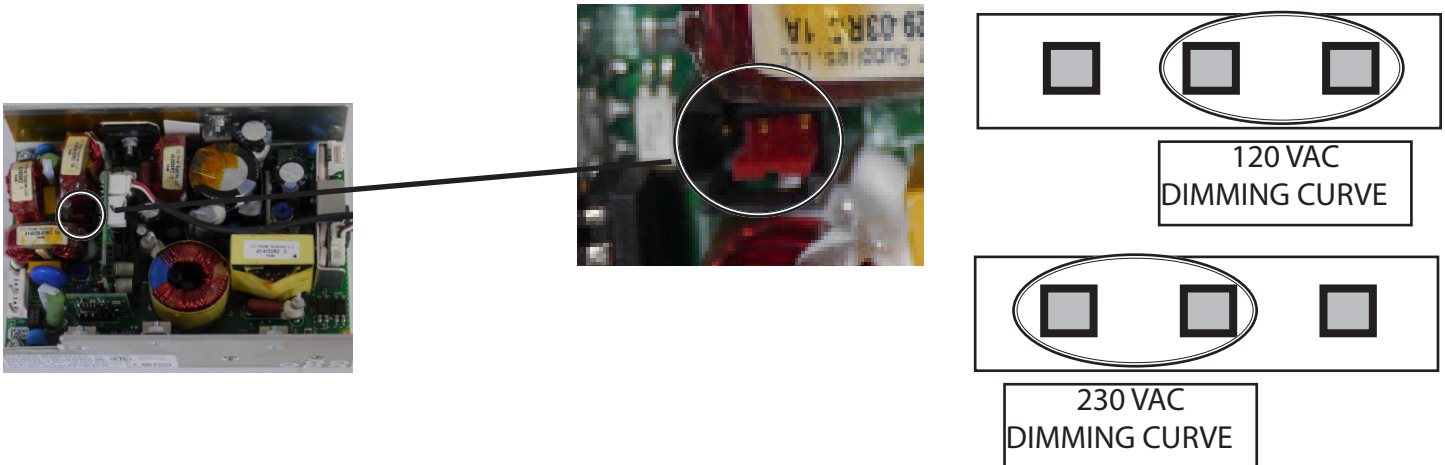

**WARNING: DO NOT** Daisy chain both MAINS DIMMABLE Luminaires with Luminaires that require CONSTANT POWER. When the CDP 150 is connected to a dimming system ONLY CDP 150 Luminaires should be daisy chained together. Failing to follow these guidelines will result in unwanted dimming performance and damage to the luminaires.

## Connecting to a DMX Network

Basic DMX512 installation consists of connecting multiple Chalice150 Luminaires together (up to 32 Total devices per DMX string) in "daisy-chain" fashion. A cable runs from the control console (or DMX512 control source) to the DMX INPUT connection on the first Chalice 150 Luminaire. From the DMX OUTPUT of this Chalice 150 another cable runs to the DMX IN connector on the next Chalice 150 Luminaire (or DMX512 device to be controlled).

Special Note: at the end of each DMX Daisy chain, it is highly recommended that a SS-8CDL-DMXTERM 120 OHM resistor be utilized to properly terminate the DMX signal.

NOTE: When valid DMX is present the "Ones" decimal point will remain illuminated.

**POWER CONNECTION - DMX MODEL :** The Chalice 150 Luminaire should be connected to either a constant circuit or relay device. Note: Altman Lighting recommends that all Non-Dim circuits powering solid state luminaires are routinely powered down to both conserve energy and maximize luminaire performance.

## LUMINAIRE CONTROLS - DMX MODEL

The Chalice 150 Single Point luminaire's three digit control system provides set up and local control for accessing all of the luminaires menu options and settings.

Upon Power-up, the three digit display will sequence:

1. Firmware Version: (vXX) where XX = Version number Displays for 2 seconds,
2. Absence of DMX: (oFF, HLd, PrE, FuL) [ Default: oFF ] Displays for 2 seconds,
3. Preset Level(L01 ~ L99) [ Default: L99 ] Displays for 2 seconds,
4. Locked State (Loc, unL) [ Default: unL] Displays for 2 seconds,
5. Control / ReceiveState (Con , rEC) [ Default: rEC] Displays for 2 seconds,
6. DMX Termination: (I-I or ----) I-I = Termination on 120ohm resistor active for DMX end of line termination; ---- = DMX Termination OFF [Default: ----]  
999 = Termination OFF, 998 = Termination ON
7. Pxx Set: Personality (dimming curve)  
601 = Linear, 602 = Incandescent fade 1, 603 = Incandescent fade 2
8. DMX address: (001~512)– This is the DMX channel number. [ Default: 001] Displays for 4 seconds ;

NOTE: When valid DMX is present the "Ones" decimal point will remain illuminated.  
When Luminaire has DMX termination ON the "Hundreds" Decimal point will blink.

To initiate Info Display sequence, do the following button sequence: Wait a few seconds until the display goes blank,

1. press and hold the [ TENS ] button,
2. press and hold the [ HUNDREDS ] button,
3. release the [ TENS ] button,
4. release the [ HUNDREDS ] button.

Pressing any button in any mode activates display if it is blank, and shows appropriate display for the Operating mode.

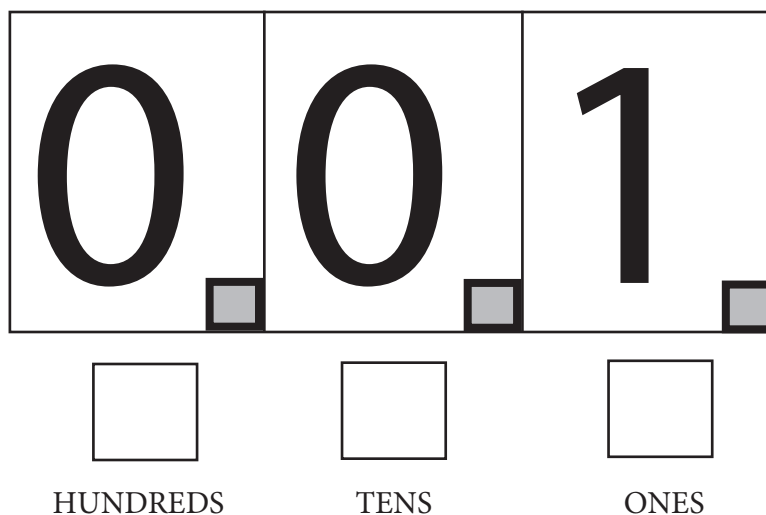

## OPERATION AND PROGRAMMING - DMX MODEL

There are two (2) main Operating modes:

### 1. DMX mode:

The Chalice 150's dimming level is set via a DMX controller. This controller controls the luminaire via DMX 512a. This address can be from 001 - 512. To programming a different DMX address:

1. Depress the Hundreds, Tens, and Ones, selection switches to the desired DMX address number (001 to 512).
2. The display goes blank\* and comes back again, confirming the new DMX address, displays it for 4 seconds, then display goes blank\*.

[ Default DMX address 001 ]

NOTE: When valid DMX is present the "Ones" decimal point will remain illuminated.

### 2. Standalone mode:

When in Standalone mode, the Chalice 150 does not require a DMX control signal.

To enter Standalone mode (or exit back to DMX mode):

Wait a few seconds until the display goes blank\*, then do the following button sequence:

1. press and hold the [ ONES ] button,
2. press and hold the [ TENS ] button,
3. release the [ ONES ] button,
4. release the [ TENS ] button. When in Standalone mode the unit will ignore DMX input, once in Standalone mode the ONES and TENS indicator will remain lit.
5. Unit Preset level is set (0 to 100%) using [ TENS ] and [ ONES ] buttons : (00 to 99) (L00=0%), (L99=100% full).
6. IMPORTANT NOTE: Unit must be in Control State (below) in order for above output to take effect.

#### A. Control / Receive State:

Note: Only one unit per DMX string should be set to Control State to avoid data conflict.

When in Standalone Mode the Chalice 150 can also enter into a Control State. The Luminaire will transmit its Preset level on DMX channel 1, so that it acts like a console to control the other units that are connected via DMX cable. If unit is in DMX mode, Control State will do nothing.

When in Receive State, Unit only receives DMX, and if set to DMX channel 1, it will imitate the other unit that is set to Control State, if connected.

To Toggle between Control and Receive state, do the following button sequence:

Wait a few seconds until the display goes blank,

1. press and hold the [ HUNDREDS ] button,
2. press and hold the [ ONES ] button,
3. release the [ HUNDREDS ] button,
4. release the [ ONES ] button;

Once in Con State the ONES, TENS, & HUNDREDS Indicator will remain Lit.

Display will blink and show Con (or rEC) for 4 seconds and then go to current mode display.

[Default is Receive State]

## OPERATION AND PROGRAMMING -DMX MODEL

### Absence of DMX:

When connected to a DMX network, if there is a loss of signal the following settings will effect the behavior of the Chalice 150 upon signal loss. This mode can be programmed by entering a number greater than 900. There are four (4) different options upon the loss of signal.

SETTING	DISPLAY [RDM]	DESCRIPTION
901	oFF [00]	off (dimmed to 0%) [Default]
902	HLd [01]	hold last look (retains last DMX level)
903	PrE [02]	preset (Standalone Preset level)
904	FuL [03]	full on (100%)

NOTE: upon loss of valid DMX setting 904 will initiate an instant change in the light output from the DMX setting to FULL ON (100%)

When this is done, after 2 sec, the display will change the [ HUNDREDS ] digit to [P], asking for confirmation of personality change. This is confirmed with a press of [ ONES ] button. Pressing any other button reverts back to 90X series display so that modification can be made.

Once confirmation is made:

Display blinks and shows new Absence of DMX setting (oFF, HLd, PrE, FuL) for 4 sec, then goes to current mode display.

### Locked State:

When in Locked State, Buttons will have no effect until they are unlocked. To Lock (or unlock) the buttons, do the following button sequence:

Wait a few seconds until the display goes blank,

1. press and hold the [ ONES ] button,
2. press and hold the [ HUNDREDS ] button,
3. release the [ ONES ] button,
4. release the [ HUNDREDS ] button.

Display will blink and show Loc (or unL) for 4 sec and then go to current mode display.  
[ Default is unlocked]

### \*Display Notes:

Display goes completely blank after 4 seconds, except :

1. If in DMX Mode and DMX signal is detected;  
then: [ONES] decimal point will stay lit
2. If in Standalone Mode, and Receive State;  
then: [TENS] and [ONES] decimal point will stay lit;
3. If in Standalone Mode, and Control State;  
then: [HUNDREDS], [TENS] and [ONES] decimal point will stay lit.

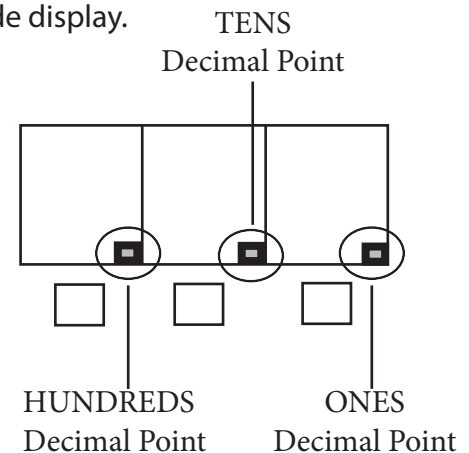

## OPERATION AND PROGRAMMING - DIMMING CURVE AND DMX TERMINATION

### DIMMING CURVE:

The CDP150 DMX Model will replicate one of three programmed dimming curves replicating linear and incandescent dimming.

SETTING	DISPLAY [RDM]	DESCRIPTION
601	P01 [0]	Linear
602	P02 [1]	Incandescent Fade 1
604	P03 [2]	Incandescent Fade 2 (fast Bottom)

### SETTING DIM CURVE:

1. Wait for Display to go blank (decimal points may still be active depending upon termination and DMX presence).
2. Using the programming buttons set the desired DIMMING CURVE setting
3. Wait 2 seconds, the display will then will change the [ HUNDREDS ] digit to a [P], asking for confirmation of personality change.
4. Depress the [ ONES ] button to confirm personality change Pressing any other button reverts back to 60X series display so that modification can be made.
5. Depress the [ONES] button a second time to return out of programming mode.

## DMX TERMINATION -DMX MODEL

### DMX TERMINATION:

The CDP150 DMX Model is supplied with a programmable DMX terminator built into the luminaire. In a DMX system it is recommended that the luminaire that is at the end of the DMX Daisy-chain is terminated using a 120 OHM resistor which the CDP 150 offers in the settings below.

SETTING	DISPLAY [RDM]	DESCRIPTION
998	I---I [0]	Termination ON
999	---- [1]	Termination OFF

### SETTING DMX TERMINATION:

1. Wait for Display to go blank (decimal points may still be active depending upon termination and DMX presence).
2. Using the programming buttons set the desired DMX TERMINATION setting
3. Wait 2 seconds, the display will then will change the [ HUNDREDS ] digit to a [P], asking for confirmation of personality change.
4. Depress the [ ONES ] button to confirm personality change Pressing any other button reverts back to 90X series display so that modification can be made.
5. Depress the [ONES] button a second time to return out of programming mode.



## CLEANING AND CARE

---

**WARNING!** All cleaning should be performed with power completely removed from the luminaire. Never remove protective covers when luminaire is powered. Wear appropriate protective eye wear and gloves when cleaning the fixture. All service and maintenance, other than described herein, should be performed by a qualified technician or Authorized Service Center.

### 1. Special Cleaning and Care Instructions

Being a solid-state fixture, and unlike most fixtures, the Chalice 150 Luminaire requires very little routine maintenance by the user. This section covers portions of the luminaire that can be removed for cleaning.

The Chalice 150 Luminaire requires special care when it comes to cleaning the front reflector assembly. Additional care needs to be taken with the plastic components because they are much easier to scratch or damage than glass.

The following is a list of cleaning materials required to care for your Chalice 150 Luminaire:

- Lint free lens tissue
- Lint or powder free gloves
- Reagent grade isopropyl alcohol\*
- A mild soap solution.

**Note: \*Reagent grade isopropyl alcohol is good to use on the Chalice 150 Luminaire plastic optics with anti-reflection coatings.**

If the lens is still dirty after using isopropyl alcohol, for instance if fingerprints or oil is just redistributed and not cleaned off the optic, then a mild soap and water solution can be used to gently wash the lens. Repeat the cleaning with isopropyl alcohol to eliminate streaks and soap residue.

**WARNING!** Under no circumstances should ammonia-based cleaners, acetone, or other harsh solvents be used on or near the Chalice 150. These types of cleaners or solvents can permanently damage the optics or housings of the fixture. If you have any questions regarding the use or care of your Chalice 150 LED Luminaire, please contact Altman Lighting technical support or your local Authorized Dealer.

### 2. Front Lens / Reflector Cleaning

To clean the front lens and reflector:

Step 1. Turn off luminaire and allow to cool completely.

Step 2. Apply a small amount of reagent grade isopropyl alcohol to lint-free lens tissue.

Step 3. Wipe all debris, dirt, fingerprints, etc. from lens and reflector.

Step 4. Using a second lint-free lens tissue, wipe off any alcohol residue.

### 3. Service and Maintenance

For all other service and maintenance issues, please contact your local Altman Lighting offices or an [Authorized Service Center](#).

## TROUBLE SHOOTING -DMX / MAINS DIM MODEL

**WARNING!** Any service and maintenance (including troubleshooting), other than described herein should be performed by an Authorized Altman Lighting Dealer or Service Center.

<b>Description</b>	<b>Symptom</b>	<b>Possible Cause / Remedy</b>
No Light Output-DMX MODEL	Fixture will not produce Light output but has power. Display is illuminated or internal LED is illuminated.	Unit Setting is at 0% Local control Unit Setting is at 0% DMX control Set Level above 0% or adjust to a higher intensity.
No Power at Luminaire - DMX / MAINS MODEL	Luminaire does not power up.	Circuit is not energized, Verify circuit power and circuit breaker has been turned on. Not Plugged in, ensure viable power source and unit is plugged in. Verify power cabling is wired correctly (see page 9 for details)
DMX Data Control - DMX MODEL	Fixture will not respond to DMX Commands.	Not detecting DMX data, Disconnect and reconnect DMX input cable. Unit is set in Stand Alone mode. DMX Connection not wired properly see page 9 for details. DMX address is different than that of the DMX controller.
LED is not Responding -DMX / MAINS MODEL	Fixture is powered but no light output.	Luminaire is in an Overtemperature condition. Remove power from the luminaire and allow unit to cool before re-energization.
Luminaire not coming to full intensity - MAINS MODEL	When the Dimmer is at full unit only shows 1/2 intensity.	120/230 VAC jumper is in the wrong location. Move jumper to proper jumper location for appropriate dimming voltages. See page 10 for details
Local Programming -DMX MODEL	Unit will not allow programming changes	See page 11 - 13 for step by step on setting up DMX and stand alone control.

## TECHNICAL SPECIFICATIONS.

Source:	145 Watt Fixed White LED emitter
Light	Output: > 10,000 Lumens ** interdepdant upon reflector choice
Lumens/Watt	74.0 **
CRI	> 90
Color Temperature:	Choice of 2700, 3000, 4000, & 5000 Kelvin White
Input Voltage:	100 -277 VAC 50/60hz - DMX MODEL 100 -240 VAC 50/60hz - MAINS DIM MODEL
Current DMX MODEL:	1.2Amps (@120VAC) 0.68Amps (@220VAC) 0.58Amps (@277VAC)

Current (MAINS DIM MODEL):	1.01A @ 120 VAC 0.50A @240 VAC
----------------------------	-----------------------------------

Power Factor (MAINS DIM MODEL): >.92 full load

Current Inrush (MAINS DIM MODEL):	15Apk Max 1/2 cycle @230VAC.
Quiescent Load:	3.1 Watts (DMX MODEL ONLY)
Ambient Temperature:	0 to 40 degrees C (32 to 104 degrees F)
Humidity:	5%-95% Non condensing
Cooling:	Fanless Convection Cooling
Weight:	17.6 pounds (8kg) luminarie only.
Compliance:	ETL / cETL Listed

## OPTICAL SPECIFICATION

Reflector Type	Lumen Output	10'-0" (3.048m)	20'-0" (6.096m)	30'-0" (9.144m)	40'-0" (12.192m)
20 Degree Narrow Spot	10746	515.4 fc (5547.7 Lux)	130.1fc (1400.3 Lux)	58.52 fc (629.9 Lux)	33.73 fc (363 Lux)
29 Degree Spot	9697	227.4 fc (2447.7 Lux)	58.36 fc (628.1 Lux)	26.67 fc (287.0 Lux)	15.41 fc (165.87 Lux)
39 Degree Narrow Flood	8983	112.4 fc (1209.8 Lux)	28.81 fc (310.1 Lux)	13.25 fc (142.6 Lux)	7.89 fc (84.9 Lux)
46 Degree Medium Flood	8845	135.7 fc (1460.6 Lux)	35.02 fc (376.9 Lux)	15.92 fc (171.3 Lux)	9.32 fc (100.3 Lux)
51 Degree Wide Flood	9155	93.95 fc (1011 Lux)	24.96 fc (268.6 Lux)	11.46 fc (123.3 Lux)	6.69 fc (72.0 Lux)
64 Degree Very Wide Flood	9260	84.7 fc (911.7 Lux)	21.96 fc (236.3 Lux)	10.28 fc (110.6 Lux)	6.08 fc (65.4 Lux)
91 Degree Extra Wide Flood	9200	47.5 fc (511.3 Lux)	12.9 fc (138.8 Lux)	6.3 fc (67.8 Lux)	3.23 fc (34.7 Lux)



Corporate Offices:  
57 Alexander Street  
Yonkers, NY 10701  
(914)-476-7987  
[www.altmanlighting.com](http://www.altmanlighting.com)

Document Number: 49-0230  
Version as of: 20160513

Chalice 150 Luminaire Installation & User's Manual  
©2016 Altman Stage Lighting Co. Inc., All rights reserved.