

datavideo

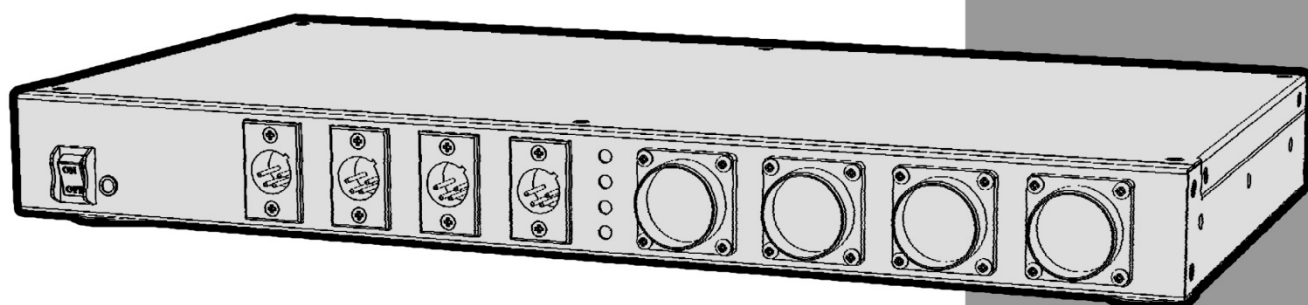

**CAMERA CONTROL
UNIT KIT**

CCU-100

Instruction Manual

www.datavideo.com

Table of Contents

Warnings and Precautions	- 2 -
Warranty	- 2 -
Standard Warranty.....	- 2 -
Two Year Warranty.....	- 3 -
Disposal	- 3 -
1. Product Overview	- 4 -
1.1 Features.....	- 4 -
2. Example CCU-100 Studio System based on Datavideo Products	- 5 -
3. CCU-100 Connections & Controls	- 6 -
3.1 Front Panel	- 6 -
3.2 Rear Panel	- 7 -
4. AD-2 (S/P/J) Connections & Controls	- 8 -
4.1 Front View	- 8 -
4.2 Rear View	- 9 -
4.3 Side View.....	- 10 -
4.4 Top View.....	- 11 -
4.5 Bottom View.....	- 12 -
5. RMC-240 Connections & Controls	- 12 -
6. HP-3 Connections & Controls	- 12 -
6.1 Features.....	- 12 -
7. Frequently-Asked Questions	- 13 -
8. Specifications	- 14 -
9. Service & Support	- 17 -

Disclaimer of Product and Services

The information offered in this instruction manual is intended as a guide only. At all times, Datavideo Technologies will try to give correct, complete and suitable information. However, Datavideo Technologies cannot exclude that some information in this manual, from time to time, may not be correct or may be incomplete. This manual may contain typing errors, omissions or incorrect information. Datavideo Technologies always recommend that you double check the information in this document for accuracy before making any purchase decision or using the product. Datavideo Technologies is not responsible for any omissions or errors, or for any subsequent loss or damage caused by using the information contained within this manual. Further advice on the content of this manual or on the product can be obtained by contacting your local Datavideo Office or dealer.

Warnings and Precautions

1. Read all of these warnings and save them for later reference.
2. Follow all warnings and instructions marked on this unit.
3. Unplug this unit from the wall outlet before cleaning. Do not use liquid or aerosol cleaners. Use a damp cloth for cleaning.
4. Do not use this unit in or near water.
5. Do not place this unit on an unstable cart, stand, or table. The unit may fall, causing serious damage.
6. Slots and openings on the cabinet top, back, and bottom are provided for ventilation. To ensure safe and reliable operation of this unit, and to protect it from overheating, do not block or cover these openings. Do not place this unit on a bed, sofa, rug, or similar surface, as the ventilation openings on the bottom of the cabinet will be blocked. This unit should never be placed near or over a heat register or radiator. This unit should not be placed in a built-in installation unless proper ventilation is provided.
7. This product should only be operated from the type of power source indicated on the marking label of the AC adapter. If you are not sure of the type of power available, consult your Datavideo dealer or your local power company.
8. Do not allow anything to rest on the power cord. Do not locate this unit where the power cord will be walked on, rolled over, or otherwise stressed.
9. If an extension cord must be used with this unit, make sure that the total of the ampere ratings on the products plugged into the extension cord do not exceed the extension cord rating.
10. Make sure that the total amperes of all the units that are plugged into a single wall outlet do not exceed 15 amperes.
11. Never push objects of any kind into this unit through the cabinet ventilation slots, as they may touch dangerous voltage points or short out parts that could result in risk of fire or electric shock. Never spill liquid of any kind onto or into this unit.
12. Except as specifically explained elsewhere in this manual, do not attempt to service this product yourself. Opening or removing covers that are marked "Do Not Remove" may expose you to dangerous voltage points or other risks, and will void your warranty. Refer all service issues to qualified service personnel.
13. Unplug this product from the wall outlet and refer to qualified service personnel under the following conditions:
 - a. When the power cord is damaged or frayed;
 - b. When liquid has spilled into the unit;
 - c. When the product has been exposed to rain or water;
 - d. When the product does not operate normally under normal operating conditions. Adjust only those controls that are covered by the operating instructions in this manual; improper adjustment of other controls may result in damage to the unit and may often require extensive work by a qualified technician to restore the unit to normal operation;
 - e. When the product has been dropped or the cabinet has been damaged;
 - f. When the product exhibits a distinct change in performance, indicating a need for service.

Warranty

Standard Warranty

- Datavideo equipment is guaranteed against any manufacturing defects for one year from the date of purchase.
- The original purchase invoice or other documentary evidence should be supplied at the time of any request for repair under warranty.
- Damage caused by accident, misuse, unauthorized repairs, sand, grit or water is not covered by this warranty.

- All mail or transportation costs including insurance are at the expense of the owner.
- All other claims of any nature are not covered.
- Cables & batteries are not covered under warranty.
- Warranty only valid within the country or region of purchase.
- Your statutory rights are not affected.

Two Year Warranty

- All Datavideo products purchased after 01-Oct.-2008 qualify for a free one year extension to the standard Warranty, providing the product is registered with Datavideo within 30 days of purchase. For information on how to register please visit www.datavideo-tek.com or contact your local Datavideo office or authorized Distributors
- Certain parts with limited lifetime expectancy such as OLED Panels, DVD Drives, Hard Drives are only covered for the first 10,000 hours, or 1 year (whichever comes first).

Any second year warranty claims must be made to your local Datavideo office or one of its authorized Distributors before the extended warranty expires.

Disposal

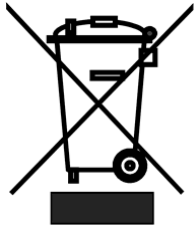

For EU Customers only - WEEE Marking

This symbol on the product indicates that it will not be treated as household waste. It must be handed over to the applicable take back scheme for the recycling of Waste Electrical and Electronic Equipment. For more detailed information about the recycling of this product, please contact your local Datavideo office.

1. Product Overview

This CCU-100 kit is designed to easily connect several Datavideo products into an effective and professional studio system. This guide assumes you may already own some or all of the other Datavideo products mentioned in this document. Where an asterix symbol (*) is shown next to a model number, this product is not supplied within the CCU-100 kit and an additional purchase may be required. Please speak with your dealer to discuss your desired set up using the Datavideo equipment you may already have. For more information on any of the products marked with an asterix (*) please visit our website www.datavideo.com

The CCU-100 kit can be used for passing on power to professional video cameras from the Datavideo PD-6* power centre and handling signals sent over the camera cables (CB-43 / 44 / 45 / 49*) to a switcher. In this way, it is used to remotely set up various camera parameters such as iris, shutter, gain, and master pedestal using an MCU-200 (S/P/J)*.

As well as passing on camera control signals, the CCU-100 system simultaneously handles digital SDI and analogue signals for camera video output, Program look back video, camera view finder data as well as tally and intercom signals between the cameras and a video switcher.

The Datavideo AD-2 (S/P/J), Multi Transmission Adaptor Box, is an adaptor box that allows connections between the CCU-100 Camera Control Unit and a single camera position. The CCU-100 and AD-2 (S/P/J) form part of an integrated cabling solution that allows you to get things done fast, easy and within a budget.

1.1 Features

- Control up to 4 cameras from one CCU-100 Camera Control Unit using the supplied AD-2 (S/P/J) units.
- Remote control of camera functions including Iris, shutter, gain, master pedestal etc
- HD/SD SDI video transmission from digital camera
- Transmission of view finder / monitor video signals
- Return look back video signal for camera operator
- Two-way intercom with camera operators using an ITC-100*
- Datavideo switcher tally support
- DC Power supply from 4-PIN XLR sources such as PD-6 Power Center*
- RJ-45 Port providing connection to MCU 100 (S/P/J) / 200 (S/P/J)* for Remote Control

2. Example CCU-100 Studio System based on Datavideo Products

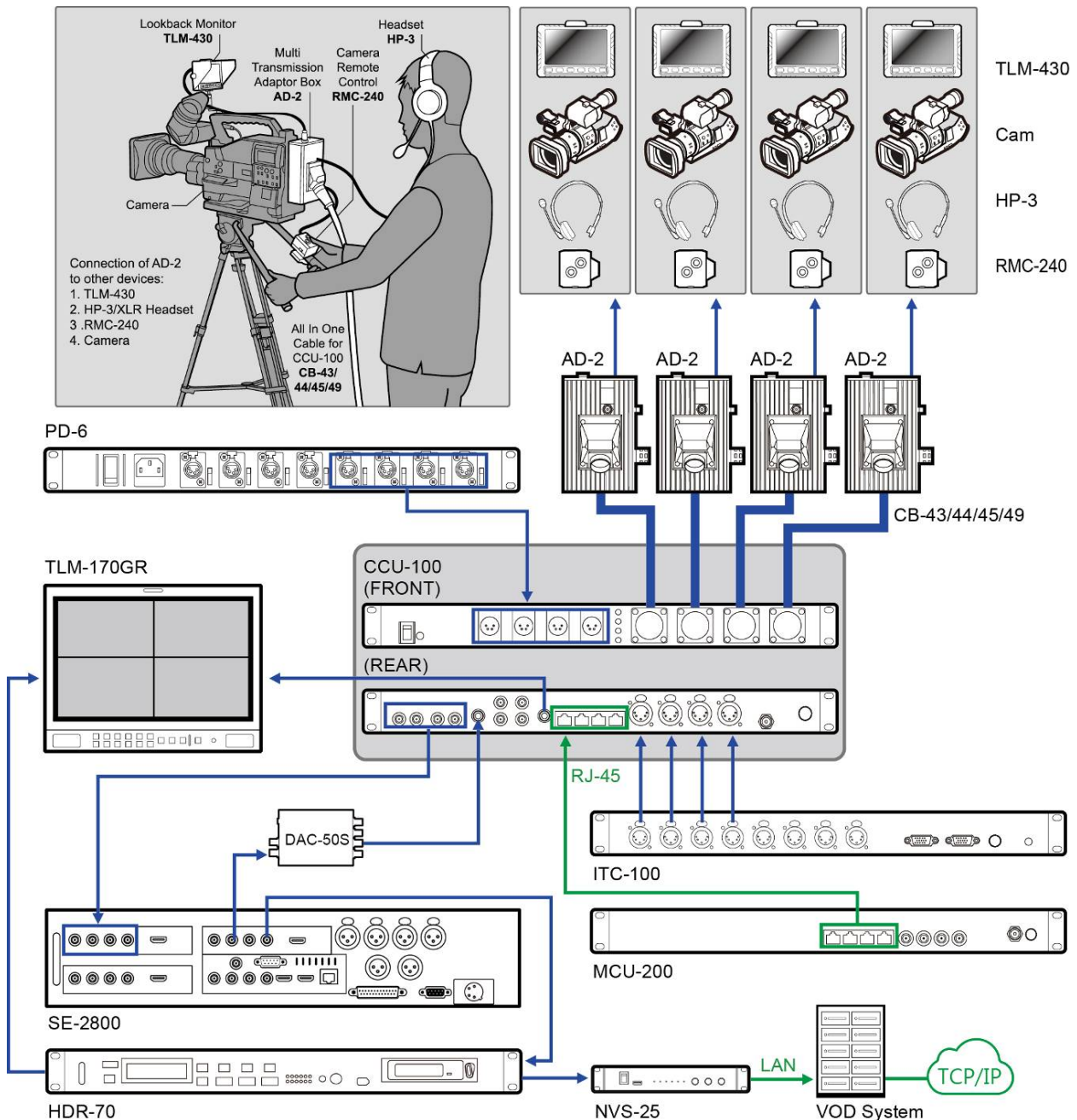

Communication between AD-2 (S/P/J) and CCU-100 is bidirectional. The signals in each direction are listed below:

CCU-100 – to – AD-2 (S/P/J)

- MCU-100 (S/P/J) / MCU-200 (S/P/J)* Control Signals
- Look Back Signal
- Power for camera and look back monitor
- Intercom System Signal
- Tally Light signal from switcher

AD-2 (S/P/J) – to – CCU-100

- Camera SDI Signal
- ITC-100* Intercom System Signal
- Camera View Finder Signal (composite video)

The View Finder Signals and the parameters are sent to the AD-2 (S/P/J), which in turn transmits to the TLM-430 for viewing. To display various camera parameters on the TLM-430*, simply press the Shot Mark button on the MCU-200 (S/P/J)*.

3. CCU-100 Connections & Controls

3.1 Front Panel

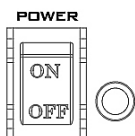
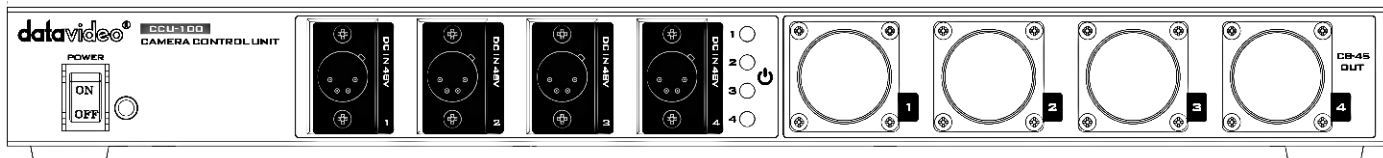

Power Switch

Switches the power On / Off.

Note: Make sure all cables are connected properly before turning on the power.

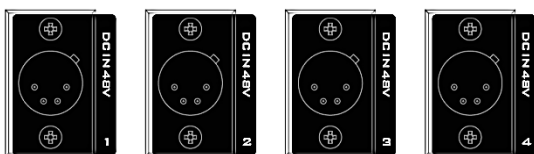

DC IN 48V

The CCU-100 is powered by the PD-6 Power Center.

Note: Make sure the power cable is plugged into the PD-6 60W DC Ports and the voltage is set to 48V. Locations of the 60W DC Ports are depicted in the diagram below enclosed in a rectangular box.

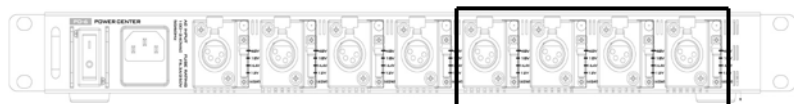

The 48V input will be converted by the AD-2 to a selectable power of 8.4V, 12V or 16.8V.

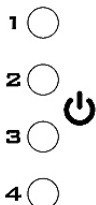

LED Indicators

LED indicating power status of the corresponding power connection

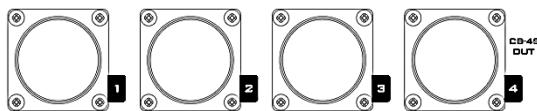

CB (all in one) cable connection (CB-43/ 44/ 45/ 49*)

Transmission of HD-SDI, MCU Control, Power, Look Back, View Finder, Intercom, and Tally between CCU-100 and AD-2 (S/P/J)

3.2 Rear Panel

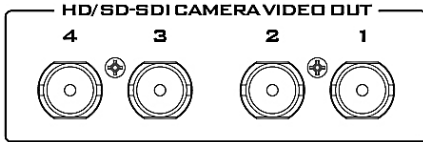
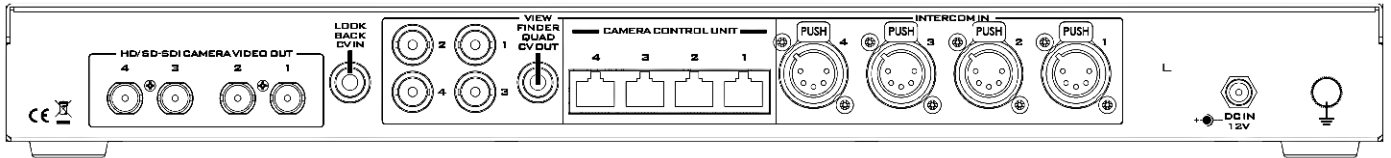

HD/SD-SDI Camera Video OUT

The CCU-100 provides four HD/SD-SDI camera video output channels. These outputs are generally connected to the switcher inputs.



Look Back CV IN

This receives the composite video Look Back PGM signal from the Switcher and allows signal transmission back to the camera operators.

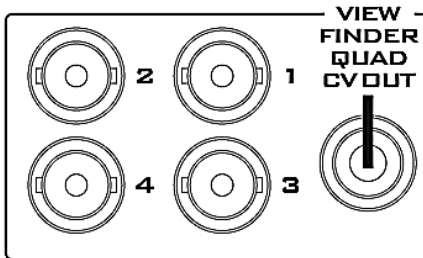

4 View Finder CV OUT / View Finder QUAD CV OUT

The four CV output connectors transmit composite video View Finder signals to the multiple individual monitors.

The View Finder Quad CV Out allows the user to view all four screens mentioned above as smaller images on just one composite video monitor.

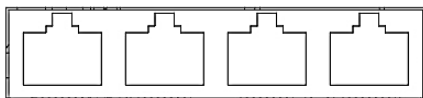

Ethernet Ports

These Ethernet ports are connected to the MCU-200 (S/P/J)* for remote control of cameras connected to CCU-100.

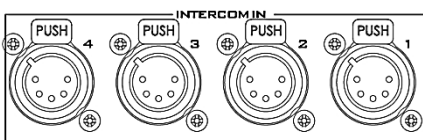

Intercom IN

These 5-PIN XLR connectors are connected to the ITC-100* Intercom System for receiving communication signals from the camera operators.



DC IN Socket

The DC IN socket receives power from the PD-2 Power Center. The power connection can be secured by screwing the outer fastening ring of the DC IN plug to the socket.



Grounding Terminal

When connecting this unit to any other component, make sure that it is properly grounded by connecting this terminal to an appropriate point. When connecting, use the socket and be sure to use wire with a cross-sectional area of at least 1.0 mm².

For more information on any of the products marked with an asterisk (*) please visit our website www.datavideo.com

4. AD-2 (S/P/J) Connections & Controls

AD-2 (S/P/J) is a Multi-Transmission Adaptor Box which is attached to the rear of the camera by a standard V-Mount plate as shown in the diagram below. It can also be used like a V-Mount Battery to power the camera. If the standard V-Mount plate is not found on the rear of the camera, the user can purchase a SLED (SLD-1) off the shelf from Datavideo.

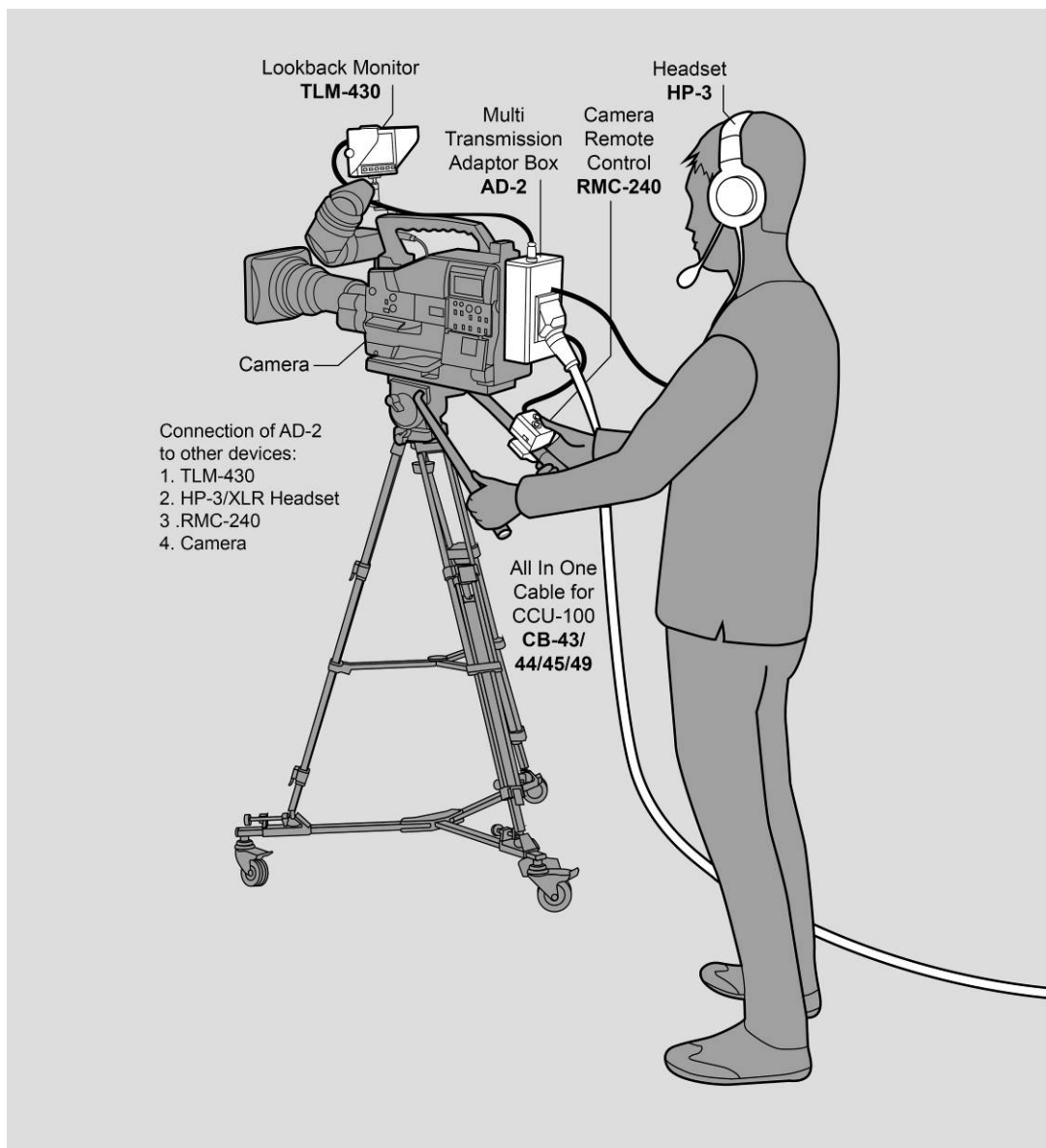

4.1 Front View

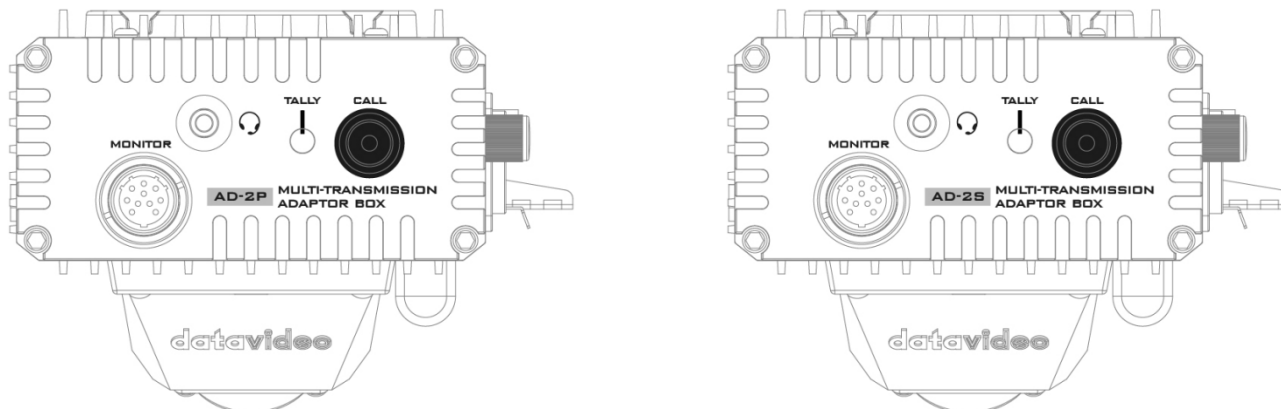

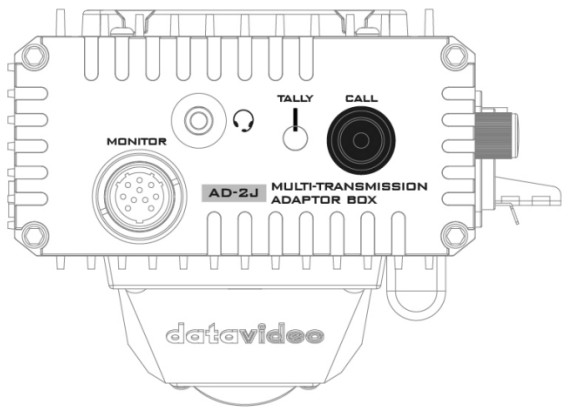

10-PIN Jack

Transmission of Tally, Power, Look Back PGM video, and View Finder from the AD-2 (S/P/J) to the TLM-430 monitor.



Call Button

The Call Button allows the camera operator to page the operator at the ITC-100 Intercom System with call tone via the CCU-100 Camera Control Unit.



3.5-mm Phone Jack Connector

This connector also allows the connection of other operator headsets / headphones to the AD-2 (S/P/J) and serves the audio signal transmission to and from the headsets. Headsets can be connected to this port via a music/TRS ¼" adaptor that comes with the CCU-100 product. Push the button on the adaptor to talk.



Bi-Color Tally LED

Will illuminate RED when the channel is LIVE
Green Color means the channel is CUED

4.2 Rear View

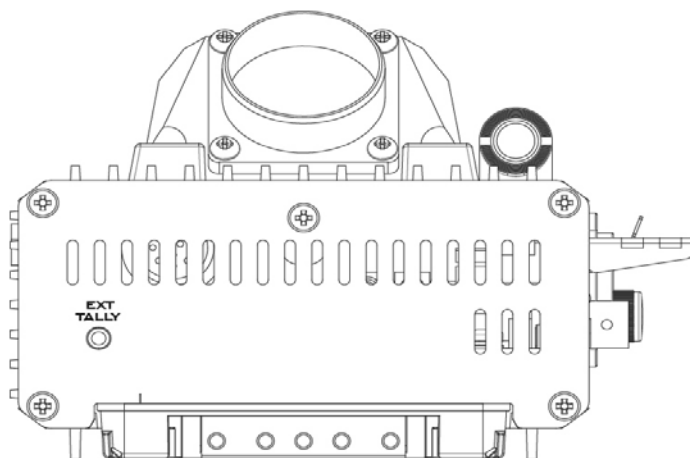

External Tally Socket

Transmission of tally information from AD-2 (S/P/J) to SLD-1 SLED

4.3 Side View

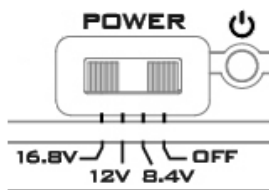
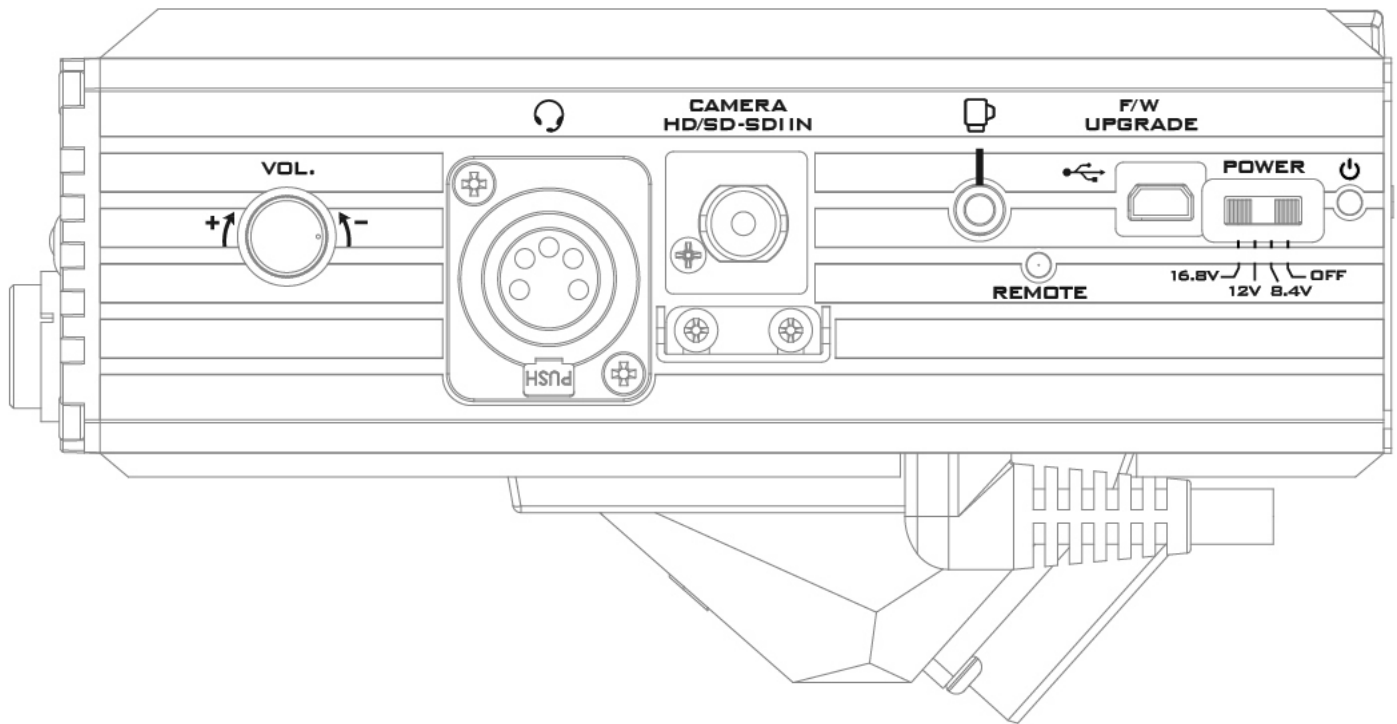

Power Switch

Selection of power output level (OFF/8.4 V/12 V/16.8 V) to camera

Power Indicator

Power Transmission Indicator

Green: 8.4 V

Amber: 12 V

Red: 16.8 V

Note: The 48V input will be converted by the AD-2 to a selectable power of 8.4V, 12V or 16.8V.



Mini USB Port

This USB port is reserved specifically for Firmware Upgrade.



3.5mm Jack

This connects to the RMC-240 remote control. This RMC-240 control allows the user to activate the communication between the connected headset and the Intercom System as well as switch between Look Back and View Finder monitor modes.



Camera Remote Control Link Indicator

Blue: Link Active

**CAMERA
HD/SD-SDI IN**

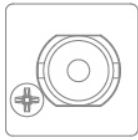

Camera HD/SD-SDI IN (BNC Connector)

This connector receives digital SDI video signal from the camera for transmission to the switcher connected to the CCU-100.

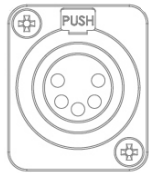

XLR Connector

AD-2 (S/P/J) has an XLR connector that allows use of HP-3 headsets, this supports camera operator communication to and from the ITC-100 Intercom System via the CCU-100 Camera Control Unit.



Volume Control Knob

This knob allows the user to adjust the audio volume for the connected headset.

4.4 Top View

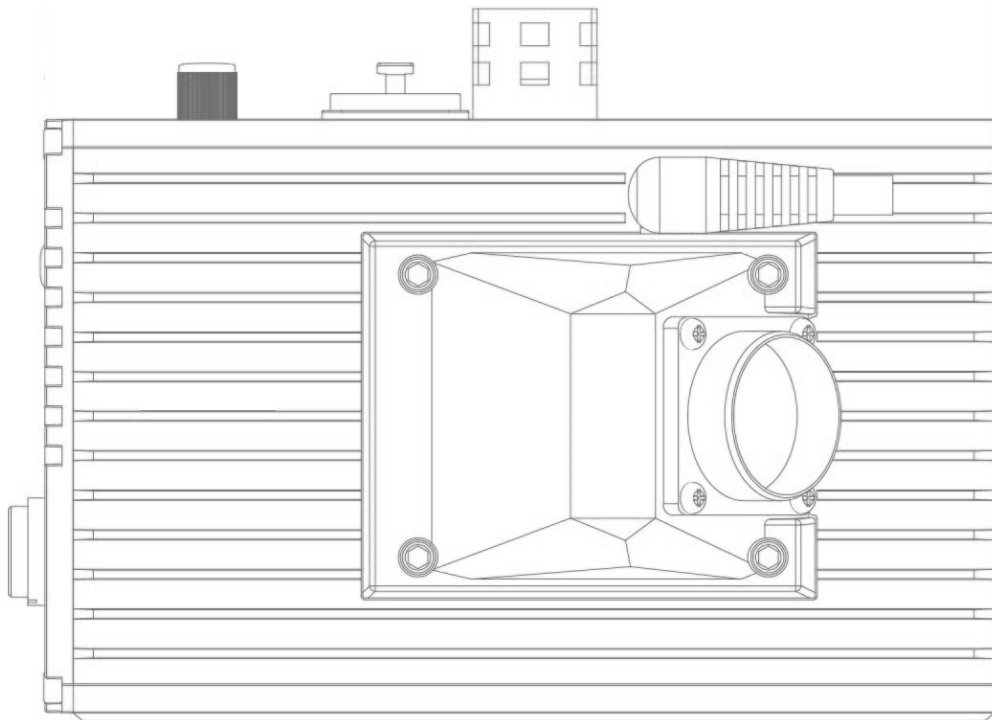

Camera Remote Control

8 PIN for SONY Cameras (PMW EX3, PMW 300K, PMW 350K, PMW F5, PDW-510, and HDW-F900R)

10 PIN for Panasonic Cameras (AG-HPX255 / 300 / 301 / 302 / 304 / 370 / 371 / 372 / 500 / 502 / 600, AJ-HDX900, and AJ-HPX2700G / 3000)

2.5 mm LANC Phone Jack / Multicore PS/2 for JVC Cameras (GY-HM890U, GY-HM850U, GY-HM650U, GY-HM600U and GY-LS300CHU)

4.5 Bottom View

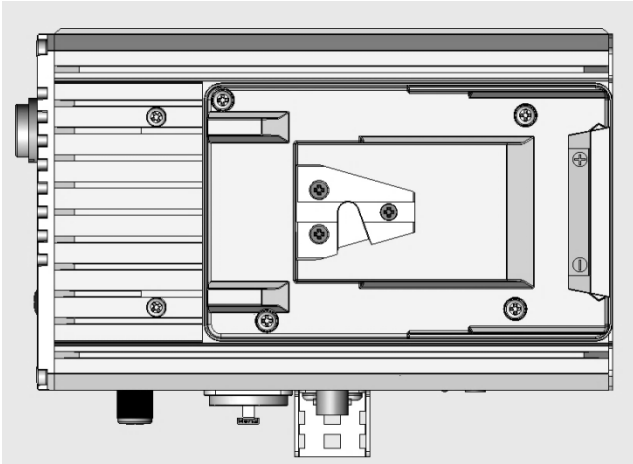

V-Mount Base

V-Mount base mounts AD-2 (S/P/J) to the rear of the camera

5. RMC-240 Connections & Controls

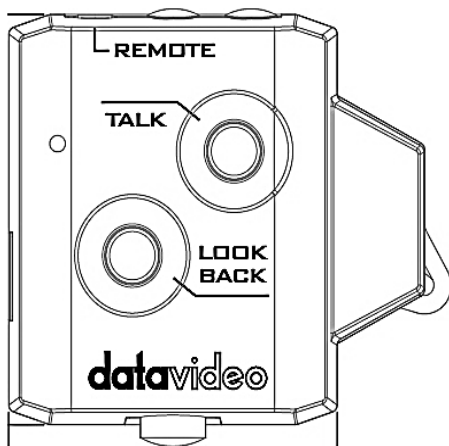

LOOK
BACK



TALK

Look Back Button

Press to switch between Look Back and View Finder TLM-430 monitor views.

TALK Button

Simply press to TALK. This Button is used to transmit the HP-3 audio signals from the AD-2 (S/P/J) XLR connector back to the ITC-100 Intercom System via the CCU-100 Camera Control Unit.

6. HP-3 Connections & Controls

The HP-3 headsets are designed for the cameraman to communicate with the director. The HP-3 should be connected to the 5-PIN XLR connector on the AD-2 (S/P/J). The Multi Transmission Adaptor Box (AD-2) then transmits audio signals to and from the ITC-100 Intercom System via the CCU-100 Camera Control Unit.

6.1 Features

- Reference quality, closed ear monitors
- High suppression of ambient noise
- Soft, circumaural ear pad
- Noise cancelling microphone
- Condenser omni-directional microphone capsule
- Very high gain-before-feedback
- Flexible gooseneck mic boom for optimal positioning
- Single exit, plug-in cable assembly





7. Frequently-Asked Questions

This section describes problems that you may encounter while using PTC-120. If you have questions, please refer to related sections and follow all the suggested solutions. If problem still exists, please contact your distributor or the service center.

No.	Problems	Solutions
1.	Is there a defined system boot order for the CCU or any special care that needs to be taken into account of?	<ol style="list-style-type: none">1. The recommended boot order is to turn on PD-6 first and then the rest of the devices.2. Please make sure the 4-PIN XLR power cable is the CCU proprietary cable, which is different from the general XLR power cable.3. It is recommended not to rewire the device while the power is connected; any change of the wiring should be done only after the power is disconnected.
2.	The AD-2 handset does not issue side tone sound.	Please purchase AD-2 device of Version GB717-SL-B or later.

8. Specifications

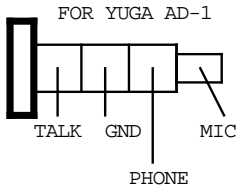
CCU-100 Main Unit Specifications		
Item	Parameter	Remarks
Camera Input	17 Pin Jack x 4	Connect to CB-43/44/45/49 All-in-One Cable (Signal transmission: HD-SDI, MCU Control, Power, Look Back, View Finder, Intercom, and Tally)
Video Input	Composite: BNC x 1	For Look Back CV Signal NTSC/PAL
Video Output	HD/SD-SDI: BNC x 4	HD-SDI: SMPTE 292M SD-SDI: SMPTE 259M
	Composite: BNC x 5	For View Finder Signal (QUAD CV Signal x 1/Single CV Signal x 4) NTSC/PAL
Control Port	RJ-45 x 4	Connect to MCU-200 for remote control
	XLR 5 Pin x 4	Connect to ITC-100 (Intercom/Tally Signal)
Indicator	Power LED x 1	CCU-100 Power Indicator (Power On: Red Color)
	Power LED x 4	Power Transmission Indicator (Power On: Red Color)
Power Transmission	XLR 4 Pin male x 4	Transmit 48V from PD-6 PIN1:GND PIN2:VCC PIN3/4:NC
Power Requirements	DC 12V	
Dimension	440 x 243.3 x 49mm	
AD-2 (S/P/J) Camera Adaptor Specifications		
Item	Parameter	Remarks
Camera Output	17 Pin Jack x 1	Connect to CB-43/44/45/49 All-in-One Cable (Signal transmission: HD-SDI, MCU Control, Power, Look Back, View Finder, Intercom, and Tally)
Video Input	HD/SD-SDI: BNC x 1	HD-SDI: SMPTE 292M SD-SDI: SMPTE 259M
MIC / Headset	XLR 5 Pin female x 1	PIN 1: MIC GND PIN 2: MIC PIN 3: EAR R/L PIN 4: NONE PIN 5: EAR GND

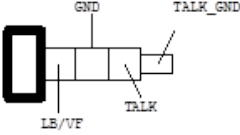
	3.5mm Jack x 1	Tip: MIC Ring1: Phone Ring2: GND Sleeve: Talk	
Signal Output	10 Pin Jack x 1 (SDI out, Tally, Power, Look Back, View Finder)	PIN1: Power ground (P_GND) PIN2: Signal ground (GND) PIN3: Control signal for switching between Look Back and View Finder images (SW-LB/VF) PIN4: Tally output (Green T_G) PIN5: Tally output (Red T_R) PIN6: CV image signal output (View Finder CV_VF) PIN7: CV image signal output (Look Back CV_LB) PIN8: Power output (OUT +8.4V/ 12V/ 16.8V, Max:1 A) PIN9: SDI output Signal PIN10: SDI output ground (GND)	Front View of the AD-2 Monitor Connector 
Control Port	3.5mm Jack x 1	Connect to RMC-240 (Talk button and Look Back / View Finder Switching)	
	Volume Control x 1		
	Camera Remote Control	SONY: 8 PIN Panasonic: 10 PIN JVC: 2.5 mm LANC Phone Jack / Multicore PS/2	
	Call Button x 1	Trigger audio transmission from headset 3.5mm jack back to ITC-100	
	External Tally Socket	Transmission of tally information from AD-2 (S/P/J) to SLD-1 SLED	
Indicator	Power LED x 1	Power Transmission Indicator 8.4V: Green Color 12V: Amber Color 16.8V: Red Color	
	Camera remote control link indicator	Link: Blue Color	
	Bi-Color Tally LED	LIVE Channel: Red Color CUED Channel: Green Color	
FW Upgrade	mini USB x 1		
Power Switch	Off/8.4V/12V/16.8V	Select power output level to camera	

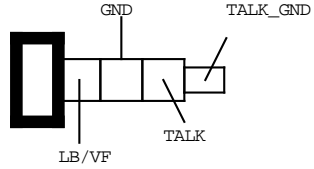
Power Output	Power to Camera (8.4V/12V/16.8V)	Power is generally fed from the V-mount battery pack. Total: Max 48W (Power to Monitor, Tally Light, Camera) (Condition: in 8.4V mode, the Max current is 4A)	
Dimension	175.5 x 126 x 85.2mm		
RMC-240 Remote Control Specifications			
Item	Parameter	Remarks	
Control Port	3.5mm Jack x 1	Connect to AD-2 (S/P) (Talk button and Look Back/View Finder Switching)	
Function Key	Talk Button x 1	Trigger audio transmission from headsets via XLR jack on AD-2 (S/P) back to ITC-100	
	Look Back Button x 1	Look Back/View Finder switching	
HP-3 Headset Specification			
Item	Parameter		
Headphone			
Transducer Principle	Dynamic		
Operating Principle	Closed		
Transmission Range	10Hz ~ 22 kHz		
Nominal Impedance	24 Ohms		
Nominal SPL at 1 kHz	96 dB		
T.H.D.	< 0.2 % (at 1KHz 1mW)		
Nominal Power Ratio	100 mW		
Microphone			
Transducer Principle	Condenser		
Transmission Range	20~16 kHz		
Polar Pattern	Omni-directional		
Nominal Impedance	2.2 KOhms		
Sensitivity	-6.4 dB		

Service & Support

It is our goal to make owning and using Datavideo products a satisfying experience. Our support staff is available to assist you to set up and operate your system. Contact your local office for specific support requests. Plus, please visit www.datavideo.com to access our FAQ section.

Datavideo Taiwan

Datavideo Technologies Co. Ltd
10F. No. 176, Jian 1st Rd., Chung Ho
District, New Taipei City 235, Taiwan,
R.O.C.
Tel: +886-2-8227-2888
Fax: +886-2-8227-2777
E-mail: service@datavideo.com.tw

Datavideo Europe

Datavideo Technologies Europe BV
Floridadreef 106
3565 AM Utrecht,
The Netherlands
Tel: +31-30-261-96-56
Fax: +31-30-261-96-57
E-mail: info@datavideo.nl

Datavideo United Kingdom

Datavideo UK Limited
Units 1 & 2 Waterside Business Park
Hadfield, Glossop, Derbyshire
SK13 1BE, UK
Tel: +44-1457 851 000
Fax: +44-1457 850 964
E-mail: sales@datavideo.co.uk

Datavideo USA

Datavideo Corporation
7048 Elmer Avenue.
Whittier, CA 90602,
U.S.A.
Tel: +1-562-696 2324
Fax: +1-562-698 6930
E-mail: sales@datavideo.us

Datavideo China

Datavideo Technologies China Co
101, NO. 618, LiuYing Rd, Zhabei District,
Shanghai, China
Tel: +86 21-5603 6599
Fax: +86 21-5603 6770
E-mail: service@datavideo.cn

Datavideo Singapore

Datavideo Technologies (S) PTE Ltd
No. 178 Paya Lebar Road #06-03
Singapore 409030
Tel: +65-6749 6866
Fax: +65-6749 3266
E-mail: sales@datavideo.sg

Datavideo Hong Kong

Datavideo Hong Kong Ltd
G/F., 26 Cross Lane
Wanchai, Hong Kong
Tel: +852-2833-1981
Fax: +852-2833-9916
E-mail: info@datavideo.com.hk

Datavideo France

Datavideo France s.a.r.l
Cité Descartes 1, rue Albert Einstein
Champs sur Marne
774477-Marne la Vallée cedex 2
Tel: +33-1-60370246
E-mail: info@datavideo.fr

Datavideo India

Datavideo Technologies India Pvt Ltd
A-132, Sec-63, Noida-201307,
Uttar Pradesh (UP), India.
Tel: +91-0120-2427337
Fax: +91-0120-2427338
E-mail: sales@datavideo.in



Please refer to our website for update the latest version manual.
<http://www.datavideo.com/Camera+Control/CCU-100>

datavideo
www.datavideo.com