

---

**S P E C F I L E**

---

Product Number : **PT-DZ870K/DZ870W**  
**PT-DZ870LK/DZ870LW**

Product Name : DLP™ Projectors

**Specifications**

**Main unit**

Power supply		120–240 V AC, 10–5.2 A, 50/60 Hz
Power consumption	120–240 V AC, 50/60 Hz	1,030 W (1,060 VA) (0.3 W with STANDBY MODE set to ECO*, 3 W with STANDBY MODE set to NORMAL)
DLP™ chip	Panel size	17.0 mm (0.67 in) diagonal (16:10 aspect ratio)
	Display method	DLP™ chip × 1, DLP™ system
	Pixels	2,304,000 (1,920 × 1,200) × 1, total of 2,304,000 pixels
Lens	PT-DZ870K/DZ870W	Powered zoom/focus lenses (1.7–2.4:1), F 1.7–1.9, f 25.6–35.7 mm
	PT-DZ870LK/DZ870LW	Optional powered zoom/focus lenses and fixed-focus lens
Lamp		420 W UHM lamps (× 2)
Screen size		1.27–15.24 m (50–600 inches)
		*1.27 – 5.08 m (50 – 200 inches) with the ET-DLE055 (16:10 aspect ratio)
		*2.54 – 8.89 m (100 – 350 inches) with the ET-DLE030 (16:10 aspect ratio)
Brightness*2		8,500 lumens (dual lamp, LAMP MODE: NORMAL)
Center-to-corner uniformity*2		90%
Contrast*2		10,000:1 (full on/full off, in dynamic iris 3 mode)
Resolution		1,920 × 1,200 pixels
Scanning frequency	SDI	3G-SDI signal (RGB 4:4:4 12-bit/10-bit): SMPTE ST 424 compliant: 1125(1080)/60i, 1125(1080)/50i, 1125(1080)/25p, 1125(1080)/24p, 1125(1080)/24sF, 1125(1080)/30p 3G-SDI signal (YPbPr 4:2:2 10-bit): SMPTE ST 424 compliant: 1125(1080)/60p, 1125(1080)/50p HD-SDI signal (YPbPr 4:2:2 10-bit): SMPTE ST 292 compliant: 750(720)/60p, 750(720)/50p, 1125(1035)/60i, 1125(1080)/60i, 1125(1080)/50i, 1125(1080)/25p, 1125(1080)/24p, 1125(1080)/24sF, 1125(1080)/30p SD-SDI signal (YCbCr 4:2:2 10-bit): SMPTE ST 259 compliant: 525i(480i), 625i(576i) fh: 15–100 kHz, fv: 24–120 Hz, dot clock: 25–162 MHz RGB fh: 15–100 kHz, fv: 24–120 Hz, dot clock: 162 MHz or lower YPbPr (YCbCr) 525i (480i): fh 15.75 kHz; fv 60 Hz, 625i (576i): fh 15.63 kHz; fv 50 Hz, 525p (480p): fh 31.50 kHz; fv 60 Hz, 625p (576p): fh 31.25 kHz; fv 50 Hz, 750 (720)/60p: fh 45.00 kHz; fv 60 Hz, 750 (720)/50p: fh 37.50 kHz; fv 50 Hz, 1125 (1035)/60i: fh 33.75 kHz; fv 60 Hz, 1125 (1080)/60i: fh 33.75 kHz; fv 60 Hz, 1125 (1080)/50i: fh 28.13 kHz; fv 50 Hz, 1125 (1080)/25p: fh 28.13 kHz; fv 25 Hz, 1125 (1080)/24p: fh 27.00 kHz; fv 24 Hz, 1125 (1080)/24sF: fh 27.00 kHz; fv 48 Hz, 1125 (1080)/30p: fh 33.75 kHz; fv 30 Hz, 1125 (1080)/60p: fh 67.50 kHz; fv 60 Hz, 1125 (1080)/50p: fh 56.25 kHz; fv 50 Hz
	HDMI/DVI-D	fh: 15–100 kHz, fv: 24–120 Hz, dot clock: 25–162 MHz
	RGB	fh: 15–100 kHz, fv: 24–120 Hz, dot clock: 162 MHz or lower
	YPbPr (YCbCr)	525i (480i): fh 15.75 kHz; fv 60 Hz, 625i (576i): fh 15.63 kHz; fv 50 Hz, 525p (480p): fh 31.50 kHz; fv 60 Hz, 625p (576p): fh 31.25 kHz; fv 50 Hz, 750 (720)/60p: fh 45.00 kHz; fv 60 Hz, 750 (720)/50p: fh 37.50 kHz; fv 50 Hz, 1125 (1035)/60i: fh 33.75 kHz; fv 60 Hz, 1125 (1080)/60i: fh 33.75 kHz; fv 60 Hz, 1125 (1080)/50i: fh 28.13 kHz; fv 50 Hz, 1125 (1080)/25p: fh 28.13 kHz; fv 25 Hz, 1125 (1080)/24p: fh 27.00 kHz; fv 24 Hz, 1125 (1080)/24sF: fh 27.00 kHz; fv 48 Hz, 1125 (1080)/30p: fh 33.75 kHz; fv 30 Hz, 1125 (1080)/60p: fh 67.50 kHz; fv 60 Hz, 1125 (1080)/50p: fh 56.25 kHz; fv 50 Hz
	Video/S-Video	fh: 15.75 kHz, fv: 60 Hz [NTSC/NTSC4.43/PAL-M/PAL60] fh: 15.63 kHz, fv: 50 Hz [PAL/PAL-N/SECAM]
Optical axis shift		Vertical: +50% (powered), horizontal: ±10% (powered) <b>NOTE: Optical axis shift function cannot be operated when used with the ET-DLE055.</b> If using the ET-DLE030, the optical axis is fixed.

Keystone correction range		<p>Vertical <math>\pm 40^\circ</math>                      (vertical <math>\pm 30^\circ</math> with the ET-DLE085/DLE055, vertical <math>+5^\circ</math> with the ET-DLE030)</p> <p>When using only the KEYSTONE correction of the Geometric Adjustment function: Vertical <math>\pm 40^\circ</math>, horizontal <math>\pm 15^\circ</math>                      (vertical <math>\pm 30^\circ</math> and horizontal <math>\pm 15^\circ</math> with the ET-DLE085/DLE055)</p> <p>When using the optional upgrade kit ET-UK20*3:                      Vertical <math>\pm 45^\circ</math> and horizontal <math>\pm 40^\circ</math>                      (vertical <math>\pm 22^\circ</math> and horizontal <math>\pm 15^\circ</math> with the ET-DLE085/DLE055, vertical <math>+5^\circ</math> with the ET-DLE030)</p> <p>When using both the KEYSTONE and CURVED corrections of the Geometric Adjustment function: Vertical <math>\pm 20^\circ</math>, horizontal <math>\pm 15^\circ</math>                      (vertical <math>\pm 8^\circ</math> and horizontal <math>\pm 8^\circ</math> with the ET-DLE085/DLE055)</p>
Installation		Ceiling/floor, front/rear
Terminals	SDI IN	<p>BNC <math>\times 1</math>,                      3G-SDI signal: SMPTE ST 424 compliant                      HD-SDI signal: SMPTE ST 292 compliant                      SD-SDI signal: SMPTE ST 259 compliant</p>
	HDMI IN	<p>HDMI 19-pin <math>\times 1</math>, Deep Color, compatible with HDCP,                      525i(480i)*4, 625i(576i)*4, 525p(480p), 625p(576p), 750(720)/60p,                      750(720)50p, 1125(1080)/60i, 1125(1080)/50i, 1125(1080)/25p,                      1125(1080)/24p, 1125(1080)/24sF, 1125(1080)/30p, 1125(1080)/60p,                      1125(1080)/50p                      VGA (640 <math>\times</math> 480)–WUXGA*5 (1,920 <math>\times</math> 1,200),                      dot clock: 25 MHz–162 MHz  <b>NOTE: Compatible with non-interlaced signals only.</b></p>
	DVI-D IN	<p>DVI-D 24-pin <math>\times 1</math>, DVI 1.0 compliant, HDCP compatible,                      for single link only                      525i(480i)*4, 625i(576i)*4, 525p(480p), 625p(576p), 750(720)/60p,                      750(720)50p, 1125(1080)/60i, 1125(1080)/50i, 1125(1080)/25p,                      1125(1080)/24p, 1125(1080)/24sF, 1125(1080)/30p, 1125(1080)/60p,                      1125(1080)/50p                      VGA (640 <math>\times</math> 480)–WUXGA*5 (1,920 <math>\times</math> 1,200),                      dot clock: 25 MHz–162 MHz  <b>NOTE: Compatible with non-interlaced signals only.</b></p>
	RGB 1 IN R, G, B	<p>BNC <math>\times 5</math>                      R: 0.7 Vp-p, 75 ohms,                      G: 0.7 Vp-p (G: 1.0 Vp-p for sync on G), 75 ohms,                      B: 0.7 Vp-p, 75 ohms                      HD, VD/SYNC: TTL, high impedance, positive/negative automatic  <b>NOTE: SYNC/HD and VD terminals do not accept tri-level sync signals.</b></p>
	Y, PB, PR (Y, CB, CR) S-Video signal	<p>Y: 1.0 Vp-p (including sync signal), PB/PR (CB/CR): 0.7 Vp-p, 75 ohms                      Y: 1.0 Vp-p, C: 0.286 Vp-p, 75 ohms</p>
	RGB 2 IN R, G, B	<p>D-sub HD 15-pin (female) <math>\times 1</math>                      R: 0.7 Vp-p, 75 ohms,                      G: 0.7 Vp-p (G: 1.0 Vp-p for sync on G), 75 ohms,                      B: 0.7 Vp-p, 75 ohms                      HD, VD/SYNC: TTL, high impedance, positive/negative automatic  <b>NOTE: SYNC/HD and VD terminals do not accept tri-level sync signals.</b></p>
	Y, PB, PR (Y, CB, CR) 3D SYNC 1 IN/OUT	<p>Y: 1.0 Vp-p (including sync signal), PB/PR (CB/CR): 0.7 Vp-p, 75 ohms                      BNC <math>\times 1</math>, 1.0 Vp-p, 75 ohms                      Input: TTL, high impedance. Output: TTL, max. 10 mA</p>
	3D SYNC 2 OUT	BNC $\times 1$ , 1.0 Vp-p, 75 ohms, TTL, max. 10 mA
	VIDEO IN	BNC $\times 1$ , 1.0 Vp-p, 75 ohms
	SERIAL IN	D-sub 9-pin (female) $\times 1$ for external control (RS-232C compliant)
	SERIAL OUT	D-sub 9-pin (male) $\times 1$ for link control (RS-232C compliant)
	REMOTE 1 IN	M3 jack $\times 1$ for wired remote control
	REMOTE 1 OUT	M3 jack $\times 1$ for link control
	REMOTE 2 IN	D-sub 9-pin (female) $\times 1$ for external control (parallel)

	LAN/DIGITAL LINK	RJ-45 × 1 for network and DIGITAL LINK (video/network/serial control) connection, 100Base-TX, compatible with Art-Net, compliant with PJLink™ (class 1), Deep Color, compatible with HDCP, 525i(480i)*4, 625i(576i)*4, 525p(480p), 625p(576p), 750(720)/60p, 750(720)50p, 1125(1080)/60i, 1125(1080)/50i, 1125(1080)/25p, 1125(1080)/24p, 1125(1080)/24sF, 1125(1080)/30p, 1125(1080)/60p, 1125(1080)/50p VGA (640 × 480)–WUXGA*4 (1,920 × 1,200), dot clock: 25 MHz–162 MHz <b>NOTE: Compatible with non-interlaced signals only.</b>
Power cord length		3.0 m (9 ft 10 in)
Cabinet materials		Molded plastic
Dimensions (W × H × D)	PT-DZ870K/DZ870W	498 × 200*6 × 556 mm (19-19/32 × 7-7/8*6 × 21-7/8 inches) (with supplied lens)
	PT-DZ870LK/DZ870LW	498 × 200*6 × 513 mm (19-19/32 × 7-7/8*6 × 20-3/16 inches) (without lens)
Weight*7	PT-DZ870K/DZ870W	Approx. 18.3 kg (40.3 lbs) (with supplied lens)
	PT-DZ870LK/DZ870LW	Approx. 17.6 kg (38.8 lbs) (without lens)
Operation noise*2		40 dB (dual lamp operation, LAMP MODE: NORMAL), 35 dB (dual lamp operation, LAMP MODE: ECO)
Operating temperature		0–45 °C (32–113 °F)*8
Operating humidity		10%–80% (no condensation)
<b>Remote control unit</b>		
Power supply		3 V DC (AAA type battery × 2)
Operation range*9		Approx. 30 m (98 ft 5 in) when operated from directly in front of the signal receptor
Dimensions (W × H × D)		48 × 145 × 27 mm (1-28/32 × 5-23/32 × 1-1/16 inches)
Weight		Approx. 102 g (3.6 oz) (including batteries)
<b>Supplied accessories</b>		
		Power cord (× 1) (× 2 for PT-DZ870EK/DZ870EW/DZ870ELK/DZ870ELW) Wireless/wired remote control unit (× 1) Batteries for remote control (AAA type × 2) Software CD-ROM (Logo Transfer Software, Multi Projector Monitoring & Control Software) (× 1)
<b>Optional accessories</b>		
Digital interface box		ET-YFB100G
Zoom lens (0.8–1.0:1)		ET-DLE085
Zoom lens (1.3–1.9:1)		ET-DLE150
Zoom lens (2.3–3.6:1)		ET-DLE250
Zoom lens (3.6–5.4:1)		ET-DLE350
Zoom lens (5.4–8.6:1)		ET-DLE450
Fixed-focus lens (0.4:1)		ET-DLE030
Fixed-focus lens (0.8:1)		ET-DLE055
Ceiling mount bracket		ET-PKD120H (for high ceilings) ET-PKD120S (for low ceilings) ET-PKD130H
High-ceiling mount bracket (6-axis adjustment mechanism)		
Attachment for ceiling mount bracket		ET-PKD130H/PKD120B
Upgrade kit		ET-UK20
Replacement lamp unit for portrait mode		ET-LAD120P ET-LAD120PW (Twin Pack)
Replacement lamp unit		ET-LAD120 ET-LAD120W (Twin Pack)

Weights and dimensions shown are approximate. Specifications and appearance are subject to change without notice.

- \*1 When the STANDBY MODE is set to ECO, network functions such as power on over the LAN network will not operate, and the serial output terminal cannot be used. Also, only certain commands can be received for external control using the serial terminal.
- \*2 Measurement, measuring conditions, and method of notation all comply with ISO 21118 international standards.
- \*3 Up to a total of ±55° during simultaneous horizontal and vertical correction.
- \*4 Only compatible with dot clock frequency of 27 MHz (pixel repetition signal)
- \*5 WUXGA resolution is supported only when the signals are compliant with VESA CVT-RB (Coordinated Video Timing-Reduced Blanking).
- \*6 With legs at shortest position.
- \*7 Average value. May differ depending on models.
- \*8 The operating temperature range is 0 °C to 40 °C (32 °F to 104 °F) when the fan control is set to High Altitude mode (for altitudes from 1,400 m to 2,700 m (4,593 ft to 8,858 ft) above sea level). Also, if the ambient temperature exceeds 40 °C (104 °F) (35 °C (95 °F) in High Altitude mode) when the projector is being used with Lamp Select set to Dual and Lamp Power set to High, the light output may be reduced approximately 20% to protect the projector.
- \*9 Operation range differs depending on environments.

Dimensions

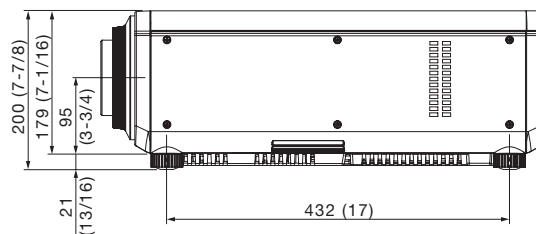
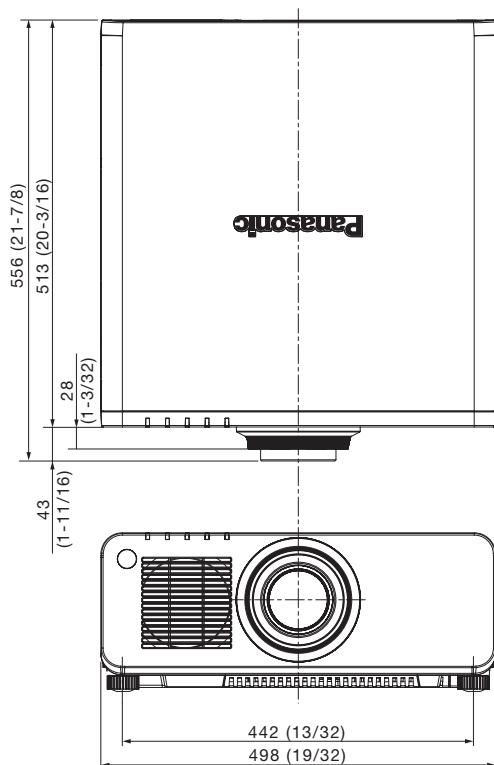

unit : mm (inch)  
 NOTE: This illustration is not drawn to scale.  
 The illustration shows the PT-DZ870K/DZ870W.

Terminals

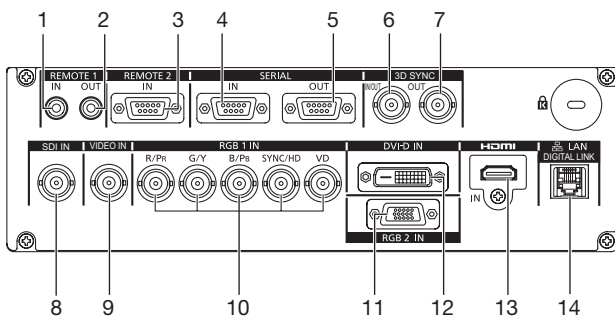

- 1 Remote 1 input
- 2 Remote 1 output
- 3 Remote 2 input
- 4 Serial input
- 5 Serial output
- 6 3D sync 1 input/output
- 7 3D sync 2 output
- 8 SDI input
- 9 Video input
- 10 RGB 1 input
- 11 RGB 2 Input
- 12 DVI-D input
- 13 HDMI input
- 14 LAN/DIGITAL LINK connector

Standard setting-up position (If using other than the ET-DLE030)

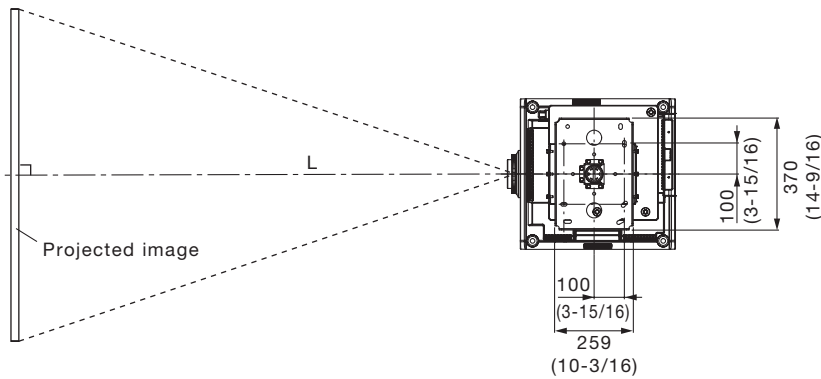
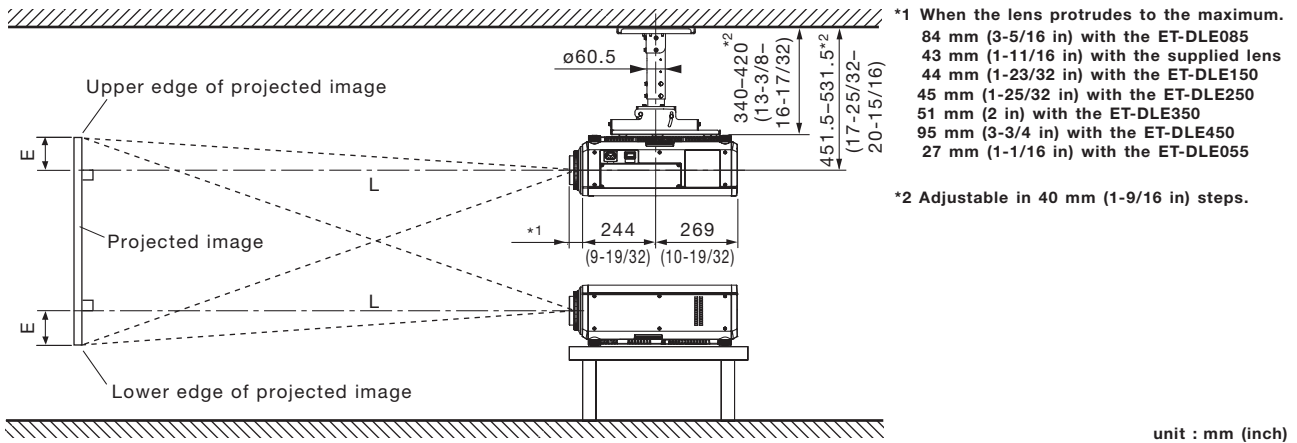

**Caution:**

- All construction work should be done by a qualified technician.
- When mounting to the ceiling, use the special mounting bracket. Furthermore, in order to prevent it from falling down from the ceiling, use the supplied wire on the mounting bracket.

Projection distance for 16:10 aspect ratio screen (If using other than the ET-DLE030)

**Unit: meters**

Screen size (diagonal)		Distance to screen (L)												Height from the edge of screen to center of lens (H)			
		Zoom											Fixed-focus				
		ET-DLE085 Zoom lens		ET-DLE150 Zoom lens		<i>Supplied lens</i>		ET-DLE250 Zoom lens		ET-DLE350 Zoom lens		ET-DLE450 Zoom lens				ET-DLE055 Fixed-focus lens	Zoom lenses
[m]	[in]	min.	max.	min.	max.	<i>min.</i>	<i>max.</i>	min.	max.	min.	max.	min.	max.				
1.27/	50	0.83	1.04	1.38	2.01	<b>1.82</b>	<b>2.57</b>	2.42	3.87	3.80	5.82	5.66	9.12	0.83	0.00	-0.34	0.34
1.52/	60	1.00	1.25	1.66	2.43	<b>2.20</b>	<b>3.10</b>	2.92	4.65	4.59	7.00	6.85	11.01	1.00	0.00	-0.40	0.40
1.78/	70	1.17	1.47	1.95	2.84	<b>2.58</b>	<b>3.63</b>	3.42	5.44	5.38	8.19	8.04	12.89	1.18	0.00	-0.47	0.47
2.03/	80	1.35	1.68	2.23	3.25	<b>2.95</b>	<b>4.16</b>	3.92	6.23	6.16	9.38	9.24	14.78	1.35	0.00	-0.54	0.54
2.29/	90	1.52	1.90	2.52	3.66	<b>3.33</b>	<b>4.69</b>	4.42	7.02	6.95	10.57	10.43	16.66	1.53	0.00	-0.61	0.61
2.54/	100	1.70	2.11	2.81	4.08	<b>3.71</b>	<b>5.21</b>	4.92	7.81	7.74	11.76	11.62	18.55	1.70	0.00	-0.67	0.67
3.05/	120	2.05	2.55	3.38	4.90	<b>4.47</b>	<b>6.27</b>	5.91	9.39	9.31	14.14	14.00	22.32	2.05	0.00	-0.81	0.81
3.81/	150	2.57	3.19	4.24	6.14	<b>5.61</b>	<b>7.86</b>	7.41	11.75	11.68	17.71	17.58	27.97	2.58	0.00	-1.01	1.01
5.08/	200	3.44	4.27	5.67	8.20	<b>7.50</b>	<b>10.50</b>	9.91	15.70	15.61	23.66	23.54	37.39	3.45	0.00	-1.35	1.35
6.35/	250	4.31	5.35	7.10	10.26	<b>9.39</b>	<b>13.15</b>	12.41	19.64	19.55	29.61	29.50	46.81	-	0.00	-1.68	-
7.62/	300	5.18	6.43	8.53	12.33	<b>11.28</b>	<b>15.79</b>	14.91	23.59	23.49	35.56	35.46	56.24	-	0.00	-2.02	-
10.16/	400	6.93	8.59	11.39	16.45	<b>15.07</b>	<b>21.08</b>	19.90	31.48	31.36	47.46	47.38	75.08	-	0.00	-2.69	-
12.70/	500	8.67	10.75	14.25	20.58	<b>18.86</b>	<b>26.36</b>	24.90	39.37	39.24	59.36	59.30	93.93	-	0.00	-3.37	-
15.24/	600	10.42	12.91	17.11	24.70	<b>22.64</b>	<b>31.65</b>	29.89	47.26	47.11	71.26	71.22	112.77	-	0.00	-4.04	-

**Unit: feet**

Screen size (diagonal)		Distance to screen (L)												Height from the edge of screen to center of lens (H)			
		Zoom											Fixed-focus				
		ET-DLE085 Zoom lens		ET-DLE150 Zoom lens		<i>Supplied lens</i>		ET-DLE250 Zoom lens		ET-DLE350 Zoom lens		ET-DLE450 Zoom lens				ET-DLE055 Fixed-focus lens	Zoom lenses
[m]	[in]	min.	max.	min.	max.	<i>min.</i>	<i>max.</i>	min.	max.	min.	max.	min.	max.				
1.27/	50	2.7	3.4	4.5	6.6	<b>6.0</b>	<b>8.4</b>	7.9	12.7	12.5	19.1	18.6	29.9	2.7	0.0	- 1.1	1.1
1.52/	60	3.3	4.1	5.5	8.0	<b>7.2</b>	<b>10.2</b>	9.6	15.3	15.1	23.0	22.5	36.1	3.3	0.0	- 1.3	1.3
1.78/	70	3.9	4.8	6.4	9.3	<b>8.5</b>	<b>11.9</b>	11.2	17.9	17.6	26.9	26.4	42.3	3.9	0.0	- 1.6	1.6
2.03/	80	4.4	5.5	7.3	10.7	<b>9.7</b>	<b>13.6</b>	12.8	20.4	20.2	30.8	30.3	48.5	4.4	0.0	- 1.8	1.8
2.29/	90	5.0	6.2	8.3	12.0	<b>10.9</b>	<b>15.4</b>	14.5	23.0	22.8	34.7	34.2	54.7	5.0	0.0	- 2.0	2.0
2.54/	100	5.6	6.9	9.2	13.4	<b>12.2</b>	<b>17.1</b>	16.1	25.6	25.4	38.6	38.1	60.8	5.6	0.0	- 2.2	2.2
3.05/	120	6.7	8.4	11.1	16.1	<b>14.7</b>	<b>20.6</b>	19.4	30.8	30.6	46.4	45.9	73.2	6.7	0.0	- 2.7	2.7
3.81/	150	8.4	10.5	13.9	20.1	<b>18.4</b>	<b>25.8</b>	24.3	38.6	38.3	58.1	57.7	91.8	8.5	0.0	- 3.3	3.3
5.08/	200	11.3	14.0	18.6	26.9	<b>24.6</b>	<b>34.5</b>	32.5	51.5	51.2	77.6	77.2	122.7	11.3	0.0	- 4.4	4.4
6.35/	250	14.1	17.6	23.3	33.7	<b>30.8</b>	<b>43.1</b>	40.7	64.4	64.1	97.1	96.8	153.6	-	0.0	- 5.5	-
7.62/	300	17.0	21.1	28.0	40.4	<b>37.0</b>	<b>51.8</b>	48.9	77.4	77.1	116.7	116.3	184.5	-	0.0	- 6.6	-
10.16/	400	22.7	28.2	37.4	54.0	<b>49.4</b>	<b>69.1</b>	65.3	103.3	102.9	155.7	155.4	246.3	-	0.0	- 8.8	-
12.70/	500	28.5	35.3	46.7	67.5	<b>61.9</b>	<b>86.5</b>	81.7	129.2	128.7	194.7	194.6	308.2	-	0.0	-11.0	-
15.24/	600	34.2	42.3	56.1	81.0	<b>74.3</b>	<b>103.8</b>	98.1	155.0	154.6	233.8	233.7	370.0	-	0.0	-13.3	-

- The value for L (distance to screen) varies slightly within ±5% depending on the zoom lens characteristics.
- The zoom lens characteristics may cause slight image distortion.
- When vertical keystone correction is used, the image is corrected in the direction that reduces its projected size.
- The brightness varies depending on the zoom setting.

Note: When the ET-DLE055 is mounted, the optical lens shift function cannot be used.

Projection distance for 16:9 aspect ratio screen (If using other than the ET-DLE030)

**Unit: meters**

Screen size (diagonal)		Distance to screen (L)												Height from the edge of screen to center of lens (H)			
		Zoom											Fixed-focus				
		ET-DLE085 Zoom lens		ET-DLE150 Zoom lens		<i>Supplied lens</i>		ET-DLE250 Zoom lens		ET-DLE350 Zoom lens		ET-DLE450 Zoom lens				ET-DLE055 Fixed-focus lens	
[m]	[in]	min.	max.	min.	max.	<i>min.</i>	<i>max.</i>	min.	max.	min.	max.	min.	max.		Zoom lenses	Fixed- focus lens	
1.27/	50	0.85	1.07	1.42	2.07	<b>1.87</b>	<b>2.64</b>	2.49	3.98	3.91	5.98	5.82	9.39	0.85	-0.06	-0.31	0.31
1.52/	60	1.03	1.29	1.71	2.49	<b>2.26</b>	<b>3.19</b>	3.00	4.79	4.72	7.20	7.05	11.32	1.03	-0.08	-0.37	0.37
1.78/	70	1.21	1.51	2.00	2.92	<b>2.65</b>	<b>3.73</b>	3.51	5.60	5.53	8.43	8.28	13.26	1.21	-0.09	-0.44	0.44
2.03/	80	1.39	1.73	2.30	3.34	<b>3.04</b>	<b>4.28</b>	4.03	6.41	6.34	9.65	9.50	15.20	1.39	-0.10	-0.50	0.50
2.29/	90	1.57	1.95	2.59	3.77	<b>3.43</b>	<b>4.82</b>	4.54	7.22	7.15	10.87	10.73	17.13	1.57	-0.11	-0.56	0.56
2.54/	100	1.75	2.17	2.89	4.19	<b>3.82</b>	<b>5.36</b>	5.05	8.03	7.96	12.09	11.95	19.07	1.75	-0.13	-0.62	0.62
3.05/	120	2.10	2.62	3.47	5.04	<b>4.60</b>	<b>6.45</b>	6.08	9.65	9.58	14.54	14.40	22.94	2.11	-0.15	-0.75	0.75
3.81/	150	2.64	3.28	4.36	6.31	<b>5.76</b>	<b>8.08</b>	7.62	12.08	12.00	18.21	18.08	28.75	2.65	-0.19	-0.93	0.93
5.08/	200	3.54	4.39	5.83	8.43	<b>7.71</b>	<b>10.80</b>	10.19	16.14	16.05	24.32	24.20	38.44	3.55	-0.25	-1.25	1.25
6.35/	250	4.43	5.50	7.29	10.55	<b>9.65</b>	<b>13.51</b>	12.76	20.19	20.10	30.44	30.33	48.12	-	-0.31	-1.56	-
7.62/	300	5.33	6.61	8.76	12.67	<b>11.60</b>	<b>16.23</b>	15.32	24.25	24.14	36.55	36.45	57.81	-	-0.37	-1.87	-
10.16/	400	7.12	8.83	11.70	16.91	<b>15.49</b>	<b>21.66</b>	20.46	32.35	32.24	48.78	48.71	77.18	-	-0.50	-2.49	-
12.70/	500	8.91	11.05	14.64	21.15	<b>19.38</b>	<b>27.10</b>	25.59	40.46	40.33	61.01	60.96	96.55	-	-0.62	-3.11	-
15.24/	600	10.71	13.27	17.58	25.39	<b>23.27</b>	<b>32.53</b>	30.72	48.57	48.42	73.24	73.21	115.92	-	-0.75	-3.74	-

**Unit: feet**

Screen size (diagonal)		Distance to screen (L)												Height from the edge of screen to center of lens (H)			
		Zoom											Fixed-focus				
		ET-DLE085 Zoom lens		ET-DLE150 Zoom lens		<i>Supplied lens</i>		ET-DLE250 Zoom lens		ET-DLE350 Zoom lens		ET-DLE450 Zoom lens				ET-DLE055 Fixed-focus lens	
[m]	[in]	min.	max.	min.	max.	<i>min.</i>	<i>max.</i>	min.	max.	min.	max.	min.	max.		Zoom lenses	Fixed- focus lens	
1.27/	50	2.8	3.5	4.6	6.8	<b>6.1</b>	<b>8.7</b>	8.2	13.0	12.8	19.6	19.1	30.8	2.8	-0.2	- 1.0	1.0
1.52/	60	3.4	4.2	5.6	8.2	<b>7.4</b>	<b>10.5</b>	9.8	15.7	15.5	23.6	23.1	37.1	3.4	-0.3	- 1.2	1.2
1.78/	70	4.0	5.0	6.6	9.6	<b>8.7</b>	<b>12.2</b>	11.5	18.4	18.1	27.6	27.1	43.5	4.0	-0.3	- 1.4	1.4
2.03/	80	4.6	5.7	7.5	11.0	<b>10.0</b>	<b>14.0</b>	13.2	21.0	20.8	31.7	31.2	49.9	4.6	-0.3	- 1.6	1.6
2.29/	90	5.1	6.4	8.5	12.4	<b>11.2</b>	<b>15.8</b>	14.9	23.7	23.5	35.7	35.2	56.2	5.2	-0.4	- 1.8	1.8
2.54/	100	5.7	7.1	9.5	13.8	<b>12.5</b>	<b>17.6</b>	16.6	26.3	26.1	39.7	39.2	62.6	5.7	-0.4	- 2.0	2.0
3.05/	120	6.9	8.6	11.4	16.5	<b>15.1</b>	<b>21.2</b>	20.0	31.7	31.4	47.7	47.2	75.3	6.9	-0.5	- 2.5	2.5
3.81/	150	8.7	10.8	14.3	20.7	<b>18.9</b>	<b>26.5</b>	25.0	39.6	39.4	59.7	59.3	94.3	8.7	-0.6	- 3.1	3.1
5.08/	200	11.6	14.4	19.1	27.7	<b>25.3</b>	<b>35.4</b>	33.4	52.9	52.7	79.8	79.4	126.1	11.7	-0.8	- 4.1	4.1
6.35/	250	14.5	18.1	23.9	34.6	<b>31.7</b>	<b>44.3</b>	41.8	66.2	65.9	99.9	99.5	157.9	-	-1.0	- 5.1	-
7.62/	300	17.5	21.7	28.8	41.6	<b>38.1</b>	<b>53.2</b>	50.3	79.5	79.2	119.9	119.6	189.7	-	-1.2	- 6.1	-
10.16/	400	23.4	29.0	38.4	55.5	<b>50.8</b>	<b>71.1</b>	67.1	106.1	105.8	160.0	159.8	253.2	-	-1.6	- 8.2	-
12.70/	500	29.2	36.3	48.0	69.4	<b>63.6</b>	<b>88.9</b>	84.0	132.7	132.3	200.2	200.0	316.8	-	-2.0	-10.2	-
15.24/	600	35.1	43.5	57.7	83.3	<b>76.4</b>	<b>106.7</b>	100.8	159.4	158.9	240.3	240.2	380.3	-	-2.5	-12.3	-

- The value for L (distance to screen) varies slightly within ±5% depending on the zoom lens characteristics.
- The zoom lens characteristics may cause slight image distortion.
- When vertical keystone correction is used, the image is corrected in the direction that reduces its projected size.
- The brightness varies depending on the zoom setting.

Note: When the ET-DLE055 is mounted, the optical lens shift function cannot be used.



Projection distance for 4:3 aspect ratio screen (If using other than the ET-DLE030)

**Unit: meters**

Screen size (diagonal)		Distance to screen (L)												Height from the edge of screen to center of lens (H)		
		Zoom										Fixed-focus				
		ET-DLE085 Zoom lens		ET-DLE150 Zoom lens		<i>Supplied lens</i>		ET-DLE250 Zoom lens		ET-DLE350 Zoom lens		ET-DLE450 Zoom lens				ET-DLE055 Fixed-focus lens
[m]	[in]	min.	max.	min.	max.	<i>min.</i>	<i>max.</i>	min.	max.	min.	max.	min.	max.			
1.27/ 50	0.94	1.18	1.57	2.29	<b>2.07</b>	<b>2.92</b>	2.75	4.39	4.32	6.60	6.45	10.37	0.94	0.00	-0.38	0.38
1.52/ 60	1.14	1.42	1.89	2.75	<b>2.50</b>	<b>3.52</b>	3.31	5.28	5.21	7.95	7.80	12.50	1.14	0.00	-0.46	0.46
1.78/ 70	1.34	1.67	2.21	3.22	<b>2.93</b>	<b>4.12</b>	3.88	6.17	6.11	9.29	9.15	14.64	1.34	0.00	-0.53	0.53
2.03/ 80	1.53	1.91	2.54	3.69	<b>3.35</b>	<b>4.72</b>	4.44	7.07	7.00	10.64	10.49	16.77	1.54	0.00	-0.61	0.61
2.29/ 90	1.73	2.16	2.86	4.15	<b>3.78</b>	<b>5.31</b>	5.01	7.96	7.89	11.99	11.84	18.90	1.74	0.00	-0.69	0.69
2.54/ 100	1.93	2.40	3.18	4.62	<b>4.21</b>	<b>5.91</b>	5.58	8.85	8.78	13.34	13.19	21.04	1.93	0.00	-0.76	0.76
3.05/ 120	2.32	2.89	3.83	5.56	<b>5.07</b>	<b>7.11</b>	6.71	10.64	10.56	16.03	15.89	25.30	2.33	0.00	-0.91	0.91
3.81/ 150	2.91	3.62	4.80	6.96	<b>6.36</b>	<b>8.91</b>	8.40	13.32	13.24	20.07	19.94	31.70	2.93	0.00	-1.14	1.14
5.08/ 200	3.90	4.84	6.42	9.29	<b>8.50</b>	<b>11.90</b>	11.23	17.78	17.69	26.81	26.69	42.37	3.92	0.00	-1.52	1.52
6.35/ 250	4.89	6.07	8.04	11.63	<b>10.64</b>	<b>14.89</b>	14.06	22.25	22.15	33.54	33.44	53.04	-	0.00	-1.91	-
7.62/ 300	5.88	7.29	9.66	13.96	<b>12.78</b>	<b>17.88</b>	16.88	26.71	26.61	40.28	40.18	63.70	-	0.00	-2.29	-
10.16/ 400	7.85	9.73	12.90	18.63	<b>17.07</b>	<b>23.87</b>	22.54	35.65	35.52	53.74	53.68	85.04	-	0.00	-3.05	-
12.70/ 500	9.82	12.17	16.13	23.30	<b>21.36</b>	<b>29.85</b>	28.19	44.58	44.44	67.21	67.17	106.37	-	0.00	-3.81	-
15.24/ 600	11.80	14.62	19.37	27.97	<b>25.64</b>	<b>35.84</b>	33.85	53.51	53.35	80.68	80.67	127.71	-	0.00	-4.57	-

**Unit: feet**

Screen size (diagonal)		Distance to screen (L)												Height from the edge of screen to center of lens (H)		
		Zoom										Fixed-focus				
		ET-DLE085 Zoom lens		ET-DLE150 Zoom lens		<i>Supplied lens</i>		ET-DLE250 Zoom lens		ET-DLE350 Zoom lens		ET-DLE450 Zoom lens				ET-DLE055 Fixed-focus lens
[m]	[in]	min.	max.	min.	max.	<i>min.</i>	<i>max.</i>	min.	max.	min.	max.	min.	max.			
1.27/ 50	3.1	3.9	5.1	7.5	<b>6.8</b>	<b>9.6</b>	9.0	14.4	14.2	21.7	21.1	34.0	3.1	0.0	- 1.3	1.3
1.52/ 60	3.7	4.7	6.2	9.0	<b>8.2</b>	<b>11.5</b>	10.9	17.3	17.1	26.1	25.6	41.0	3.7	0.0	- 1.5	1.5
1.78/ 70	4.4	5.5	7.3	10.6	<b>9.6</b>	<b>13.5</b>	12.7	20.3	20.0	30.5	30.0	48.0	4.4	0.0	- 1.8	1.8
2.03/ 80	5.0	6.3	8.3	12.1	<b>11.0</b>	<b>15.5</b>	14.6	23.2	23.0	34.9	34.4	55.0	5.0	0.0	- 2.0	2.0
2.29/ 90	5.7	7.1	9.4	13.6	<b>12.4</b>	<b>17.4</b>	16.4	26.1	25.9	39.3	38.9	62.0	5.7	0.0	- 2.3	2.3
2.54/ 100	6.3	7.9	10.4	15.2	<b>13.8</b>	<b>19.4</b>	18.3	29.0	28.8	43.8	43.3	69.0	6.3	0.0	- 2.5	2.5
3.05/ 120	7.6	9.5	12.6	18.2	<b>16.6</b>	<b>23.3</b>	22.0	34.9	34.7	52.6	52.1	83.0	7.6	0.0	- 3.0	3.0
3.81/ 150	9.6	11.9	15.8	22.8	<b>20.8</b>	<b>29.2</b>	27.6	43.7	43.4	65.8	65.4	104.0	9.6	0.0	- 3.8	3.8
5.08/ 200	12.8	15.9	21.1	30.5	<b>27.9</b>	<b>39.0</b>	36.8	58.3	58.0	87.9	87.6	139.0	12.8	0.0	- 5.0	5.0
6.35/ 250	16.0	19.9	26.4	38.1	<b>34.9</b>	<b>48.9</b>	46.1	73.0	72.7	110.0	109.7	174.0	-	0.0	- 6.3	-
7.62/ 300	19.3	23.9	31.7	45.8	<b>41.9</b>	<b>58.7</b>	55.4	87.6	87.3	132.1	131.8	209.0	-	0.0	- 7.5	-
10.16/ 400	25.8	31.9	42.3	61.1	<b>56.0</b>	<b>78.3</b>	73.9	116.9	116.5	176.3	176.1	279.0	-	0.0	-10.0	-
12.70/ 500	32.2	39.9	52.9	76.5	<b>70.1</b>	<b>97.9</b>	92.5	146.2	145.8	220.5	220.4	349.0	-	0.0	-12.5	-
15.24/ 600	38.7	48.0	63.6	91.8	<b>84.1</b>	<b>117.6</b>	111.0	175.5	175.0	264.7	264.7	419.0	-	0.0	-15.0	-

- The value for L (distance to screen) varies slightly within ±5% depending on the zoom lens characteristics.
- The zoom lens characteristics may cause slight image distortion.
- When vertical keystone correction is used, the image is corrected in the direction that reduces its projected size.
- The brightness varies depending on the zoom setting.

Note: When the ET-DLE055 is mounted, the optical lens shift function cannot be used.

Standard setting-up position (If using the ET-DLE030)

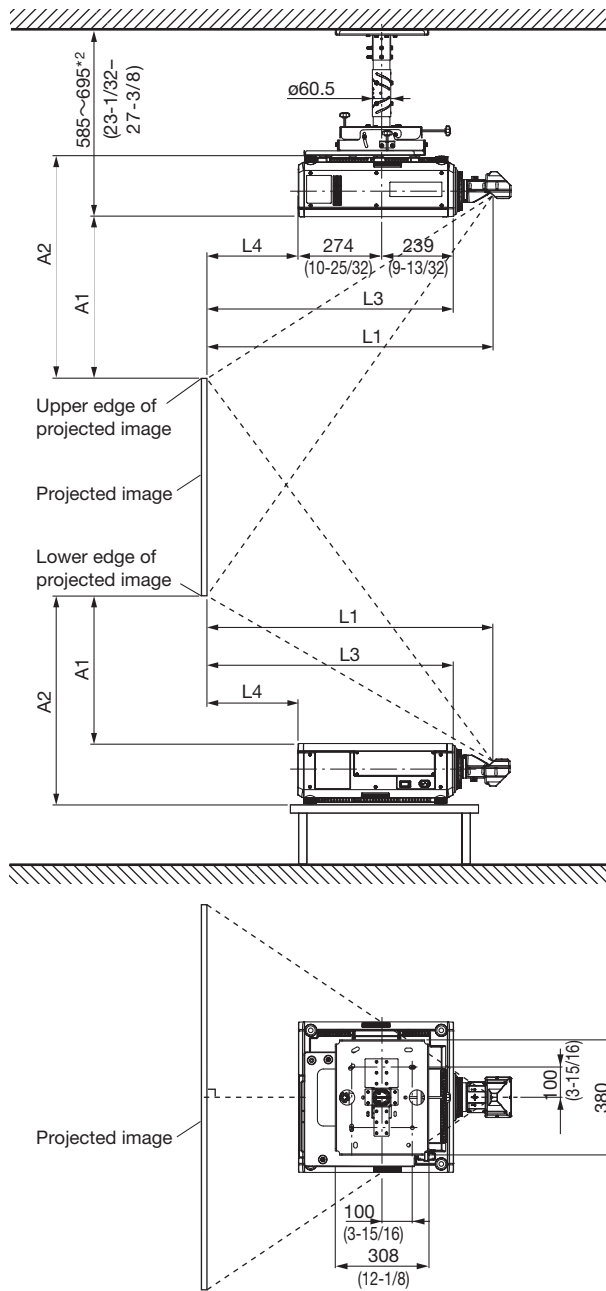

- \*1 When the lens protrudes to the maximum.
  - 84 mm (3-5/16 in) with the ET-DLE085
  - 43 mm (1-11/16 in) with the supplied lens
  - 44 mm (1-23/32 in) with the ET-DLE150
  - 45 mm (1-25/32 in) with the ET-DLE250
  - 51 mm (2 in) with the ET-DLE350
  - 95 mm (3-3/4 in) with the ET-DLE450
  - 27 mm (1-1/16 in) with the ET-DLE055

\*2 Adjustable in 40 mm (1-9/16 in) steps.

unit : mm (inch)

NOTE:

Illustrations show the projector installed using optional ceiling mount bracket ET-PKD130H, optional bracket assembly ET-PKD130B and an optional lens. This illustration is not drawn to scale.

**Caution:**

- All construction work should be done by a qualified technician.
- When mounting to the ceiling, use the special mounting bracket. Furthermore, in order to prevent it from falling down from the ceiling, use the supplied wire on the mounting bracket.

**Projection distance for 16:10 aspect ratio screen (If using the ET-DLE030)**

Unit : meters

Ultra-short focal length lens ET-DLE030 Close-up system dimensions									
Throw ratio				0.38:1	(0.39:1)				
Diagonal image size (Inches)	Diagonal image size (m)	Height (SH)	Width (SW)	Projection distance (From mirror reflective surface to screen) (L1)	From tip of lens to screen (L2)	From front of set to screen (L3)	From rear of set to screen (L4)	From top of set to bottom edge of screen (A1)	From bottom of set to bottom edge of screen (A2)
100	2.54	1.35	2.15	0.82	0.84	0.65	0.14	0.43	0.63
120	3.05	1.62	2.59	0.98	1.00	0.82	0.30	0.53	0.73
150	3.81	2.02	3.23	1.23	1.25	1.06	0.55	0.68	0.88
200	5.08	2.69	4.31	1.63	1.66	1.47	0.95	0.93	1.13
250	6.35	3.37	5.39	2.04	2.06	1.87	1.36	1.18	1.38
300	7.62	4.04	6.46	2.45	2.47	2.28	1.77	1.43	1.63
350	8.89	4.71	7.54	2.85	2.88	2.69	2.18	1.69	1.89

Unit : feet

Ultra-short focal length lens ET-DLE030 Close-up system dimensions									
Throw ratio				0.38:1	(0.39:1)				
Diagonal image size (Inches)	Diagonal image size (m)	Height (SH)	Width (SW)	Projection distance (From mirror reflective surface to screen) (L1)	From tip of lens to screen (L2)	From front of set to screen (L3)	From rear of set to screen (L4)	From top of set to bottom edge of screen (A1)	From bottom of set to bottom edge of screen (A2)
100	2.54	4.4	7.1	2.7	2.8	2.1	0.5	1.4	2.1
120	3.05	5.3	8.5	3.2	3.3	2.7	1.0	1.7	2.4
150	3.81	6.6	10.6	4.0	4.1	3.5	1.8	2.2	2.9
200	5.08	8.8	14.1	5.4	5.4	4.8	3.1	3.1	3.7
250	6.35	11.0	17.7	6.7	6.8	6.1	4.5	3.9	4.5
300	7.62	13.3	21.2	8.0	8.1	7.5	5.8	4.7	5.4
350	8.89	15.5	24.7	9.4	9.4	8.8	7.1	5.5	6.2

- \* The value for L1 may contain an error of within ±5%.
- \* When using vertical keystone correction, the images will be corrected so that they will tend to be smaller than the specified screen size.
- \* This measurement is not the distance between the rear of the projector and the wall, but is instead the distance between the rear of the projector and the screen surface. Leave at least 500 mm of space between the rear of the projector and the wall and any other objects in order to provide adequate ventilation space. If setting up the projector in a closed room, be sure to provide separate air conditioning and ventilation equipment. If there is insufficient ventilation in the room, radiated heat may build up and cause the protection circuit of the projector to operate.

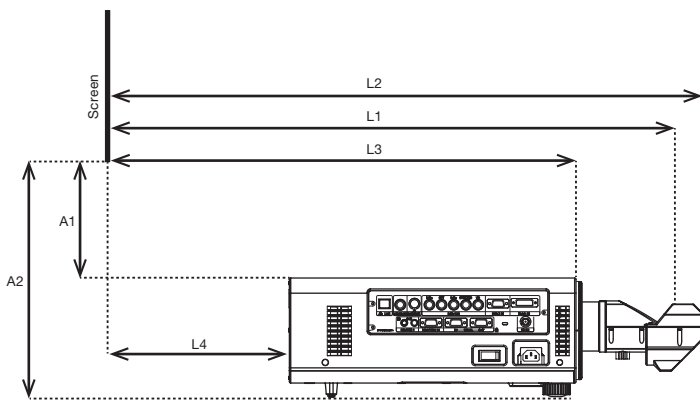

- L1: Projection distance (from screen to mirror reflective surface)
- L2: From screen to tip of lens
- L3: From screen to front of set
- L4: From screen to rear of set
- A1: From bottom edge of screen to top of set
- A2: From bottom edge of screen to bottom of set

**Projection Distance Calculation Table**

**Screen aspect ratio 16:10**

Projection distance calculation formula

$$L1 \text{ (m)} = 0.3205 \times \text{Diagonal image size} + 0.0047$$

Calculation formula for distance from top of set to bottom edge of screen

$$A1 \text{ (m)} = 0.1977 \times \text{Diagonal image size} - 0.07210$$

**Projection distance for 16:9 aspect ratio screen (If using the ET-DLE030)**

Unit : meters

Ultra-short focal length lens ET-DLE030 Close-up system dimensions									
Throw ratio				0.38:1	(0.4:1)				
Diagonal image size (Inches)	Diagonal image size (m)	Height (SH)	Width (SW)	Projection distance (From mirror reflective surface to screen) (L1)	From tip of lens to screen (L2)	From front of set to screen (L3)	From rear of set to screen (L4)	From top of set to bottom edge of screen (A1)	From bottom of set to bottom edge of screen (A2)
100	2.54	1.25	2.21	0.84	0.86	0.68	0.16	0.51	0.71
120	3.05	1.49	2.66	1.01	1.03	0.84	0.33	0.63	0.83
150	3.81	1.87	3.32	1.26	1.28	1.09	0.58	0.81	1.01
200	5.08	2.49	4.43	1.68	1.70	1.51	1.00	1.10	1.30
250	6.35	3.11	5.54	2.10	2.12	1.93	1.42	1.39	1.59
300	7.62	3.74	6.64	2.52	2.54	2.35	1.84	1.68	1.88
350	8.89	4.36	7.75	2.93	2.95	2.77	2.25	1.98	2.18

Unit : feet

Ultra-short focal length lens ET-DLE030 Close-up system dimensions									
Throw ratio				0.38:1	(0.4:1)				
Diagonal image size (Inches)	Diagonal image size (m)	Height (SH)	Width (SW)	Projection distance (From mirror reflective surface to screen) (L1)	From tip of lens to screen (L2)	From front of set to screen (L3)	From rear of set to screen (L4)	From top of set to bottom edge of screen (A1)	From bottom of set to bottom edge of screen (A2)
100	2.54	4.1	7.3	2.8	2.8	2.2	0.5	1.7	2.3
120	3.05	4.9	8.7	3.3	3.4	2.8	1.1	2.1	2.7
150	3.81	6.1	10.9	4.1	4.2	3.6	1.9	2.6	3.3
200	5.08	8.2	14.5	5.5	5.6	5.0	3.3	3.6	4.3
250	6.35	10.2	18.2	6.9	7.0	6.3	4.6	4.6	5.2
300	7.62	12.3	21.8	8.3	8.3	7.7	6.0	5.5	6.2
350	8.89	14.3	25.4	9.6	9.7	9.1	7.4	6.5	7.1

- \* The value for L1 may contain an error of within ±5%.
- \* When using vertical keystone correction, the images will be corrected so that they will tend to be smaller than the specified screen size.
- \* This measurement is not the distance between the rear of the projector and the wall, but is instead the distance between the rear of the projector and the screen surface. Leave at least 500 mm of space between the rear of the projector and the wall and any other objects in order to provide adequate ventilation space. If setting up the projector in a closed room, be sure to provide separate air conditioning and ventilation equipment. If there is insufficient ventilation in the room, radiated heat may build up and cause the protection circuit of the projector to operate.

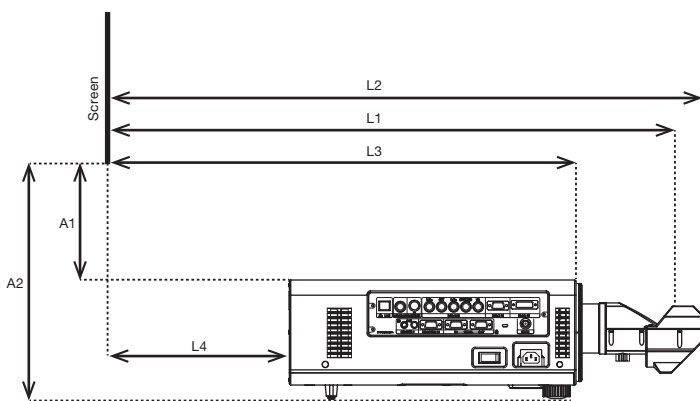

- L1: Projection distance (from screen to mirror reflective surface)
- L2: From screen to tip of lens
- L3: From screen to front of set
- L4: From screen to rear of set
- A1: From bottom edge of screen to top of set
- A2: From bottom edge of screen to bottom of set

**Projection Distance Calculation Table**

**Screen aspect ratio 16:9**

Projection distance calculation formula

$$L1 (m) = 0.3294 \times \text{Diagonal image size} + 0.0047$$

Calculation formula for distance from top of set to bottom edge of screen

$$A1 (m) = 0.2304 \times \text{Diagonal image size} - 0.07210$$

Projection distance for 4:3 aspect ratio screen (If using the ET-DLE030)

Unit : meters

Ultra-short focal length lens ET-DLE030 Close-up system dimensions									
Throw ratio				0.38:1	(0.46:1)				
Diagonal image size (Inches)	Diagonal image size (m)	Height (SH)	Width (SW)	Projection distance (From mirror reflective surface to screen) (L1)	From tip of lens to screen (L2)	From front of set to screen (L3)	From rear of set to screen (L4)	From top of set to bottom edge of screen (A1)	From bottom of set to bottom edge of screen (A2)
100	2.54	1.52	2.03	0.93	0.95	0.76	0.25	0.50	0.70
120	3.05	1.83	2.44	1.11	1.13	0.94	0.43	0.61	0.81
150	3.81	2.29	3.05	1.39	1.41	1.22	0.71	0.78	0.98
200	5.08	3.05	4.06	1.85	1.87	1.68	1.17	1.07	1.27
250	6.35	3.81	5.08	2.31	2.33	2.14	1.63	1.35	1.55
300	7.62	4.57	6.10	2.77	2.79	2.60	2.09	1.63	1.83
350	8.89	5.33	7.11	3.23	3.25	3.06	2.55	1.92	2.12

Unit : feet

Ultra-short focal length lens ET-DLE030 Close-up system dimensions									
Throw ratio				0.38:1	(0.46:1)				
Diagonal image size (Inches)	Diagonal image size (m)	Height (SH)	Width (SW)	Projection distance (From mirror reflective surface to screen) (L1)	From tip of lens to screen (L2)	From front of set to screen (L3)	From rear of set to screen (L4)	From top of set to bottom edge of screen (A1)	From bottom of set to bottom edge of screen (A2)
100	2.54	5.0	6.7	3.0	3.1	2.5	0.8	1.6	2.3
120	3.05	6.0	8.0	3.6	3.7	3.1	1.4	2.0	2.7
150	3.81	7.5	10.0	4.6	4.6	4.0	2.3	2.6	3.2
200	5.08	10.0	13.3	6.1	6.1	5.5	3.8	3.5	4.2
250	6.35	12.5	16.7	7.6	7.6	7.0	5.3	4.4	5.1
300	7.62	15.0	20.0	9.1	9.2	8.5	6.9	5.4	6.0
350	8.89	17.5	23.3	10.6	10.7	10.1	8.4	6.3	6.9

- \* The value for L1 may contain an error of within ±5%.
- \* When using vertical keystone correction, the images will be corrected so that they will tend to be smaller than the specified screen size.
- \* This measurement is not the distance between the rear of the projector and the wall, but is instead the distance between the rear of the projector and the screen surface. Leave at least 500 mm of space between the rear of the projector and the wall and any other objects in order to provide adequate ventilation space. If setting up the projector in a closed room, be sure to provide separate air conditioning and ventilation equipment. If there is insufficient ventilation in the room, radiated heat may build up and cause the protection circuit of the projector to operate.

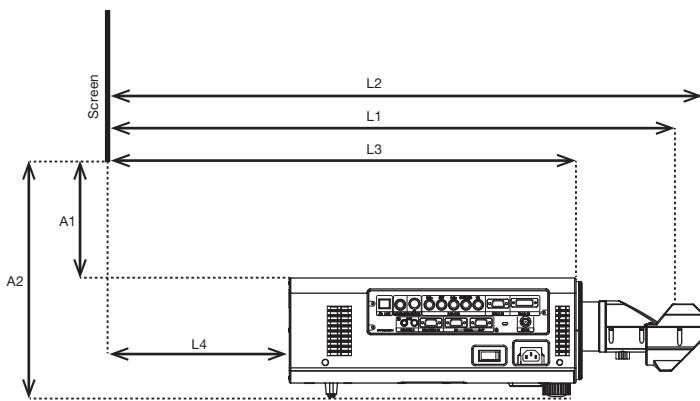

- L1: Projection distance (from screen to mirror reflective surface)
- L2: From screen to tip of lens
- L3: From screen to front of set
- L4: From screen to rear of set
- A1: From bottom edge of screen to top of set
- A2: From bottom edge of screen to bottom of set

Projection Distance Calculation Table

Screen aspect ratio 4:3

Projection distance calculation formula

$$L1 (m) = 0.3628 \times \text{Diagonal image size} + 0.0047$$

Calculation formula for distance from top of set to bottom edge of screen

$$A1 (m) = 0.2238 \times \text{Diagonal image size} - 0.07210$$

**Calculation of the projection distance**

For a screen size different from the above, use the equation below to calculate the projection distance.

**Aspect ratio 16:10**

ET-DLE085	minimum	$L (m) = (\text{diagonal screen size in inches}) \times 0.0174 - 0.0471$
	maximum	$L (m) = (\text{diagonal screen size in inches}) \times 0.0216 - 0.0442$
ET-DLE150	minimum	$L (m) = (\text{diagonal screen size in inches}) \times 0.0286 - 0.0540$
	maximum	$L (m) = (\text{diagonal screen size in inches}) \times 0.0413 - 0.0498$
<i>Supplied lens</i>	<i>minimum</i>	$L (m) = (\text{diagonal screen size in inches}) \times 0.0379 - 0.0746$
	<i>maximum</i>	$L (m) = (\text{diagonal screen size in inches}) \times 0.0529 - 0.0725$
ET-DLE250	minimum	$L (m) = (\text{diagonal screen size in inches}) \times 0.0500 - 0.0800$
	maximum	$L (m) = (\text{diagonal screen size in inches}) \times 0.0789 - 0.0792$
ET-DLE350	minimum	$L (m) = (\text{diagonal screen size in inches}) \times 0.0787 - 0.1351$
	maximum	$L (m) = (\text{diagonal screen size in inches}) \times 0.1190 - 0.1346$
ET-DLE450	minimum	$L (m) = (\text{diagonal screen size in inches}) \times 0.1192 - 0.3017$
	maximum	$L (m) = (\text{diagonal screen size in inches}) \times 0.1885 - 0.2991$
ET-DLE030	(fixed focus)	$L1 (m) = (\text{diagonal screen size in inches}) \times 0.0081 - 0.0047$ $L3 (m) = L1 - 0.166$ $L4 (m) = L1 - 0.679$
ET-DLE055	(fixed focus)	$L (m) = (\text{diagonal screen size in inches}) \times 0.0175 - 0.0476$

**Aspect ratio 16:9**

ET-DLE085	minimum	$L (m) = (\text{diagonal screen size in inches}) \times 0.0179 - 0.0471$
	maximum	$L (m) = (\text{diagonal screen size in inches}) \times 0.0222 - 0.0442$
ET-DLE150	minimum	$L (m) = (\text{diagonal screen size in inches}) \times 0.0294 - 0.0540$
	maximum	$L (m) = (\text{diagonal screen size in inches}) \times 0.0424 - 0.0498$
<i>Supplied lens</i>	<i>minimum</i>	$L (m) = (\text{diagonal screen size in inches}) \times 0.0389 - 0.0746$
	<i>maximum</i>	$L (m) = (\text{diagonal screen size in inches}) \times 0.0543 - 0.0725$
ET-DLE250	minimum	$L (m) = (\text{diagonal screen size in inches}) \times 0.0513 - 0.0800$
	maximum	$L (m) = (\text{diagonal screen size in inches}) \times 0.0811 - 0.0792$
ET-DLE350	minimum	$L (m) = (\text{diagonal screen size in inches}) \times 0.0809 - 0.1351$
	maximum	$L (m) = (\text{diagonal screen size in inches}) \times 0.1223 - 0.1346$
ET-DLE450	minimum	$L (m) = (\text{diagonal screen size in inches}) \times 0.1225 - 0.3017$
	maximum	$L (m) = (\text{diagonal screen size in inches}) \times 0.1937 - 0.2991$
ET-DLE030	(fixed focus)	$L1 (m) = (\text{diagonal screen size in inches}) \times 0.0084 - 0.0047$ $L3 (m) = L1 - 0.166$ $L4 (m) = L1 - 0.679$
ET-DLE055	(fixed focus)	$L (m) = (\text{diagonal screen size in inches}) \times 0.0180 - 0.0476$

**Aspect ratio 4:3**

ET-DLE085	minimum	$L (m) = (\text{diagonal screen size in inches}) \times 0.0197 - 0.0471$
	maximum	$L (m) = (\text{diagonal screen size in inches}) \times 0.0244 - 0.0442$
ET-DLE150	minimum	$L (m) = (\text{diagonal screen size in inches}) \times 0.0324 - 0.0540$
	maximum	$L (m) = (\text{diagonal screen size in inches}) \times 0.0467 - 0.0498$
<i>Supplied lens</i>	<i>minimum</i>	$L (m) = (\text{diagonal screen size in inches}) \times 0.0429 - 0.0746$
	<i>maximum</i>	$L (m) = (\text{diagonal screen size in inches}) \times 0.0599 - 0.0725$
ET-DLE250	minimum	$L (m) = (\text{diagonal screen size in inches}) \times 0.0565 - 0.0800$
	maximum	$L (m) = (\text{diagonal screen size in inches}) \times 0.0893 - 0.0792$
ET-DLE350	minimum	$L (m) = (\text{diagonal screen size in inches}) \times 0.0891 - 0.1351$
	maximum	$L (m) = (\text{diagonal screen size in inches}) \times 0.1347 - 0.1346$
ET-DLE450	minimum	$L (m) = (\text{diagonal screen size in inches}) \times 0.1349 - 0.3017$
	maximum	$L (m) = (\text{diagonal screen size in inches}) \times 0.2133 - 0.2991$
ET-DLE030	(fixed focus)	$L1 (m) = (\text{diagonal screen size in inches}) \times 0.0092 - 0.0047$ $L3 (m) = L1 - 0.166$ $L4 (m) = L1 - 0.679$
ET-DLE055	(fixed focus)	$L (m) = (\text{diagonal screen size in inches}) \times 0.0198 - 0.0476$

• Distances calculated with the above equations will include a slight error.

**Formula for calculating possible heights when using the ET-DLE030**

If using a screen size which has not been previously mentioned, use the following calculation formulas to obtain the possible setting-up height.

For screen aspect ratio of 16:10 Possible setting-up height A1 (mm) = Projection screen size (inches) x 5.0-72.1  
Possible setting-up height A2 (mm) = A1 + 200

For screen aspect ratio of 16:9 Possible setting-up height A1 (mm) = Projection screen size (inches) x 5.9-72.1  
Possible setting-up height A2 (mm) = A1 + 200

For screen aspect ratio of 4:3 Possible setting-up height A1 (mm) = Projection screen size (inches) x 5.7-72.1  
Possible setting-up height A2 (mm) = A1 + 200

\* There may be a small margin of error in the values obtained from the above formulas.

**Shift range**

Optical axis shift function allows to shift the position of a projected image as shown below.

**• Floor mount**

(When the lens except the ET-DLE085 is mounted.)

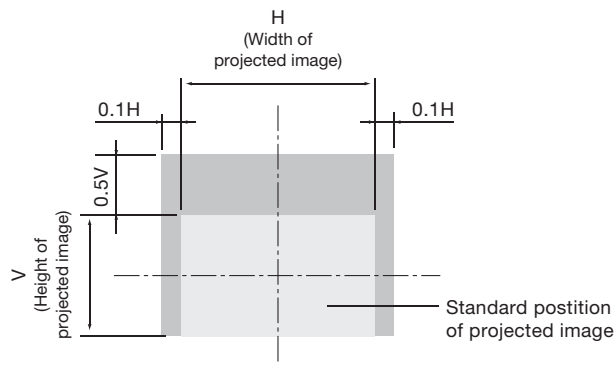

**• Ceiling mount**

(When the lens except the ET-DLE085 is mounted.)

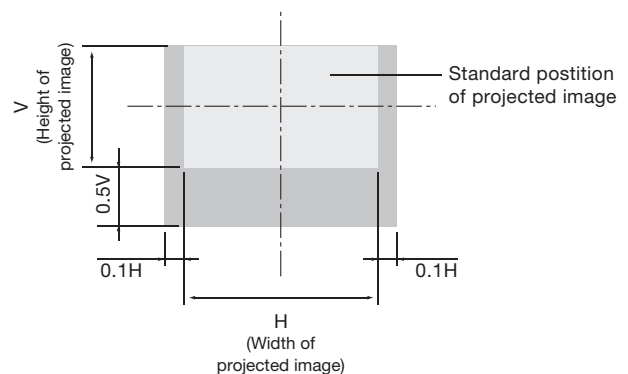

**• Floor mount**

(When the ET-DLE085 is mounted.)

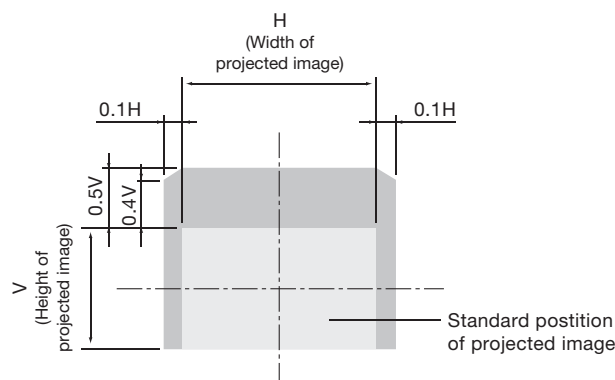

**• Ceiling mount**

(When the ET-DLE085 is mounted.)

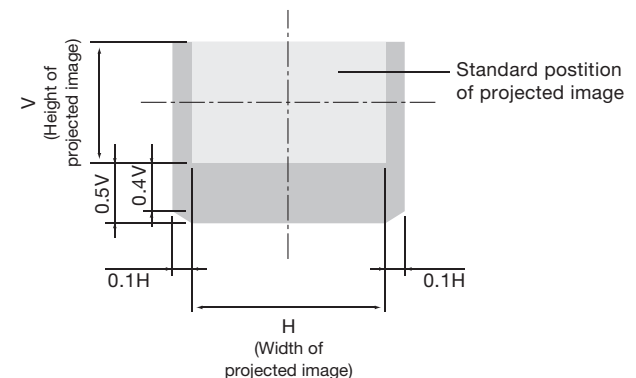

• The ET-DLE055 has a fixed short-focus lens. Therefore, the lens shift function provided in the main unit cannot be used.

**Installable angle**

Install the projector at an angle within the range shown below.

• **Vertical direction**

The projector may be installed at a vertical angle of 360°.

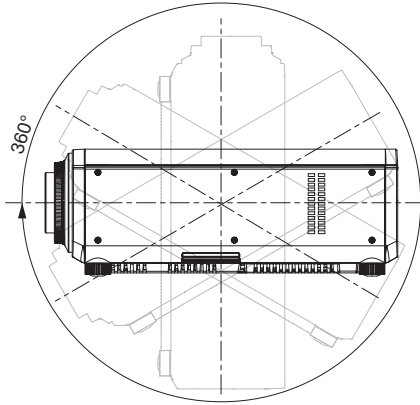

• **Horizontal direction**

The projector may be installed at a horizontal angle of ±15°.

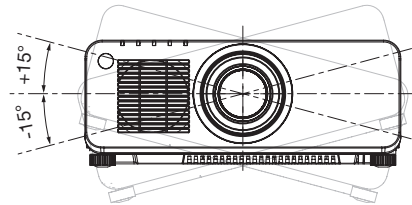

• **Vertical direction in portrait mode with the ET-LAD120P/LAD120PW mounted**

The projector may be installed at a vertical angle of ±15°.

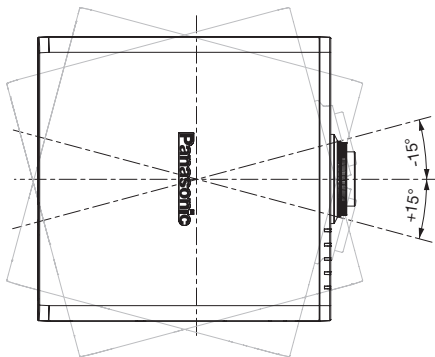

• **Horizontal direction in portrait mode with the ET-LAD120P/LAD120PW mounted**

The projector may be installed at a horizontal angle of ±15°.

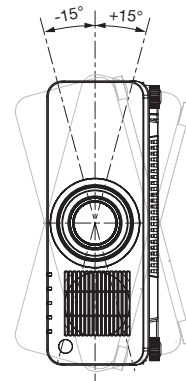

**NOTE:** The projector cannot be vertically installed all by itself. Also, the terminal side must face downward when vertically installed.



**List of compatible signals**

The signals that can be input to this projector are shown in the table below. Horizontal scanning frequencies of 15 kHz to 100 kHz, vertical scanning frequencies of 24 Hz to 120 Hz, and a dot clock of 162 MHz maximum can be input.

**NOTE:** The native resolution of this projector is 1,920 × 1,200 pixels. If the display resolution of the input signal is different from the native resolution, image compression or expansion will be used to convert the input signal to a level within the native resolution.

Display mode	Display resolution (dots)*	Scanning frequency		Dot clock frequency (MHz)	Format
		H (kHz)	V (kHz)		
NTSC/NTSC4.43/PAL-M/PAL60	720 × 480i	15.7	59.9	–	VIDEO/S-VIDEO
PAL/PAL-N/SECAM	720 × 576i	15.6	50.0	–	
525i (480i)	720 × 480i	15.7	59.9	13.5	SDI/YCbCr/RGB
625i (576i)	720 × 576i	15.6	50.0	13.5	
525i (480i)	720(1440) × 480i	15.7	59.9	27.0	HDMI/DVI-D
625i (576i)	720(1440) × 576i	15.6	50.0		
525p (480p)	720 × 483	31.5	59.9	27.0	YCbCr/RGB/ HDMI/DVI-D
625p (576p)	720 × 576	31.3	50.0		
750 (720)/60p	1280 × 720	45.0	60.0	74.3	SDI/YPbPr/RGB/ HDMI/DVI-D
750 (720)/50p		37.5	50.0		
1125 (1080)/60i	1920 × 1080i	33.8	60.0		
1125 (1080)/50i		28.1	50.0		
1125 (1080)/25p	1920 × 1080	28.1	25.0		
1125 (1080)/24p		27.0	24.0		
1125 (1080)/24sF	1920 × 1080i	27.0	48.0		
1125 (1080)/30p	1920 × 1080	33.8	30.0		
1125 (1080)/60p		67.5	60.0	148.5	
1125 (1080)/50p		56.3	50.0		
VGA400	640 × 400	31.5	70.1	25.2	HDMI/DVI-D/RGB
		37.9	85.1	31.5	
VGA480	640 × 480	31.5	59.9	25.2	
		35.0	66.7	30.2	
		37.9	72.8	31.5	
		37.5	75.0	31.5	
		43.3	85.0	36.0	
SVGA	800 × 600	35.2	56.3	36.0	
		37.9	60.3	40.0	
		48.1	72.2	50.0	
		46.9	75.0	49.5	
		53.7	85.1	56.3	
MAC16	832 × 624	49.7	74.6	57.3	
XGA	1024 × 768	39.6	50.0	51.9	
		48.4	60.0	65.0	
		56.5	70.1	75.0	
		60.0	75.0	78.8	
		65.5	81.6	86.0	
		68.7	85.0	94.5	
		81.4	100.0	113.3	
		98.8	120.0	139.1	
MXGA	1152 × 864	53.7	60.0	81.6	
		64.0	70.0	94.2	
		67.5	74.9	108.0	
		77.1	85.0	119.7	
MAC21	1152 × 870	68.7	75.1	100.0	

\* The “i” appearing after the resolution indicates an interlaced signal.

Display mode	Display resolution (dots)*1	Scanning frequency		Dot clock frequency (MHz)	Format
		H (kHz)	V (kHz)		
1280 × 720	1280 × 720	37.1	49.8	60.5	RGB/HDMI/DVI-D
		44.8	59.9	74.5	
		76.3	100.0	131.8	
		92.6	120.0	161.6	
1280 × 768	1280 × 768	39.6	49.9	65.3	
	1280 × 768*2	47.4	60.0	68.3	
	1280 × 768	47.8	59.9	79.5	
		60.3	74.9	102.3	
		68.6	84.9	117.5	
		41.3	50.0	68.0	
		49.3	59.9	71.0	
		49.7	59.8	83.5	
1280 × 800	1280 × 800	41.3	50.0	68.0	
	1280 × 800*2	49.3	59.9	71.0	
	1280 × 800	49.7	59.8	83.5	
		62.8	74.9	106.5	
		71.6	84.9	122.5	
		60.0	60.0	108.0	
		52.4	50.0	88.0	
		64.0	60.0	108.0	
MSXGA	1280 × 960	72.3	66.3	125.0	
		78.2	72.0	135.1	
		80.0	75.0	135.0	
		91.1	85.0	157.5	
SXGA	1280 × 1024	39.6	49.9	69.0	
		47.7	59.8	85.5	
		54.1	50.0	99.9	
		64.0	60.0	108.0	
1366×768	1366 × 768	65.2	60.0	122.6	
		65.3	60.0	121.8	
		78.8	72.0	149.3	
		82.2	75.0	155.9	
SXGA+	1400 × 1050	46.3	49.9	86.8	
		55.9	59.9	106.5	
		75.0	60.0	162.0	
		54.1	50.0	119.5	
WXGA+	1440 × 900	65.3	60.0	146.3	
		55.6	49.9	141.5	
		66.6	59.9	138.5	
		67.2	60.0	173.0	
UXGA60	1600 × 1200	55.6	49.9	141.5	RGB
	1920 × 1080*2	66.6	59.9	138.5	
	1920 × 1080	67.2	60.0	173.0	
	61.8	49.9	158.3		
WSXGA+	1680 × 1050	54.1	50.0	119.5	RGB/HDMI/DVI-D
	1920 × 1080	74.0	60.0	154.0	
		74.6	59.9	193.3	
	1920 × 1080	74.6	59.9	193.3	
WUXGA	1920 × 1080	55.6	49.9	141.5	RGB
	1920 × 1200	61.8	49.9	158.3	
	1920 × 1200*2	74.0	60.0	154.0	
	1920 × 1080	74.6	59.9	193.3	

\*1 The “i” appearing after the resolution indicates an interlaced signal.  
 \*2 Compliant with VESA CVT-RB (Coordinated Video Timing-Reduced Blanking).

**NOTE: DIGITAL LINK and HDMI inputs share the same compatible signal.**

**List of compatible 3D signals**

The 3D signals that can be input to this projector are shown in the table below.

Display mode	Display resolution (dots)*1	Scanning frequency		Dot clock frequency (MHz)	HDMI			DVI			
		H (kHz)	V (kHz)		Frame packing	Side by side*2	Top and bottom	Side by side*2	Top and bottom	Line by line	Frame sequential
750 (720)/60p	1280 × 720	45.0	60.0	74.3	Yes	Yes	Yes	Yes	Yes	Yes	-
750 (720)/50p		37.5	50.0	74.3							
1125 (1080)/60i	1920 × 1080i	33.8	60.0	74.3	-	-	-	-	-	-	-
1125 (1080)/50i		28.1	50.0	74.3							
1125 (1080)/25p	1920 × 1080	28.1	25.0	74.3	-	-	-	-	-	-	-
1125 (1080)/24p		27.0	24.0	74.3							
1125 (1080)/24sF	1920 × 1080i	27.0	48.0	74.3	-	-	-	-	-	-	-
1125 (1080)/30p	1920 × 1080	33.8	30.0	74.3	-	-	-	-	-	-	-
1125 (1080)/60p		67.5	60.0	148.5							
1125 (1080)/50p	VGA480	56.3	50.0	148.5	-	-	-	-	-	-	-
		31.5	59.9	25.2							
SVGA	800 × 600	37.9	60.3	40.0	-	-	-	-	-	-	-
XGA	1024 × 768	39.6	50.0	51.9	Yes	Yes	Yes	-	-	-	-
		48.4	60.0	65.0							
		81.4	100.0	113.3							
		98.8	120.0	139.1							
MXGA	1152 × 864	53.7	60.0	81.6	-	-	-	-	-	-	-
1280 × 720	1280 × 720	37.1	49.8	60.5	-	-	-	-	-	-	-
		44.8	59.9	74.5							
		76.3	100.0	131.8							
		92.6	120.0	161.6							
1280 × 768	1280 × 768	39.6	49.9	65.3	-	-	-	-	-	-	-
		47.8	59.9	79.5							
1280 × 768	1280 × 768 *3	47.4	60.0	68.3	-	-	-	-	-	-	-
	49.7	59.8	83.5								
1280 × 800	1280 × 800	41.3	50.0	68.0	Yes	Yes	Yes	-	-	-	-
		49.3	59.9	71.0							
MSXGA	1280 × 960	60.0	60.0	108.0	-	-	-	-	-	-	-
SXGA	1280 × 1024	52.4	50.0	88.0	-	-	-	-	-	-	-
		64.0	60.0	108.0							
1366 × 768	1366 × 768	47.7	59.8	85.5	-	-	-	-	-	-	-
		39.6	49.9	69.0							
SXGA+	1400 × 1050	54.1	50.0	99.9	-	-	-	-	-	-	-
		64.0	60.0	108.0							
		65.2	60.0	122.6							
		65.3	60.0	121.8							
WXGA+	1440 × 900	55.9	59.9	106.5	-	-	-	-	-	-	-
		46.3	49.9	86.8							
UXGA60	1600 × 1200	75.0	60.0	162.0	-	-	-	-	-	-	-
WSXGA+	1680 × 1050	65.3	60.0	146.3	-	-	-	-	-	-	-
		54.1	50.0	119.5							
1920 × 1080	1920 × 1080	55.6	49.9	141.5	-	-	-	-	-	-	-
	1920 × 1080 *3	66.6	59.9	138.5							
WUXGA	1920 × 1200	61.8	49.9	158.3	-	-	-	-	-	-	-
	1920 × 1200 *3	74.0	60.0	154.0							

\*1 The "i" appearing after the resolution indicates an interlaced signal.  
 \*2 Compatible with half-resolution signals.  
 \*3 Compliant with VESA CVT-RB (Coordinated Video Timing-Reduced Blanking).

Display mode	Display resolution (dots)*1	Scanning frequency		Dot clock frequency (MHz)	RGB1/RGB2				SDI			HDMI & DVI	RGB1 & RGB2	3G-SDI Level B	
		H (kHz)	V (kHz)		Side by side*2	Top and bottom	Line by line	Frame sequential	Side by side*2	Top and bottom	Line by line	Simultaneous	Simultaneous	Simultaneous	
750 (720)/60p	1280 × 720	45.0	60.0	74.3	Yes	Yes	Yes	-	Yes	Yes	Yes	Yes	Yes	Yes	
750 (720)/50p		37.5	50.0	74.3											
1125 (1080)/60i	1920 × 1080i	33.8	60.0	74.3	Yes	Yes	-	-	Yes	Yes	Yes	Yes	Yes	Yes	
1125 (1080)/50i		28.1	50.0	74.3											
1125 (1080)/25p	1920 × 1080	28.1	25.0	74.3	Yes	Yes	-	-	Yes	Yes	Yes	Yes	Yes	Yes	
1125 (1080)/24p		27.0	24.0	74.3											
1125 (1080)/24sF	1920 × 1080i	27.0	48.0	74.3	Yes	Yes	-	-	Yes	Yes	Yes	Yes	Yes	Yes	
1125 (1080)/30p	1920 × 1080	33.8	30.0	74.3											
1125 (1080)/60p	1920 × 1080	67.5	60.0	148.5	Yes	Yes	-	-	Yes	Yes	Yes	Yes	Yes	Yes	
1125 (1080)/50p		56.3	50.0	148.5											
VGA480	640 × 480	31.5	59.9	25.2	Yes	-	-	-	-	-	-	-	-	-	
SVGA	800 × 600	37.9	60.3	40.0											
XGA	1024 × 768	39.6	50.0	51.9	Yes	-	-	-	-	-	-	-	-	-	-
		48.4	60.0	65.0											
		81.4	100.0	113.3											
		98.8	120.0	139.1											
MXGA	1152 × 864	53.7	60.0	81.6	Yes	-	-	-	-	-	-	-	-	-	
1280 × 720	1280 × 720	37.1	49.8	60.5											
		44.8	59.9	74.5											
		76.3	100.0	131.8											
1280 × 768	1280 × 768	92.6	120.0	161.6	Yes	-	-	-	-	-	-	-	-	-	
		39.6	49.9	65.3											
		47.8	59.9	79.5											
		47.4	60.0	68.3											
1280 × 800	1280 × 800	41.3	50.0	68.0	Yes	-	-	-	-	-	-	-	-	-	
		49.7	59.8	83.5											
1280 × 800	1280 × 800 *3	49.3	59.9	71.0	Yes	-	-	-	-	-	-	-	-	-	
		49.3	59.9	71.0											
MSXGA	1280 × 960	60.0	60.0	108.0	Yes	-	-	-	-	-	-	-	-	-	
SXGA	1280 × 1024	52.4	50.0	88.0											
1366 × 768	1366 × 768	64.0	60.0	108.0	Yes	-	-	-	-	-	-	-	-	-	
		39.6	49.9	69.0											
SXGA+	1400 × 1050	47.7	59.8	85.5	Yes	-	-	-	-	-	-	-	-	-	
		54.1	50.0	99.9											
WXGA+	1440 × 900	64.0	60.0	108.0	Yes	-	-	-	-	-	-	-	-	-	
		65.2	60.0	122.6											
		65.3	60.0	121.8											
UXGA60	1600 × 1200	55.9	59.9	106.5	Yes	-	-	-	-	-	-	-	-	-	
WSXGA+	1680 × 1050	46.3	49.9	86.8											
1920 × 1080	1920 × 1080	75.0	60.0	162.0	Yes	-	-	-	-	-	-	-	-	-	
		65.3	60.0	146.3											
WUXGA	1920 × 1200	54.1	50.0	119.5	Yes	-	-	-	-	-	-	-	-	-	
		55.6	49.9	141.5											
1920 × 1080	1920 × 1080 *3	66.6	59.9	138.5	Yes	-	-	-	-	-	-	-	-	-	
		61.8	49.9	158.3											
1920 × 1200	1920 × 1200 *3	74.0	60.0	154.0	Yes	-	-	-	-	-	-	-	-	-	
		74.0	60.0	154.0											

\*1 The “i” appearing after the resolution indicates an interlaced signal.  
 \*2 Compatible with half-resolution signals.  
 \*3 Compliant with VESA CVT-RB (Coordinated Video Timing-Reduced Blanking).

NOTE: DIGITAL LINK and HDMI inputs share the same compatible signal.

**Serial connector**

The serial connector complies with RS-232C. To control the projector from a personal computer, commands must be input through communication software, based on the format and satisfying the communication conditions shown below.

**Pin assignments and signal names**

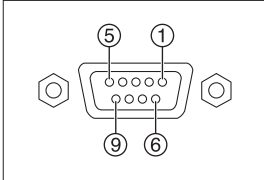

D-sub 9-pin (female) Serial input

No.	Signal name	Description	No.	Signal name	Description
1	-	NC	6	-	NC
2	TXD	Send data	7	CTS	Connected internally
3	RXD	Receive data	8	RTS	Connected internally
4	-	NC	9	-	NC
5	GND	Ground			

**Pin assignments and signal names**

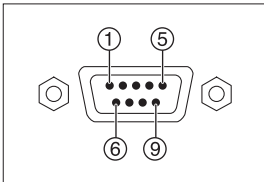

D-sub 9-pin (male) Serial output

No.	Signal name	Description	No.	Signal name	Description
1	-	NC	6	-	NC
2	RXD	Receive data	7	RTS	Connected internally
3	TXD	Send data	8	CTS	Connected internally
4	-	NC	9	-	NC
5	GND	Ground			

**Communication conditions (factory setting)**

Signal level	RS-232C-compliant
Synchronization method	Start-stop synchronization
Baud rate	9,600 bps
Parity	None
Character length	8 bits
Stop bit	1 bit
X parameter	None
S parameter	None

**Basic format**

Transmission from the computer begins with STX, then the ID, command, parameter, and ETX are sent in this order. Add parameters according to the details of control.

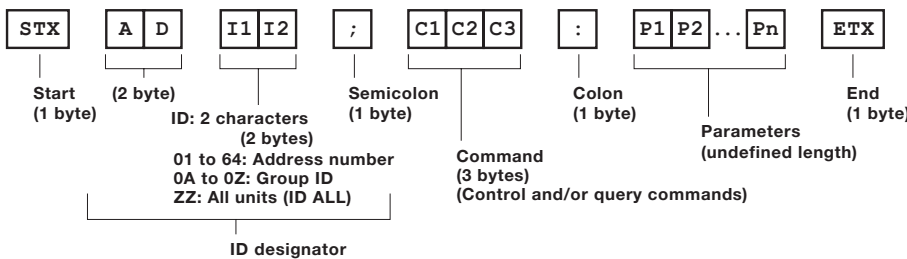

**CAUTION**

- It may not be possible to send or receive commands for about 10 to 60 seconds when the lamp is first turned on. If this occurs, wait for 60 seconds, then try sending or receiving again.
- When sending multiple commands, be sure to wait for at least 0.5 second after receiving a response from the projector before sending the next command.
- Additional time is sometimes required for response due to processing inside the projector. Set the time-out period for command response to 10 seconds or more.
- When using two or more units:
  - 1) Set different IDs for each unit.
  - 2) Designate only one unit as RESPONSE (ID ALL) ON and the rest as RESPONSE (ID ALL) OFF.
  - 3) Each group should have only one RESPONSE (ID GROUP) ON and the rest should be RESPONSE (ID GROUP) OFF.

**Cable specifications**

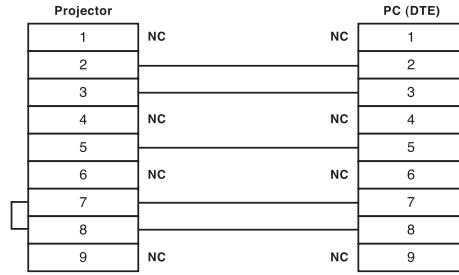

**Control commands**

Command : Parameter	Function		Callback
<b>PON</b>	POWER (STANDBY)	Standby power on	<b>PON</b>
<b>POF</b>		Standby power off	<b>POF</b>
<b>OSH : 0</b>	SHUTTER	Shutter off	<b>OSH : 0</b>
<b>OSH : 1</b>		Shutter on	<b>OSH : 1</b>
<b>IIS : SDI</b>	INPUT SELECT	SDI	<b>IIS : SDI</b>
<b>IIS : DL1</b>		DIGITAL LINK	<b>IIS : DL1</b>
<b>IIS : HD1</b>		HDMI	<b>IIS : HD1</b>
<b>IIS : DVI</b>		DVI	<b>IIS : DVI</b>
<b>IIS : RG1</b>		RGB 1	<b>IIS : RG1</b>
<b>IIS : RG2</b>		RGB 2	<b>IIS : RG2</b>
<b>IIS : VID</b>		Video	<b>IIS : VID</b>
<b>VXX : RYC1=+00000</b>	RGB INPUT SETTING	RGB/YCbCr/RGB	<b>VXX : RYC1=+00000</b>
<b>VXX : RYC1=+00001</b>		S-Video	<b>VXX : RYC1=+00001</b>
<b>IIS : DL1 : HD1</b>	When an ET-YFB100G digital interface box is connected, the ET-YFB100G input switches at the same time as input is switched to the digital link input.	HDMI 1	<b>IIS : DL1 : HD1</b>
<b>IIS : DL1 : HD2</b>		HDMI 2	<b>IIS : DL1 : HD2</b>
<b>IIS : DL1 : PC1</b>		Computer 1	<b>IIS : DL1 : PC1</b>
<b>IIS : DL1 : PC2</b>		Computer 2	<b>IIS : DL1 : PC2</b>
<b>IIS : DL1 : VID</b>		Video	<b>IIS : DL1 : VID</b>
<b>IIS : DL1 : SVD</b>		S-Video	<b>IIS : DL1 : SVD</b>
<b>LPM : 0</b>		LAMP SELECT	Dual (two lamps)
<b>LPM : 1</b>		Single lamp	<b>LPM : 1</b>
<b>LPM : 2</b>		Lamp 1	<b>LPM : 2</b>
<b>LPM : 3</b>		Lamp 2	<b>LPM : 3</b>
<b>OLP : 0</b>	Lamp power	Normal	<b>OLP : 0</b>
<b>OLP : 1</b>		Eco	<b>OLP : 1</b>
<b>VSE : 1</b>	ASPECT RATIO SWITCHING	Standard/VID Auto	<b>VSE : 1</b>
<b>VSE : 2</b>		4:3	<b>VSE : 2</b>
<b>VSE : 5</b>		16:9	<b>VSE : 5</b>
<b>VSE : 6</b>		HV fit	<b>VSE : 6</b>
<b>VSE : 9</b>		H fit	<b>VSE : 9</b>
<b>VSE : 10</b>		V fit	<b>VSE : 10</b>
<b>OAS</b>	AUTO SETUP		<b>OAS</b>
<b>VPM : NAT</b>	PICTURE MODE	Natural	<b>VPM : NAT</b>
<b>VPM : STD</b>		Standard	<b>VPM : STD</b>
<b>VPM : DYN</b>		Dynamic	<b>VPM : DYN</b>
<b>VPM : CIN</b>		Cinema	<b>VPM : CIN</b>
<b>VPM : GRA</b>		Graphic	<b>VPM : GRA</b>
<b>VPM : 709</b>		Rec.709	<b>VPM : 709</b>
<b>VPM : DIC</b>		DICOM	<b>VPM : DIC</b>
<b>VXX : DLVI0=+00000</b>	SYSTEM DAYLIGHT VIEW	Off	<b>VXX : DLVI0=+00000</b>
<b>VXX : DLVI0=+00001</b>		1	<b>VXX : DLVI0=+00001</b>
<b>VXX : DLVI0=+00002</b>		2	<b>VXX : DLVI0=+00002</b>
<b>VXX : DLVI0=+00003</b>		3	<b>VXX : DLVI0=+00003</b>
<b>OTE : 4</b>	COLOR TEMPERATURE	User 1	<b>OTE : 4</b>
<b>OTE : 9</b>		User 2	<b>OTE : 9</b>
<b>OTE : 10</b>		Default	<b>OTE : 10</b>
<b>OTE : 3200</b>		3200K	<b>OTE : 3200</b>
<b>OTE : 3300</b>		3200K	<b>OTE : 3300</b>
<b>:</b>		:	<b>:</b>
<b>OTE : 9200</b>		3200K	<b>OTE : 9200</b>
<b>OTE : 9300</b>		3200K	<b>OTE : 9300</b>
<b>TSD : y1y2y3y4m1m2d1d2w</b>	DATE	Date setting	<b>TSD : y1y2y3y4m1m2d1d2w</b>
<b>TST : h1h2m1m2s1s2</b>	TIME	Time setting	<b>TST : h1h2m1m2s1s2</b>
<b>OOS : 0</b>	ON SCREEN	On-screen display off	<b>OOS : 0</b>
<b>OOS : 1</b>		On-screen display on	<b>OOS : 1</b>

\* Do not send PON, POF, or OSH commands continuously in a short period of time. Doing so may burst the lamp or shorten the lamp replacement cycle.  
 \* When a command that cannot be executed during standby mode is sent, the projector will send an ER401 command in reply.

**Status request commands**

Command:Parameter	Function	Callback	Description
<b>QPW</b>	Main power status	000	Off
		001	On
<b>QSH</b>	Shutter function status	0	Off
		1	On
<b>QIN</b>	Input signal status	<b>SDI</b>	SDI
		<b>DL1</b>	DIGITAL LINK
		<b>HD1</b>	HDMI
		<b>DVI</b>	DVI
		<b>RG1</b>	RGB 1
		<b>RG2</b>	RGB 2
		<b>VID</b>	Video
		<b>DL1 : HD1</b>	HDMI 1
		<b>DL1 : HD2</b>	HDMI 2
		<b>DL1 : PC1</b>	Computer 1
<b>DL1 : PC2</b>	Computer 2		
<b>DL1 : VID</b>	Video		
<b>DL1 : SVD</b>	S-Video		
<b>QSL</b>	Lamp operation mode status	0	Dual (two lamps)
		1	Single lamp
		2	lamp 1
		3	lamp 2
<b>QLP</b>	Lamp power mode status	0	Normal
		1	Eco
<b>QPM</b>	Picture mode status	<b>NAT</b>	Natural
		<b>STD</b>	Standard
		<b>DYN</b>	Dynamic
		<b>CIN</b>	Cinema
		<b>GRA</b>	Graphic
		<b>709</b>	Rec. 709
		<b>DIC</b>	DICOM
<b>QVX : DLVIO</b>	System daylight view status	<b>DLVIO=+00000</b>	Off
		<b>DLVIO=+00001</b>	1
		<b>DLVIO=+00002</b>	2
		<b>DLVIO=+00003</b>	3
<b>QST</b>	Projector run time	<b>p1p2p3p4p5</b>	00000h-99999h
<b>Q\$L : 1</b>	Lamp 1 run time	<b>p1p2p3p4</b>	0000h-9999h
<b>Q\$L : 2</b>	Lamp 2 run time	<b>p1p2p3p4</b>	0000h-9999h
<b>QTM : 0</b>	Temperature status	<b>p1p2p3p4 / p5p6p7p8*1</b>	p0 = Intake air
<b>QTM : 1</b>			p1 = Around lamp
<b>QTM : 2</b>			p2 = Optics module
<b>QGD</b>	Date setting status	<b>y1y2y3y4m1m2d1d2w</b>	yyyymmdd (day of week)*2
<b>QGT</b>	Time setting status	<b>h1h2m1m2s1s2</b>	hhmmss*3
<b>QOS</b>	On-screen display status	0	Off
		1	On

\*1 p1p2p3p4: Celsius (°C), p5p6p7p8: Fahrenheit (°F)

\*2 Day of week: Monday = 1, Tuesday = 2, ... Sunday = 7

\*3 Set the date and time to UTC (universal time coordinated).

\* When a wrong command is sent, the projector will send an ER401 or ER402 command in reply.

**Command example**

To set the on-screen display off, send the command as shown below.



NOTE: When sending commands without parameters, a colon (:) is not necessary.

**Notes on projector placement and operation**

The projector uses a high-wattage lamp that becomes very hot during operation. Please observe the following precautions.

1. Never place objects on top of the projector.
2. Make sure there is an unobstructed space of 500 mm (1 feet 8 inches) or more around the projector's exhaust openings.
3. Do not stack projector units directly on top of one another for the purpose of multiple (stacked) projection. When stacking projector units, be sure to provide the amount of space indicated below between them. These space requirements also apply to installations where only one projector unit is operating at one time and the other unit is used as a backup.
4. Make sure that nothing blocks the projector's air intake and exhaust openings. Also, install the projector so that cool or hot air from other air conditioning equipment does not flow directly toward the projector's air intake or exhaust openings.
5. Do not install the projector in an enclosed space. If it is necessary to install it in an enclosed space, add a separate ventilation system. If ventilation is insufficient, hot air will accumulate at the intake opening. This may cause the projector's protective circuit to interrupt projector operation.
6. If the projector is installed in an enclosed space, ensure that the projector's intake and exhaust openings are not blocked. Take particular care to ensure that hot air from the exhaust openings is not sucked into the intake openings.
7. When installing the projector in any manner other than floor mounting with the adjuster legs, use the six threaded ceiling mount holes (screw diameter: M6, projector interior thread length: 12 mm) to secure the projector.

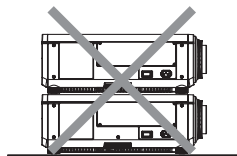
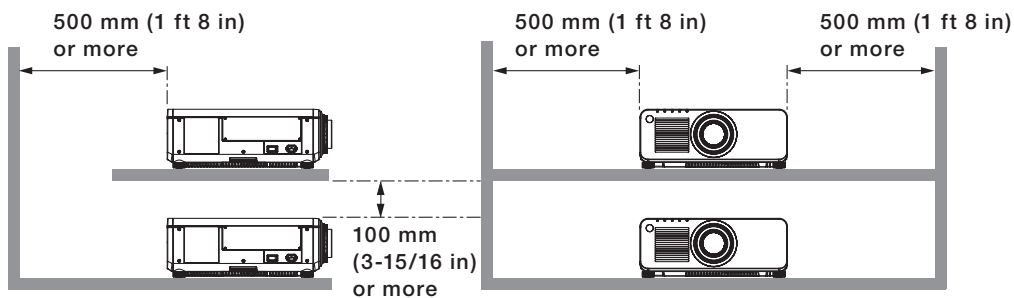

Do not stack projector units directly on top of one another.

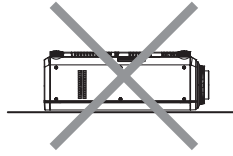

Do not support the projector unit by its top while it is in use.



Direction of air intake and exhaust

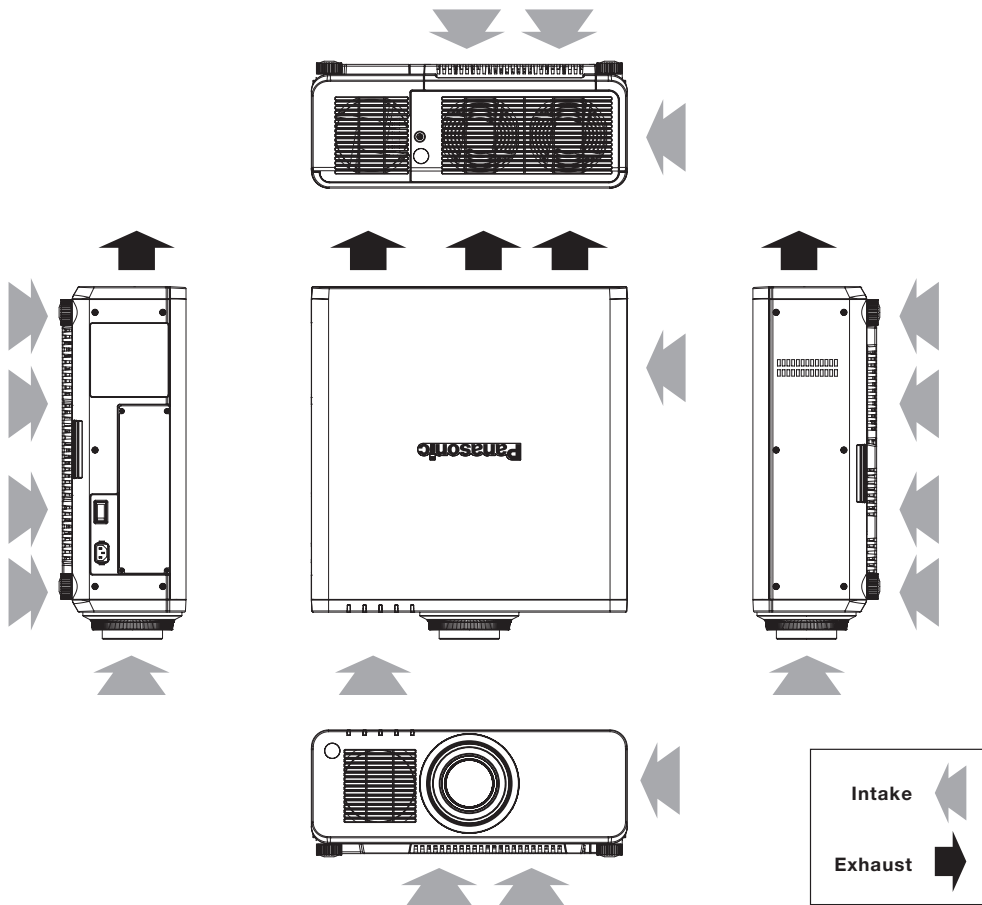

Operating the projector continuously

1. If the projector is to be operated continuously for one week, use the dual-lamp optical system's alternating lamp operation (lamp relay) function. The projector cannot be operated continuously one week in dual-lamp mode. Allow a minimum of two hours per day of non-operation time for each lamp if the projector is to be operated continuously for more than one week.
2. The lamp replacement cycle duration becomes shorter if the projector is operated repeatedly for short periods.

Weights and dimensions shown are approximate. Specifications and appearance are subject to change without notice. Product availability differs depending on region and country. This product may be subject to export control regulations.

DLP and the DLP logo are trademarks of Texas Instruments. HDMI, the HDMI logo and High-Definition Multimedia Interface are trademarks or registered trademarks of HDMI Licensing LLC in the United States and other countries. PJLink is a registered trademark, or a trademark application has been filed, in Japan, the United States, and other countries and regions. All other trademarks are the property of their respective trademark owners.