



Source 4*VRD*[™]

HPL to LED Retrofit

Installation and User Manual

revision D

v 1.0

LED fixtures are intended for professional use only.
Read this entire document before using this product.

Copyright © 2016 Electronic Theatre Controls, Inc.
All rights reserved. Product information and specifications subject to change.

Part Number: **7067M1200-1.0.0**

Released: March 2016

ETC[®], Eos[®], Source Four[®], Source 4WRD[™] and Unison[®] are either registered trademarks or trademarks of Electronic Theatre Controls, Inc. in the United States and other countries.

All other trademarks, both marked and not marked, are the property of their respective owners.

This product is protected by one or more of the following U.S. Patents:
US 9,261,241 and 9,273,831

ETC intends this document, whether printed or electronic, to be provided in its entirety.

Table of Contents

Safety	2
Specifications	3
Sensor dimmer settings	3
Color rendering and quality	5
Contacting ETC	5
Retrofit Kit Installation	6
Remove Incandescent Lamp Housing	6
Install Source 4WRD	7
Fixture Installation	8
C-clamp and safety cable	8
Connect cables	9
DMX pinout	9
User Interface	10
Error codes:	10
Focus the fixture	11
Z-adjustment Knob	11
Adjust the yoke position	11
Shape the beam	12
Color Frame	12
Pattern Projection	13
Cleaning and Maintenance	13
Cleaning Source 4WRD	13
Cleaning Lenses	14
Cleaning Reflector	14
Cleaning 5° and 10° polymer lenses	15

Introduction

Congratulations on your purchase of the ETC Source 4WRD. Replacing your existing incandescent burner assembly with the Source 4WRD LED retrofit brings a new tool to your lighting inventory. Source 4WRD expands the options for existing Source Four fixtures and adds a new white LED fixture to the ETC family.

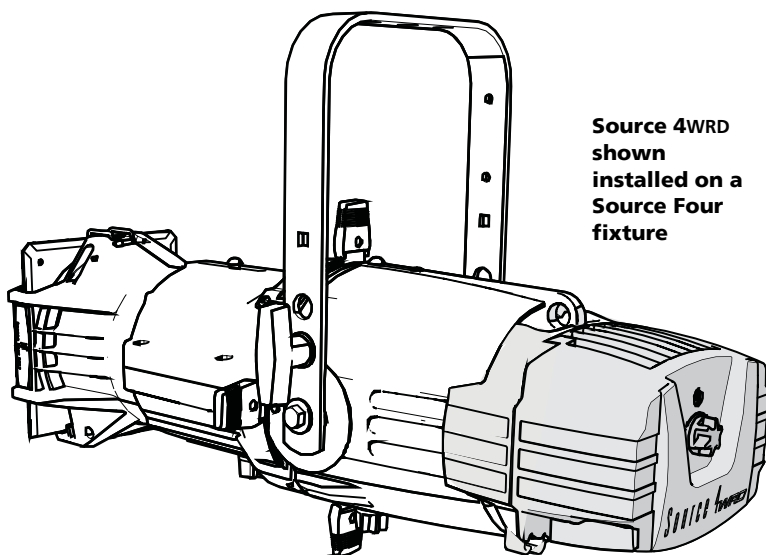

The following Source 4WRD options are available as 80CRI and 90 CRI (Gallery) variants:

- **Source 4WRD Retrofit Kit:** Used to modify an existing Source Four HPL incandescent fixture to a white LED fixture.
- **Source 4WRD Light Engine:** Combines the Source Four incandescent fixture body with the Source 4WRD white LED Retrofit Kit.



Note: *Source 4WRD Retrofit Kit is not compatible with Source Four LED, Fresnel, PAR, or jr fixtures.*



WARNING: **Source 4WRD is not user serviceable. Field modification of the Source 4WRD will void your ETC warranty.**

ETC User Manual

Safety

The Source 4WRD fixture is intended for professional use only. **Read the entire manual before using this equipment.**



WARNING: Note the following safety warnings before use:

- Do not mount the Source 4WRD fixture on or near a flammable surface.
- Do not use the Source 4WRD below 5°C (41°F). When the fixture has been stored or transported in freezing temperatures, allow it to warm to room temperature for a minimum of 1 hour prior to applying power. Applying power to a frozen fixture will cause damage to the fixture and void ETC warranty.
- Do not use this fixture with a damaged power lead. If the power lead (cord set) is damaged, it must be replaced.
- Do not use this fixture if glass lens is deeply scratched or cracked. Damaged lenses must be replaced.
- To prevent wiring damage, or abrasion, do not expose wiring to edges of sheet metal or other sharp objects.
- Use the Source 4WRD fixture in dry locations only, where humidity does not exceed 90 percent (non-condensing). These fixtures are not intended for outdoor use.
- Mount and support the fixture only by the primary suspension holes in the yoke.
- Suspend the fixture from a suitable structure using only the hardware rated for the weight of the fixture.
- In addition to primary suspension, attach a safety cable (ETC Model 400SC or other approved safety cable or device) to the fixture housing. Appropriate attachment point (hole) is provided in the protruding tab on the fixture housing.
- Disconnect the unit from power and DMX and allow the fixture to cool before removing or installing the shutter barrel or other adapters, and for performing all cleaning and maintenance.



Note:

- Maximum recommended ambient operating temperature: $T_a=40^{\circ}\text{C}$ (104°F)
 - Maximum anticipated external surface temperature: $T_{\text{max}}=65^{\circ}\text{C}$ (149°F) at $T_a=40^{\circ}\text{C}$ (104°F)
 - External Temperature (steady state achieved) at 25°C (77°F) ambient: 32°C (90°F)
-

Specifications

Typical Power Consumption

Idle Power / Current	DMX Mode: 1.2W/0.046A AC Mode: 0W
Full Intensity Power / Current	155.7W/1.35A

Physical

- Rugged die-cast aluminum construction
- Advanced thermal management systems for long LED life
- Ambient operating temperature
5 to 40 °C (41 to 104°F)
- Weight
S4WRD retrofit kit only: 3.65 lbs
S4WRD installed on 26° fixture with yoke and c-clamp: 14 lbs.

Electrical

- 114-125VAC 60Hz power input
- 155 watt draw at full (182 watt theoretical max. draw)
- Recommended two (2) Source 4WRD fixtures per dimmed circuit (D20 module)
- Max of 14 fixtures per non-dimmed circuit (R20 module)
- If using in DMX mode, connect fixture to relay, constant power, or dimmer with regulation off and parked at full

LEDs

- 4 CREE LED modules
- 30,000 hour estimated L70 rating. Life-test in progress, results pending.

Optical

- Compatible with all ETC Source Four lens tubes.

Control

- DMX512-A compliant
- DMX in and thru via two RJ45 connectors
- Simple seven segment display, two button user interface
- AC power for line-dimmed operation

Sensor dimmer settings

The Source 4WRD can be controlled from either a DMX source or from an existing dimmer for level control.

When powering a fixture from a CEM classic, CEM+, or CEM3 for DMX dimming or AC level setting, change max scale settings to guarantee the dimmer is out of regulated mode.



Note: *Dimmer settings may need to be adjusted for optimal fixture control.*

ETC User Manual

The following table applies to all ETC Sensor control modules including CEM, CEM+, and CEM3.



Note: In CEM+ Max Scale **must** be set to 140V to guarantee that regulation is off.

Parameter	Value
Curve	Mod Square
Threshold	1%
Min Scale	6V
Max Scale	140V
Regulation	OFF
Preheat	Disabled
DC Prevent	OFF
Inrush Protect	OFF
Scale Load	100



Note: With AC dimming (line-dimmed) mode, performance may vary based on the control settings of the dimmer used. For this reason, ETC recommends using AC dimming for level-setting or for architectural quality dimming situations. ETC recommends testing Source 4WRD on all existing dimmers you wish to use.
Use DMX mode when high-performance, live, dynamic dimming is required.

The SCR Off Time may need to be increased from the default setting. Contact ETC for assistance in changing the SCR off time, or any other CEM classic, CEM+, or CEM3 settings.

For the most current information on additional dimmer performance testing for both ETC and non-ETC dimmers, please reference our website at: <http://www.etcconnect.com/Support/Articles/Dimmer-Settings-for-Use-with-Source-4wrD.aspx>

Color rendering and quality

Source 4WRD fixtures are evaluated for Color Rendering Index (CRI) and Color Quality Scale (CQS) performance using measured output spectrum. These numbers may fluctuate slightly from fixture to fixture. This is a normal characteristic of white LEDs, and this kind of variation is highly unlikely to be apparent in most applications.

Fixture	CRI	CQS	Color Fidelity	Duv
Source 4WRD (80CRI) at 3000K	≥ 80	80	80	0.001
Source 4WRD Gallery (90CRI) at 3000K	≥ 90	90	90	0.001

Contacting ETC

If you are having difficulties, your most convenient resources are the references given in this user manual. To search more widely, try the ETC Web site at www.etcconnect.com. If none of these resources is sufficient, contact ETC Technical Services directly at one of the offices identified below. Emergency service is available from all ETC offices outside of normal business hours.

When calling for help, please have the following information handy:

- Product model
- Dimmer manufacturer and installation type
- Other components in your system (Unison, other consoles, etc.)

Americas

Electronic Theatre Controls Inc.
Technical Services Department
3031 Pleasant View Road
Middleton, WI 53562
800-775-4382 (USA, toll-free)
+1-608 831-4116
service@etcconnect.com

Asia

Electronic Theatre Controls Asia, Ltd.
Technical Services Department
Room 1801, 18/F
Tower 1, Phase 1 Enterprise Square
9 Sheung Yuet Road
Kowloon Bay, Kowloon, Hong Kong
+852 2799 1220
service@etcasia.com

United Kingdom

Electronic Theatre Controls Ltd.
Technical Services Department
26-28 Victoria Industrial Estate
Victoria Road,
London W3 6UU England
+44 (0)20 8896 1000
service@etceurope.com

Germany

Electronic Theatre Controls GmbH
Technical Services Department
Ohmstrasse 3
83607 Holzkirchen, Germany
+49 (80 24) 47 00-0
techserv-hoki@etcconnect.com

ETC User Manual

Retrofit Kit Installation



WARNING: ***RISK OF FIRE OR ELECTRIC SHOCK:** LED Retrofit Kit installation requires knowledge of luminaire electrical systems. If not qualified, do not attempt installation. Contact a qualified electrician.*



Note: *THE RETROFIT KIT IS ACCEPTABLE AS A COMPONENT OF A LUMINAIRE WHERE THE SUITABILITY OF THE COMBINATION SHALL BE DETERMINED BY AUTHORITIES HAVING JURISDICTION.*

A #2 Phillips screwdriver is needed for kit installation

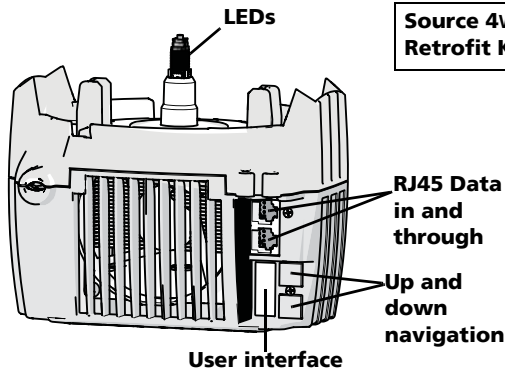

Remove Incandescent Lamp Housing

- Step 1: Unplug the Source Four incandescent fixture and place it on a flat, stable surface.
- Step 2: Loosen the brass thumb screw located above the beam adjustment knob. The lamp housing is now loose and can be removed.

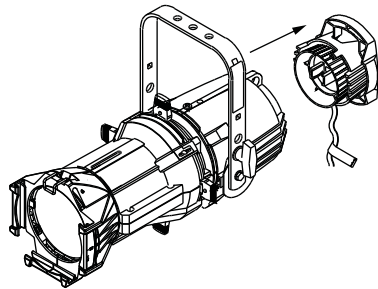

Note: *The burner assembly is no longer needed. If you would like ETC to recycle the burner assembly, contact ETC Technical Services for more information. See "Contacting ETC" on page 5.*

Install Source 4WRD



WARNING: *RISK OF FIRE OR ELECTRIC SHOCK:* Install this kit only to luminaires that have the construction features and dimensions shown in the graphics and where the input rating of the retrofit kit does not exceed the input rating of the luminaire.



WARNING: Do not make or alter any open holes in an enclosure of wiring or electrical components during kit installation.

Step 1: Use oil-free canned air to clean the LED domes prior to installation.



CAUTION: Do not touch or clean LED optic domes with anything other than oil-free canned air.

Step 2: With the fixture resting securely on a flat surface, attach the supplied threaded post to the back end of the fixture body. Use a crescent wrench to tighten the threaded post one-quarter turn past finger tight.

Step 3: Gently slide the Source 4WRD onto the fixture body and threaded post while guiding the LED tower into the lamp housing hole, as shown below.

- Take care to prevent contact between the LEDs and the reflector.

Step 4: Use a #2 Phillips screwdriver to tighten the screw located on the back end of the Source 4WRD, directly above the z-adjustment knob.

Step 5: Pull gently to verify secure attachment.

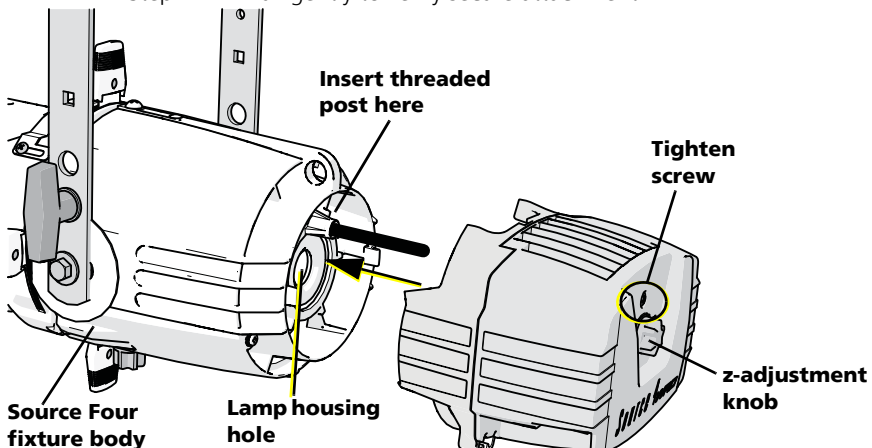

ETC User Manual

Fixture Installation

The Source 4WRD Light Engine combines the classic form factor of the Source Four incandescent fixture with an LED light source. The Source 4WRD Light Engine includes an adjustable yoke, c-clamp, and attached power lead.

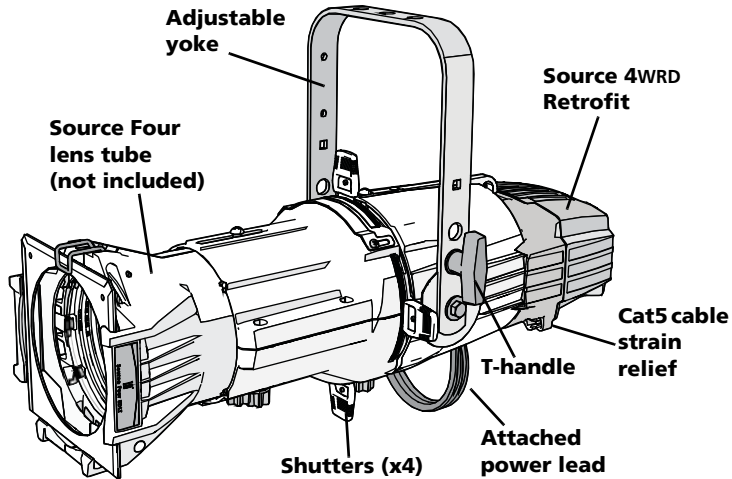

C-clamp and safety cable

The C-clamp attaches the fixture to the mounting pipe and allows you to adjust the position of the mounted fixture. ETC recommends using 1.5" schedule 40 pipe.

- Step 1: Tightly fasten the C-clamp to the yoke with the provided yoke bolt and lock washer.
- Step 2: Place the C-clamp on mounting pipe, then tighten the pipe bolt to secure it.
- Step 3: Loosen the C-clamp pan screw and rotate the yoke to the desired position.
- Step 4: Tighten the pan screw to lock the fixture.
- Step 5: Connect the safety cable.



CAUTION: *Tighten C-clamp pipe bolt to 15-20 ft.lbs. (approximately finger tight plus up to one-quarter turn). Do not exceed 25 ft.lbs. Do not use excessive force.*

Tighten the yoke pivot bolt to 5-10 ft.lbs. (approximately finger tight plus up to one-eighth turn). Do not exceed 15 ft.lbs. Do not use excessive force.

Connect cables

The Source 4WRD can be controlled by AC power or DMX. The fixture responds to the control method selected using the user interface. For more information, see [User Interface](#) on [page 10](#).



Note: Make sure your dimmer is out of regulated mode for optimum performance. Reference [Sensor dimmer settings](#) on [page 3](#) for recommended dimmer settings.

Step 1: If using DMX control, connect RJ45 data cables. One for data-in and one for data-thru, as needed.

- Two strain reliefs are built into the bottom of the Source 4WRD and should be used to support the fixture's data cable.

*To order RJ45 to female XLR adapter, use ETC part# W6538
To order RJ45 to male XLR adapter, use ETC part# W6539*



Note: *Source 4WRD is not self terminating. You must terminate the last fixture in line with a 120 ohm resistor. Please contact your ETC customer service representative to purchase ETC part# N4086.*

DMX pinout

Pin	Description
1	DMX +
2	DMX -
3	Not Connected
4	Not Connected
5	Not Connected
6	Not Connected
7	Iso Common (Shield)
8	Not Connected

- When using DMX over Cat5, use Cat5e or better. Cable distance must not exceed 300m (1000').
- Source 4WRD cannot be controlled via network protocols and should not be connected to a system network.
- Up to 32 fixtures can be connected together into a daisy-chain.



WARNING: **Do not use the Source 4WRD below 5°C (41°F). When the fixture has been stored or transported in freezing temperatures, allow it to warm to room temperature for a minimum of 1 hour prior to applying power. Applying power to a frozen fixture will cause damage to the fixture and void ETC warranty**

Step 2: Connect fixture to power source.

ETC User Manual

User Interface

The two button, seven segment display shows either AC mode or the DMX address.

To set a DMX address: Use the up and down arrows to navigate to the desired DMX address number, 1-512.

To set the fixture to AC mode: Use the down arrow to navigate one number below DMX address #1. The display will read “AC”

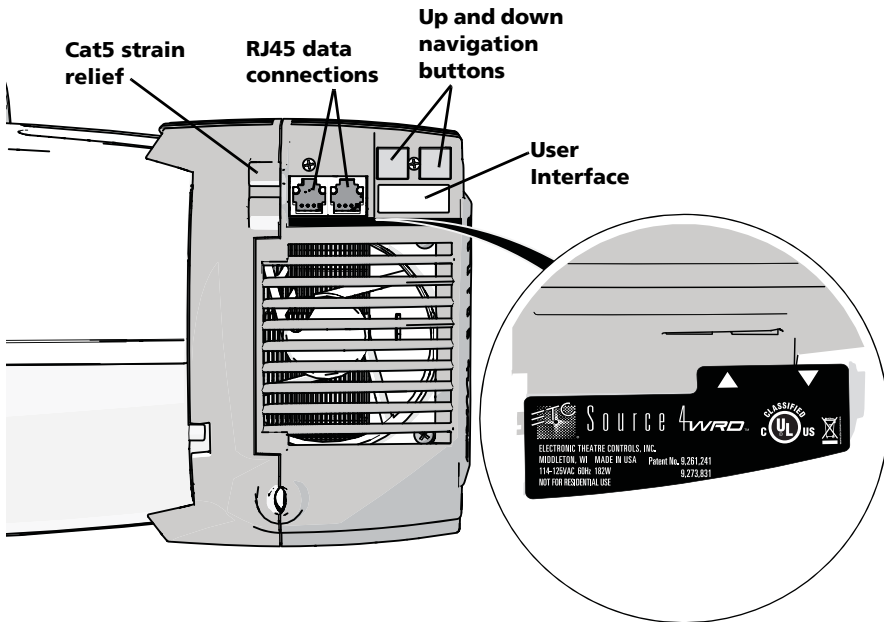

Error codes:

The following error codes may be seen on the Source 4WRD user interface.

OTP -Indicates the fixture has gone into over-temperature protection. Reset the fixture to clear the code.

For DMX mode: return the DMX control to 0.

For AC mode: remove the fixture from power for five seconds and then restore power.

UTP -Indicates the fixture has gone into under-temperature protection. Allow the fixture to warm to a minimum of 5°C (41°F).

Flashing DMX address: Indicates loss of DMX.

Dark screen: Indicates loss of power or fixture time-out. In the event of time-out, press any button to wake the UI.

Focus the fixture

Z-adjustment Knob

The z-adjustment knob located on the rear of the Source 4WRD enables you to adjust the field of the LED light for specific applications.

Adjustment knob

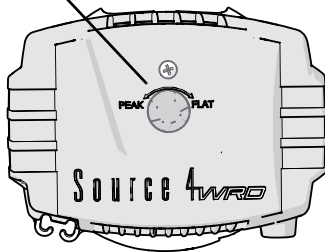

This shows an ideal beam of uniform light



Adjust towards "PEAK" to blend over-lapped beams



Adjust towards "FLAT" to improve sharp focus



- Step 1: Turn on the Source 4WRD and aim it at a flat surface.
- Step 2: Slide the fixture barrel towards or away from the light engine to create a hard-edged beam of light.
- Step 3: Turn the knob toward "Peak" or "Flat" until the desired field is obtained.

Adjust the yoke position

General use position

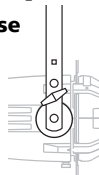

Low clearance position

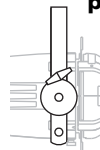

To change the height position:

- Step 1: Remove the yoke locking knobs, washers, and hex bolts from either side of the fixture.
- Step 2: Raise or lower the fixture to the desired position within the yoke.
- Step 3: Reinstall the yoke's hex bolts, washers, and locking knobs.
- Step 4: Tighten the yoke knobs to secure in position.

ETC User Manual

Setting the angle within the yoke

- Step 1: Loosen the yoke locking knobs. **Do not** remove the knobs.
- Step 2: Tilt the fixture to the desired position.
- Step 3: Tighten the yoke locking knobs to secure in position.

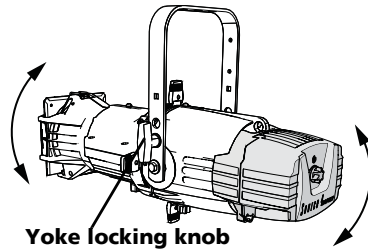

Shape the beam

The beam can be shaped using the shutters, a pattern, an optional drop-in iris, and by rotating the barrel.

Color Frame

The color frame holder is equipped with a spring-loaded retaining clip that prevents color frames and accessories from falling out.

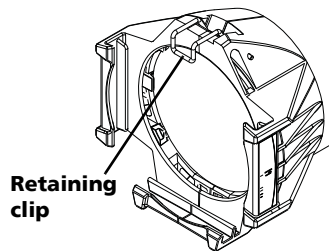

WARNING: Make sure all color frame accessories are locked in position with the retaining clip before hanging the Source 4WRD fixture.

- Step 1: Release the retaining clip by pushing it sideways while gently pulling backwards.
- Step 2: Insert the color frame.
- Step 3: Lock the retaining clip by pushing sideways while gently pushing forward.

Pattern Projection

The pattern holder slot is on the top side of the barrel and in front of the shutters. It accommodates A-size, B-size and glass pattern holders.

A-Size Pattern holder: holds 3" diameter patterns

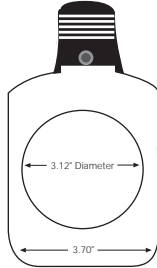

B-Size Pattern holder: holds 2.5" and 2.75" diameter patterns

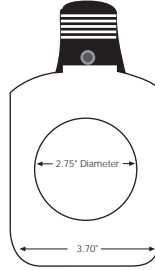

Note:

Because the Source 4WRD aperture is 3 inches wide, ETC recommends using A-size patterns for maximum pattern effectiveness.

Cleaning and Maintenance

Cleaning Source 4WRD

- Use oil-free canned air to clean the LED domes prior to installation and prior to storage.
- Use oil-free canned air to clean the fan and fin stack as part of regular fixture maintenance.
- When not installed on fixture, store the Source 4WRD in its original packaging or in a dust-resistant plastic bag.

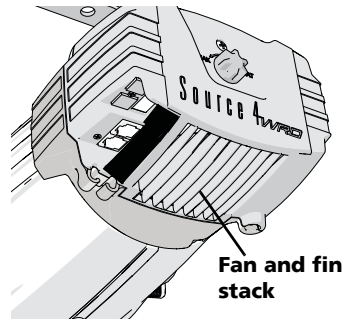

CAUTION: Do not touch or clean LED optic domes with anything other than oil-free canned air.

ETC User Manual

Cleaning Lenses



WARNING: Do not use ammonia-based or other harsh commercial cleaners. Clean lens and reflector only as directed.

Commercially available glass cleaning agents should be avoided as they may contain ammonia, other harsh chemical detergents or abrasive agents. These cleaners may damage the glass surface and the Anti-Reflective coatings. Do not immerse or soak the glass in any cleaning solution.

Replace lenses if they contain visible damage (cracks or deep scratches) that may impair their effectiveness.



Note: *To clean the inside of lenses, it is necessary to remove the lenses from the lens tube for cleaning. Instruction for removing the lens can be found in the Source Four Assembly Guide available for download at www.etcconnect.com*

- Step 1: Remove the lens tube from the fixture barrel:
 - a: Remove the beam focus knob and retainer bolt from the top of the barrel and set aside.
 - b: Slide the lens tube out of the barrel.
 - Step 2: Remove any dust from inside the lens tube with a blast of oil-free air or wipe with a clean, lint-free cloth. Isopropyl alcohol, distilled water or a 50%-50% mixture of each can be used to clean the glass surface.
 - Step 3: Slide the lens tube back into the barrel with the color frame retaining clip on top. Reinstall the beam focus knob and retainer bolt.
-

Cleaning Reflector



WARNING: **Unplug the fixture before attempting to clean the reflector.**

To quickly clean the reflector, remove the lens tube and clean the dust from the reflector with a blast of oil-free air. You may also wipe the reflector with a clean lint-free cloth. If either method is not sufficient, follow these steps.

- Step 1: To protect the lamp housing during cleaning, remove the LED lamp housing by loosening the attachment screw and pulling the housing straight out. (See reverse of [page 7](#))

-
- Step 2: Remove the barrel rotation knob located at the bottom of the barrel. Use a Phillips screwdriver to remove the retainer bolt located on top of the reflector housing.
 - Step 3: Rotate the barrel 45° in either direction. Carefully remove the barrel from the reflector housing.
 - Step 4: Remove dust with a blast of oil-free air or wipe with a clean, lint-free cloth. Isopropyl alcohol, distilled water or a 50%-50% mixture of each can be used to clean the glass surface.
 - Step 5: Insert the barrel into the reflector housing with the iris/pattern slot on top. Align the triangles on both parts.
 - Step 6: While gently pressing in, rotate the barrel 45° clockwise until it sets into position, then rotate the barrel counterclockwise 45°. The barrel should be firmly attached and the triangles should be aligned.
 - Step 7: Reinstall the barrel rotation knob and tighten the retainer bolt.
 - Step 8: Reinstall the LED lamp housing and tighten the attachment screw. See "[Install Source 4WRD](#)" on page 7.

Cleaning 5° and 10° polymer lenses

To quickly clean the lenses, remove dust with a blast of oil-free air. If this is not sufficient, follow these steps.



CAUTION: *Handle polymer lenses by their edges only. Never rub anything dry on a polymer lens.*

- Step 1: Remove the beam focus knob at the bottom of the barrel. Remove the lens tube from the barrel.
- Step 2: Use a Phillips screwdriver to remove the brackets that hold the lens in place. Remove the lens from the tube.
- Step 3: Dip the lens in a clean isopropyl alcohol/water mixture (9 parts water to 1 part isopropyl alcohol).
- Step 4: Use a soft moistened nylon bristle brush to wash the lens' smooth side in a linear (non-circular) motion.
- Step 5: Use the same brush to lightly wash the lens' ridged side by following its ridges.
- Step 6: Dip the lens in a clean isopropyl alcohol/water mixture (9 parts water to 1 part isopropyl alcohol).
- Step 7: Dry the smooth and ridged surfaces with an air gun. Make sure the air flow moves liquid away from you.
- Step 8: Inspect the lens for dirt. Repeat steps 3-7 if necessary.
- Step 9: Set the lens back in the lens tube with the ridged side facing the front of the tube. Reinstall the lens brackets.
- Step 10: Slide the lens tube back into the barrel with gel frame retainer on top. Reinstall beam focus knob.



Corporate Headquarters ■ Middleton, Wisconsin, USA ■ Tel +608 831 4116 ■ Service: (Americas) service@etconnect.com

London, UK ■ Tel +44 (0)20 8896 1000 ■ Service: (UK) service@etceurope.com

Rome, IT ■ Tel +39 (06) 32 111 683 ■ Service: (UK) service@etceurope.com

Holzkirchen, DE ■ Tel +49 (80 24) 47 00-0 ■ Service: (DE) techservhoki@etconnect.com

Hong Kong ■ Tel +852 2799 1220 ■ Service: (Asia) service@etcasia.com

Web: www.etconnect.com ■ Copyright © 2016 ETC. All Rights Reserved.

Product information and specifications subject to change. ■ ETC intends this document to be provided in its entirety.

© 7067M1200-1.0.0 ■ Rev D ■ Released 2016-03