

# INSTRUCTION SHEET

## SIDE-XX-XX

### ESSEX LOCKING SIDE PANEL

#### THANK YOU

Thank you for purchasing the Essex Side-XX-XX Locking Side Panel. Please read these instructions thoroughly before installing this product.

#### TOOLS REQUIRED

- #2 Phillips Screwdriver

#### HARDWARE/ITEMS SUPPLIED

<u>QTY</u>	<u>DESCRIPTION</u>
2	Lock with Locking Clip

#### INSTALLATION

- 1) Engage side panels to mounting holes in rack as shown. **(FIGURE A)**

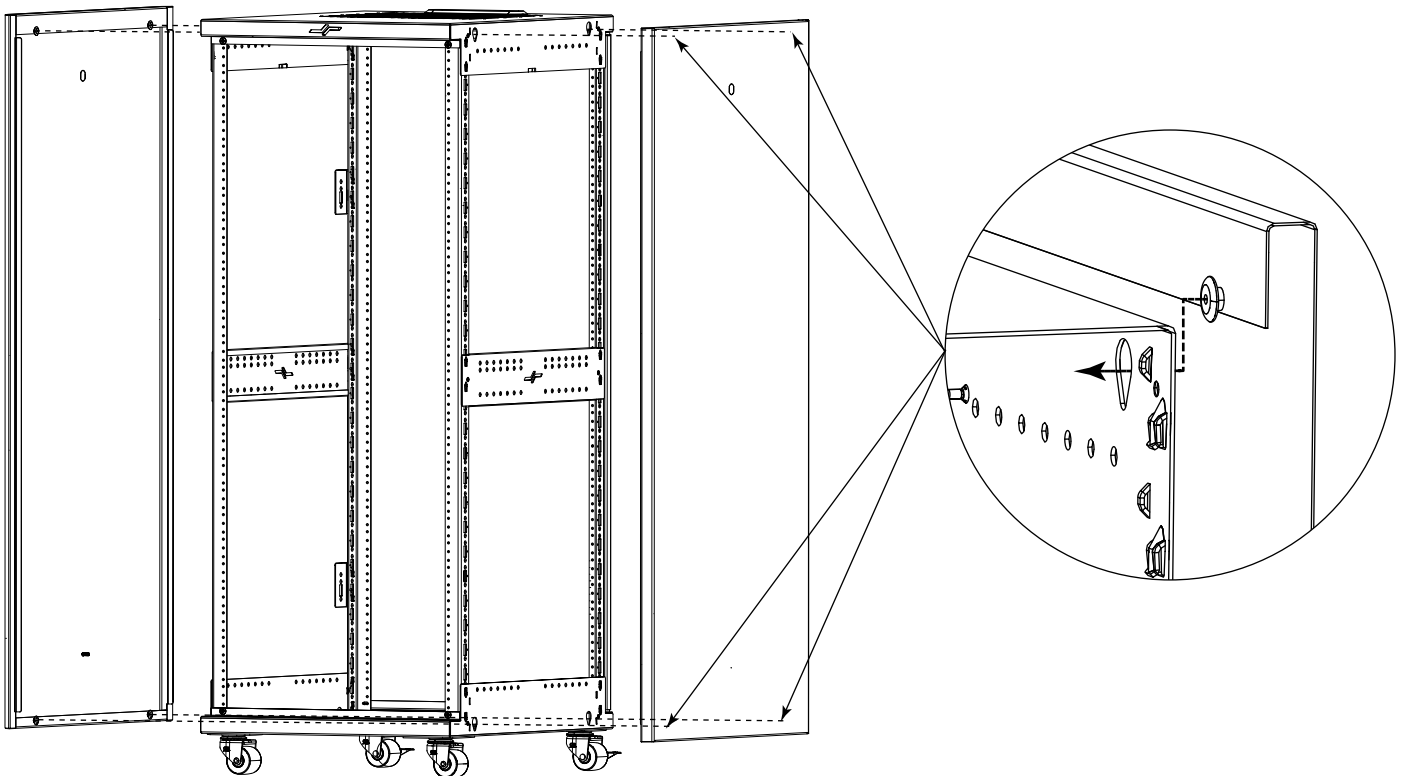

**FIGURE A**

## LOCK INSTALLATION

- 1) Knock out lock hole. **(FIGURE B)**
- 2) Remove screw from lock body.
- 3) Insert lock body into side panel and remove key in a vertical position. **(FIGURE B)**
- 4) Attach lock clip to lock body on inside of side panel as shown. Tap into place to secure lock clip. **(FIGURE C)**

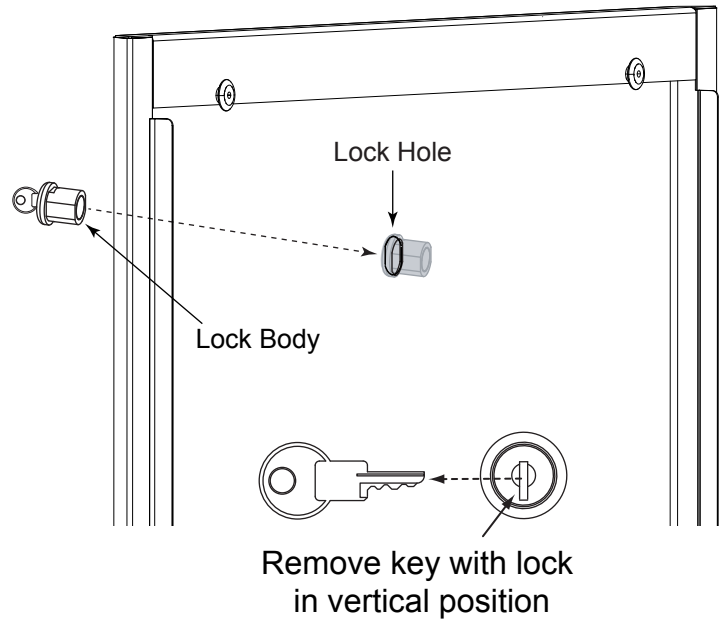

**FIGURE B**

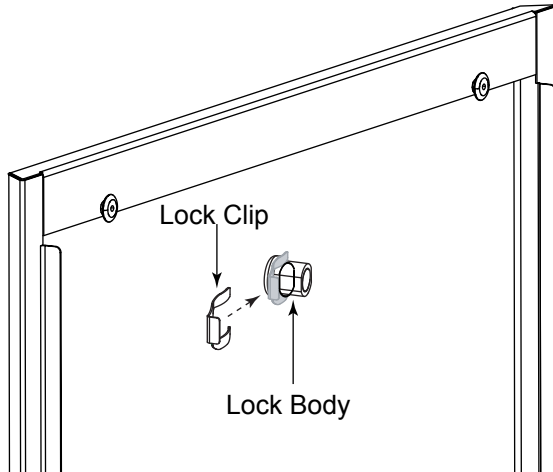

**FIGURE C**

- 5) Attach cam to lock body using supplied screw and tighten. **(FIGURE D)**

**NOTE:** This is the locked position.

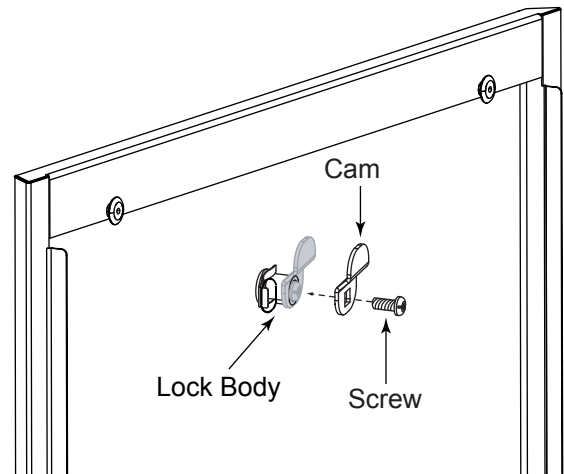

**FIGURE D**

- 6) Install side panel with lock in the unlocked position as shown. **(FIGURE E)**

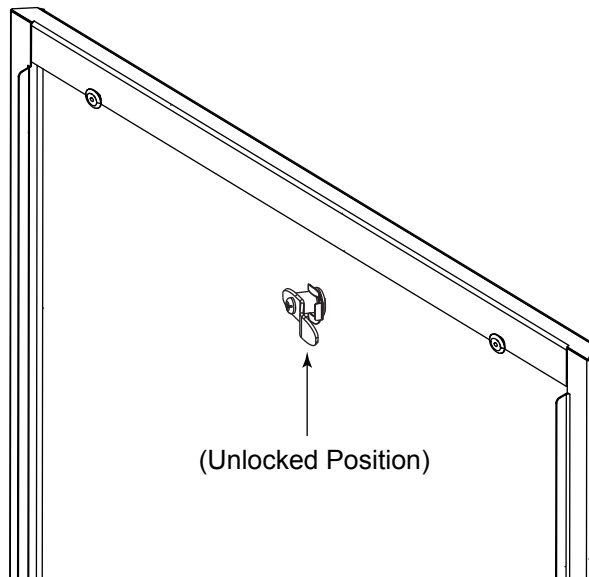
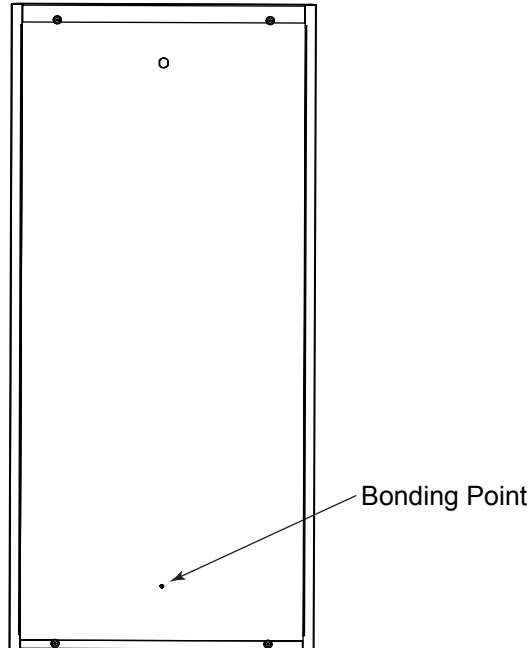

**FIGURE E**

## GROUNDING AND BONDING

Protective Earth Terminals (PET) are located in backpan of the wall rack. These terminals are marked with the symbol . Wall rack parts, center section and door, contain or are provided with bonding points for connection to the backpan / PET. Protective earth and bonding connections shall be in accordance with Article 250 of the National Electric Code.

1) Attach bonding wire to bonding point using hardware kit PET-K-SIDE. **(FIGURE F)**



**FIGURE F**

### WARRANTY

Middle Atlantic Products (the "Company") warrants the ESSEX LOCKING SIDE PANEL to be free from defects in material or workmanship for the lifetime of the product.

The Company's entire liability to the purchaser, and the purchaser's (or any other party's) sole and exclusive remedy, under this warranty shall be limited, at the Company's option, to either (a) return of and refund of the price paid for, or (b) repair or replacement at the Company's factory of the products purchased, or any part or parts thereof, which the Company has determined to be defective after inspection thereof at the Company's factory.

This warranty does not cover damage due to acts of God, accident, misuse, abuse or negligence by parties other than the Company, or any modification or alteration of the products. In addition, this warranty does not cover damage due to improper handling, assembly, installation or maintenance.

THIS WARRANTY IS IN LIEU OF ALL OTHER WARRANTIES OF ANY KIND, EITHER EXPRESSED OR IMPLIED, INCLUDING, BUT NOT LIMITED TO, IMPLIED WARRANTIES OF MERCHANTABILITY AND FITNESS FOR A PARTICULAR PURPOSE.

TO THE MAXIMUM EXTENT PERMITTED BY APPLICABLE LAW, IN NO EVENT SHALL THE COMPANY BE LIABLE FOR ANY SPECIAL, INCIDENTAL, INDIRECT, OR CONSEQUENTIAL DAMAGES WHATSOEVER (INCLUDING, WITHOUT LIMITATION, DAMAGES FOR LOSS OF BUSINESS PROFITS, BUSINESS INTERRUPTION OR ANY OTHER PECUNIARY LOSS) ARISING OUT OF THE USE OF THE PRODUCTS PURCHASED, EVEN IF THE COMPANY HAS BEEN ADVISED OF THE POSSIBILITY OF SUCH DAMAGES. THE COMPANY'S LIABILITY TO THE PURCHASER (OR ANY OTHER PARTY) HEREUNDER, IF ANY, SHALL IN NO EVENT EXCEED THE PURCHASE PRICE OF THE PRODUCTS PAID TO THE COMPANY.

#### Corporate Headquarters

Corporate Voice 973-839-1011 - Fax 973-839-1976 / International Voice +1 973-839-8821 - Fax +1 973-839-4982  
middleatlantic.com - info@middleatlantic.com

#### Middle Atlantic Canada

Voice 613-836-2501 - Fax 613-836-2690 / middleatlantic.ca - customerservicecanada@middleatlantic.ca

#### Factory Distribution

USA: NJ - CA - IL Canada: ON - BC

**At Middle Atlantic Products we are always listening. Your comments are welcome.**

**Middle Atlantic Products is an ISO 9001 and ISO 14001 Registered Company.**