

HD Color Video Camera

Technical Manual



SRG-300SE/SRG-301SE

Table of Contents

- Basic Functions 3**
 - Overview of Functions..... 3
 - Initial Settings and Preset 10
 - Mode Condition 11

- Command List 16**
 - VISCA RS-422 Commands..... 16
 - SRG-300SE/SRG-301SE Commands 22

- Other 39**

Basic Functions

Overview of Functions

Zoom

The SRG camera employs a 30× optical zoom lens combined with a digital zoom function; this camera allows you to zoom up to 360×.

- **Optical 30×, f = 4.3 mm to 129 mm (F 1.6 to F 4.7)**

Digital Zoom enlarges the center of the subject by expanding each image in both the vertical and horizontal directions. When the digital zoom is used, the resolution deteriorates.

You can activate the zoom in the following modes, all of which can be set using VISCA command.

Standard Mode

Variable Mode

There are eight levels of zoom speed.

In these standard and variable modes, it is necessary to send Stop Command to stop the zoom operation.

Direct Mode

Setting the zoom position enables quick movement to the designated position.

Digital Zoom ON/OFF

Focus

Focus has the following modes, all of which can be set using VISCA Commands.

- **Auto Focus Mode**

The Auto Focus (AF) function automatically adjusts the focus position to maximise the high frequency content of the picture in a center measurement area, taking into consideration the high luminance and strong contrast components.

The minimum focus distance is 10 mm at the optical wide end and 1200 mm at the optical tele end.

- **Normal AF Mode**

This is the normal mode for AF operations.

- **Interval AF Mode**

The mode used for AF movements carried out at particular intervals. The time intervals for AF movements and for the timing of the stops can be set in one-second increments using the Set Time Command. The initial value for both is set to five seconds.

- **Zoom Trigger Mode**

When the zoom is changed, the AF mode activates for the pre-set time. Then, it stops. The initial value is set to 5 seconds.

AF sensitivity can be set to either Normal or Low.

- **Normal**

Reaches the highest focus speed quickly. Use this when shooting a subject that moves frequently. Usually, this is the most appropriate mode.

- **Low**

Improves the stability of the focus. When the lighting level is low, the AF function does not take effect, even though the brightness varies, contributing to a stable image.

- **Manual Focus Mode**

Manual Focus has both a Standard Mode and a Variable Mode. Standard Mode focuses at a fixed rate of speed. Variable Mode has eight speed levels that can be set using a VISCA Command.

In these standard and variable modes, it is necessary to send Stop Command to stop the zoom operation.

- **One Push Trigger Mode**

When a Trigger Command is sent, the lens moves to adjust the focus for the subject. The focus lens then holds that position until the next Trigger Command is input.

- **Infinity Mode**

The lens is forcibly moved to a position suitable for an unlimited distance.

- **Near Limit Mode**

Can be set in a range from 1000 (∞) to F000 (1 cm). Default setting: D000h (30 cm)

White Balance

White Balance has the following modes.

- **Auto White Balance**

This mode computes the white balance value output using color information from the entire screen. It outputs the proper value using the color temperature radiating from a black subject based on a range of values from 2500K to 7500K.

This mode is the factory setting.

- **ATW**

Auto Tracing White balance (2000K to 10000K)

- **Indoor**

3200K Base Mode

- **Outdoor**

5800K Base Mode

- **One Push WB**

One Push White Balance is a function that forcibly captures the white color once the lighting conditions to illuminate the subject are set, enabling you to shoot the image in the conditions as they are set. By using this function, the natural color of the subject can be obtained without being affected by the surrounding lighting conditions. To set this mode, shoot the subject that you want to capture the white color and send the One Push White Balance Trigger.

- **Manual WB**

Manual control of R and B gain, 256 steps each

Automatic Exposure Mode

A variety of AE functions are available for optimal output of subjects in lighting conditions that range from low to high.

- **Full Auto**

Iris, Gain and Shutter Speed can be set automatically.

- **Gain Limit Setting**

The gain limit can be set at the Full Auto, Shutter Priority, Iris Priority, Bright and Manual in the AE mode. Use this setting when image signal-to-noise ratio is particularly important.

- **Shutter Priority¹⁾**

Variable Shutter Speed, Auto Iris and Gain (1/1 to 1/10,000 sec., 16 high-speed shutter speeds plus 6 low-speed shutter speeds)

1) Flicker can be eliminated by setting shutter to

→ 1/100s for NTSC models used in countries with a 50 Hz power supply frequency

→ 1/120s for PAL models used in countries with a 60 Hz power supply frequency

- **Iris Priority**

Variable Iris (F1.6 to Close, 14 steps), Auto Gain and Shutter speed

- **Manual**

Variable Shutter, Iris and Gain

- **Bright**

Variable Iris and Gain (Close to F1.6, 14 steps and F1.6 at 15 steps)

AE – Shutter priority

The shutter speed can be set freely by the user to a total of 22 steps – 16 high speeds and 6 low speeds. When the slow shutter is set, the speed can be adjusted the slow shutter according to subject brightness. The picture output is read at a low rate from the memory. AF capability is low.

In high speed mode, the shutter speed can be set up to 1/10,000s. The iris and gain are set automatically, according to the brightness of the subject.

Parameter	59.94/29.97 mode	50/25 mode
15	1/10000	1/10000
14	1/6000	1/6000
13	1/4000	1/3500
12	1/3000	1/2500
11	1/2000	1/1750
10	1/1500	1/1250
0F	1/1000	1/1000
0E	1/725	1/600
0D	1/500	1/425
0C	1/350	1/300
0B	1/250	1/215
0A	1/180	1/150
09	1/125	1/120
08	1/100	1/100
07	1/90	1/75
06	1/60	1/50
05	1/30	1/25
04	1/15	1/12
03	1/8	1/6
02	1/4	1/3
01	1/2	1/2
00	1/1	1/1

AE – Iris priority

The iris can be set freely by the user to 14 steps between F1.6 and Close.

The gain and shutter speed are set automatically, according to the brightness of the subject.

Parameter	Setting value	Parameter	Setting value
11	F1.6	0A	F5.6
10	F2	09	F6.8
0F	F2.4	08	F8
0E	F2.8	07	F9.6
0D	F3.4	06	F11
0C	F4	05	F14
0B	F4.8	00	CLOSE

AE – Manual

The shutter speed (22 steps), iris (14 steps) and gain (15 steps) can be set freely by the user.

AE – Bright

The bright control function adjusts both gain and iris using an internal algorithm, according to a brightness level freely set by the user. Exposure is controlled by gain when dark, and by iris when bright.

As both gain and iris are fixed, this mode is used when exposing at a fixed camera sensitivity. When switching from Full Auto or Shutter Priority Mode to Bright Mode, the current status will be retained for a short period of time.

Only when the AE mode is set to “Full Auto” or “Shutter Priority,” you can switch it to “Bright.”

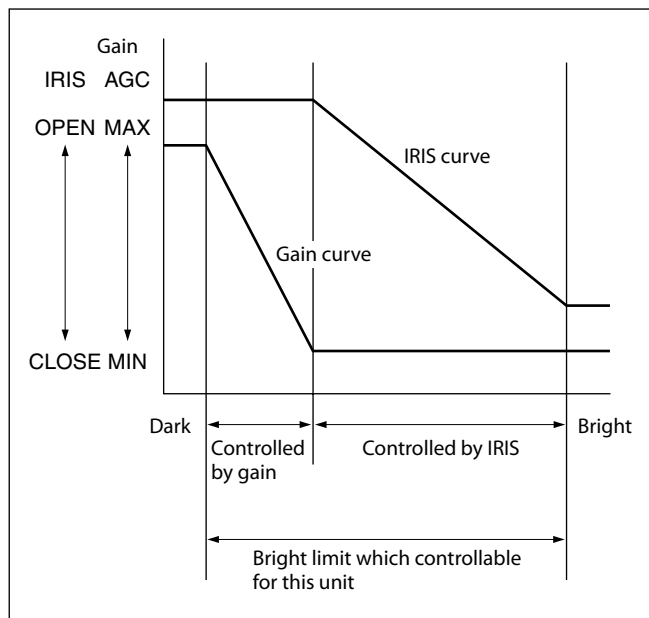

Parameter	Iris	Gain	Parameter	Iris	Gain
1F	F1.6	+43 dB	11	F1.6	0 dB
1E	F1.6	+39 dB	10	F2	0 dB
1D	F1.6	+36 dB	0F	F2.4	0 dB
1C	F1.6	+33 dB	0E	F2.8	0 dB
1B	F1.6	+30 dB	0D	F3.4	0 dB
1A	F1.6	+27 dB	0C	F4	0 dB
19	F1.6	+24 dB	0B	F4.8	0 dB
18	F1.6	+21 dB	0A	F5.6	0 dB
17	F1.6	+18 dB	09	F6.8	0 dB
16	F1.6	+15 dB	08	F8	0 dB
15	F1.6	+12 dB	07	F9.6	0 dB
14	F1.6	+9 dB	06	F11	0 dB
13	F1.6	+6 dB	05	F14	0 dB
12	F1.6	+3 dB	00	CLOSE	0 dB

When switching from the Shutter Priority mode to the Bright mode, the shutter speed set in the Shutter Priority mode is maintained.

Defog mode

When the surrounding area of the subject is foggy and low contrast, the defog mode will make the subject appear clearer.

Wide Dynamic Range Mode (WD)

The Wide Dynamic Range mode is a function for dividing an image into several blocks and correcting blocked-up shadows and blown-out highlights in accordance with the intensity difference. It enables you to obtain images in which portions ranging from dark to light can be recognized, even when capturing a subject with a large intensity difference that is backlit or includes extremely light portions.

Images with wide dynamic range are produced by combining long-exposure signals (normal shutter) with the signals of the high-intensity portions obtained with a short exposure (high-speed shutter).

• About WD Set Parameter

(Command: 8x 01 7E 04 00 0p FF)

p: WIDE D (Wide dynamic range mode)

When MODE (exposure mode) is set to FULL AUTO, the camera distinguishes light and dark areas in the same scene, adjusts the brightness for dark areas, and also controls the blown out highlights.

You can select the wide dynamic range mode from among OFF, LOW, MID and HIGH. (0: OFF, 1: LOW, 2: MID, 3: HIGH.)

Notes

- You can set the wide dynamic range mode when the WIDE D is set to FULL AUTO only.
- When the WIDE D is not set to OFF, the MODE setting is fixed at FULL AUTO.
- When changing the WIDE D, the luminance change of the screen occurs for a moment.
- When the change of exposure is big, the screen may stop for a moment.
- When the wide dynamic range mode is ON, false colors may appear in some parts of the image. This phenomenon is unique to wide dynamic range mode, and is not an indication of a camera malfunction.
- When switching wide dynamic range mode, images are shown at a maximum of 8 frames at the same time.
- When the intensity difference of the image is small, there is no difference in effect between MID and HIGH.

Exposure Compensation

Exposure compensation is a function which offsets the internal reference brightness level used in the AE mode, by steps of 1.5 dB.

The reference brightness is 0.

Parameter	Step	Setting value
0E	+7	+10.5 dB
0D	+6	+9 dB
0C	+5	+7.5 dB
0B	+4	+6 dB
0A	+3	+4.5 dB
09	+2	+3 dB
08	+1	+1.5 dB
07	0	0 dB
06	-1	-1.5 dB
05	-2	-3 dB
04	-3	-4.5 dB
03	-4	-6 dB
02	-5	-7.5 dB
01	-6	-9 dB
00	-7	-10.5 dB

High Resolution Mode

This mode enhances edges and produces higher definition images.

Aperture Control

Aperture control is a function which adjusts the enhancement of the edges of objects in the picture. There are 16 levels of adjustment, starting from “no enhancement.” When shooting text, this control may help by making them sharper.

Back Light Compensation

When the background of the subject is too bright, or when the subject is too dark due to shooting in the AE mode, back light compensation will make the subject appear clearer.

Noise Reduction

The NR (Noise Reduction) function removes noise (both random and non-random) to provide clearer images.

This function has six steps: levels 1 to 5, plus off.

The NR effect is applied in levels based on the gain, and this setting value determines the limit of the effect. In bright conditions, changing the NR level will not have an effect.

High Sensitivity Mode

In this mode, higher sensitivity gain is applied as standard gain increases, reaching a gain level at MAX gain of up to 4x the standard gain. In such cases, however, there will be a high volume noise in the image.

Gamma Mode

In this mode, the gamma can be set to ON/OFF.

0: Standard

1: OFF

Image Stabilizer

You can set this function to ON or OFF. When set to ON, you can obtain steadier images if vibration is present. This stabilizer is effective for vibration frequencies around 10 Hz. This function utilizes digital zoom; therefore, the angle of view and resolution of images may be affected. However, image sensitivity is retained.

OFF: The image stabilizer function is not effective operations.

ON: The image stabilizer function is effective operations.

Notes

- The image stabilizer function is not effective during pan/tilt operations. It may take some time for the image to stabilize after performing pan/tilt operations.
- If the image stabilizer function is enabled, it may take some time for the image to stabilize after turning on the power of the camera.
- Depending on the installation conditions, the image stabilizer may not be effective.
- When the image stabilizer function is set to ON, the field angle is shifted to the direction in which the subject appears larger.
- The image stabilizer may not be effective in an installation environment where high frequency vibration is present. In this case, set the image stabilizer function to OFF.

Auto Slow Shutter On/Off

When set to “On,” the slow shutter functions automatically when the light darkens. This setting is available only when the AE mode is set to “Full Auto.” The default setting is “Auto Slow Shutter Off.”

Low-Illumination Chroma Suppress Mode

You can configure a chroma suppress mode for low-illumination conditions. This can be useful when color noise is particularly noticeable in such conditions. Four levels (disabled and three levels) are available for the low-illumination chroma suppress mode.

ICR (IR Cut-Removable) Mode

The IR Cut-Filter can be disengaged, by which the sensitivity in the infrared range is increased, allowing the camera to capture the image in darker area. When the auto ICR mode is set to ON, the image becomes black and white.

Color Gain

You can configure the color gain. Use this setting when bright color is particularly important.

The initial setting 100% (4h) can be set to range from approx. 60% (0h) to 200% (Eh) with 15 stages.

Color Phase

You can configure green, yellow, red, magenta, blue and cyan individually.

The initial setting 0 degrees (7h) is adjustable between approx. -14 degrees (0h) to +14 degrees (Eh), in 15 increments.

Auto ICR Mode

Auto ICR Mode automatically switches the settings needed for attaching or removing the IR Cut Filter. With a set level of darkness, the IR Cut Filter is automatically disabled (ICR ON), and the infrared sensitivity is increased. With a set level of brightness, the IR Cut Filter is automatically enabled (ICR OFF). Also, on systems equipped with an IR light, the internal data of the camera is used to make the proper decisions to avoid malfunctions.

Auto ICR Mode operates with the AE Full Auto setting.

When Auto Slow Shutter is Off (initial setting)

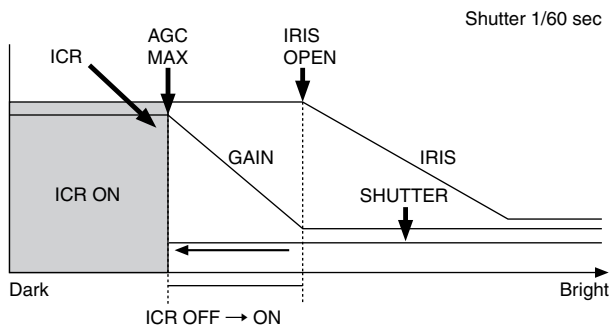

When Auto Slow Shutter is On

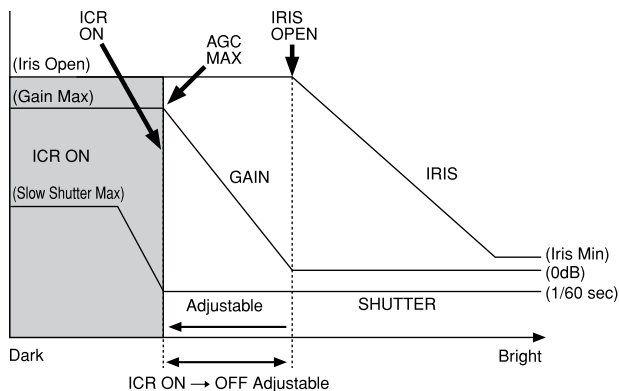

Note

Depending on the information such as brightness, etc., in the ON/OFF settings condition, a malfunction may occur when the subjects largely consisting of blue and green colors are taken.

Camera ID

The ID can be set up to 65,536 (0000 to FFFF). As this will be memorized in the nonvolatile memory inside, data will be saved.

Picture Effect

It consists of the following functions.

- **Neg. Art:** Negative/Positive Reversal
- **Black & White:** Monochrome Image

Others

I/F Clear

Clears the Command buffer of the camera.

The buffer is cleared even during the power on state using the control software.

Address Set

VISCA is a protocol, which supports a daisy chain of up to seven connected cameras via RS-422 interface. In such cases, the address set command can be used to assign addresses from 1 to 7 to each of the seven cameras, allowing you to control the seven cameras with the same personal computer. Be sure to use the address set command to set the address whenever a camera is connected for the first time.

Memory (Preset)

Using the preset function, 16 sets of camera shooting conditions can be stored and recalled.

This function allows you to achieve the desired status instantly, even without adjusting the following items each time.

- **Pan/Tilt Position**
- **Zoom Position**
- **Digital Zoom On/Off**
- **Focus Mode Auto/Manual**
- **Focus Position**
- **Exposure mode**
- **Shutter speed**
- **Bright Level**
- **Iris**
- **Gain**
- **Exposure Compensation**
- **Exposure Compensation Value**
- **Backlight Compensation On/Off**
- **Auto Slow Shutter On/Off**
- **White Balance Mode**
- **Aperture Value**
- **Day/Night ICR function status**
- **WDR (View-DR)**

The settings stored using this function are recalled when the power is turned on.

For setting items, see the “Initial Settings and Preset” section on page 10.

Note

Rewriting of memory is not unlimited. Be careful to avoid using the memory area for such as unnecessary tasks as rewriting the contents of the memory for every operation.

Initial Settings and Preset

- The initial values are the factory settings.
- When you send the CAM Memory Reset command, the selected number is set as initial value.
- The preset 1 is the CAM Memory number “0” in the VISCA command. The preset 2 to 16 are the CAM Memory number “1 to 15” in the VISCA command.

Items stored to presets	Initial settings	Preset position number	
		1 to 16	17 to 256*
Pan/Tilt Position	Home position	○	○
Zoom Position	Wide end	○	○
Focus Mode Auto/Manual	Auto	○	—
Focus Position	—	○	○
Backlight Compensation ON/OFF	Off	○	—
Exposure mode	Full Auto	○	—
WDR (View-DR)	Off	○	—
Auto slow shutter	Off	○	—
Bright level	—	○	—
Shutter speed	—	○	—
Iris	—	○	—
Gain	—	○	—
Exposure compensation	Off	○	—
Exposure compensation value	±0	○	—
White balance mode	Auto	○	—
Aperture value	8	○	—
Digital zoom On/Off	On	○	—
Day/Night ICR function status	Off	○	—

* The settings of preset numbers 17 to 256 are available for the setting via a network only.

○ Setting items retained in the memory when the power is turned off and then on again.

— Setting items cleared from the memory when the power is turned off and then on again.

Items stored when operating the camera

- Gain limit value
- High resolution mode
- Noise reduction
- Mode of the Day/Night ICR function
- Image stabilizer
- Pan-Tilt limit
- Slow Pan-Tilt mode
- DISPLAY INFO

- The setting items other than the above mentioned are retained when they are enabled in each tab of the menus with the operation via a network.
- The stored and retained setting items are retained in the memory when the power is turned off and then on again.
- The camera starts with the settings stored in POSITION 1 and the settings stored when last operated when the power is turned on.

Notes

- The execution of memory to the preset is limited.
- The setting or deleting of memory to/from POSITION1 takes approx. 2 seconds longer than other channels.
- In CameraID, the data is stored regardless of the preset.
- When ImageFlip is executed, all presets are reset to the initial value.

Mode Condition

With SRG-300SE, you can perform control via CGI and VISCA. If control is executed via VISCA while executing control via CGI, NotExe is returned. The inquiry commands can be executed even if the CGI control is being executed.

Basic settings

Command	Mode	IFC ¹⁾	Initializing ²⁾	During displaying the menu	Memory Command	OnePushWB	VideoFormatChange	Pan-TiltReset
Address Set		Yes	Yes	Yes	Yes	Yes	Yes	Yes
IF_Clear		Yes ⁵⁾	Yes ⁵⁾	Yes ⁵⁾	Yes ⁵⁾	Yes ⁵⁾	Yes ⁵⁾	Yes ⁵⁾
CAM_VersionInq		Yes	Yes ³⁾	Yes	Yes	Yes	Yes	Yes
CAM_PowerInq		Yes	Yes	Yes	Yes	Yes	Yes	Yes
InquiryCommand		No	No	Yes ⁴⁾	No	No	No	Yes

- 1) The period from the time IF Clear is sent, until the Reply Packet is returned.
- 2) The period from the time DC power is turned on, the camera subsequently finishes the pan/tilt reset operation, and stops at the Home position until the video signal is output.
- 3) Commands can be executed after the pan/tilt movement has been started. Before that, camera movement may be inconsistent.
- 4) When the menu display is updating, operation is not possible.
- 5) Although the command is received, it is not executed.

Zoom/Focus

Command	Mode	IFC ¹⁾	Initializing ²⁾	Zoom Direct	Focus Direct	AF ON	During displaying the menu	Memory Recall
CAM_Zoom Tele/Wide/Stop [VISCA]		No	No	No	Yes	Yes	Yes ³⁾	No
CAM_Zoom Direct		No	No	Yes	Yes	Yes	Yes ³⁾	No
D-Zoom Limit		No	No	No	Yes	Yes	Yes ³⁾	No
CAM_Focus Far/Near/Stop [VISCA]		No	No	Yes	No	No	Yes ³⁾	No
CAM_Focus Direct		No	No	Yes	Yes	No	Yes ³⁾	No
CAM_Focus Mode (Auto/Manual)		No	No	Yes	No	Yes	Yes ³⁾	No
CAM_Focus One Push Trigger		No	No	Yes	No	No	Yes ³⁾	No
CAM_Focus Infinity		No	No	Yes	No	Yes	Yes ³⁾	No
CAM_Focus Near Limit		No	No	Yes	No	Yes	Yes ³⁾	No
AF Sensitivity Normal/Low		No	No	Yes	Yes	Yes	Yes ³⁾	No
AF Mode Norm/Interval/Zoom		No	No	Yes	Yes	Yes	Yes ³⁾	No
AF Activation Time/Interval Setting		No	No	Yes	Yes	Yes	Yes ³⁾	No

- 1) The period from the time IF Clear is sent, until the Reply Packet is returned.
- 2) The period from the time DC power is turned on, the camera subsequently finishes the pan/tilt reset operation, and stops at the Home position until the video signal is output.
- 3) When the menu display is updating, operation is not possible.

White Balance

Command	Mode	IFC ¹⁾	Initializing ²⁾	White balance mode				During displaying the menu	Memory Recall
				Auto					
				Indoor	Outdoor	One Push	ATW		
CAM_WB Auto/Indoor/Outdoor/OnePushWB/Manual/ATW		No	No	Yes	Yes	Yes	Yes	Yes ³⁾	No
CAM_WB One Push Trigger		No	No	No	No	Yes ⁴⁾	No	Yes ³⁾	No
CAM_WB R(B) Gain Reset/Up/Down/Direct		No	No	No	No	No	Yes	Yes ³⁾	No

- 1) The period from the time IF Clear is sent, until the Reply Packet is returned.
- 2) The period from the time DC power is turned on, the camera subsequently finishes the pan/tilt reset operation, and stops at the Home position until the video signal is output.
- 3) When the menu display is updating, operation is not possible.
- 4) Commands are ignored during a One Push AWB operation.

Exposure

Command	Mode	IFC ¹⁾	Initializing ²⁾	Exposure mode					During displaying the menu	Memory Recall
				Full Auto WIDE D Off	Full Auto WIDE D Low/Mid/High	Bright	Shutter Pri	Iris Pri		
CAM_AE		No	No	Yes	No	Yes ³⁾	Yes	Yes	Yes ⁴⁾	No
Full Auto/Manual/Shutter Pri/Iris Pri/Spot Light		No	No	Yes	No	Yes	Yes	No	Yes ⁴⁾	No
CAM_AE Bright		No	No	Yes	No	Yes	Yes	Yes	Yes ⁴⁾	No
CAM_Slow Shutter Limit ON/OFF		No	No	Yes	No	Yes	Yes	Yes	Yes ⁴⁾	No
CAM_Shutter Reset/Up/Down/Direct		No	No	No	No	No	Yes	Yes	Yes ⁴⁾	No
CAM_Iris Reset/Up/Down/Direct		No	No	No	No	No	No	Yes	Yes ⁴⁾	No
CAM_Gain Reset/Up/Down/Direct		No	No	No	No	No	No	Yes	Yes ⁴⁾	No
CAM_Bright/Up/Down/Direct		No	No	No	No	Yes	No	No	Yes ⁴⁾	No
CAM_ExComp On/Off		No	No	Yes	Yes	Yes	Yes	Yes	Yes ⁴⁾	No
CAM_ExComp Reset/Up/Down/Direct ⁵⁾		No	No	Yes	Yes	Yes	Yes	Yes	Yes ⁴⁾	No
CAM_Backlight On/Off		No	No	Yes	Yes	No	No	No	Yes ⁴⁾	No
CAM_WIDE D Off/Low/Mid/High		No	No	Yes	Yes	No	No	No	Yes ⁴⁾ ⁶⁾	No
CAM_Defog		No	No	Yes	Yes	No	No	No	Yes ⁶⁾	No

1) The period from the time IF Clear is sent, until the Reply Packet is returned.

2) The period from the time DC power is turned on, the camera subsequently finishes the pan/tilt reset operation, and stops at the Home position until the video signal is output.

3) Yes: Only when the camera changes to BRIGHT mode from Full Auto or SHUTTER Pri mode.

4) When the menu display is updating, operation is not possible.

5) No: This is not allowed when EX-COMP is set to OFF.

6) This can be changed only when the exposure control mode is Full Auto.

Effect

Command	Mode	IFC ¹⁾	Initializing ²⁾	During displaying the menu	Memory Recall
CAM_Aperture Reset/Up/Down/Direct		No	No	Yes ³⁾	No
Display info. (ON/OFF)		No	No	Yes ³⁾	No
CAM_PictureEffect OFF/Neg.Art/B&W		No	No	Yes ³⁾	No
CAM_ICR ON/OFF		No	No	Yes ³⁾	No
CAM_AutoICR ON/OFF/Threshold		No	No	Yes ³⁾	No
CAM_HR ON/OFF		No	No	Yes ³⁾	No
CAM_NR		No	No	Yes ³⁾	No
CAM-ChromaSuppress		No	No	Yes ³⁾	No
CAM_ColorGain		No	No	Yes ³⁾	No
CAM_ColorHue		No	No	Yes ³⁾	No

- 1) The period from the time IF Clear is sent, until the Reply Packet is returned.
- 2) The period from the time DC power is turned on, the camera subsequently finishes the pan/tilt reset operation, and stops at the Home position until the video signal is output.
- 3) When the menu display is updating, operation is not possible.

Pan/Tilt

Mode	Pan/Tilt normal status										
	IFC ¹⁾	Initializing ²⁾	Zoom (Direct)	Focus (Direct)	Pan/tilt movement according to the command ³⁾	Absolute Position execution	Relative Position execution	Home execution	Reset execution	Memory Recall	During displaying the menu
Command	Pan-tiltDrive Up/Down/Left/Right/UpLeft/UpRight/DownLeft/DownRight	No	Yes	Yes	Yes	No	No	No	No	No	No
	Pan-tiltDrive Stop	No	Yes	Yes	Yes	Yes	No	No	No	No	No
Pan-tiltDrive AbsolutePosition	Pan-tiltDrive AbsolutePosition	No	Yes	Yes	Yes	Yes	No	No	No	No	Yes ⁴⁾
	Pan-tiltDrive RelativePosition	No	Yes	Yes	Yes	No	No	No	No	No	Yes ⁴⁾
Pan-tiltDrive Home	Pan-tiltDrive Home	No	Yes	Yes	Yes	No	No	Yes	No	No	No
	Pan-tiltDrive Reset	No	Yes	Yes	Yes	No	No	No	No	No	No
Pan-tiltLimitSet	Pan-tiltLimitSet LimitSet	No	Yes	Yes	Yes	Yes	No	No	No	No	Yes ⁴⁾
	Pan-tiltLimitSet LimitClear	No	Yes	Yes	Yes	Yes	No	No	No	No	Yes ⁴⁾
Memory Set	Memory Set	No	No	No	No	No	No	No	No	No	No
	Memory Reset	No	No	No	No	No	No	No	No	No	No
Memory Recall	Memory Recall	No	No ⁵⁾	No ⁶⁾	No ⁶⁾	No	No	No	No	Yes	No
		No	No ⁵⁾	No ⁶⁾	No ⁶⁾	No	No	No	No	Yes	No

- 1) The period from the time IF Clear is sent, until the Reply Packet is returned.
- 2) The period from the time DC power is turned on, the camera subsequently finishes the pan/tilt reset operation, and stops at the Home position until the video signal is output.
- 3) The pan/tilt operation works by Pan-tiltDrive Up/Down/Left/Right/UpLeft/UpRight/DownLeft/DownRight commands.
- 4) When the menu display is updating, operation is not possible.
- 5) Yes: while the camera operates in Tele/Wide zoom mode.
- 6) Yes: while the camera operates in Far/Near focus mode.

Command List

VISCA¹⁾ RS-422 Commands

Use of RS-422 control software based upon this command list may cause malfunction or damage to hardware and software. Sony Corporation is not liable for any such damage.

Overview of VISCA

In VISCA, the device outputting the commands, for example, a computer, is called the controller, while the device receiving the commands, such as this unit, is called the peripheral device. In VISCA, up to seven peripheral devices can be connected to one controller using communication conforming to the RS-422 standard. The parameters of RS-422 are as follows.

- Communication speed: 9600 bps/38400 bps
- Data bits : 8
- Start bit : 1
- Stop bit : 1
- Non parity

Flow control using XON/XOFF and RTS/CTS, etc., is not supported.

Peripheral devices are connected in a daisy chain. As shown in Fig. 1, the actual internal connection is a one-direction ring, so that messages return to the controller via the peripheral devices. The devices on the network are assigned addresses.

The device address is assigned to each device on the network. The address of the controller is fixed at 0.

Each VISCA equipment has VISCA IN and VISCA OUT connectors.

Set the DTR input (the S output of the controller) of VISCA IN to H when controlling VISCA equipment from the controller.

Note

When connecting in a daisy chain using this unit, set the BAUD RATE correctly.

In case that any device having different setting is connected in a daisy chain, the devices do not operate correctly.

Fig. 1 VISCA daisy chain connection

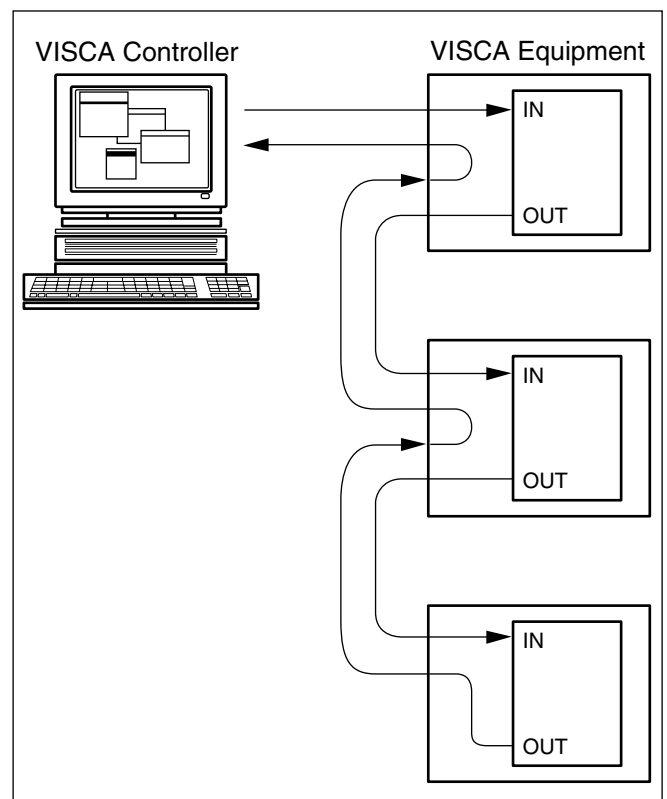

¹⁾ VISCA is a protocol developed by Sony for controlling a consumer's camcorder. "VISCA" is a trademark of Sony Corporation.

VISCA Communication Specifications

VISCA packet structure

The basic unit of VISCA communication is called a packet (Fig. 2). The first byte of the packet is called the header and comprises the sender's and receiver's addresses. For example, the header of the packet sent to the SRG assigned address 1 from the controller (address 0) is 81h in hexadecimal. The packet sent to the SRG assigned address 2 is 82h. In the command list, as the header is 8X, input the address of the SRG to X. The header of the reply packet from the SRG assigned address 1 is 90h. The packet from the SRG assigned address 2 is A0h.

Some of the setting commands for SRG can be sent to all devices at one time (broadcast). In the case of broadcast, the header should be 88h in hexadecimal.

When the terminator is FFh, it signifies the end of the packet.

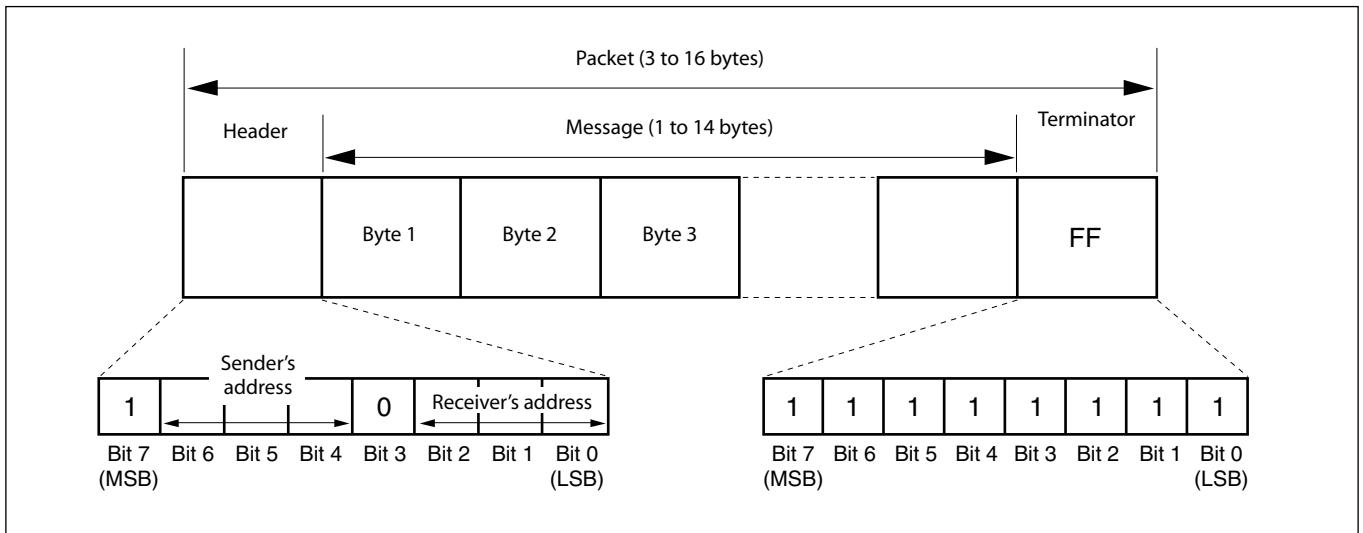

Fig. 2 Packet structure

Note

Fig. 2 shows the packet structure, while Fig. 3 shows the actual waveform. Data flow will take place with the LSB first.

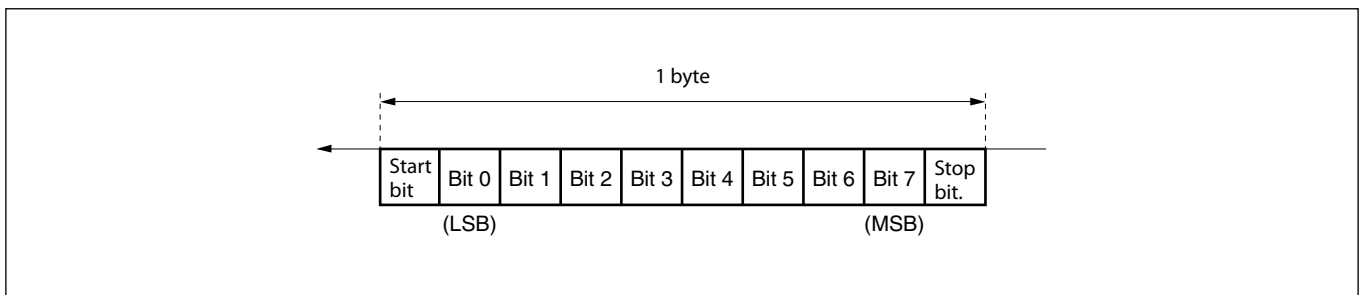
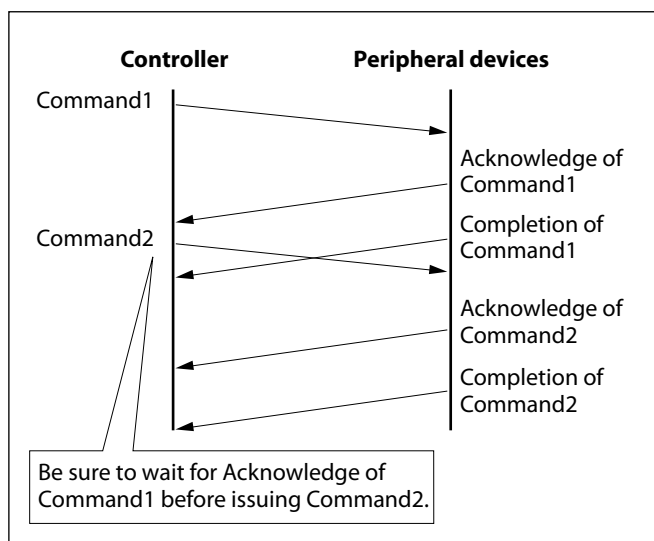

Fig. 3 Actual waveform for 1 byte.

Timing Chart

If two or more commands are to be sent successively, wait for a reply command (an Acknowledge or error message for a general command, and an inquiry packet for an inquiry command) of the previous command to be received before sending the next command.



Command and inquiry

● Command

Sends operational commands to this unit.

● Inquiry

Used for inquiring about the current state of this unit.

	Command Packet	Note
Inquiry	8X QQ RR ... FF	QQ ¹⁾ = Command/Inquiry, RR ²⁾ = category code

¹⁾ QQ = 01 (Command), 09 (Inquiry)

²⁾ RR = 00 (Interface), 04 (camera 1), 06 (Pan/Tilter)

X = 1 to 7: Address of this unit in the daisy chain

For actual values to be sent, see Command Lists or Inquiry Command Lists.

Responses for commands and inquiries

● Acknowledge message

A message returned by this unit when it receives a command. No Acknowledge message is returned for an inquiry, cancel, or device setting command.

● Completion message

A message returned by this unit when the execution of command or inquiry is completed. In the case of inquiry commands, reply data for the inquiry is contained after the 3rd byte of the packet. If the Acknowledge message is omitted, the socket number will contain 0.

	Reply Packet	Note
Acknowledge	X0 4Y FF	Y = socket number
Completion (Commands)	X0 5Y FF	Y = socket number
Completion (Inquiries)	X0 5Y ... FF	Y = socket number

X = 9 to F: Address of this unit specified when the command or inquiry is executed + 8.

● Error message

When a command could not be executed or failed, an error message is returned instead of an Acknowledge message. In some commands (such as zoom) in which the process is not completed immediately after the Acknowledge message, an error message may be returned after an Acknowledge message. When an inquiry command could not be executed or failed, an error message is returned instead of a completion message.

Error Packet	Description
X0 6Y 01 FF	Message length error
X0 60 02 FF	Syntax Error
X0 60 03 FF	Command buffer full
X0 6Y 04 FF	Command canceled
X0 6Y 05 FF	No socket (to be canceled)
X0 6Y 41 FF	Command not executable

X = 9 to F: Address of this unit specified when the command is executed + 8, Y = socket number

Socket number

This unit has two sets of sockets (buffers) for commands, so that up to two commands including the commands currently being executed can be received. When this unit receives commands, it notifies the sender which socket was used, using the socket number of the Acknowledge message. As each of the completion message and error message also has a socket number, you can identify which command has ended.

When sending the commands continuously, be sure to wait until an Acknowledge message or error message of the first command is returned, then send the next command. (Otherwise, it is impossible to identify to which command the socket number belongs.)

Even when two sockets are being used, the device setting commands and some inquiry messages can be executed. The Acknowledge message is not returned for these commands and inquiries, and only the completion message of socket number 0 is returned.

Command execution cancel

To cancel a command which has already been sent, send a Cancel command as the next command.

	Cancel Packet	Note
Cancel	8X 2Y FF	Y = socket number
X = 1 to 7: Address of this unit in the daisy chain, Y = socket number		

Error message "Command canceled" will be returned for this command, but this is not a fault. It indicates that the command has been canceled.

VISCA Device Setting Command

Before starting control of this unit, be sure to send the Address command and the IF_Clear command using the broadcast function.

For VISCA network administration

- **Address**
Sets an address of a peripheral device. Use when initializing the network, and receiving the following network change message.
- **Network Change**
Sent from the peripheral device to the controller when a device is removed from or added to the network. The address must be re-set when this message is received.

	Packet	Note
Address	88 30 01 FF	Always broadcasted.
Network Change	X0 38 FF	
X = 9 to F: SRG address + 8		

VISCA interface command

- **IF_Clear**
Clears the socket in the SRG.
When cleared, the operation currently being executed is not guaranteed.

	Command Packet	Reply Packet	Note
IF_Clear	8X 01 00 01 FF	Z0 50 FF	
IF_Clear (broadcast)	88 01 00 01 FF	88 01 00 01 FF	
X = 1 to 7: Address of this unit in the daisy chain (For inquiry packet)			
Z = 9 to F: Address of this unit that issued IF_Clear command +8 (For reply packet)			

VISCA interface and inquiry

● CAM_VersionInq

Returns information on the VISCA interface.

Inquiry	Inquiry Packet	Reply Packet	Description
CAM_VersionInq	8X 09 00 02 FF	Y0 50 GG GG HH HH JJ JJ KK FF	GGGG = Vender ID (0001: Sony) HHHH = Model ID (0516: SRG-300SE/301SE) JJJJ = ROM revision KK = Maximum socket # (02)

X = 1 to 7: Address of this unit in the daisy chain (For inquiry packet)

Y = 9 to F: Address of this unit that issued the inquiry +8 (For reply packet)

VISCA Command/Acknowledge Protocol

Command	Command Message	Reply Message	Comments
General Command	81 01 04 38 02 FF (Example)	90 41 FF (Acknowledge) +90 51 FF (Completion) 90 42 FF 90 52 FF	Returns Acknowledge when a command has been accepted, or Completion when a command has been executed.
	81 01 04 38 FF (Example)	90 60 02 FF (Syntax Error)	Accepted a command which is not supported or a command lacking parameters.
	81 01 04 38 02 FF (Example)	90 60 03 FF (Command Buffer Full)	Could not accept the command as there are two commands currently being executed.
	81 01 04 08 02 FF (Example)	90 61 41 FF (Command Not Executable) 90 62 41 FF	Could not execute the command in the current mode.
Inquiry Command	81 09 04 38 FF (Example)	90 50 02 FF (Completion)	Does not return Acknowledge.
	81 09 05 38 FF (Example)	90 60 02 FF (Syntax Error)	Accepted an incompatible command.
Command Cancel	81 22 FF (Example)	90 62 04 FF (Command Canceled)	Returned when the command of the socket specified is canceled. Completion for the command canceled is not returned.
		90 62 05 FF (No Socket)	Returned when the command of the specified socket has already been completed or when the socket number specified is wrong.
Address Set	88 30 01 FF	88 30 02 FF	The device address number plus 1 is returned.
IF_Clear (Broadcast)	88 01 00 01 FF	88 01 00 01 FF	The same command is returned.
IF Clear (for device address 1)	81 01 00 01 FF (Example)	90 50 FF (Completion)	Acknowledge is not returned for this command.

VISCA Camera-Issued Messages

Acknowledge/Completion Messages

Command	Command Message	Comments
Acknowledge	z0 4y FF (y: Socket No.)	Returned when the command is accepted.
Completion	z0 5y FF (y: Socket No.)	Returned when the command has been executed.

z = Address of device that issued the message + 8

Error Messages

Command	Command Message	Comments
Syntax Error	z0 60 02 FF	Returned when the format is different or when a command with illegal parameters is accepted.
Command Buffer Full	z0 60 03 FF	Could not accept a command that is received while two commands are currently being executed (two sockets have been used).
Command Canceled	z0 6y 04 FF (y: Socket No.)	Returned when a command which is being executed in a socket specified by the cancel command is canceled. The completion message for the command is not returned.
No Socket	z0 6y 05 FF (y: Socket No.)	Returned when no command is executed in a socket specified by the cancel command, or when an invalid socket number is specified.
Command Not Executable	z0 6y 41 FF (y: Socket No.)	Returned when a command cannot be executed due to current conditions. For example, when a command for controlling the manual focus is received during the auto focus mode.

z = Address of device that issued the error + 8

Network Change Message

Command	Command Message	Comments
Network Change	z0 38 FF	Issued when power is supplied to the camera.

SRG-300SE/SRG-301SE Commands

Execution Command List (1/4)

Command Set	Command	Command Packet	Comments
AddressSet	Broadcast	88 30 01 FF	Address setting
IF_Clear	Broadcast	88 01 00 01 FF	I/F Clear
CommandCancel	—	8x 2p FF	p: Socket No. (=1or2)
CAM_Zoom	Stop	8x 01 04 07 00 FF	Zoom Control
	Tele (Standard)	8x 01 04 07 02 FF	
	Wide (Standard)	8x 01 04 07 03 FF	
	Tele (Variable)	8x 01 04 07 2p FF	p=0 (Low) to 7 (High)
	Wide (Variable)	8x 01 04 07 3p FF	
	Direct	8x 01 04 47 0p 0q 0r 0s FF	pqrs: Zoom Position
CAM_DZoom	On	8x 01 04 06 02 FF	Digital zoom ON/OFF
	Off	8x 01 04 06 03 FF	
CAM_Focus	Stop	8x 01 04 08 00 FF	Focus Control
	Far (Standard)	8x 01 04 08 02 FF	
	Near (Standard)	8x 01 04 08 03 FF	
	Far (Variable)	8x 01 04 08 2p FF	p=0 (Low) to 7 (High)
	Near (Variable)	8x 01 04 08 3p FF	
	Direct	8x 01 04 48 0p 0q 0r 0s FF	pqrs: Focus Position
	Auto Focus	8x 01 04 38 02 FF	AF ON/OFF
	Manual Focus	8x 01 04 38 03 FF	
	Auto/Manual	8x 01 04 38 10 FF	
	One Push Trigger	8x 01 04 18 01 FF	One Push AF Trigger
	Infinity	8x 01 04 18 02 FF	Forced infinity
Near Limit	8x 01 04 28 0p 0q 0r 0s FF	pqrs: Focus Near Limit Position	
AF Sensitivity	Normal	8x 01 04 58 02 FF	AF Sensitivity High/Low
	Low	8x 01 04 58 03 FF	
CAM_AFMMode	Normal AF	8x 01 04 57 00 FF	AF Movement Mode
	Interval AF	8x 01 04 57 01 FF	
	Zoom Trigger AF	8x 01 04 57 02 FF	
	Active/Interval Time	8x 01 04 27 0p 0q 0r 0s FF	pq: Movement Time, rs: Interval
CAM_IRCorrection	Standard	8x 01 04 11 00 FF	FOCUS IR Correction setting
	IR Light	8x 01 04 11 01 FF	
CAM_ZoomFocus	Direct	8x 01 04 47 0p 0q 0r 0s 0t 0u 0v 0w FF	pqrs: Zoom Position tuvw: Focus Position
CAM_WB	Auto	8x 01 04 35 00 FF	Normal Auto
	Indoor	8x 01 04 35 01 FF	Indoor mode
	Outdoor	8x 01 04 35 02 FF	Out door mode
	One Push WB	8x 01 04 35 03 FF	One Push WB mode
	ATW	8x 01 04 35 04 FF	Auto Tracing White Balance
	Manual	8x 01 04 35 05 FF	Manual Control Mode
	One Push Trigger ¹⁾	8x 01 04 10 05 FF	One Push WB Trigger
CAM_RGain	Reset	8x 01 04 03 00 FF	Manual Control of R Gain
	Up	8x 01 04 03 02 FF	
	Down	8x 01 04 03 03 FF	
	Direct	8x 01 04 43 00 00 0p 0q FF	pq: R Gain
CAM_BGain	Reset	8x 01 04 04 00 FF	Manual Control of B Gain
	Up	8x 01 04 04 02 FF	
	Down	8x 01 04 04 03 FF	
	Direct	8x 01 04 44 00 00 0p 0q FF	pq: B Gain

Execution Command List (2/4)

Command Set	Command	Command Packet	Comments
CAM_AE	Full Auto	8x 01 04 39 00 FF	Automatic Exposure mode
	Manual	8x 01 04 39 03 FF	Manual Control mode
	Shutter Priority	8x 01 04 39 0A FF	Shutter priority Exposure mode
	Iris Priority	8x 01 04 39 0B FF	Iris priority Exposure mode
	Bright ²⁾	8x 01 04 39 0D FF	Bright Mode(Manual control)
CAM_SlowShutter	Auto	8x 01 04 5A 02 FF	Auto Slow Shutter ON/OFF
	Manual	8x 01 04 5A 03 FF	
CAM_Shutter	Reset	8x 01 04 0A 00 FF	Shutter Setting
	Up	8x 01 04 0A 02 FF	
	Down	8x 01 04 0A 03 FF	
	Direct	8x 01 04 4A 00 00 0p 0q FF	pq: Shutter Position
CAM_Iris	Reset	8x 01 04 0B 00 FF	Iris Setting
	Up	8x 01 04 0B 02 FF	
	Down	8x 01 04 0B 03 FF	
	Direct	8x 01 04 4B 00 00 0p 0q FF	pq: Iris Position
CAM_Gain	Reset	8x 01 04 0C 00 FF	Gain Setting
	Up	8x 01 04 0C 02 FF	
	Down	8x 01 04 0C 03 FF	
	Direct	8x 01 04 4C 00 00 0p 0q FF	pq: Gain Position
	AE Gain Limit	8x 01 04 2C 0p FF	p: Gain Position (4 to F)
CAM_Bright	Up	8x 01 04 0D 02 FF	—
	Down	8x 01 04 0D 03 FF	
	Direct	8x 01 04 4D 00 00 0p 0q FF	pq: Bright Position
CAM_ExpComp	On	8x 01 04 3E 02 FF	Exposure Compensation ON/OFF
	Off	8x 01 04 3E 03 FF	
	Reset	8x 01 04 0E 00 FF	Exposure Comp Amount Setting
	Up	8x 01 04 0E 02 FF	
	Down	8x 01 04 0E 03 FF	
	Direct	8x 01 04 4E 00 00 0p 0q FF	pq: ExpComp Position
CAM_BackLight	On	8x 01 04 33 02 FF	Back Light Comp ON/OFF
	Off	8x 01 04 33 03 FF	
CAM_WD	Off	8x 01 7E 04 00 00 FF	Wide Dynamic Range Mode
	Low	8x 01 7E 04 00 01 FF	
	Mid	8x 01 7E 04 00 02 FF	
	High	8x 01 7E 04 00 03 FF	
CAM_Defog	On	8x 01 04 37 02 00 FF	Defog Mode
	Off	8x 01 04 37 03 00 FF	
CAM_Aperture	Reset	8x 01 04 02 00 FF	Aperture Setting
	Up	8x 01 04 02 02 FF	
	Down	8x 01 04 02 03 FF	
	Direct	8x 01 04 42 00 00 0p 0q FF	pq: Aperture Gain
CAM_HR	On	8x 01 04 52 02 FF	High-Resolution Mode ON/OFF
	Off	8x 01 04 52 03 FF	
CAM_NR	—	8x 01 04 53 0p FF	p: NR Setting (0:OFF, Level1 to 5)
CAM_Gamma	—	8x 01 04 5B 0p FF	p: Gamma setting 0: Standard 1: OFF
CAM_HighSensitivity	On	8x 01 04 5E 02 FF	High Sensitivity mode ON/OFF
	Off	8x 01 04 5E 03 FF	
CAM_PictureEffect	Off	8x 01 04 63 00 FF	Picture Effect Setting
	Neg.Art	8x 01 04 63 02 FF	
	B&W	8x 01 04 63 04 FF	

Execution Command List (3/4)

Command Set	Command	Command Packet	Comments
CAM_ICR	On	8x 01 04 01 02 FF	Infrared Mode ON/OFF
	Off	8x 01 04 01 03 FF	
CAM_AutoICR	On	8x 01 04 51 02 FF	Auto Infrared mode ON/OFF
	Off	8x 01 04 51 03 FF	
	Threshold	8x 01 04 21 00 00 0p 0q FF	
CAM_Stabilizer	On	8x 01 04 34 02 FF	Stabilizer ON/OFF
	Off	8x 01 04 34 03 FF	
CAM_Memory	Reset	8x 01 04 3F 00 0p FF	p: Memory number (=0 to F)
	Set	8x 01 04 3F 01 0p FF	
	Recall	8x 01 04 3F 02 0p FF	
CAM_IDWrite	—	8x 01 04 22 0p 0q 0r 0s FF	pqrs: Camera ID (=0000 to FFFF)
CAM_ChromaSuppress	—	8x 01 04 5F pp FF	pp: Chroma Suppress setting level 00: OFF 1 to 3: ON (3 levels). Effect increases as the level number increases.
CAM_ColorGain	Direct	8x 01 04 49 00 00 0p 0q FF	p: Color specification q: Gain setting level The range of p is from 0 to 6. 0 : master, 1 : magenta, 2 : red, 3 : yellow, 4 : green, 5 : cyan, 6 : blue The range of q is from 0 to E. The initial value is 4. Gain Up with 5 or more, Gain Down with 3 or less.
CAM_ColorHue	Direct	8x 01 04 4F 00 00 0p 0q FF	p: Color specification q: Phase setting level The range of p is from 0 to 6. 0 : master, 1 : magenta, 2 : red, 3 : yellow, 4 : green, 5 : cyan, 6 : blue The q is setting level of phase and the range is from 0 to E. The initial value is 7. Phase (+ direction) with 8 or more, Phase (- direction) with 6 or less.
SYS_Menu	Off	8x 01 06 06 03 FF	Erasing menu display
Information Display	On	8x 01 7E 01 18 02 FF	Operation status screen display ON/OFF of One Push Trigger for CAM_Memor and CAM_WB
	Off	8x 01 7E 01 18 03 FF	
Pan-tiltDrive	Up ³⁾	8x 01 06 01 VV WW 03 01 FF	VV: Pan speed setting 0x01 (low speed) to 0x18 (high speed) WW: Tilt speed setting 0x01 (low speed) to 0x17 (high speed) YYYY: Pan Position DE00 to 2200 (CENTER 0000) ZZZZ: Tilt Position FC00 to 1200 (Image Flip: OFF) (CENTER 0000) Tilt Position EE00 to 0400 (Image Flip: ON) (CENTER 0000)
	Down ³⁾	8x 01 06 01 VV WW 03 02 FF	
	Left ³⁾	8x 01 06 01 VV WW 01 03 FF	
	Right ³⁾	8x 01 06 01 VV WW 02 03 FF	
	UpLeft ³⁾	8x 01 06 01 VV WW 01 01 FF	
	UpRight ³⁾	8x 01 06 01 VV WW 02 01 FF	
	DownLeft ³⁾	8x 01 06 01 VV WW 01 02 FF	
	DownRight ³⁾	8x 01 06 01 VV WW 02 02 FF	
	Stop ³⁾	8x 01 06 01 VV WW 03 03 FF	
	AbsolutePosition	8x 01 06 02 VV WW 0Y 0Y 0Y 0Y 0Z 0Z 0Z 0Z FF	
	RelativePosition	8x 01 06 03 VV WW 0Y 0Y 0Y 0Y 0Z 0Z 0Z 0Z FF	
	Home	8x 01 06 04 FF	
	Reset	8x 01 06 05 FF	

Execution Command List (4/4)

Command Set	Command	Command Packet	Comments
Pan-tiltLimitSet	LimitSet	8x 01 06 07 00 0W 0Y 0Y 0Y 0Y 0Z 0Z 0Z 0Z FF	W: 1 UpRight YYYY: Pan Limit Position DE01 to 2200
	LimitClear	8x 01 06 07 01 0W 07 0F 0F 0F 07 0F 0F 0F FF	ZZZZ: Tilt Limit Position FC01 to 1200 (Image Flip: OFF) Tilt Limit Position EE01 to 0400 (Image Flip: ON) 0 DownLeft YYYY: Pan Limit Position DE00 to 21FF ZZZZ: Tilt Limit Position FC00 to 11FF (Image Flip: OFF) Tilt Limit Position EE00 to 03FF (Image Flip: ON)
Pan-tiltSet SlowPanTilt	On	8x 01 06 44 02 FF	PAN/TILT SLOW MODE ON/OFF
	Off	8x 01 06 44 03 FF	

- 1) After the ACK for One Push WB Trigger is issued, "Not Executable" is returned to all commands until the operation is completed.
- 2) Bright is set only in the mode of Full Auto or Shutter Priority.
- 3) Does not operate when the menu is displayed.

Inquiry Command List (1/2)

Inquiry Command	Command Packet	Inquiry Packet	Comments
CAM_PowerInq	8x 09 04 00 FF	y0 50 02 FF	On
CAM_ZoomPosInq	8x 09 04 47 FF	y0 50 0p 0q 0r 0s FF	pqrs: Zoom Position
CAM_DZoomModeInq	8x 09 04 06 FF	y0 50 02 FF	D-Zoom On
		y0 50 03 FF	D-Zoom Off
CAM_FocusModeInq	8x 09 04 38 FF	y0 50 02 FF	Auto Focus
		y0 50 03 FF	Manual Focus
CAM_FocusPosInq	8x 09 04 48 FF	y0 50 0p 0q 0r 0s FF	pqrs: Focus Position
CAM_FocusNearLimitInq	8x 09 04 28 FF	y0 50 0p 0q 0r 0s FF	pqrs: Focus Near Limit Position
CAM_AFSensitivityInq	8x 09 04 58 FF	y0 50 02 FF	AF Sensitivity Normal
		y0 50 03 FF	AF Sensitivity Low
CAM_AFModeInq	8x 09 04 57 FF	y0 50 00 FF	Normal AF
		y0 50 01 FF	Interval AF
		y0 50 02 FF	Zoom Trigger AF
CAM_AFTimeSettingInq	8x 09 04 27 FF	y0 50 0p 0q 0r 0s FF	pq: Movement Time, rs: Interval
CAM_IRCorrectionInq	8x 09 04 11 FF	y0 50 00 FF	Standard
		y0 50 01 FF	IR Light
CAM_WBModeInq	8x 09 04 35 FF	y0 50 00 FF	Auto
		y0 50 01 FF	In Door
		y0 50 02 FF	Out Door
		y0 50 03 FF	One Push WB
		y0 50 04 FF	ATW
		y0 50 05 FF	Manual
CAM_RGainInq	8x 09 04 43 FF	y0 50 00 00 0p 0q FF	pq: R Gain
CAM_BGainInq	8x 09 04 44 FF	y0 50 00 00 0p 0q FF	pq: B Gain
CAM_AEModeInq	8x 09 04 39 FF	y0 50 00 FF	Full Auto
		y0 50 03 FF	Manual
		y0 50 0A FF	Shutter Priority
		y0 50 0B FF	Iris Priority
		y0 50 0D FF	Bright
CAM_SlowShutterModeInq	8x 09 04 5A FF	y0 50 02 FF	Auto
		y0 50 03 FF	Manual
CAM_ShutterPosInq	8x 09 04 4A FF	y0 50 00 00 0p 0q FF	pq: Shutter Position
CAM_IrisPosInq	8x 09 04 4B FF	y0 50 00 00 0p 0q FF	pq: Iris Position
CAM_GainPosInq	8x 09 04 4C FF	y0 50 00 00 0p 0q FF	pq: Gain Position
CAM_GainLimitInq	8x 09 04 2C FF	y0 50 0q FF	p: Gain Limit
CAM_BrightPosInq	8x 09 04 4D FF	y0 50 00 00 0p 0q FF	pq: Bright Position
CAM_ExpCompModeInq	8x 09 04 3E FF	y0 50 02 FF	On
		y0 50 03 FF	Off
CAM_ExpCompPosInq	8x 09 04 4E FF	y0 50 00 00 0p 0q FF	pq: ExpComp Position
CAM_BackLightModeInq	8x 09 04 33 FF	y0 50 02 FF	On
		y0 50 03 FF	Off
CAM_WDModeInq	8x 09 7E 04 00 FF	y0 50 00 FF	Wide Dynamic Range Mode 00 FF : OFF 01 FF : LOW 02 FF : MID 03 FF : HIGH
		y0 50 01 FF	
		y0 50 02 FF	
		y0 50 03 FF	
CAM_DefogInq	8x 09 04 37 FF	y0 50 02 00 FF	Defog Mode ON
		y0 50 03 00 FF	Defog Mode OFF
CAM_ApertureInq	8x 09 04 42 FF	y0 50 00 00 0p 0q FF	pq: Aperture Gain
CAM_HRModeInq	8x 09 04 52 FF	y0 50 02 FF	On
		y0 50 03 FF	Off
CAM_NRInq	8x 09 04 53 FF	y0 50 0p FF	p: NR Level
CAM_GammaInq	8x 09 04 5B FF	y0 50 0p FF	p: Gamma

Inquiry Command List (2/2)

Inquiry Command	Command Packet	Inquiry Packet	Comments
CAM_HighSensitivityInq	8x 09 04 5E FF	y0 50 02 FF	On
		y0 50 03 FF	Off
CAM_PictureEffectModeInq	8x 09 04 63 FF	y0 50 00 FF	Off
		y0 50 02 FF	Neg.Art
		y0 50 04 FF	B&W
CAM_ICRModeInq	8x 09 04 01 FF	y0 50 02 FF	On
		y0 50 03 FF	Off
CAM_AutoICRModeInq	8x 09 04 51 FF	y0 50 02 FF	On
		y0 50 03 FF	Off
CAM_AutoICRThresholdInq	8x 09 04 21 FF	y0 50 00 00 0p 0q FF	pq: ICR ON→OFF Threshold level
CAM_Stabilizer ModeInq	8x 09 04 34 FF	y0 50 02 FF	On
		y0 50 03 FF	Off
CAM_IDInq	8x 09 04 22 FF	y0 50 0p 0q 0r 0s FF	pqrs: Camera ID
CAM_VersionInq	8x 09 00 02 FF	y0 50 00 01 mn pq rs tu vw FF	mnpq: Model Code (0513) rstu: ROM version vw: Socket Number (=02) see page 20.
CAM_Stabilizer ModeInq	8x 09 04 34 FF	y0 50 02 FF	On
		y0 50 03 FF	Off
CAM_ChromaSuppressInq	8x 09 04 5F FF	y0 50 pp FF	pp: Chroma Suppress setting level
CAM_ColorGainInq	8x 09 04 49 FF	y0 50 00 00 00 0p FF	p: ColorGain setting 0h (60%) to Eh (200%)
CAM_ColorHueInq	8x 09 04 4F FF	y0 50 00 00 00 0p FF	p: ColorHue setting 0h (-14 degrees) to Eh (+14 degrees)
SYS_MenuModeInq	8x 09 06 06 FF	y0 50 02 FF	ON
		y0 50 03 FF	OFF
Information Display	8x 09 7E 01 18 FF	y0 50 02 FF	ON
		y0 50 03 FF	OFF
Pan-tiltMaxSpeedInq	8x 09 06 11 FF	y0 50 ww zz FF	ww = Pan Max Speed zz = Tilt Max Speed
Pan-tiltPosInq	8x 09 06 12 FF	y0 50 0w 0w 0w 0w 0z 0z 0z 0z FF	wwww = Pan Position zzzz = Tilt Position
Pan-tiltModeInq	8x 09 06 10 FF	y0 50 pq rs FF	pqrs: Pan-tilt Status
SlowPanTiltInq	8x 09 06 44 FF	y0 50 02 FF	ON
		y0 50 03 FF	OFF

Block Inquiry Command List

Lens Control System Inquiry CommandsCommand Packet 8x 09 7E 7E 00 FF

Inquiry Packet

Byte	Bit	Comments	Byte	Bit	Comments	Byte	Bit	Comments	
0	7	Destination Address	6	7	0	12	7	0	
	6			0	6		0		
	5			0	5		0		
	4			0	4		0		
	3	Source Address		3	Focus Near Limit (H)		3	0	
	2			2			0		
	1			1			0		
	0			0			0		
1	7	0 Completion Message (50h)	7	7	0	13	7	0	
	6	1		6	0		6	0	
	5	0		5	0		5	0	
	4	1		4	0		4	AF Mode (0:Normal, 1:Interval, 2:Zoom Trigger)	
	3	0		3	Focus Near Limit (L)		3		AF Sensitivity (1:Normal, 0:Low)
	2	0		2			2	Digital Zoom (1:On, 0:Off)	
	1	0		1			1	1	Focus Mode (1:Auto, 0:Manual)
	0	0		0			0	0	
2	7	0	8	7	0	14	7	0	
	6	0		6	0		6	0	
	5	0		5	0		5	0	
	4	0		4	0		4	0	
	3	Zoom Position (HH)		3	Focus Position (HH)		3	Low Contrast Detection (1:Yes, 0: No)	
	2			2			Camera Memory Recall (1: Executing, 0: Stopped)		
	1			1				1	Focus Command 1: Executing 0: Stopped
	0			0			0	0	Zoom Command 1: Executing 0: Stopped
3	7	0	9	7	0	15	7	1 Terminator (FFh)	
	6	0		6	0		6	1	
	5	0		5	0		5	1	
	4	0		4	0		4	1	
	3	Zoom Position (HL)		3	Focus Position (HL)		3	1	
	2			2			1		
	1			1			1		
	0			0			0	1	
4	7	0	10	7	0		7	0	
	6	0		6	0		6	0	
	5	0		5	0		5	0	
	4	0		4	0		4	0	
	3	Zoom Position (LH)		3	Focus Position (LH)		3	0	
	2			2			0		
	1			1			0		
	0			0			0		
5	7	0	11	7	0		7	0	
	6	0		6	0		6	0	
	5	0		5	0		5	0	
	4	0		4	0		4	0	
	3	Zoom Position (LL)		3	Focus Position (LL)		3	0	
	2			2			0		
	1			1			0		
	0			0			0		

Camera Control System Inquiry CommandsCommand Packet 8x 09 7E 7E 01 FF

Inquiry Packet

Byte	Bit	Comments
0	7	Destination Address
	6	
	5	
	4	
	3	Source Address
	2	
	1	
	0	
1	7	0 Completion Message (50h)
	6	1
	5	0
	4	1
	3	0
	2	0
	1	0
	0	0
2	7	0
	6	0
	5	0
	4	0
	3	R Gain (H)
	2	
	1	
	0	
3	7	0
	6	0
	5	0
	4	0
	3	R Gain (L)
	2	
	1	
	0	
4	7	0
	6	0
	5	0
	4	0
	3	B Gain (H)
	2	
	1	
	0	
5	7	0
	6	0
	5	0
	4	0
	3	B Gain (L)
	2	
	1	
	0	

Byte	Bit	Comments
6	7	0
	6	0
	5	0
	4	0
	3	WB Mode
	2	
	1	
	0	
7	7	0
	6	0
	5	0
	4	0
	3	Aperture Gain
	2	
	1	
	0	
8	7	0
	6	0
	5	0
	4	Exposure Mode
	3	
	2	
	1	
	9	7
6		0
5		HighResolution (1:On, 0:Off)
4		Wide D (1: Other than Off, 0: Off)
3		0
2		Back Light (1:On, 0:Off)
1		Exposure Comp. (1:On, 0:Off)
0		Slow Shutter (1:Auto, 0:Manual)
10	7	0
	6	0
	5	0
	4	Shutter Position
	3	
	2	
	1	
	0	

Byte	Bit	Comments
11	7	0
	6	0
	5	0
	4	Iris Position
	3	
	2	
	1	
	12	7
6		0
5		0
4		0
3		Gain Position
2		
1		
0		
13	7	0
	6	0
	5	0
	4	Bright Position
	3	
	2	
	1	
	14	7
6		0
5		0
4		0
3		Exposure Comp. Position
2		
1		
0		
15	7	1 Terminator (FFh)
	6	1
	5	1
	4	1
	3	1
	2	1
	1	1
	0	1

Other Inquiry CommandsCommand Packet 8x 09 7E 7E 02 FF

Inquiry Packet

Byte	Bit	Comments
0	7	Destination Address
	6	
	5	
	4	
	3	Source Address
	2	
	1	
	0	
1	7	0 Completion Message (50h)
	6	1
	5	0
	4	1
	3	0
	2	0
	1	0
	0	0
2	7	0
	6	0
	5	0
	4	0
	3	0
	2	Auto ICR (1:On, 0:Off)
	1	0
	0	Power (1:On, 0:Off)
3	7	0
	6	Stabilizer (1:On, 0:Off)
	5	Reserved
	4	ICR (1:On, 0:Off)
	3	0
	2	0
	1	0
	0	0
4	7	0
	6	0
	5	0
	4	Reserved
	3	0
	2	0
	1	0
	0	0
5	7	0
	6	0
	5	0
	4	0
	3	Picture Effect Mode
	2	
	1	
	0	

Byte	Bit	Comments
6	7	0
	6	0
	5	0
	4	0
	3	0
	2	0
	1	0
	0	0
7	7	0
	6	0
	5	0
	4	0
	3	0
	2	0
	1	0
	0	0
8	7	0
	6	0
	5	0
	4	0
	3	Camera ID (HH)
	2	
	1	
	0	
9	7	0
	6	0
	5	0
	4	0
	3	Camera ID (HL)
	2	
	1	
	0	
10	7	0
	6	0
	5	0
	4	0
	3	Camera ID (LH)
	2	
	1	
	0	
11	7	0
	6	0
	5	0
	4	0
	3	Camera ID (LL)
	2	
	1	
	0	

Byte	Bit	Comments
12	7	0
	6	0
	5	0
	4	1
	3	0
	2	1
	1	1
	0	System (1:1/50, 1/25, 0:1/59.94, 1/29.97)
13	7	0
	6	0
	5	0
	4	0
	3	0
	2	0
	1	0
	0	0
14	7	0
	6	0
	5	0
	4	0
	3	0
	2	0
	1	0
	0	0
15	7	1 Terminator (FFh)
	6	1
	5	1
	4	1
	3	1
	2	1
	1	1
	0	1

Enlargement Function1 Query CommandCommand Packet 8x 09 7E 7E 03 FF

Inquiry Packet

Byte	Bit	Comments	Byte	Bit	Comments	Byte	Bit	Comments			
0	7	Destination Address	6	7	0	12	7	0			
	6			0	6		0				
	5			0	5		0				
	4			0	4		0				
	3	Source Address		3	AF Interval Time (H)		3	0			
	2			2			0				
	1			1			0				
	0			0			1				
1	7	0 Completion Message (50h)	7	7		0	13	7	0		
	6	1		6		0		6	Gamma		
	5	0		5		0		5		0	
	4	1		4		0		4		0	
	3	0		3	AF Interval Time (L)	3		High Sensitivity mode (1: ON, 0: OFF)			
	2	0		2		0			2	NR Level	
	1	0		1		0			1		0
	0	0		0		0			0		0
2	7	0	8	7	0	14	7		0		
	6	0		6	0		6		Chroma Suppress		
	5	0		5	0		5			0	
	4	0		4	0		4			0	
	3	Digital Zoom Position (H)		3	1		3	Gain Limit			
	2			0	2		0		2	0	
	1			0	1		0		1	0	
	0			0	0		0		0	0	
3	7	0	9	7	0	15	7		1 Terminator (FFh)		
	6	0		6	0		6		1		
	5	0		5	0		5		1		
	4	0		4	0		4		1		
	3	Digital Zoom Position (L)		3	1		3	1			
	2			0	2		0	2	1		
	1			0	1		0	1	1		
	0			0	0		0	0	1		
4	7	0	10	7	0	11	7	0			
	6	0		6	0		6	Color Gain (Master)			
	5	0		5	0		5		0		
	4	0		4	0		4		0		
	3	AF Activation Time (H)		3	0		3		0		
	2			0	2		0	2	1		
	1			0	1		0	1	1		
	0			0	0		0	0	1		
5	7	0	11	7	0	11	7	0			
	6	0		6	Color Gain (Master)						
	5	0		5			0	5	0		
	4	0		4			0	4	0		
	3	AF Activation Time (L)		3			1	3	1		
	2			1	2		1	2	1		
	1			1	1		1	1	1		
	0			1	0		1	0	1		

Enlargement Function2 Query CommandCommand Packet 8x 09 7E 7E 04 FF

Inquiry Packet

Byte	Bit	Comments	Byte	Bit	Comments	Byte	Bit	Comments
0	7	Destination Address	6	7	0	12	7	0
	6			0	6		0	
	5			0	5		0	
	4			0	4		0	
	3	Source Address		3	0		3	0
	2			0	2		0	
	1			Reserved	1		0	
	0			Reserved	0		0	
1	7	0 Completion Message (50h)	7	7	0	13	7	0
	6	1		6	0		6	0
	5	0		5	0		5	0
	4	1		4	0		4	0
	3	0		3	0		3	0
	2	0		2	0		2	0
	1	0		1	0		1	0
	0	0		0	defog mode 0:Off 1:On		0	0
2	7	0	8	7	0	14	7	0
	6	0		6	0		6	0
	5	0		5	0		5	0
	4	0		4	0		4	0
	3	0		3	0		3	0
	2	0		2	0		2	0
	1	Reserved		1	0		1	0
	0	Reserved		0	0		0	0
3	7	0	9	7	0	15	7	1 Terminator (FFh)
	6	0		6	0		6	1
	5	0		5	0		5	1
	4	0		4	0		4	1
	3	0		3	0		3	1
	2	0		2	0		2	1
	1	0		1	0		1	1
	0	0		0	0		0	1
4	7	0	10	7	0	11	7	0
	6	0		6	0		6	0
	5	0		5	0		5	0
	4	0		4	0		4	0
	3	0		3	0		3	0
	2	Reserved		2	0		2	0
	1	Reserved		1	0		1	0
	0	Reserved		0	0		0	0
5	7	0	11	7	0	11	7	0
	6	0		6	0		6	0
	5	0		5	0		5	0
	4	0		4	0		4	0
	3	0		3	0		3	0
	2	0		2	0		2	0
	1	Reserved		1	0		1	0
	0	Reserved		0	0		0	0

Enlargement Function3 Query CommandCommand Packet 8x 09 7E 7E 05 FF

Inquiry Packet

Byte	Bit	Comments	Byte	Bit	Comments	Byte	Bit	Comments				
0	7	Destination Address	6	7	0	12	7	0				
	6			Source Address	Reserved		Reserved					
	5							0	Reserved			
	4									0	Reserved	
	3	0										Reserved
	2			0	Reserved							
	1						0	Reserved				
	0								0	Reserved		
7	0 Completion Message (50h)	7	7			0					13	7
6	1		Reserved	Reserved								
5	0				Reserved							
4	1					Reserved						
3	0						Reserved					
2	0		Reserved									
1	0			Reserved								
0	0				Reserved							
2	7	0				8	7	0	14	7	0	
	6	0	Reserved				Reserved					
	5	0		Reserved								
	4	0			Reserved							
	3	Color Hue (Master)						Reserved				
2	Reserved											
1			Reserved									
0				Reserved								
3		7			0	9	7	0	15	7	1 Terminator (FFh)	
	6	Reserved			Reserved		Reserved					
	5		Reserved					Reserved				
	4			Reserved						Reserved		
	3										Reserved	Reserved
	2	Reserved			Reserved							
	1		Reserved				Reserved					
	0			Reserved				Reserved				
4	7					0			10	7	0	15
	6	Reserved			Reserved	Reserved						
	5		Reserved				Reserved					
	4			Reserved				Reserved				
	3									Reserved	Reserved	
2	Reserved	Reserved										
1			Reserved		Reserved							
0				Reserved		Reserved						
5							7	0	11	7	0	15
	6	Reserved					Reserved	Reserved				
	5		Reserved		Reserved							
	4			Reserved		Reserved						
	3									Reserved	Reserved	
	2	Reserved					Reserved					
	1		Reserved		Reserved							
	0			Reserved		Reserved						

VISCA Command Setting Values

Exposure control (1/2)

		60p/30p	50p/25p
Shutter Speed	15	1/10000	1/10000
	14	1/6000	1/6000
	13	1/4000	1/3500
	12	1/3000	1/2500
	11	1/2000	1/1750
	10	1/1500	1/1250
	0F	1/1000	1/1000
	0E	1/725	1/600
	0D	1/500	1/425
	0C	1/350	1/300
	0B	1/250	1/215
	0A	1/180	1/150
	09	1/125	1/120
	08	1/100	1/100
	07	1/90	1/75
	06	1/60	1/50
	05	1/30	1/25
	04	1/15	1/12
	03	1/8	1/6
	02	1/4	1/3
01	1/2	1/2	
00	1/1	1/1	

Iris	11	F1.6
	10	F2
	0F	F2.4
	0E	F2.8
	0D	F3.4
	0C	F4
	0B	F4.8
	0A	F5.6
	09	F6.8
	08	F8
	07	F9.6
	06	F11
	05	F14
	00	CLOSE

Gain	0F	+43dB
	0E	+39dB
	0D	+36dB
	0C	+33dB
	0B	+30dB
	0A	+27dB
	09	+24dB
	08	+21dB
	07	+18dB
	06	+15dB
	05	+12dB
	04	+9dB
	03	+6dB
	02	+3dB
	01	0dB

Gain Limit	0F	+43dB
	0E	+39dB
	0D	+36dB
	0C	+33dB
	0B	+30dB
	0A	+27dB
	09	+24dB
	08	+21dB
	07	+18dB
	04	+9dB

Exposure control (2/2)

		IRIS	GAIN
Bright	1F	F1.6	+43dB
	1E	F1.6	+39dB
	1D	F1.6	+36dB
	1C	F1.6	+33dB
	1B	F1.6	+30dB
	1A	F1.6	+27dB
	19	F1.6	+24dB
	18	F1.6	+21dB
	17	F1.6	+18dB
	16	F1.6	+15dB
	15	F1.6	+12dB
	14	F1.6	+9dB
	13	F1.6	+6dB
	12	F1.6	+3dB
	11	F1.6	0dB
	10	F2	0dB
	0F	F2.4	0dB
	0E	F2.8	0dB
	0D	F3.4	0dB
	0C	F4	0dB
	0B	F4.8	0dB
	0A	F5.6	0dB
	09	F6.8	0dB
	08	F8	0dB
	07	F9.6	0dB
	06	F11	0dB
05	F14	0dB	
00	CLOSE	0	

		Display	Compensation Amount
Exposure Comp.	0E	+7	+10.5dB
	0D	+6	+9dB
	0C	+5	+7.5dB
	0B	+4	+6dB
	0A	+3	+4.5dB
	09	+2	+3dB
	08	+1	+1.5dB
	07	0	0dB
	06	-1	-1.5dB
	05	-2	-3dB
	04	-3	-4.5dB
	03	-4	-6dB
	02	-5	-7.5dB
	01	-6	-9dB
	00	-7	-10.5dB

Optical Zoom Ratio and Zoom Position (for reference)

Zoom Position: 0000 (Wide end) to 4000 (Tele end)

Optical Zoom Ratio	Optical Zoom Position Data
×1	0000
×2	16A1
×3	2063
×4	2628
×5	2A1D
×6	2D13
×7	2F6D
×8	3161
×9	330D
×10	3486
×11	35D7
×12	3709
×13	3820
×14	3920
×15	3A0A
×16	3ADD
×17	3B9C
×18	3C46
×19	3CDC
×20	3D60
×21	3DD4
×22	3E39
×23	3E90
×24	3EDC
×25	3F1E
×26	3F57
×27	3F8A
×28	3FB6
×29	3FDC
×30	4000

Digital Zoom

Digital Zoom Ratio	Digital Zoom Position Data
×1	4000
×2	6000
×3	6A80
×4	7000
×5	7300
×6	7540
×7	76C0
×8	7800
×9	78C0
×10	7980
×11	7A00
×12	7AC0

Focus NEAR limit and focus distance

Focus position: 1000 (Far end) to X000 (Near end)

NEAR Limit	Focus Distance
1000	Over Inf
2000	20m
3000	10m
4000	6m
5000	4.2m
6000	3.1m
7000	2.5m
8000	2m
9000	1.65m
A000	1.4m
B000	1.2m
C000	80cm
D000	30cm
E000	11cm
F000	1cm

Lens control

Zoom Position	0000	to	4000	to	7AC0
	Wide end		Optical Tele end		Digital Tele end
Focus Position	1000	to	F000		
	Far end		Near end		
Focus Near Limit	1000: Over Inf				
	2000: 20 m				
	3000: 10 m				
	4000: 6 m				
	5000: 4.2 m				
	6000: 3.1 m				
	7000: 2.5 m				
	8000: 2.0 m				
	9000: 1.65 m				
	A000: 1.4 m				
	B000: 1.2 m				
	C000: 0.8 m				
	D000: 30 cm				
	(initial setting)				
	E000: 11 cm				
	F000: 1 cm				

As the distance on the left will differ due to temperature characteristics, etc., use as approximate values.
*The lower 1 byte is fixed at 00.

Others

AF Active Time ¹⁾	00	to	FF
AF Interval Time ¹⁾	00	to	FF
R Gain	00	to	FF
B Gain	00	to	FF
Aperture Level	00	to	0F
AE Response	01	to	30
AutoICR ON →	00	to	1C
OFF Threshold Level			
Chroma Suppress setting level	00	to	03
Color Gain setting level	00	to	0E
Color Hue setting level	00	to	0E

¹⁾ Unit: One second

Pan/Tilt Speed (Pan/Tilt Slow Mode= Off)

Parameter	Speed (deg/sec)	
	Pan	Tilt
01h	1.1	1.1
02h	1.3	1.3
03h	1.6	1.6
04h	2.2	2.2
05h	2.9	2.9
06h	6.7	6.7
07h	11	11
08h	23	16
09h	24	26
0Ah	27	29
0Bh	41	31
0Ch	43	34
0Dh	47	50
0Eh	49	52
0Fh	54	54
10h	57	57
11h	62	62
12h	64	64
13h	69	69
14h	72	72
15h	80	80
16h	84	84
17h	91	91
18h ¹⁾	101	—

¹⁾ The maximum speed setting value of Pan is 18h and that of Tilt is 17h. Although you can set the value up to 7Fh, the speed is kept at the maximum speed.

Pan/Tilt Speed (Pan/Tilt Slow Mode= On)

Parameter	Speed (deg/sec) Pan/Tilt
01h	0.50
02h	0.70
03h	0.90
04h	1.10
05h	1.30
06h	1.50
07h	1.90
08h	2.30
09h	2.70
0Ah	3.10
0Bh	3.50
0Ch	4.10
0Dh	4.70
0Eh	5.30
0Fh	5.90
10h	6.50
11h	7.30
12h	8.10
13h	8.90
14h	9.50
15h	10.80
16h	13.20
17h	26.50
18h	60.00
19h	0.10
1Ah	0.20
1Bh	0.30
1Ch	0.40
1Dh	0.50
1Eh	0.60
1Fh	0.70
20h	0.80
21h	0.90
22h	1.00
23h	1.10
24h	1.20
25h	1.30
26h	1.40
27h	1.50
28h	1.60
29h	1.70
2Ah	1.80
2Bh	1.90
2Ch	2.00
2Dh	2.10
2Eh	2.20
2Fh	2.30

Parameter	Speed (deg/sec) Pan/Tilt
30h	2.40
31h	2.50
32h	2.60
33h	2.70
34h	2.80
35h	2.89
36h	3.00
37h	3.10
38h	3.20
39h	3.30
3Ah	3.40
3Bh	3.49
3Ch	3.61
3Dh	3.71
3Eh	3.79
3Fh	3.90
40h	4.00
41h	4.10
42h	4.20
43h	4.31
44h	4.40
45h	4.49
46h	4.61
47h	4.71
48h	4.82
49h	4.89
4Ah	5.00
4Bh	5.12
4Ch	5.20
4Dh	5.32
4Eh	5.41
4Fh	5.50
50h	5.59
51h	5.69
52h	5.79
53h	5.89
54h	6.00
55h	6.11
56h	6.22
57h	6.28
58h	6.41
59h	6.47
5Ah	6.60
5Bh	6.67
5Ch	6.80
5Dh	6.87
5Eh	7.02

Parameter	Speed (deg/sec) Pan/Tilt
5Fh	7.10
60h	7.25
61h	7.33
62h	7.41
63h	7.50
64h	7.58
65h	7.76
66h	7.86
67h	7.95
68h	8.05
69h	8.15
6Ah	8.25
6Bh	8.35
6Ch	8.46
6Dh	8.57
6Eh	8.68
6Fh	8.80
70h	8.92
71h	9.04
72h	9.16
73h	9.29
74h	9.43
75h	9.56
76h	9.70
77h	9.85
78h	10.00
79h	10.15
7Ah	10.31
7Bh	10.47
7Ch	10.64
7Dh	10.82
7Eh	11.00
7Fh	11.18

Pan/Tilt Status Code List

P	Q	R	S	
----	----	0---	---1	A Pan movement all the way to the left
----	----	0---	--1-	A Pan movement all the way to the right
----	----	0---	-1--	A Tilt movement all the way up
----	----	0---	1---	A Tilt movement all the way down
----	----	--00	----	Pan movement is correct
----	----	--01	----	Abnormal pan position detected
----	--00	0---	----	The Tilt movement is correct
----	--01	0---	----	Abnormal tilt position detected
----	00--	0---	----	No move request received
----	01--	0---	----	In the midst of a Pan/Tilt
----	10--	0---	----	Pan/Tilt completed
----	11--	0---	----	Pan/Tilt failed
--00	----	0---	----	Not initialized
--01	----	0---	----	Initializing
--10	----	0---	----	Initialization completed
--11	----	0---	----	Initialization failed

(- : optional)

Pan/Tilt Position (for reference)

	Parameter (position)
PAN	DE00 (-170 degree) to 2200 (+170 degree)
TILT	FC00 (-20 degree) to 1200 (+90 degree) (Image Flip: OFF) EE00 (-90 degree) to 0400 (+20 degree) (Image Flip: ON)

Other

Dimensions with ceiling bracket

Front

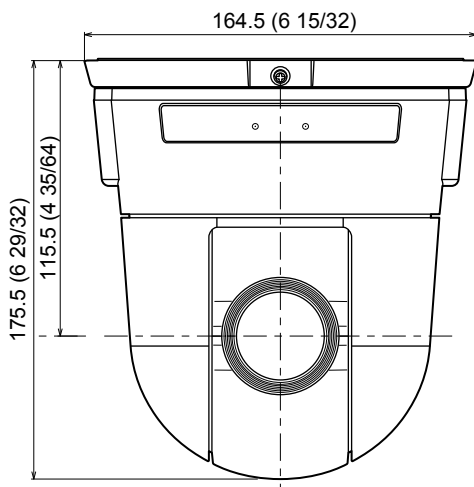

Side

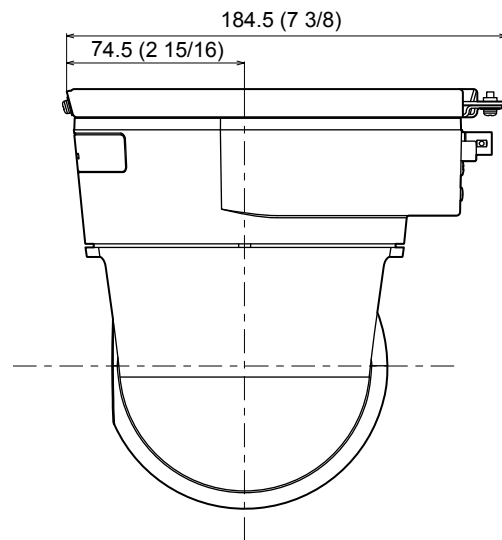

Ceiling bracket (B)

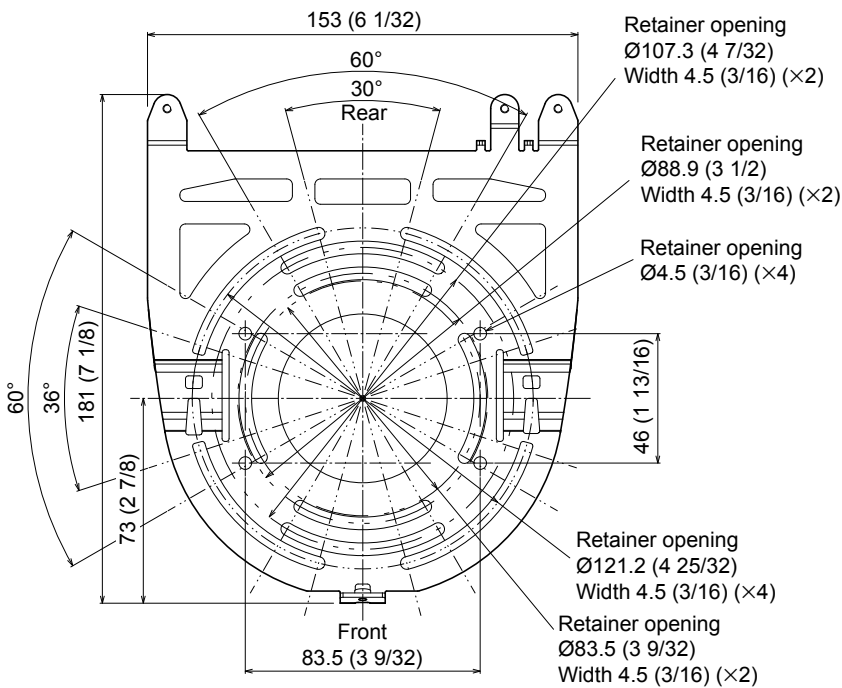

Unit: mm (inch)

Using the VISCA RS-422 connector pin assignments

The VISCA RS-422 connector pin assignments

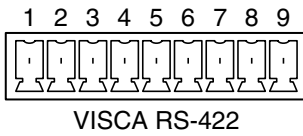

Pin No.	Function
1	TXD IN+
2	TXD IN-
3	RXD IN+
4	RXD IN-
5	GND
6	TXD OUT+
7	TXD OUT-
8	RXD OUT+
9	RXD OUT-

Using the VISCA RS-422 connector plug

- 1 Insert a wire (AWG Nos. 28 to 18) into the desired wire opening on the supplied VISCA RS-422 connector plug, and tighten the screw for that wire using a flat-head screwdriver.

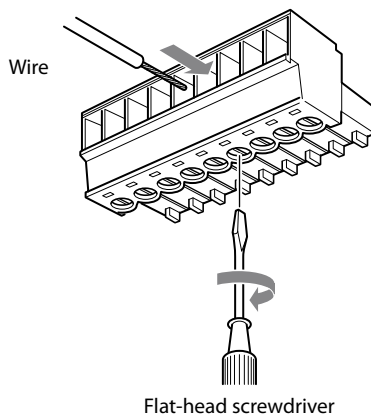

- 2 Insert the VISCA RS-422 connector plug into the VISCA RS-422 connector on the rear of the camera.

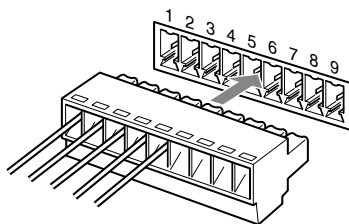

Note

In order to stabilize the voltage level of the signal, connect both ends to GND.

Wiring Diagram of VISCA RS-422 Connection

Third to Seventh SRG-300SE or SRG-301SE

VISCA RS-422 connector

9	RXD OUT -
8	RXD OUT +
7	TXD OUT -
6	TXD OUT +
5	GND
4	RXD IN -
3	RXD IN +
2	TXD IN -
1	TXD IN +

Second SRG-300SE or SRG-301SE

VISCA RS-422 connector

9	RXD OUT -
8	RXD OUT +
7	TXD OUT -
6	TXD OUT +
5	GND
4	RXD IN -
3	RXD IN +
2	TXD IN -
1	TXD IN +

First SRG-300SE camera or SRG-301SE

VISCA RS-422 connector

9	RXD OUT -
8	RXD OUT +
7	TXD OUT -
6	TXD OUT +
5	GND
4	RXD IN -
3	RXD IN +
2	TXD IN -
1	TXD IN +

RM-IP10 IP Remote Controller

VISCA RS-422 connector

1	NC
2	NC
3	NC
4	NC
5	GND
6	RXD IN -
7	RXD IN +
8	TXD IN -
9	TXD IN +

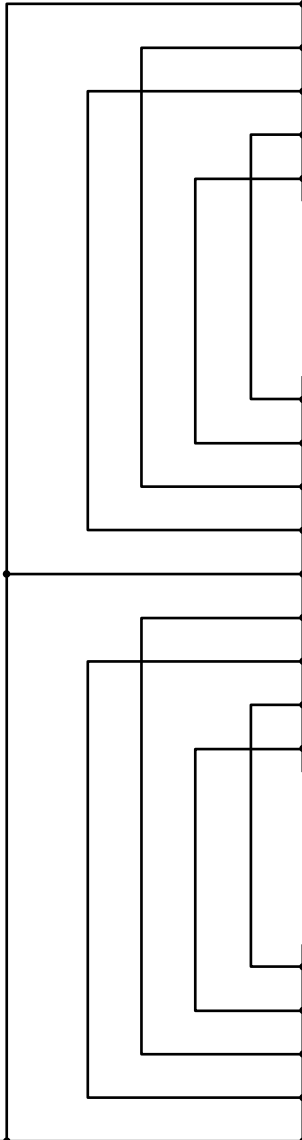

NC = No Connection